



### Revision History

Edition No.	Date of Revision	Revision Summary	Report Number
0	Jan. 04, 2021	Original Report	CTB210104006EX

## Table of Contents

1. TEST SUMMARY .....	
2. GENERAL INFORMATION .....	
2.1. Description of EUT .....	
2.2. Operating condition of EUT .....	
2.3. Test conditions .....	
2.4. Block diagram of EUT configuration .....	
3. FACILITIES .....	
3.1. Test Facility .....	
3.2. Test Instruments .....	
4. Measurement uncertainty .....	
5. Emission .....	
5.1. Insertion loss .....	
5.2. Disturbance voltage .....	
5.3. Radiated electromagnetic disturbances (30MHz to 1000MHz) .....	
5.4. Harmonic current emissions .....	
5.5. Voltage changes, voltage fluctuations and flicker .....	
6. Immunity .....	
6.1. Electrostatic discharge .....	
6.2. Radio-frequency electromagnetic field .....	
6.3. Power frequency magnetic fields .....	
6.4. Fast transients .....	
6.5. Injected currents (radio-frequency common mode) .....	
6.6. Surges .....	
7. Photographs of test setup .....	
8. Photographs of EUT .....	

## 1. TEST SUMMARY

EN 55015		
Clause	Requirement – Test case	Results
4.2	Insertion loss	N/A
4.3.1	Disturbance voltage at mains terminals ***	N/A
4.3.2	Disturbance voltage at load terminals	N/A
4.3.3	Disturbance voltage at control terminals	N/A
4.4.1	Radiated electromagnetic disturbances (9 kHz to 30 MHz) ***	Pass
4.4.2	Radiated electromagnetic disturbances (30 MHz to 1000 MHz) ***	Pass
Annex B	Independent method of measurement of radiated emission (CDNE)	N/A
EN 61000-3-2		
Clause	Requirement – Test case	Results
6.1	Control principle shall be allowed for the application according to the clause 6.1	N/A
6.2	Harmonic current emissions ***	N/A
EN 61000-3-3		
Clause	Requirement – Test case	Results
4	Voltage changes, voltage fluctuations and flicker ***	N/A
EN 61547		
Clause	Requirement – Test case	Results
5.2	Electrostatic discharge	Pass
5.3	Radio-frequency electromagnetic fields	Pass
5.4	Power frequency magnetic fields	pass
5.5	Fast transients	N/A
5.6	Injected currents (radio-frequency common mode)	N/A
5.7	Surges	N/A
5.8	Voltage dips and short interruptions	N/A
Supplementary information: --		

Remark: N/A is abbreviation for Not Applicable.

\*\*\* The test was carried out in all the test modes, only the worst data are list in report.

The test was carried out in all the test modes, only the worst data are list in report.

## 2. GENERAL INFORMATION

### 2.1. Description of EUT

Equipment	LED NIGHT LIGHT
Trade Mark	N/A
Model Name	TZ-NL01
Serial No.	TZ-NL02, TZ-NL03, TZ-NL05, TZ-NL06
Model Difference	All model's the function, software and electric circuit are the same, only with a product color and model named different. Test sample model: TZ-NL01
Normal Voltage	Battery DC3.7V, 500mAh and adapter DC 5V charge
Normal Testing Voltage	Battery DC3.7V, 500mAh and adapter DC 5V charge
Lamp technology used	<input type="checkbox"/> Fluorescent lamp <input type="checkbox"/> High pressure discharge lamp (HID) <input checked="" type="checkbox"/> Light emitting diode (LED/OLED) <input type="checkbox"/> Tungsten halogen lamp <input type="checkbox"/> Incandescent lamp <input type="checkbox"/> Others:

Note: The above EUT information is declared by manufacturer and for more detailed features description, please refer to the manufacturer's specifications or the User's Manual.

### 2.2. Operating condition of EUT

To investigate the maximum EMI emission characteristics generates from EUT, the test system was pre-scanning tested base on the consideration of following EUT operation mode or test configuration mode which possible have effect on EMI emission level. Each of these EUT operation mode(s) or test configuration mode(s) mentioned above was evaluated respectively

Pretest Mode	Description
Mode 1	Working

For Radiated Test	
Final Test Mode	Description
Mode 1	Working
Mode 2	charge

### 2.3. Test conditions

Temperature: 15-25°C

Relative Humidity: 30-60 %

Atmospheric pressure: 800hPa-1060hPa

### 2.4. Block diagram of EUT configuration

charge



working

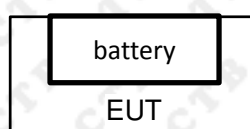

### 3. FACILITIES

#### 3.1. Test Facility

##### CTB-LAB

Floor 1&2, Building A, No. 26 of Xinghe Road, Xinqiao Street, Baoan District, Shenzhen China

#### 3.2. Test Instruments

Conducted Emission Measurement (Test software: EZ-EMC Ver. EMC-con3A1.1)

Item	Equipment	Manufacturer	Model No.	Serial No.	Calibrated until
1	AMN	ROHDE&SCHWARZ	ESH3-Z5	831551852	2021.10.30
2	Pulse limiter	ROHDE&SCHWARZ	ESH3Z2	357881052	2021.10.30
3	EMI TEST RECEIVER	ROHDE&SCHWARZ	ESCI	100428/003	2021.11.02
4	Coaxial cable	ZDECL	Z302S	18091904	2021.10.30
5	AAN	Schwarzbeck	NTFM8158	183	2021.11.07

Radiated Emission Measurement (Test software: EZ-EMC Ver. FA-03A2 RE)

Item	Equipment	Manufacturer	Model No.	Serial No.	Calibrated until
1	2m Triple-Loop Antenna	Daze	ZN30401	17014	2021.11.02
2	TRILOG Broadband Antenna	Schwarzbeck	VULB 9168	869	2021.11.02
4	Amplifier	HP	8447E	2945A02747	2021.11.01
5	EMI TEST RECEIVER	ROHDE&SCHWARZ	ESPI7	100362	2021.11.01
6	Coaxial cable	ETS	RFC-SNS-100-NMS-80 NI	/	2021.11.01
7	Coaxial cable	ETS	RFC-SNS-100-NMS-20 NI	/	2021.11.01
8	Coaxial cable	ETS	RFC-SNS-100-SMS-20 NI	/	2021.11.01
9	Coaxial cable	ETS	RFC-NNS-100-NMS-300 NI	/	2021.11.01

Harmonic Current & Voltage Fluctuation and Flicker (Test software: EZ-EMC Ver. FA-03A2 RE)

Item	Equipment	Manufacturer	Model No.	Serial No.	Calibrated until
1	Power Analyzer	Laplace Instruments	AC2000A	311363	2021.12.23
2	AC Power source	HTEC Instruments	HPF5010	633088	2021.12.23

Electrostatic Discharge Test

Item	Equipment	Manufacturer	Model No.	Serial No.	Calibrated until
1	ESD Simulator	TESTQ	NSG437	329	2021.10.30

Conducted RF Test

Item	Equipment	Manufacturer	Type No.	Serial No.	Calibrated until
1	Signal Generator	Agilent	N5182A	MY47420195	2021.10.30
2	Power Amplifier	AR	75A 250A	320289	2021.10.30
3	Attenuator	EM-Test	ATT6/75	320835	2021.10.30
4	CDN	EM-Test	CDN M2/M3	0208-01	2021.10.30
5	EM-Clamp	EM-Test	EM101	35762	2021.10.30

#### RF electromagnetic field Test

Item	Equipment	Manufacturer	Type No.	Serial No.	Calibrated until
1	Signal Generator	Agilent	N5182A	MY47420195	2021.10.30
2	Log-Bicon Antenna	Schwarzbeck	VULB9161	9128ES-128	2021.10.30
3	Power Amplifier	AR	150W1000M1	342526	2021.10.30
4	Microwave Horn Antenna	AR	AT4002A	322279	2021.10.30
5	Power Amplifier	AR	25S1G4A	321116	2021.10.30

#### Surge& Electrical Fast Transient/Burst Immunity Test

Item	Equipment	Manufacturer	Model No.	Serial No.	Calibrated until
1	Surge& Burst Generator	Lioncel	LSG-545CB	180602	2021.10.30
2	Capacitive coupling clamp	Lioncel	EFTC	18071801	2021.10.30

#### Power frequency magnetic field

Item	Equipment	Manufacturer	Model No.	Serial No.	Calibrated until
1	Magnetic field generator	Lioncel	PMF-801C-C	180701	2021.11.01

#### Voltage dips and interruptions Test

Item	Equipment	Manufacturer	Model No.	Serial No.	Calibrated until
1	Voltage dip simulator	Lioncel	VDS-1102	180902	2021.10.30

#### 4. Measurement uncertainty

The following table is for the measurement uncertainty, which is calculated as per the document CISPR 16-4.

This	Test	Parameters	Expanded Uncertainty ( $U_{Lab}$ )	Expanded Uncertainty ( $U_{Cispr}$ )
	Conducted Emission	Level Accuracy: 150kHz to 30MHz	$\pm 1.22$ dB	$\pm 3.6$ dB
	Radiated Emission	Level Accuracy: 30MHz to 1000 MHz	$\pm 3.67$ dB	$\pm 5.2$ dB
	Radiated Emission	Level Accuracy: Above 1000MHz	$\pm 4.79$ dB	N/A

uncertainty represents an expanded uncertainty expressed at approximately the 95% confidence level using a coverage factor of  $k=2$ .





## 5.2. Disturbance voltage

### 5.2.1. Limit

Disturbance voltage limits at mains terminals

Frequency range	Limits (dB $\mu$ V) <sup>a</sup>	
	Quasi-peak	Average
9KHz to 50KHz	110	--
50KHz to 150KHz	90 ~ 80 <sup>b</sup>	--
150KHz to 0.5MHz	66 ~ 56 <sup>b</sup>	56 ~ 46 <sup>b</sup>
0.5MHz to 5MHz	56 <sup>c</sup>	46 <sup>c</sup>
5.0MHz to 30MHz	60	50

<sup>a</sup> At the transition frequency, the lower limit applies.

<sup>b</sup> The limit decreases linearly with the logarithm of the frequency in the ranges 50 kHz to 150 kHz and 150 kHz to 0,5 MHz.

<sup>c</sup> For electrodeless lamps and luminaires, the limit in the frequency range of 2,51 MHz to 3,0 MHz is 73 dB( $\mu$ V)

Disturbance voltage limits at control terminals

Frequency range MHz	Limits (dB $\mu$ V) <sup>a</sup>	
	Quasi-peak	Average
0,15 to 0,5	80	70
0,5 to 30	74	64

<sup>a</sup> At the transition frequency, the lower limit applies.

Disturbance voltage limits at control terminals

Frequency range MHz	Limits (dB $\mu$ V) <sup>a</sup>	
	Quasi-peak	Average
0,15 to 0,5	80 to 74	74 to 64
0,5 to 30	74	64

NOTE 1 The limits decrease linearly with the logarithm of the frequency in the range 0,15 MHz to 0,5 MHz.

NOTE 2 The voltage disturbance limits are derived for use with an Asymmetric Artificial Network (AAN) which presents a common mode (asymmetric mode) impedance of 150  $\Omega$  to the control terminal.

## 5.2.2. Block diagram of test setup

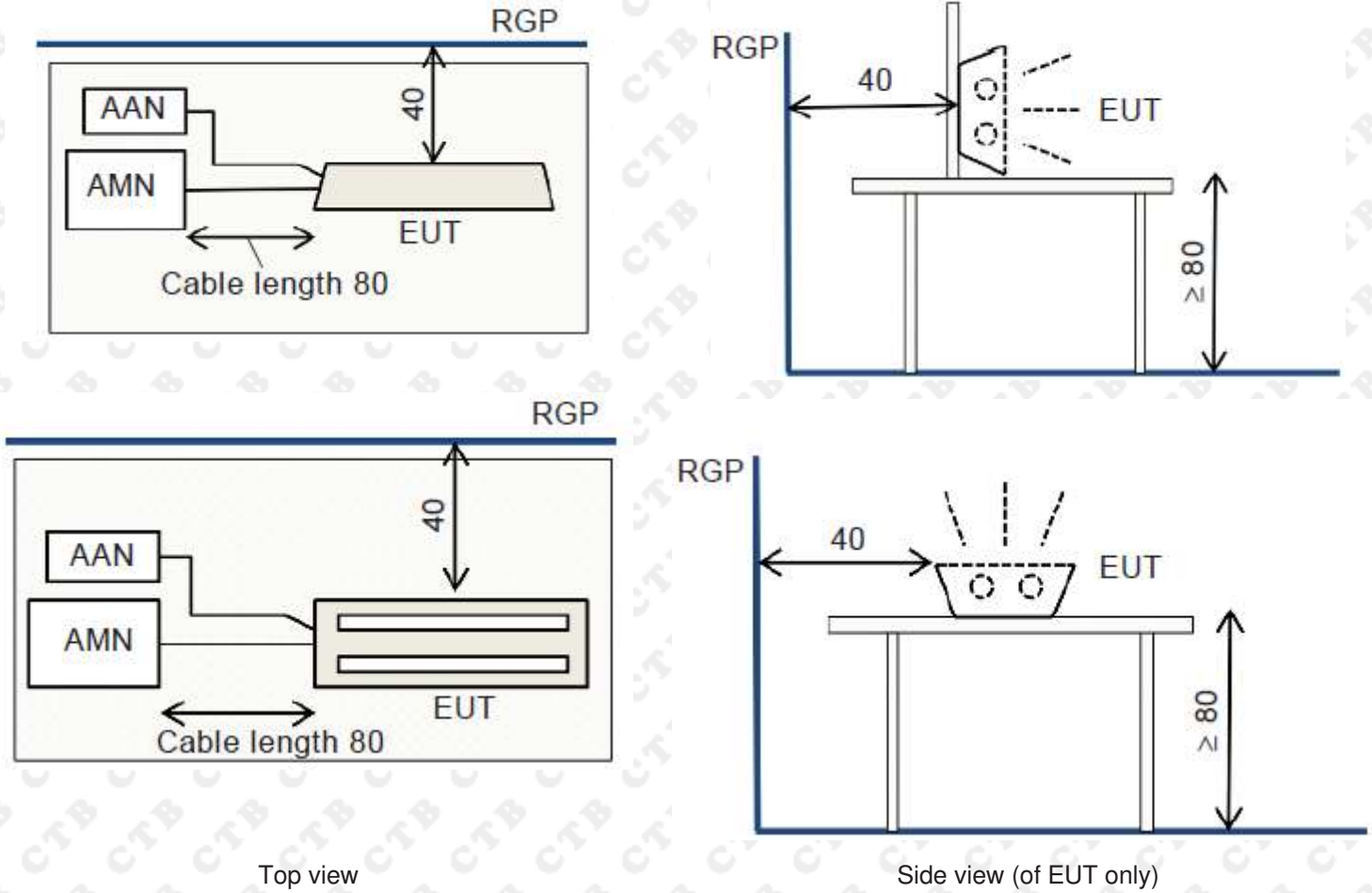

Top view

Side view (of EUT only)

## 5.2.3. Test procedure

Measurement was performed in shielded room, and instruments used were followed CISPR 16-2-1 clause 7. Detailed test procedure was following clause 7 of CISPR 16-2-1.

Frequency range 9kHz to 30MHz was checked and EMI receiver measurement bandwidth was set to 200Hz (9 to 150kHz), 9kHz (150kHz to 30MHz).

## 5.2.4. Test results

**N/A**

No adapters ,EUT not applicable to this test.

## Radiated electromagnetic disturbances (9KHz to 30MHz)

### 5.2.5. Limit

Radiated disturbance limits in the frequency range 9 kHz to 30 MHz

Frequency range MHz	Limits for loop diameter (dB $\mu$ A) <sup>a</sup>
	2m
9KHz to 70KHz	88
70KHz to 150KHz	88 ~ 58 <sup>b</sup>
150KHz to 3.0MHz	58 ~ 22 <sup>b</sup>
3.0MHz to 30MHz	22

<sup>a</sup> At the transition frequency, the lower limit applies.

<sup>b</sup> Decreasing linearly with the logarithm of the frequency. For electrodeless lamps and luminaires, the limit in the frequency range of 2,2MHz to 3,0MHz is 58dB(dB $\mu$ A) for 2m.

### 5.2.6. Block diagram of test setup

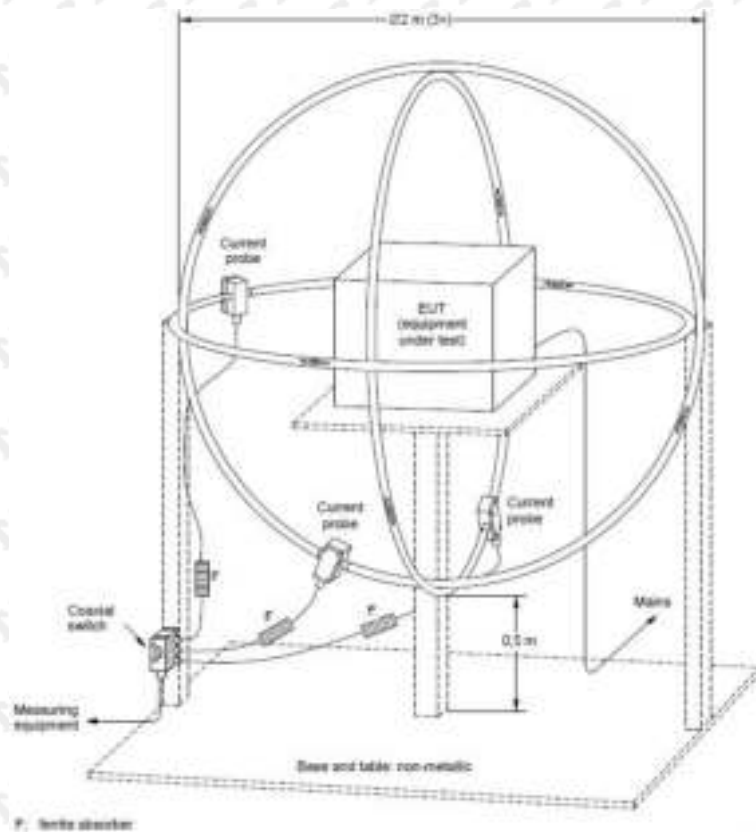

### 5.2.7. Test procedure

The EUT is placed on a wood table in the center of a loop antenna. The induced current in the loop antenna is measured by means of a current probe and the test receiver. Three axes of X Y Z are tested by coaxial switch.

The frequency range from 9KHz to 30MHz is investigated. The receiver is measured with the quasi-peak detector. For frequency band 9KHz to 150KHz, the bandwidth of the field strength meter (R&S test receiver ESCI) is set at 200Hz. For frequency band 150KHz to 30MHz, the bandwidth is set at 9KHz.

### 5.2.8. Test results

#### **PASS**

The peak value is too low against the limit, so the Test data is not record.

## 5.3. Radiated electromagnetic disturbances (30MHz to 1000MHz)

### 5.3.1. Limit

Frequency range MHz	Quai-peak limits (dB $\mu$ V/m) <sup>a</sup>
	3m <sup>b, c</sup>
30 to 230	40
230 to 1000	47

<sup>a</sup> At the transition frequency, the lower limit applies.

<sup>b</sup> Either of the two measurement distances and the associated limits can be applied to demonstrate compliance.

<sup>c</sup> Care should be taken when measuring a large EUT at 3 m and at frequencies near 30 MHz due to near field effects

### 5.3.2. Block diagram of test setup

#### Measurement distance

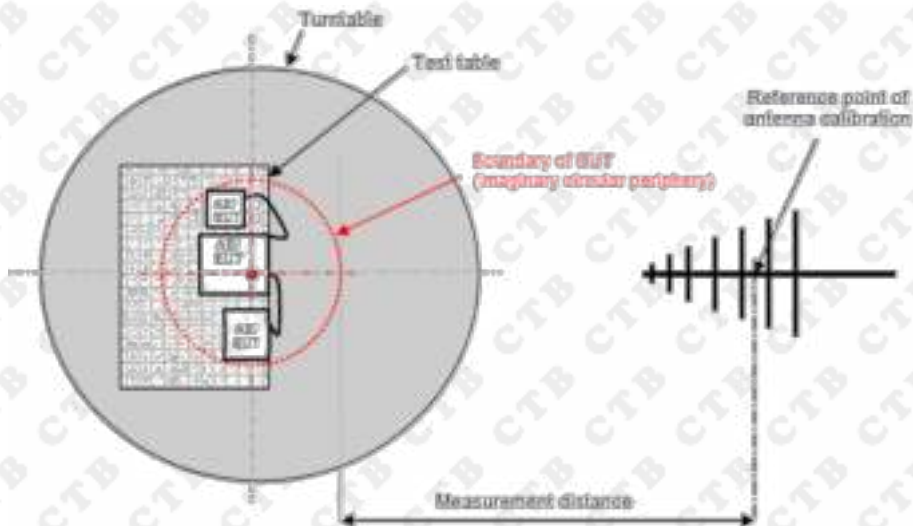

For table-top equipment

For floor standing equipment

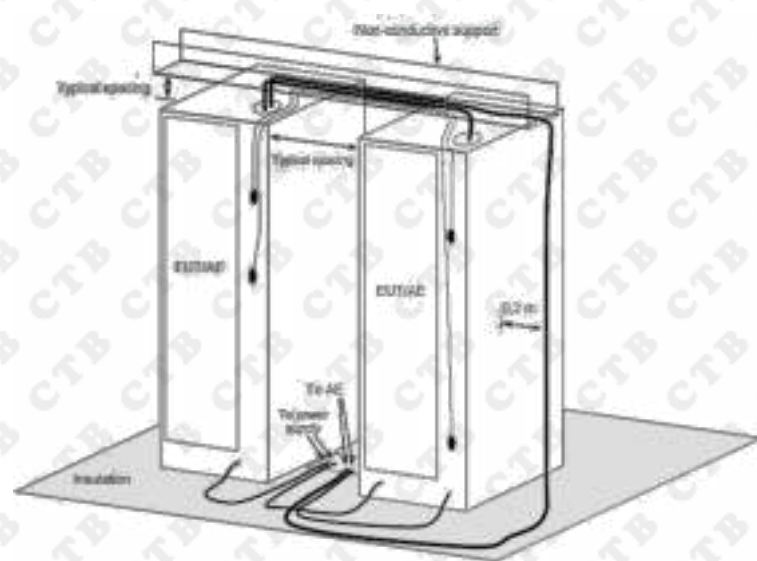
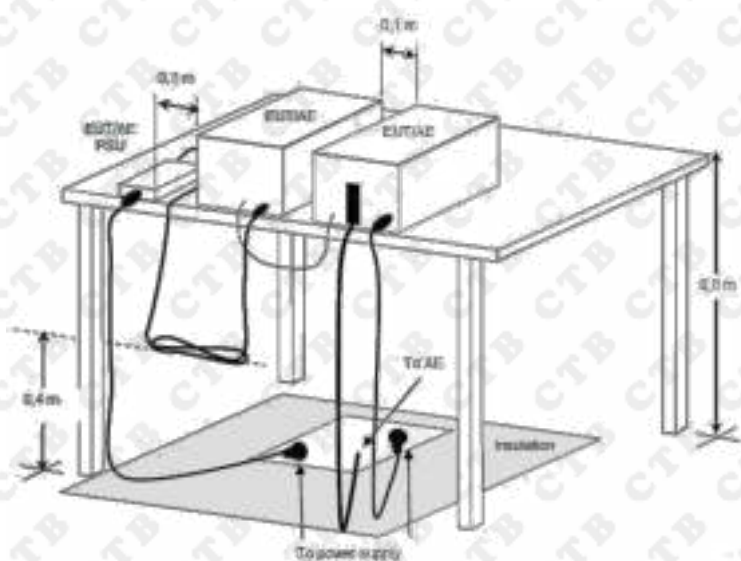

### 5.3.3. Test procedure

The measurement was performed in a semi-anechoic chamber.  
The distance from EUT to receiving antenna is 3 meters.  
Measurement was performed according to clause 7.3 of CISPR 16-2-3.

### 5.3.4. Test results

**PASS**

Please refer to the following page.

Polarization: H

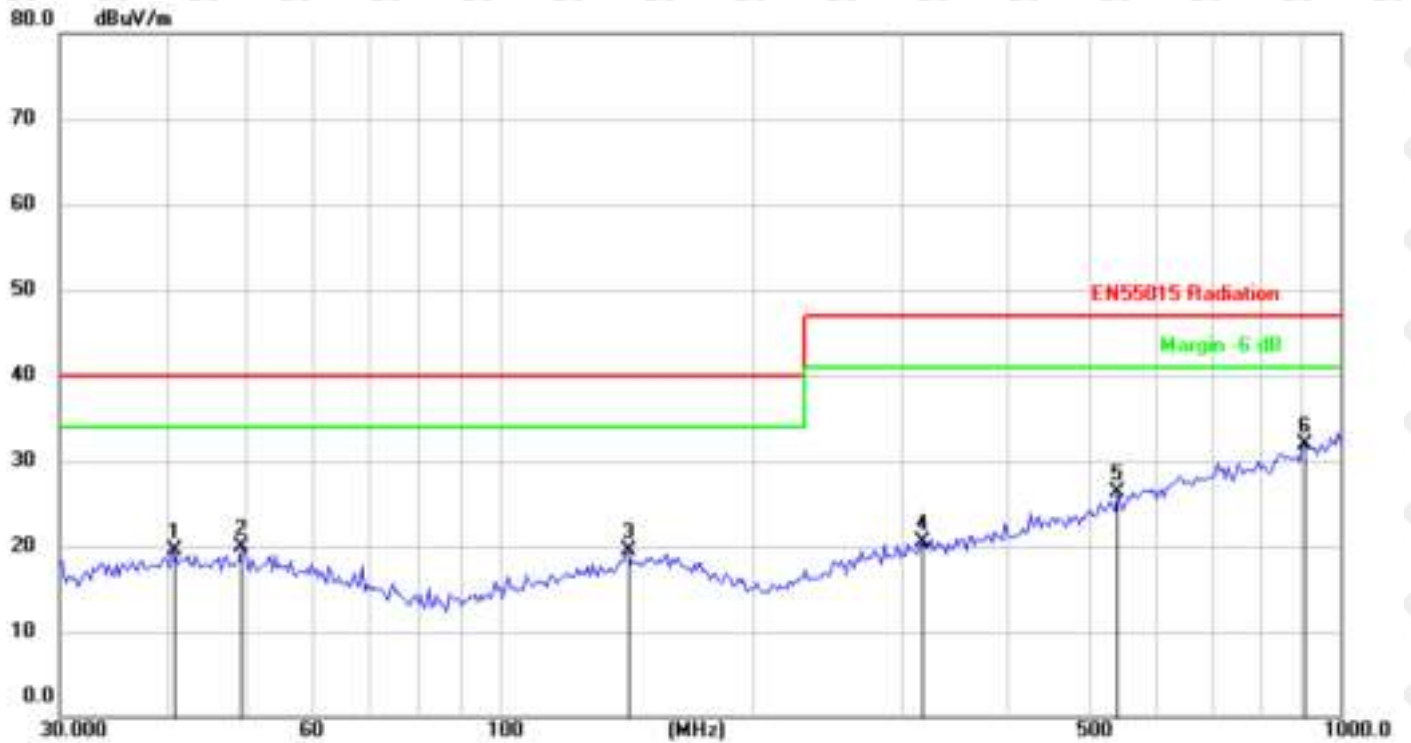

No.	Mk.	Freq. MHz	Reading Level dBuV	Correct Factor dB	Measure- ment dBuV/m	Limit dB/m	Margin dB	Antenna Height cm	Table Degree degree	Comment
1		40.8446	25.92	-6.39	19.53	40.00	-20.47	QP		
2		49.3594	26.50	-6.68	19.82	40.00	-20.18	QP		
3		142.3243	26.19	-6.65	19.54	40.00	-20.46	QP		
4		318.8170	25.86	-5.44	20.42	47.00	-26.58	QP		
5		543.2742	26.15	0.17	26.32	47.00	-20.68	QP		
6	*	906.4824	25.34	6.53	31.87	47.00	-15.13	QP		

Note: Result=Reading+Factor  
Over Limit=Result-Limit

Polarization: V

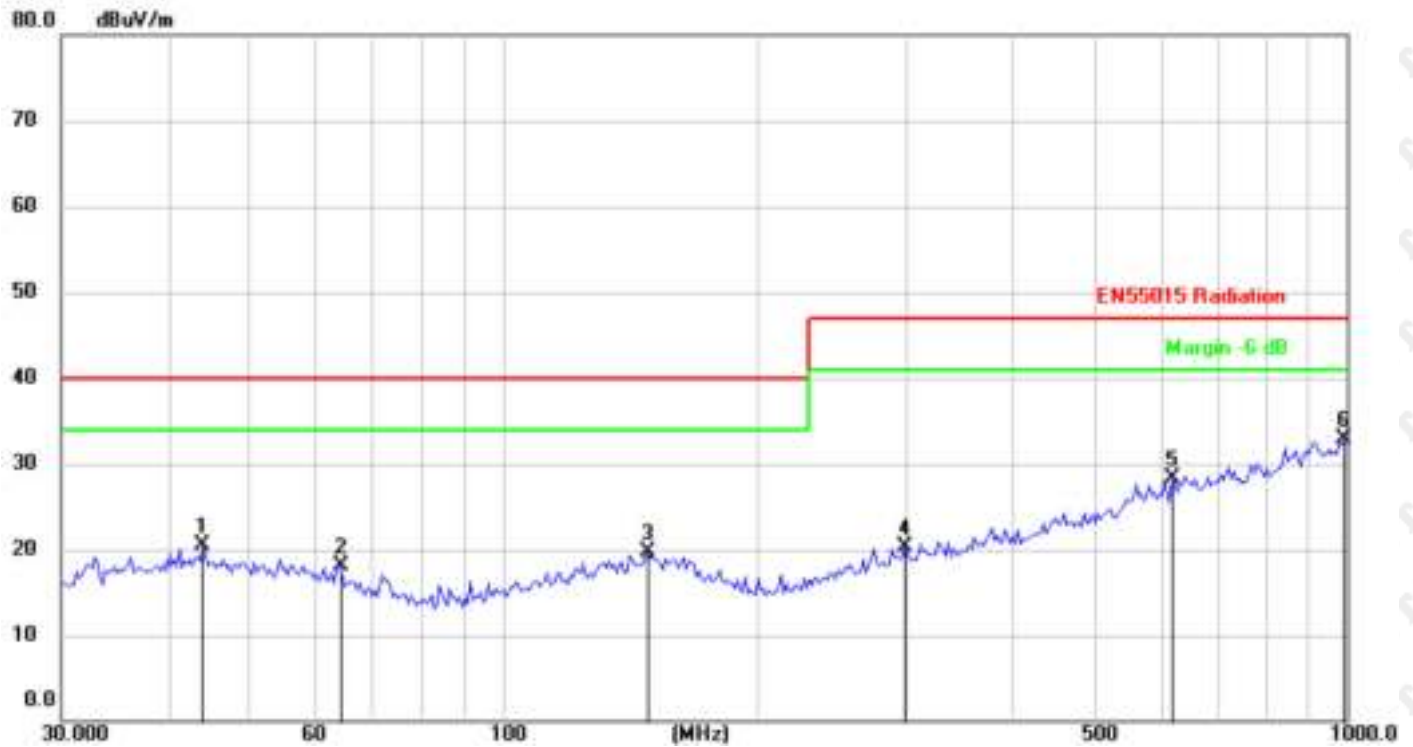

No.	Mk.	Freq. MHz	Reading Level dBuV	Correct Factor dB	Measure- ment dBuV/m	Limit dB/m	Margin dB	Antenna Height cm	Table Degree degree	Comment
1		44.1202	26.91	-6.50	20.41	40.00	-19.59	QP		
2		63.9828	26.42	-8.26	18.16	40.00	-21.84	QP		
3		148.4410	26.15	-6.49	19.66	40.00	-20.34	QP		
4		299.3158	26.30	-5.90	20.40	47.00	-26.60	QP		
5		620.7096	26.00	2.28	28.28	47.00	-18.72	QP		
6	*	993.0114	25.54	7.43	32.97	47.00	-14.03	QP		

Note: Result=Reading+Factor  
Over Limit=Result-Limit



## 5.4. Harmonic current emissions

### 5.4.1. Test Setup

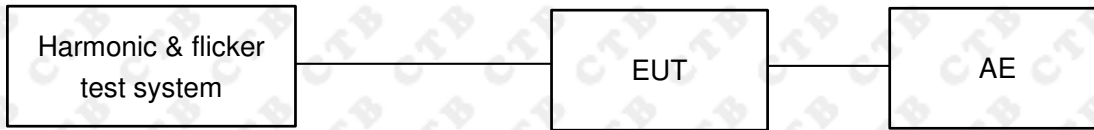

### 5.4.2. Test specifications

Basic Standard(s)	:	EN IEC 61000-3-2:2019
Measurement Equipment requirement	:	IEC 61000-4-7
Measured Harmonics	:	1 - 40
Equipment Class	:	<input type="checkbox"/> A <input checked="" type="checkbox"/> C
Limits	:	<input checked="" type="checkbox"/> Clause 7.1 Table 1 <input type="checkbox"/> Clause 7.3 Table 2

### 5.4.3. Test Procedure

Harmonics of the fundamental current were measured up to 40 order harmonics using a digital power meter with an analogue output and frequency analyzer which was integrated in the harmonic & flicker test system. The measurements were carried out under steady conditions.

- Active input power > 25 W
- Active input power  $\leq$  25 W

### 5.4.4. Test Result

N/a

No adapters ,EUT not applicable to this test.



## 5.5. Voltage changes, voltage fluctuations and flicker

### 5.5.1. Test Setup

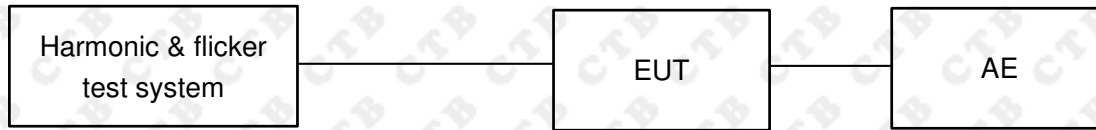

### 5.5.2. Test Procedure

Basic Standard(s)	: EN 61000-3-3:2013/A1:2019
Measurement Equipment requirement	: IEC 61000-4-15
Limits	: Clause 5

#### 5.4.2.1 Definition

Flicker: impression of unsteadiness of visual sensation induced by a lighting stimulus whose luminance or spectral distribution fluctuates with time.

$P_{st}$ : Short-term flicker indicator the flicker severity evaluated over a short period (in minutes);  $P_{st}=1$  is the conventional threshold of irritability

$P_{lt}$ : long-term flicker indicator; the flicker severity evaluated over a long period (a few hours) using successive  $P_{st}$  values.

dc: the relative steady-state voltage change

$d_{max}$ : the maximum relative voltage change

$d(t)$ : the value during a voltage change

#### 5.4.2.2 Test Procedure

The following limits apply

- " $P_{lt}$ " shall not exceed 0.65.
- " $P_{st}$ " shall not exceed 1.0.
- "dc" shall not exceed 3.3%.
- " $d(t)$ " shall not exceed 3.3% for more than 500ms.
- " $d_{max}$ " shall not exceed:
  - 4% without additional conditions,
  - 6% switched manually or automatically more than twice per day,
  - 7% attended whilst in use or switched automatically for no more than twice per day or attended while in use.
  - For manual switch,  $d_{max}$  is measured in accordance with Annex B of standard, average  $d_{max}$  is calculated from 24 times measurement.
  - The EUT is unlikely to produce significant voltage fluctuations or flicker by technical analysis and evaluation. So it is deemed to fulfil the requirements without testing.

### 5.5.3. Test Result

N/a

No adapters ,EUT not applicable to this test.

## 6. Immunity

### Performance criteria

#### Performance criterion A

The equipment shall continue to operate as intended without operator intervention. No degradation of performance or loss of function is allowed below a performance level specified by the manufacturer when the equipment is used as intended. The performance level may be replaced by a permissible loss of performance. If the minimum performance level or the permissible performance loss is not specified by the manufacturer, then either of these may be derived from the product description and documentation, and by what the user may reasonably expect from the equipment if used as intended.

#### Performance criterion B

After the test, the equipment shall continue to operate as intended without operator intervention. No degradation of performance or loss of function is allowed, after the application of the phenomena below a performance level specified by the manufacturer, when the equipment is used as intended. The performance level may be replaced by a permissible loss of performance. During the test, degradation of performance is allowed. However, no change of operating state or stored data is allowed to persist after the test. If the minimum performance level (or the permissible performance loss) is not specified by the manufacturer, then either of these may be derived from the product description and documentation, and by what the user may reasonably expect from the equipment if used as intended.

#### Performance criterion C

Loss of function is allowed, provided the function is self-recoverable, or can be restored by the operation of the controls by the user in accordance with the manufacturer's instructions. Functions, and/or information stored in non-volatile memory, or protected by a battery backup, shall not be lost.

## 6.1. Electrostatic discharge

### 6.1.1. Test Levels and Performance Criterion

Characteristics	Test levels
Air discharge	±8 kV
Contact discharge	±4 kV

Performance criterion: **B**

### 6.1.2. Test setup

For table-top equipment

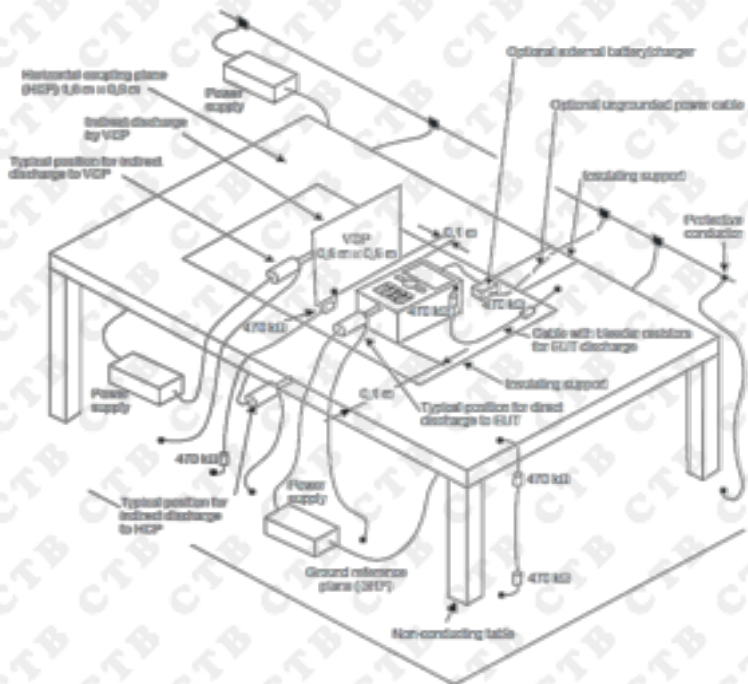

For floor standing equipment

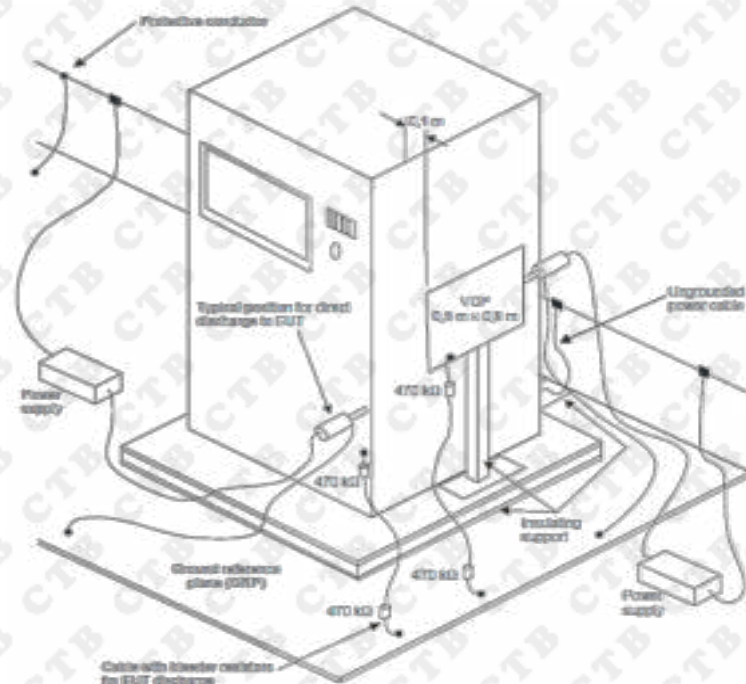

### 6.1.3. Test Procedure

Measurement was performed in shielded room.

Measurement procedure was applied according to EN 61000-4-2 clause 8.

The test method and equipment were specified by EN 61000-4-2.

### 6.1.4. Test Result

**PASS**

Please refer to the following page.

No.	Location of discharge	Polarity	Discharge	Number of discharges	Test level kV	Result
1	HCP	P&N	C	25	4	PASS
2	VCP	P&N	C	25	4	PASS
3	Points on conductive surface	P&N	C	25	4	PASS
4	Points on non-conductive surface	P&N	A	10	8	PASS

HCP = Horizontal coupling plate    VCP = Vertical coupling plate    N = Negative    P = Positive  
A = Air discharge    C = Contact discharge

## 6.2. Radio-frequency electromagnetic field

### 6.2.1. Test Levels and Performance Criterion

Characteristics	Test levels
Frequency range	80 MHz to 1 000 MHz
Test level	3 V/m (unmodulated)
Modulation	1 kHz, 80 % AM, sine wave

Performance criterion: **A**

### 6.2.2. Test setup

For table-top equipment

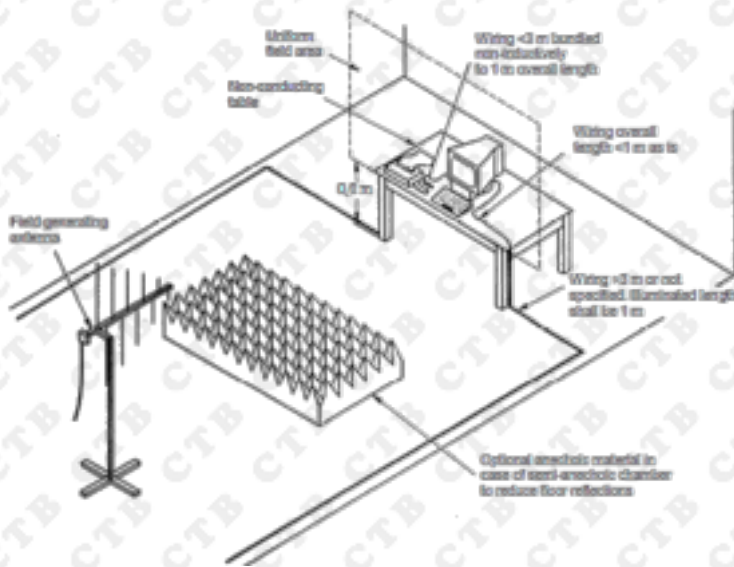

For floor standing equipment

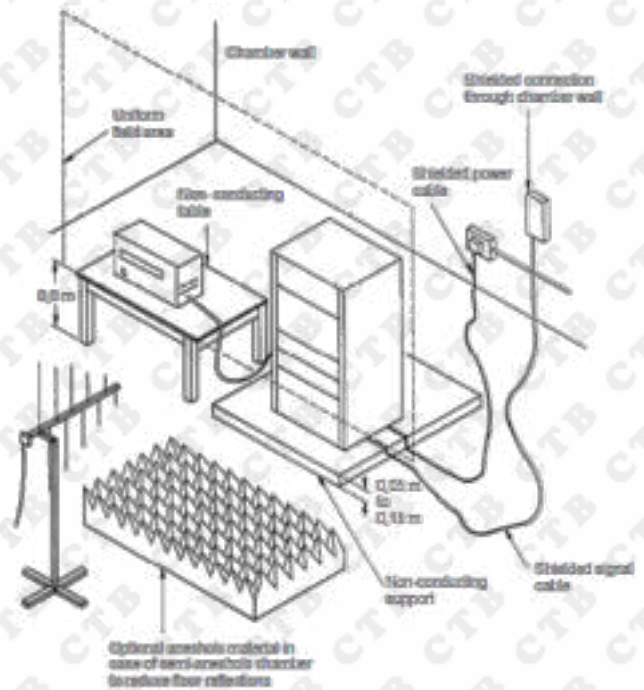

### 6.2.3. Test Procedure

Measurement was performed in full-anechoic chamber.

Measurement procedure was applied according to EN 61000-4-3 clause 8.

The test method and equipment was specified by EN 61000-4-3.

### 6.2.4. Test Result

**PASS**

Enclosure	Horizontal	Vertical
Front	PASS	PASS
Right Side	PASS	PASS
Left Side	PASS	PASS
Rear	PASS	PASS

### 6.3. Power frequency magnetic fields

#### 6.3.1. Test Levels and Performance Criterion

Characteristics	Test levels
Field frequency	50/60 Hz
Test level	3 A/m

Performance criterion: **A**

#### 6.3.2. Test setup

For table-top equipment

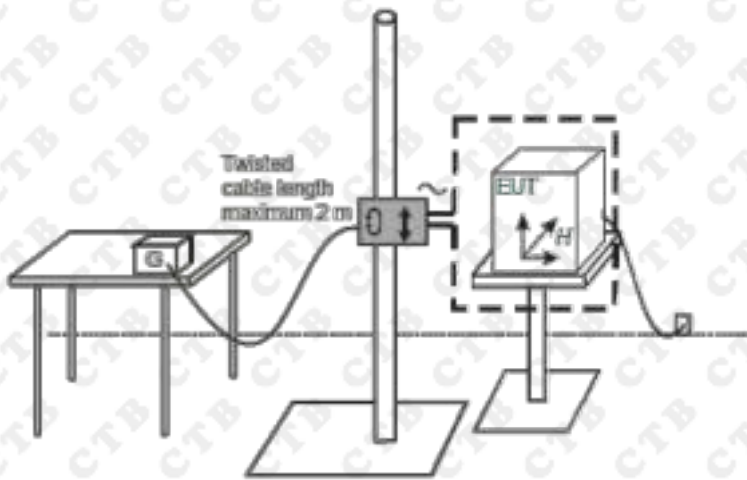

For floor standing equipment

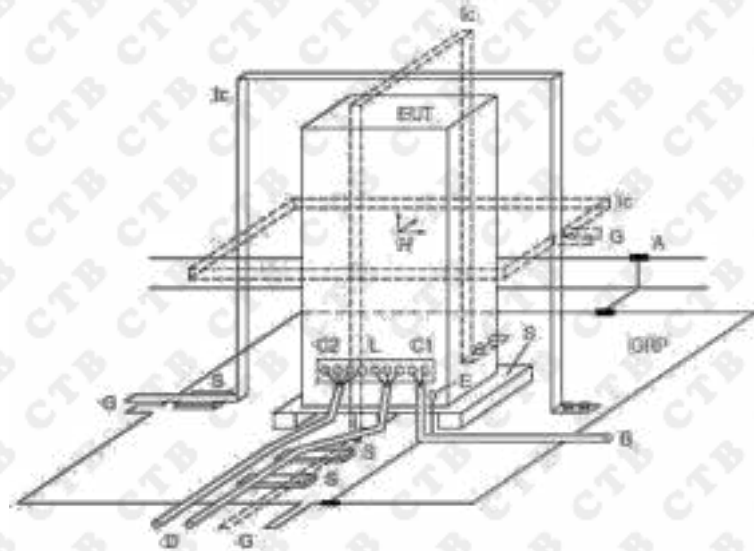

#### 6.3.3. Test Procedure

Measurement was performed in shielded room.

Measurement procedure was applied according to EN 61000-4-8 clause 8.

The test method and equipment was specified by EN 61000-4-8.

#### 6.3.4. Test Result

**PASS**

Test frequency	Test Level (A/m)	Test time [s]	Axis	Result
<input checked="" type="checkbox"/> 50Hz <input type="checkbox"/> 60Hz	3	300	X	Pass
<input checked="" type="checkbox"/> 50Hz <input type="checkbox"/> 60Hz	3	300	Y	Pass
<input checked="" type="checkbox"/> 50Hz <input type="checkbox"/> 60Hz	3	300	Z	Pass

## 6.4. Fast transients

### 6.4.1. Test Levels and Performance Criterion

Test levels at ports for signal and control lines

Characteristics	Test levels
Test level	$\pm 0.5$ kV (peak)
Rise time/hold time	5/50 ns
Repetition frequency	5 kHz
NOTE 1 Only applicable to ports interfacing with cables whose total length, according to the manufacturer's specification, may exceed 3 m.	
NOTE 2 Change of state commands are not applied during the test.	

Test levels at input and output d.c. power ports

Characteristics	Test levels
Test level	$\pm 0.5$ kV (peak)
Rise time/hold time	5/50 ns
Repetition frequency	5 kHz
NOTE Not applicable to equipment not connected to the mains while in use.	

Test levels at input and output a.c. power ports

Characteristics	Test levels
Test level	$\pm 1$ kV (peak)
Rise time/hold time	5/50 ns
Repetition frequency	5 kHz

Performance criterion: **B**

### 6.4.2. Test setup

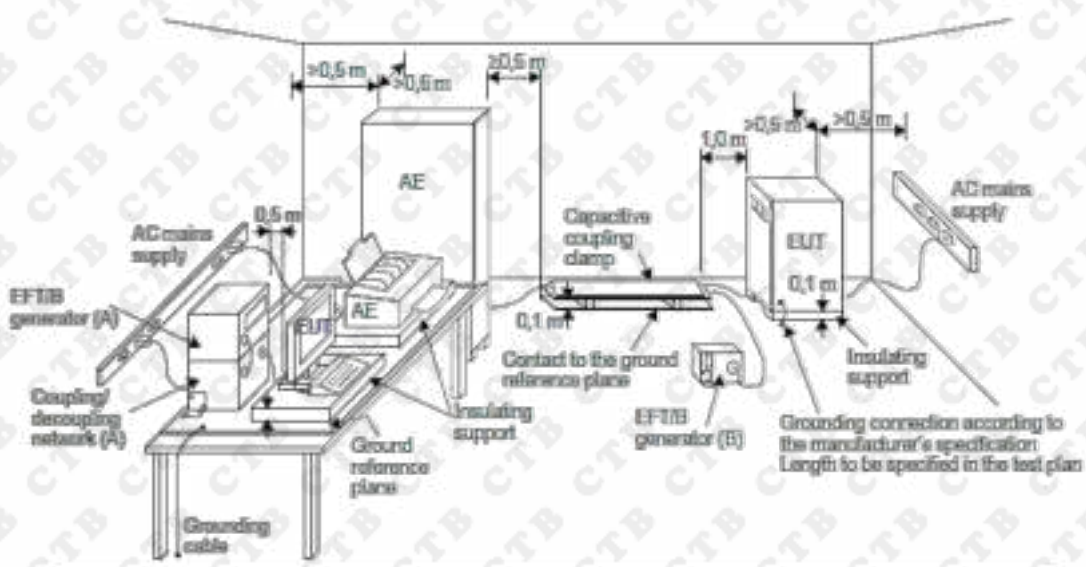



### 6.4.3. Test Procedure

Measurement was performed in shielded room.

Measurement procedure was applied according to EN 61000-4-4 clause 8.

The test method and equipment was specified by EN 61000-4-4.

### 6.4.4. Test Result

**N/A**

No adapters ,EUT not applicable to this test.

Location	Level (kV)	Polarity (P/N)	Result
AC power ports	1	P/N	N/A
DC power ports	0,5	P/N	N/A
Signal and control lines	0,5	P/N	N/A

## 6.5. Injected currents (radio-frequency common mode)

### 6.5.1. Test Levels and Performance Criterion

#### Test levels at ports for signal and control lines

Characteristics	Test levels
Frequency range	0.15 MHz to 80 MHz
Test level	3 V r.m.s. (unmodulated)
Modulation	1 kHz, 80 % AM, sine wave
Source impedance	150 Ω
NOTE Only applicable to ports interfacing with cables whose total length, according to the manufacturer's specification, may exceed 3 m.	

#### Test levels at input and output d.c. power ports

Characteristics	Test levels
Frequency range	0.15 MHz to 80 MHz
Test level	3 V r.m.s. (unmodulated)
Modulation	1 kHz, 80 % AM, sine wave
Source impedance	150 Ω
NOTE Only applicable to equipment that is connected to the mains while in use.	

#### Test levels at input and output a.c. power ports

Characteristics	Test levels
Frequency range	0.15 MHz to 80 MHz
Test level	3 V r.m.s. (unmodulated)
Modulation	1 kHz, 80 % AM, sine wave
Source impedance	150 Ω
NOTE Only applicable to ports interfacing with cables whose total length, according to the manufacturer's specification, may exceed 3 m.	

Performance criterion: **A**

## 6.5.2. Test setup

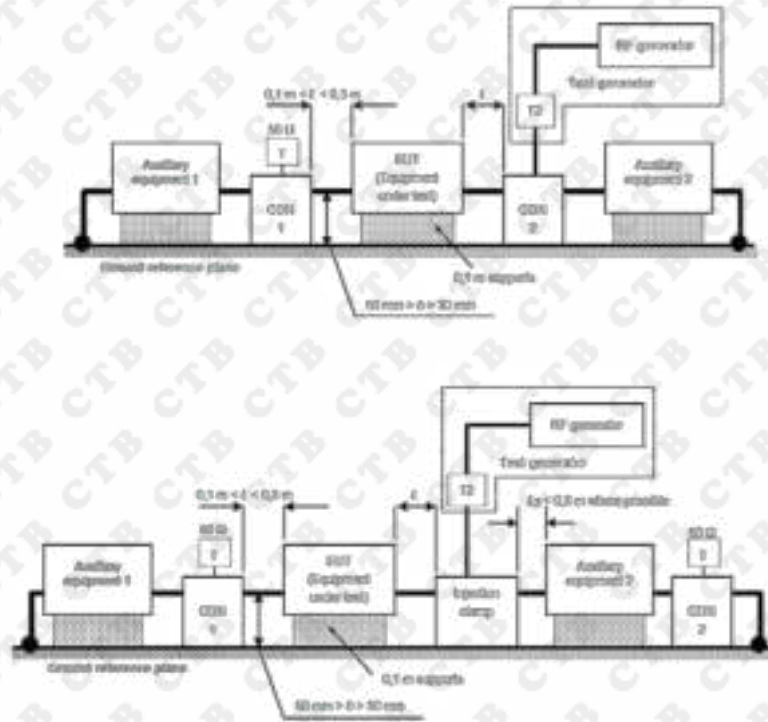

## 6.5.3. Test Procedure

Measurement procedure was applied according to EN 61000-4-6 clause 8. The test method and equipment was specified by EN 61000-4-6.

## 6.5.4. Test Result

**N/A**

No adapters ,EUT not applicable to this test.

Injected point	Frequency (MHz)	Level (e.m.f)	Modulation	Result
AC power ports	0.15 to 80	3V	80%, 1 kHz, AM	N/A
DC power ports	0.15 to 80	3V	80%, 1 kHz, AM	N/A
Signal and control lines	0.15 to 80	3V	80%, 1 kHz, AM	N/A

## 6.6. Surges

### 6.6.1. Test Levels and Performance Criterion

Characteristics	Test levels			
	Device			
	Self-ballasted lamps and semi-luminaires	Luminaires and independent auxiliaries		
		Input power		
		≤25 W	>25 W	
Wave-shape data	1.2/50 μs	1.2/50 μs	1.2/50 μs	
Test levels				
	line to line	±0.5 kV	±1.0 kV	
	line to ground	±1.0 kV	±2.0 kV	

NOTE In addition to the specified test level, all lower test levels as detailed in IEC 61000-4-5 should also be satisfied.

Performance criterion: **B**

### 6.6.2. Test setup

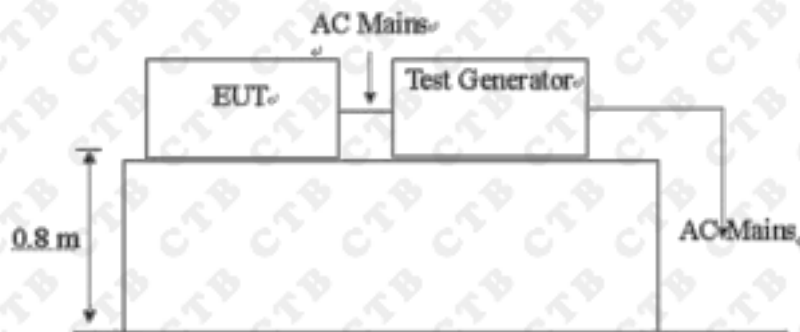

### 6.6.3. Test Procedure

Measurement was performed in shielded room.

Measurement procedure was applied according to EN 61000-4-5 clause 8.

The test method and equipment was specified by EN 61000-4-5.

### 6.6.4. Test Result

N/A

No adapters ,EUT not applicable to this test.

Location	Level(kV)	Polarity(P/N)	Result
Luminaires and independent auxiliaries >25 W (line to line)	1	P/N	N/A
Luminaires and independent auxiliaries >25 W (line to ground)	2	P/N	N/A
Luminaires and independent auxiliaries ≤25 W (line to line)	0,5	P/N	N/A
Luminaires and independent auxiliaries ≤25 W (line to ground)	1.0	P/N	N/A
Self-ballasted lamps and semi-luminaires (line to line)	0,5	P/N	N/A
Self-ballasted lamps and semi-luminaires (line to ground)	1.0	P/N	N/A

## Voltage dips and Short interruptions

### 6.6.5. Test Levels and Performance Criterion

#### Voltage dips – Test levels at input a.c. power ports

Characteristics	Test levels
Test voltage level	70 %
Number of periods	10

#### Voltage short interruptions – Test levels at input a.c. power ports

Characteristics	Test levels
Test voltage level	0 %
Number of periods	0.5

Performance criterion: C & B

### 6.6.6. Test setup

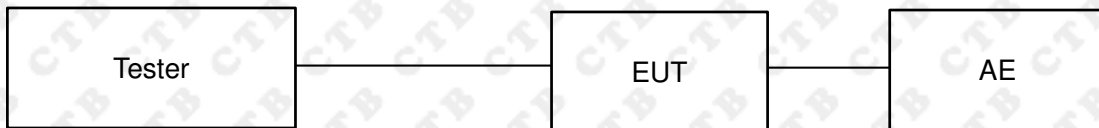

### 6.6.7. Test Procedure

Measurement was performed in shielded room.

Measurement procedure was applied according to EN 61000-4-11 clause 8.

The test method and equipment was specified by EN 61000-4-11.

### 6.6.8. Test Result

**N/A**

No adapters ,EUT not applicable to this test.

Test level %U <sub>T</sub>	Voltage dips & short interruptions %U <sub>T</sub>	Duration [Cycles]	Result
70	30	10	N/A
0	100	0.5	N/A

Remark: U<sub>T</sub> is the rated voltage for the equipment.

## 7. Photographs of test setup

Photograph of test setup for Radiated electromagnetic disturbances (30 MHz to 1000MHz)



**8. Photographs of EUT**



Photographs of EUT

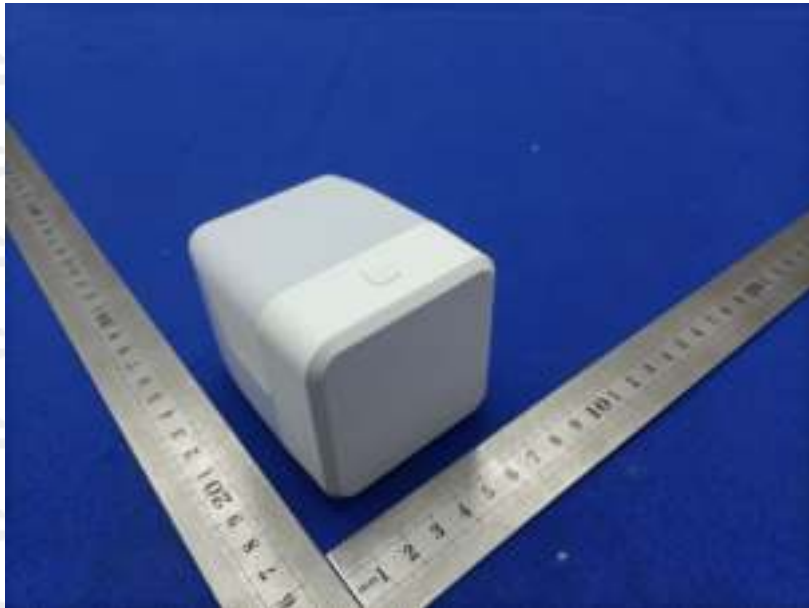
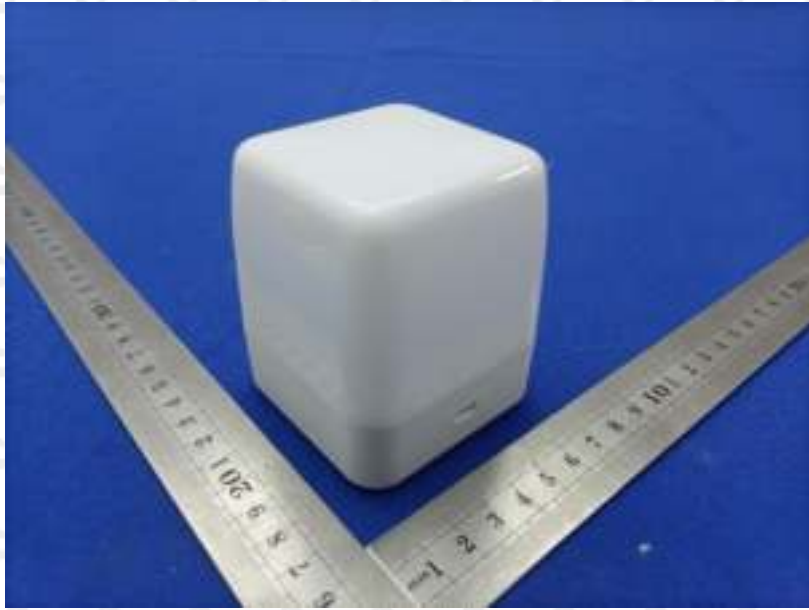



Photographs of EUT

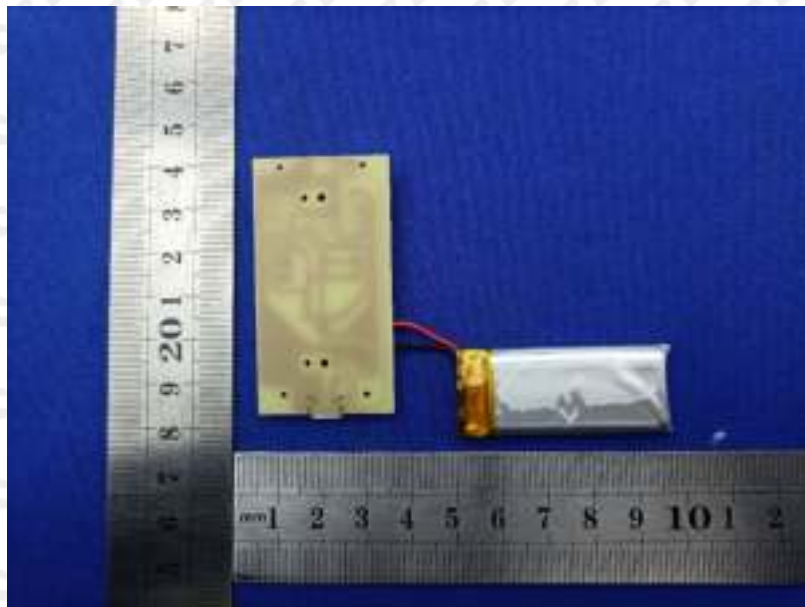

\*\*\*End of report\*\*\*