

TCORX
FITNESS IN MOTION

INSTRUCTION



MSX70



Rev : 00

Ed : 02/17



Contents

Components - Parts	3-4
Components – Fixings	5
Assembly Instructions	6-21
Home Gym Exercise	22-24
Guide Exercising	25-28
Information	25
Starting to exercise	25
Muscle chart	26
Warming up and cooling down	27-28
Exercises	
Care and Maintenance	29
Free area and training area	30
Resistance chart	31
Exploded Parts List	32-34
Guarantee	35

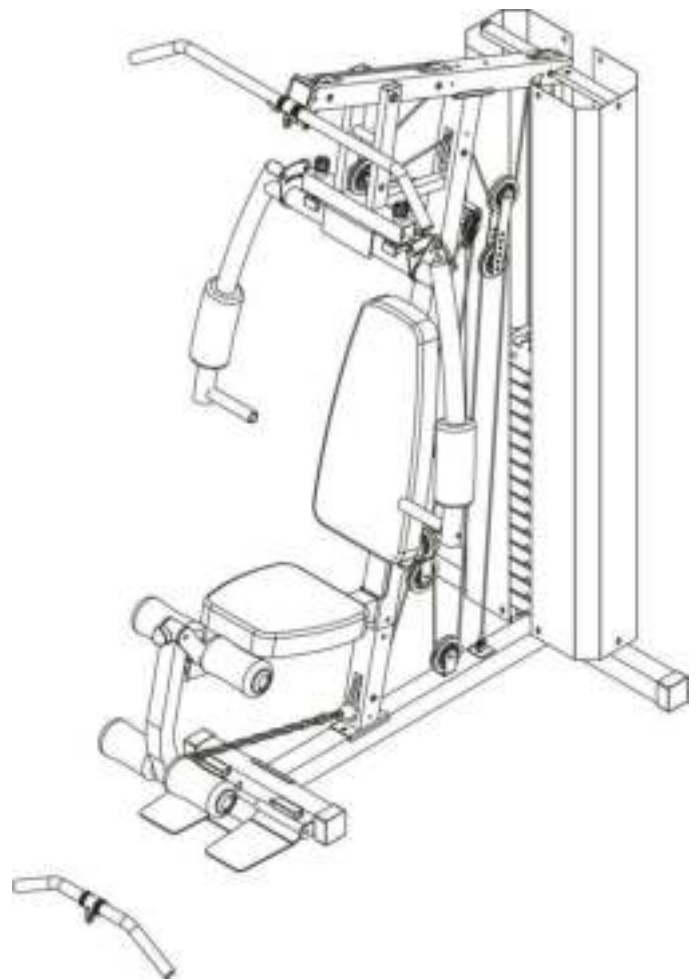

Components - Parts

Please check you have all parts listed below

Note: Some of the smaller components may be pre-fitted to larger components. Please check carefully before contacting Argos regarding any missing components.

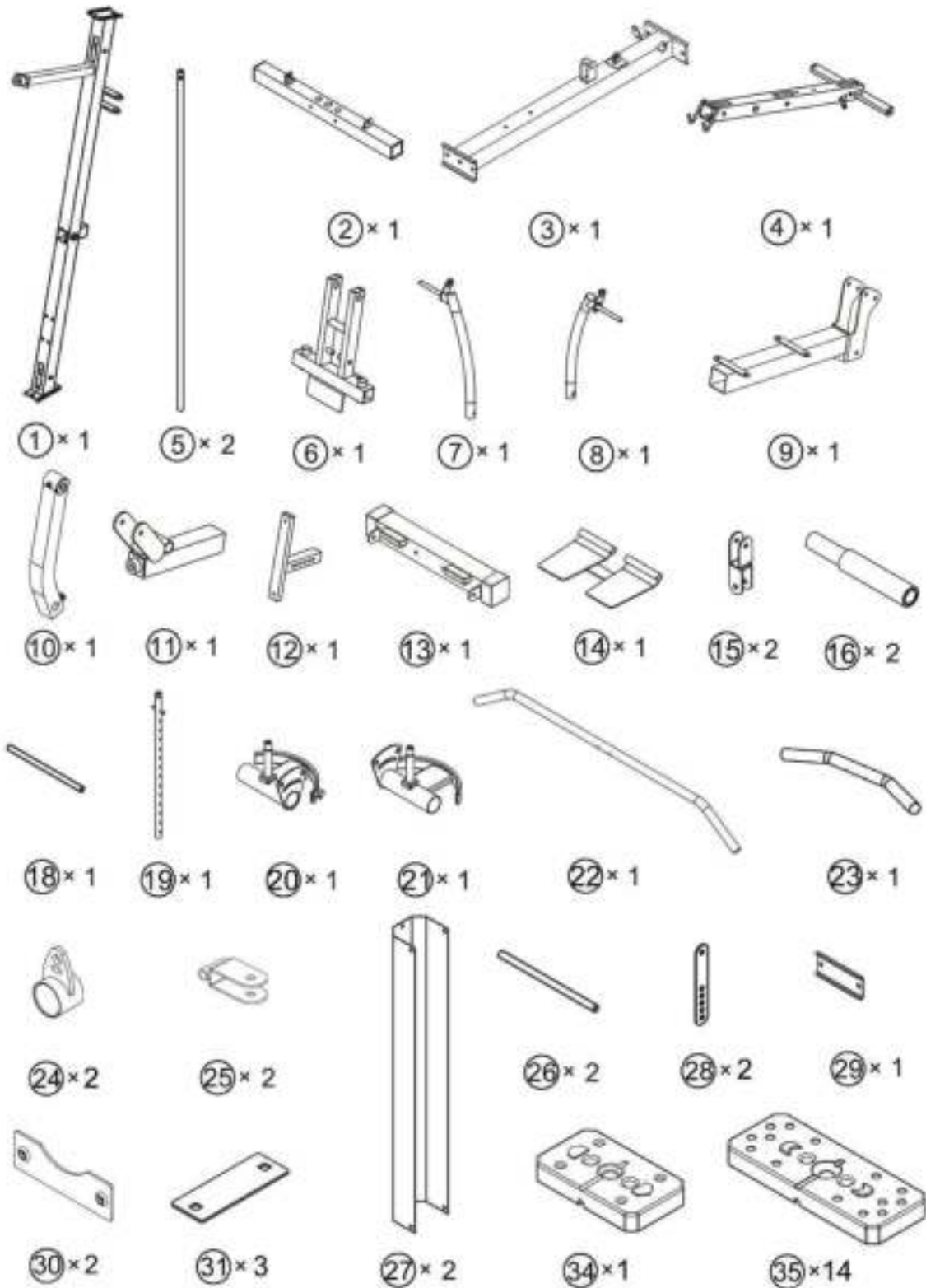

Components - Parts

Please check you have all parts listed below

















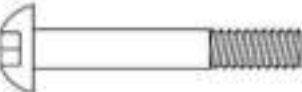
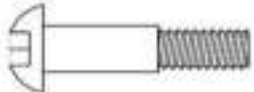
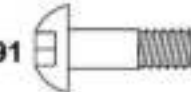

Note: Some of the smaller components may be pre-fitted to larger components. Please check carefully before contacting Argos regarding any missing components.

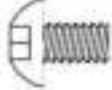
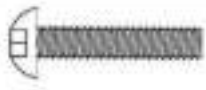
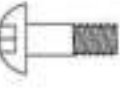

Components - Fixings

Please check you have all fixings listed below

Note: Some of the smaller components may be pre-fitted to the larger components. Please check carefully before contacting Argos regarding any missing components. Please prepare an adjustable spanner by yourself when you are intend to assemble this machine.

 <p>79 Ø16×M10×169mm Axle ×1</p>		 <p>80 Ø16×M10×57mm Axle ×1</p>
 <p>81 7# Clip Hook × 4</p>	 <p>82 15 Joint Chain × 1</p>	 <p>83 10 Joint Chain ×1</p>
 <p>85 M10×85mm Carriage Bolt × 8</p>	 <p>86 M10×150mm Allen Bolt × 1</p>	
 <p>87 M10×85mm Allen Bolt × 5</p>	 <p>88 Ø10×100×35 Select Pin × 1</p>	
 <p>89 M10×65mm Allen Bolt × 2</p>	 <p>90 M10×50mm Allen Bolt ×7</p>	 <p>91 M10×30mm Allen Bolt ×1</p>
 <p>92 M10×20mm Allen Bolt ×12</p>	 <p>93 M10×16mm Allen Bolt × 14</p>	 <p>95 M8×40mm Allen Bolt × 2</p>
 <p>96 M8×22mm Allen Bolt × 2</p>	 <p>97 M8×18mm Allen Bolt × 4</p>	 <p>99 M6×16mm phillips screw × 2</p>
 <p>100 Ø10mm Washer × 68</p>	 <p>101 Ø8mm Washer × 10</p>	 <p>102 M10 Aircraft Nut × 30</p>
 <p>103 M8 Aircraft Nut × 2</p>	 <p>61 Ø30×Ø10.5 Washer × 2</p>	 <p>Allen keys 5,6,mm</p>

Ruler - Use this ruler to help correctly identify the hardware



Assembly instructions

Step 1

(A). Insert the 2 pcs guide rods (5) into the holes of the rear stabilizer (2) separately . and Secure them with 2 pcs $\text{\O}10\text{mm}$ Washers (100) and 2 pcs M10 x 20mm Allen Bolts (92) . Slide the 2 pcs rubber bumpers (65) along the guide rods from the top to the bottom.

(B). Attach the main base frame (3) to the rear stabilizer(2), Secure them with 2 pcs M10x85 carriage bolts(85), one pc bracket(29), 2 pcs $\text{\O}10$ washers(100) and 2 pcs M10 Aircraft nuts(102).

(C). Attach the front stabilizer(13) to the main base frame(3), Secure them with one pc bracket(31), 2 pcs M10x85 carriage bolts(85), 2 pcs $\text{\O}10$ washer(100) and 2 pcs M10 Aircraft nut(102).

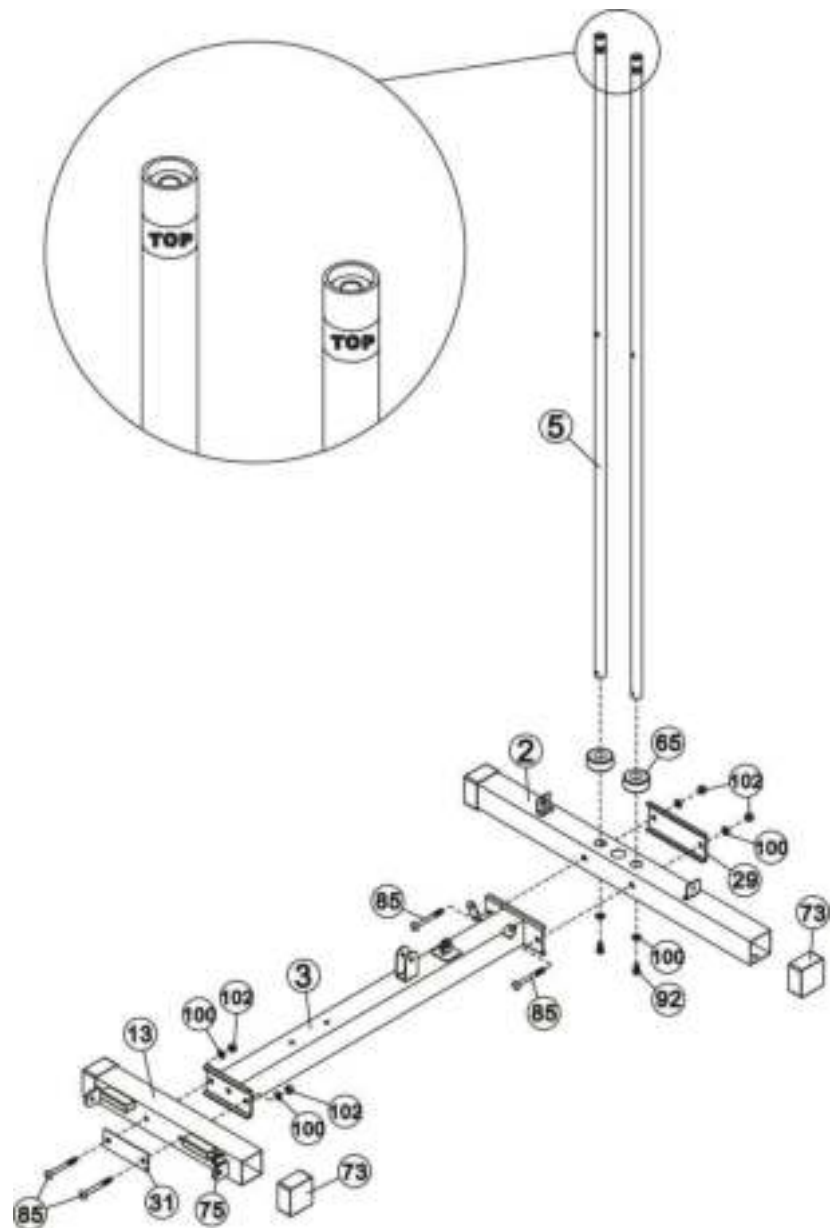

Assembly instructions

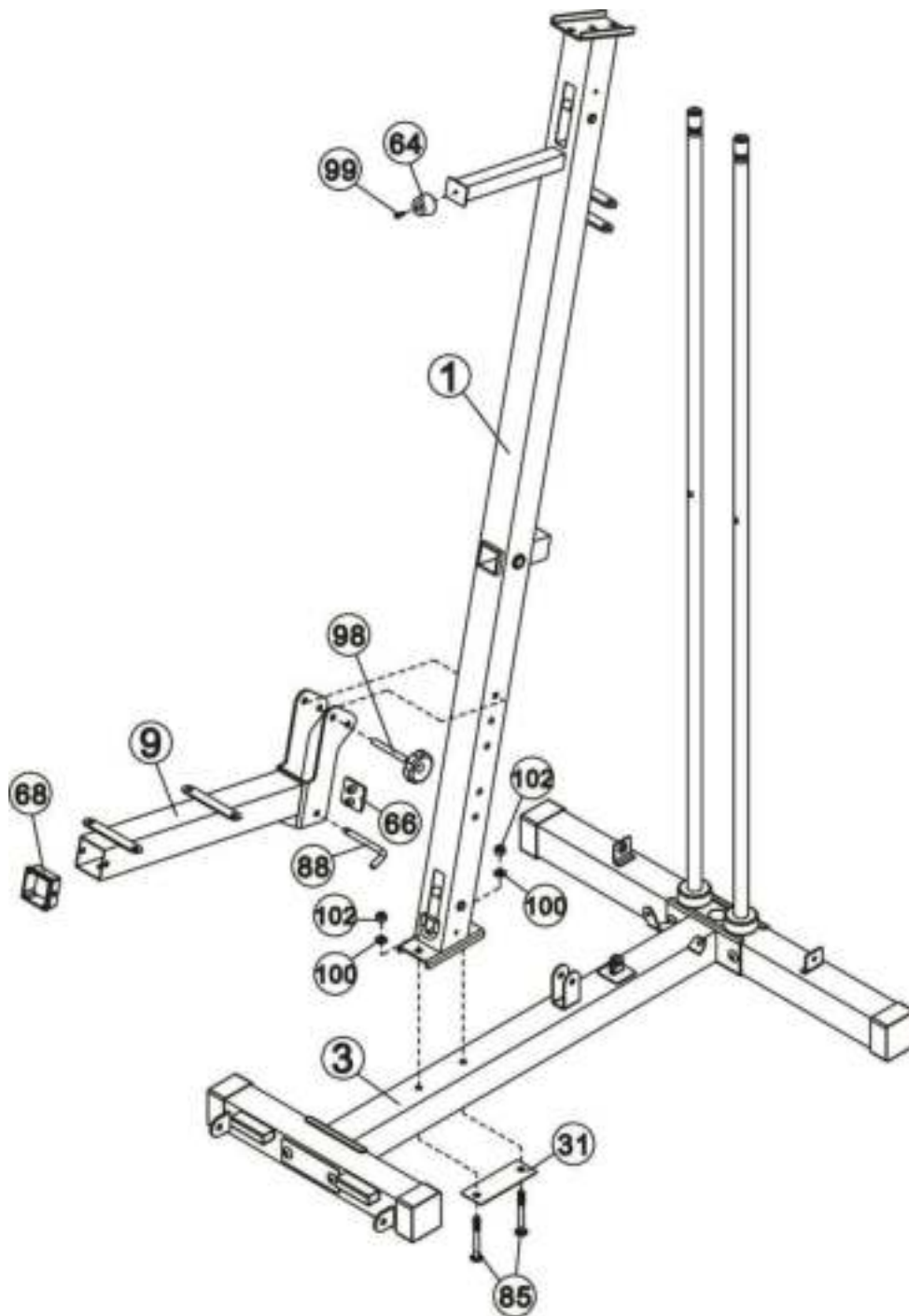

Step 2

- (A) Attach the front vertical frame (1) onto the main base frame(3) , carefully align the holes and secure them with 2 pcs M10×85 carriage bolts(85), one pc bracket (31),2pcs 2pcsØ10 washer(100) and 2 pcs M10 Aircraft nut(102).
- (B) Attach the seat pad support(9) to the front vertical frame(1) and secure them with M10*93 Lock knob(98) and one pc select pin(88)

Assembly instructions

Step 3

(A). Slide the 14pcs weight plate(35) along the guide rods (5) from the top to the bottom.insert the selector rod (19) into the hole of weight plates.and then place the weight selector(34) onto the selector rod (19)

(B) Attach the foot plate (14) to the front stabilizer(13), Secure them with 2pcs M10*20 Allen bolt(92), 2pcsØ10 washer(100) and one pc Foot plate tube(18).

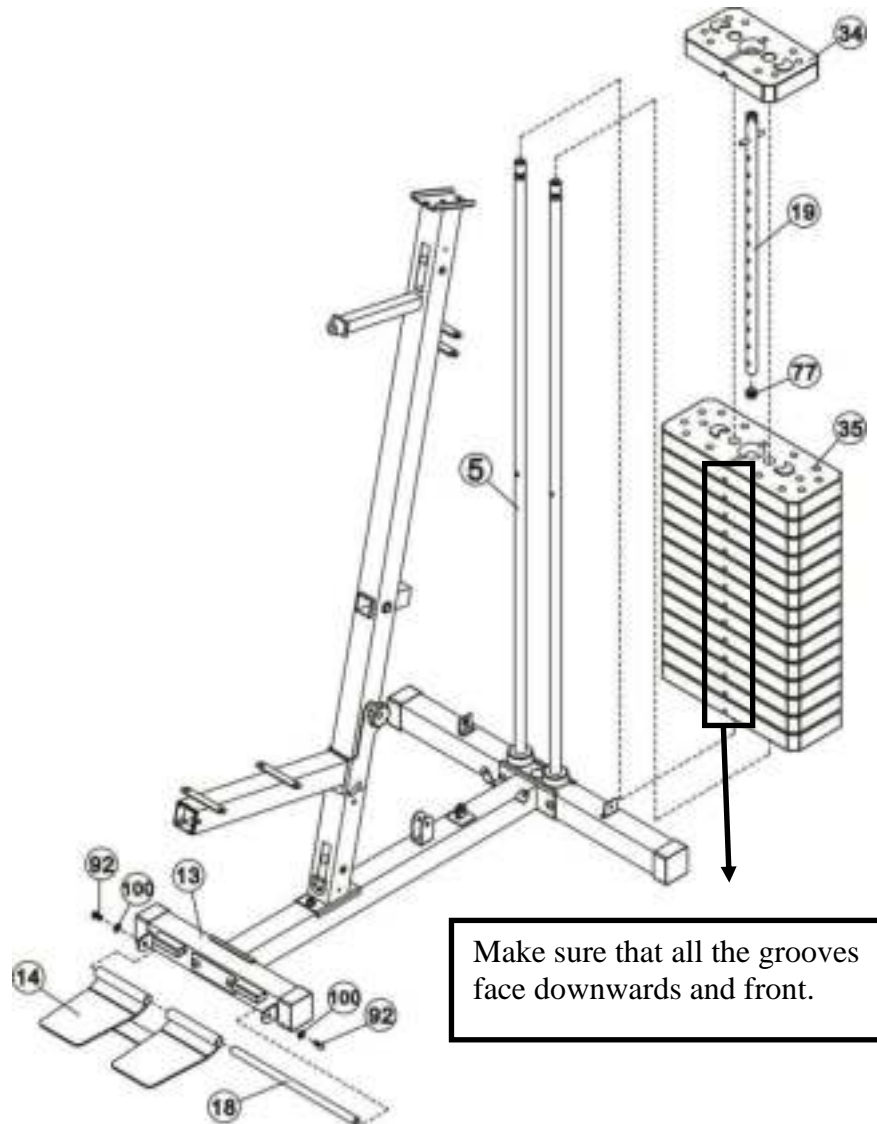

Assembly instructions

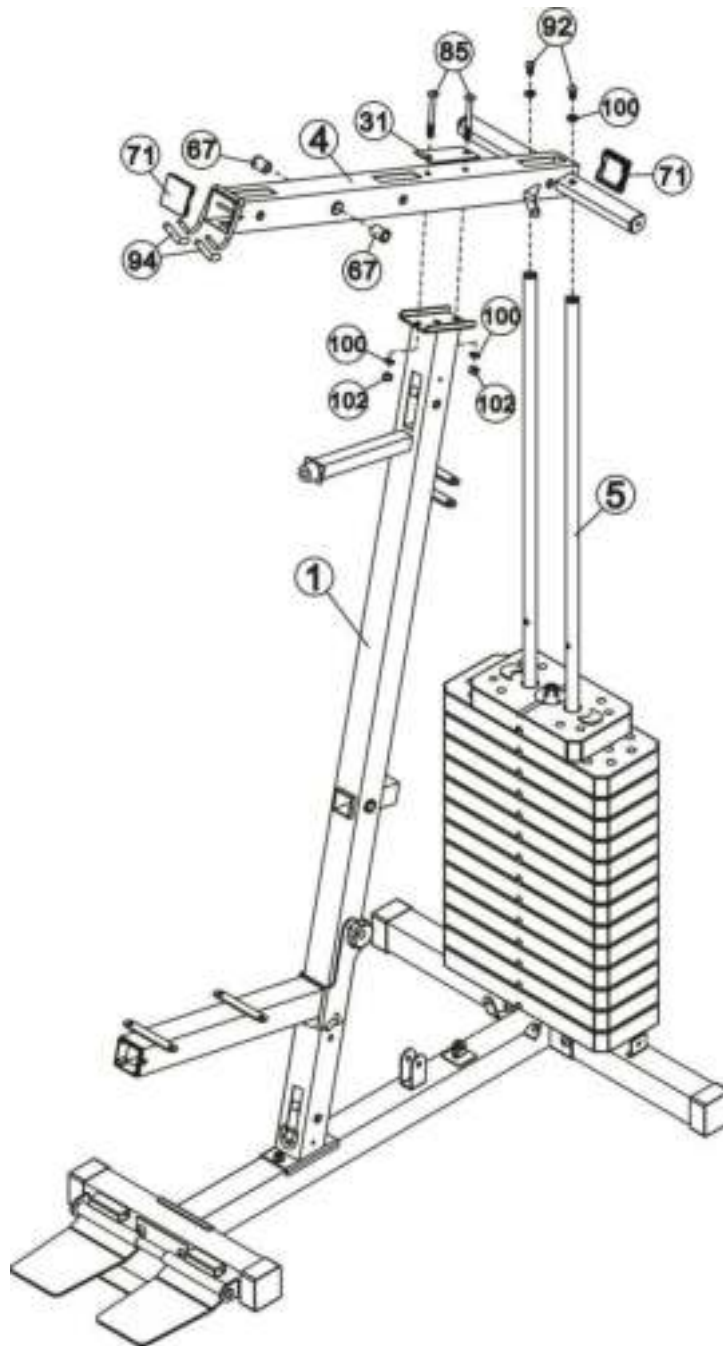

Step 4

Place the upper frame (4) onto the front vertical frame (1) and 2 pcs guide rods (5), Carefully align the holes and secure them with 2pcs M10*20 Allen bolt (92), 2pcs Ø10 washers (100). 2pcs M10*85 Carriage bolts(85), one pc bracket(31), 2pcsØ10 washers (100) and 2pcs M10 aircraft nuts(102).

Assembly instructions

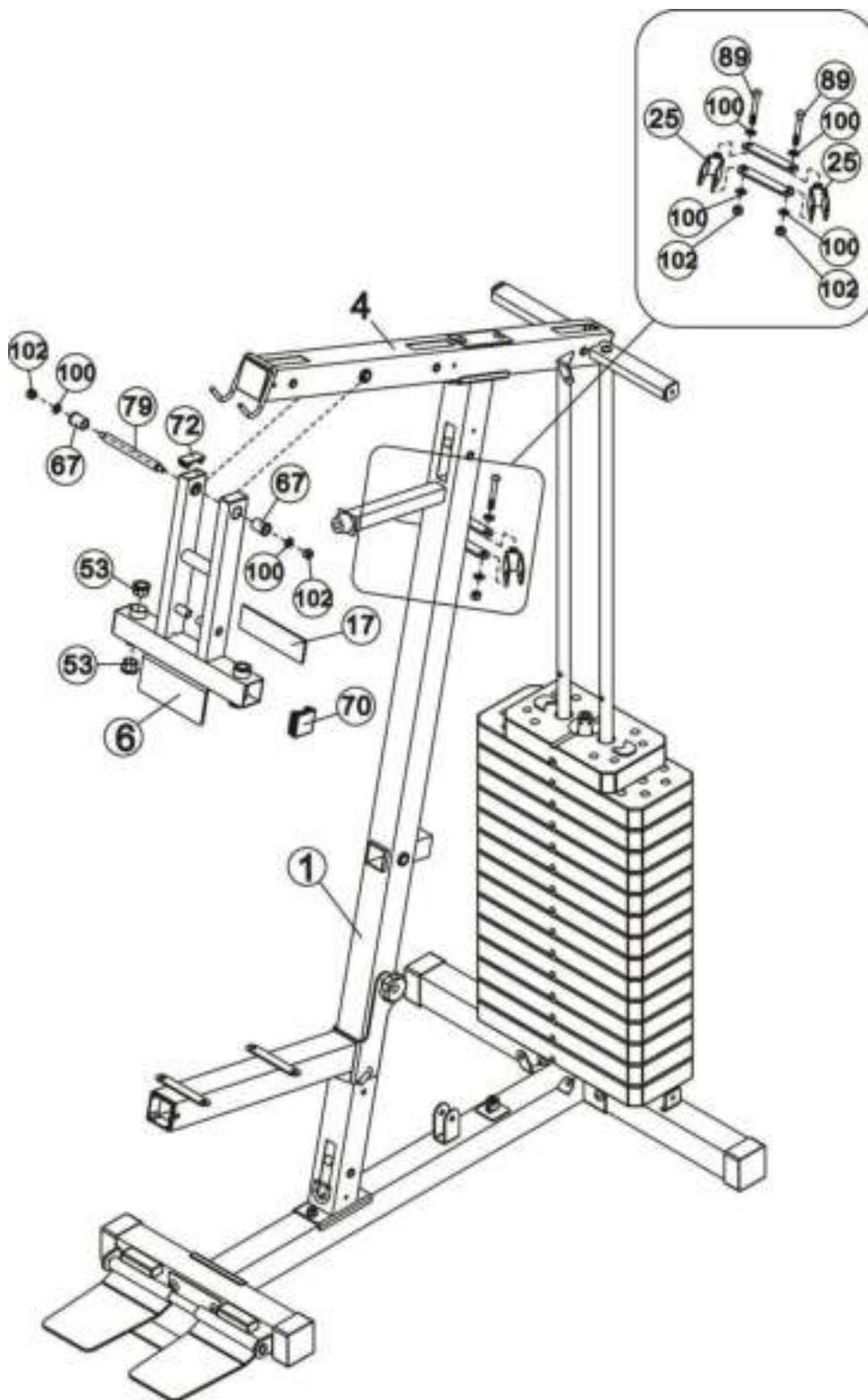

Step 5

(A). Attach the front press base(6) to the upper frame(4), Secure them with one pc $\text{Ø}16 \times \text{M}10 \times 169$ axle(79), 2 pcs $\text{Ø}25 \times 28$ bush(67), 2 pcs $\text{Ø}10$ washers (**100**) and 2 pcs M10 aircraft nuts(**102**).

(B) Fix the swivel pulley bracket (25) with M10*65 Allen bolt (89), 2 pcs $\text{Ø} 10$ washers(100) and M10 aircraft nut (102). Install another one with the same way.

Assembly instructions

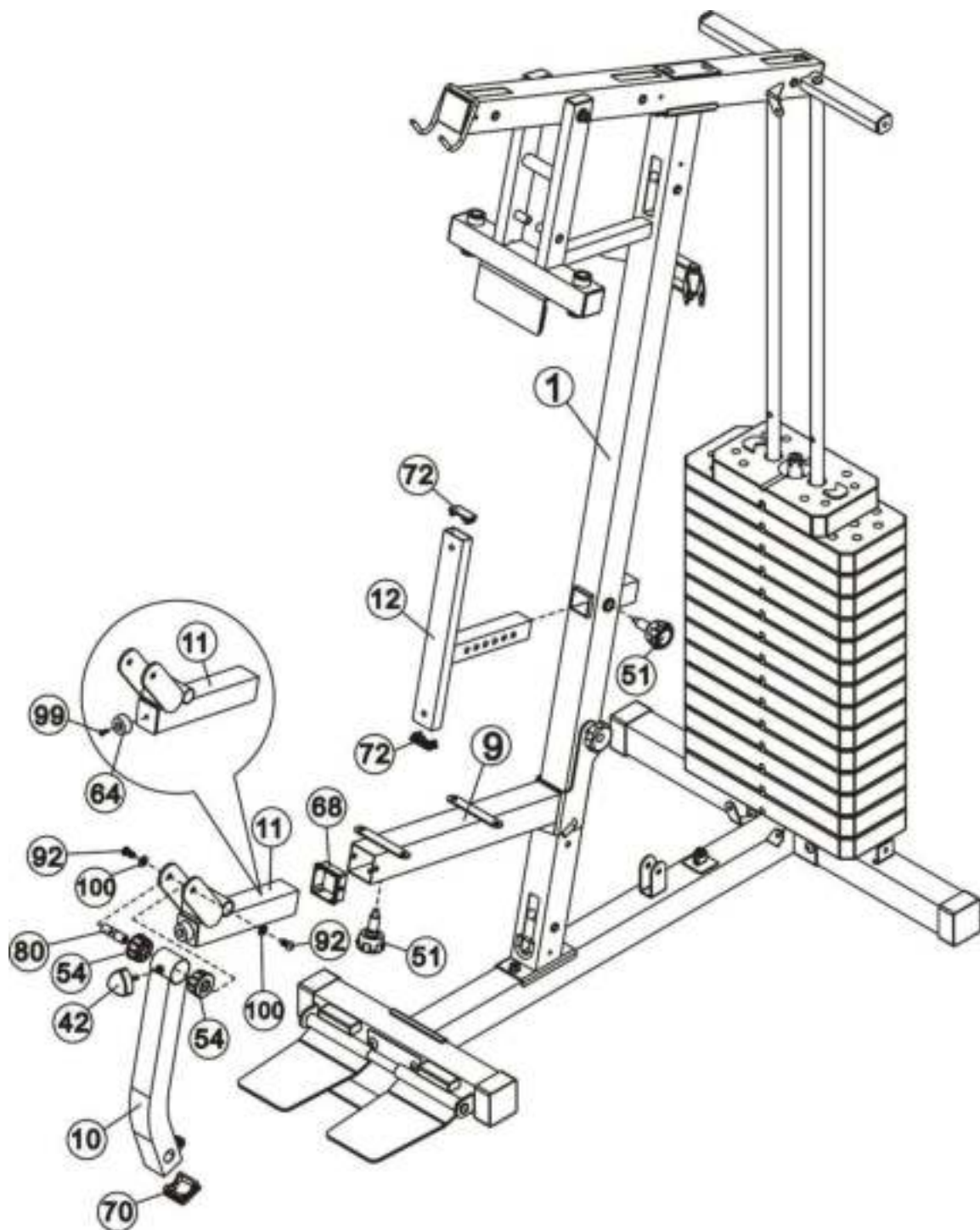

Step 6

- (A) Insert the backrest pad support (12) into the opening of the front vertical frame(1), You would Select the desired position with Lock knob (51) when exercising.
- (B) Insert the leg developer holder(11) into the frong opening of seat pad support(9). You would select the desired position with Lock knob (51).
- (C) Attach the leg developer(10) to the bracket as the diagram shows, Secure them with one pc $\text{\O}10*\text{M}10*56$ axle (80),2 pcs $\text{M}10*20$ Allen bolt(92) and 2pcs $\text{\O}10$ washers (100) .

Assembly instructions

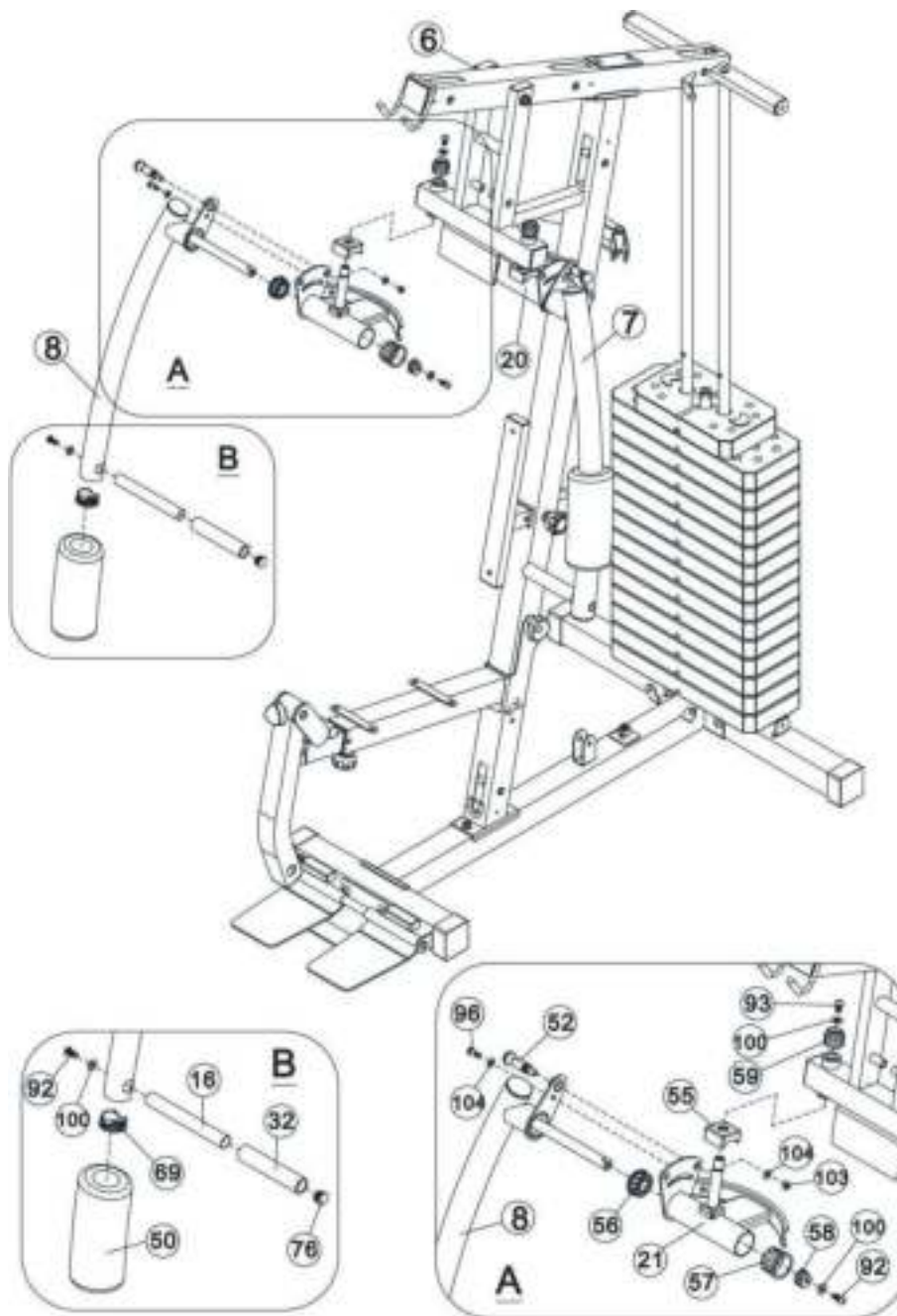

- (A) Place one pc plastic cover (55) through the post as the diagram shows. And attach the right butterfly adjustment frame(21) to the front press base,Secure them with one pc Lock ring(59), one pc $\text{\O}10$ washers (100) and one pc M10*16 Allen bolt(93).
- (B) Insert the right butterfly (8#) into the hole as the diagram shows,Secure them with one pc $\text{\O}50*20$ bushing(56), one pc $\text{\O}50*35$ bushing(57),one pc spacer(58), one pc $\text{\O}10$ washers (100),one pc M10*20 Allen bolt(92), one pc quick release lock pin (52), one pc $\text{\O}8$ washer (101) and one pc M8 aircraft nut(103). You would adjust the desired butterfly position with the quick release lock pin(52) when exercising.
- (C) Attach the butterfly foam roll(50) to the right butterflyfrom the bottom as the diagram shows.
- (D) Attach the butterfly handle (16) to the right butterfly and secure them with one pc M10*20 Allen bolt(92) and one pc $\text{\O}10$ washers (100).
- (E) Install the left butterfly (7) with the same way .

Assembly instructions

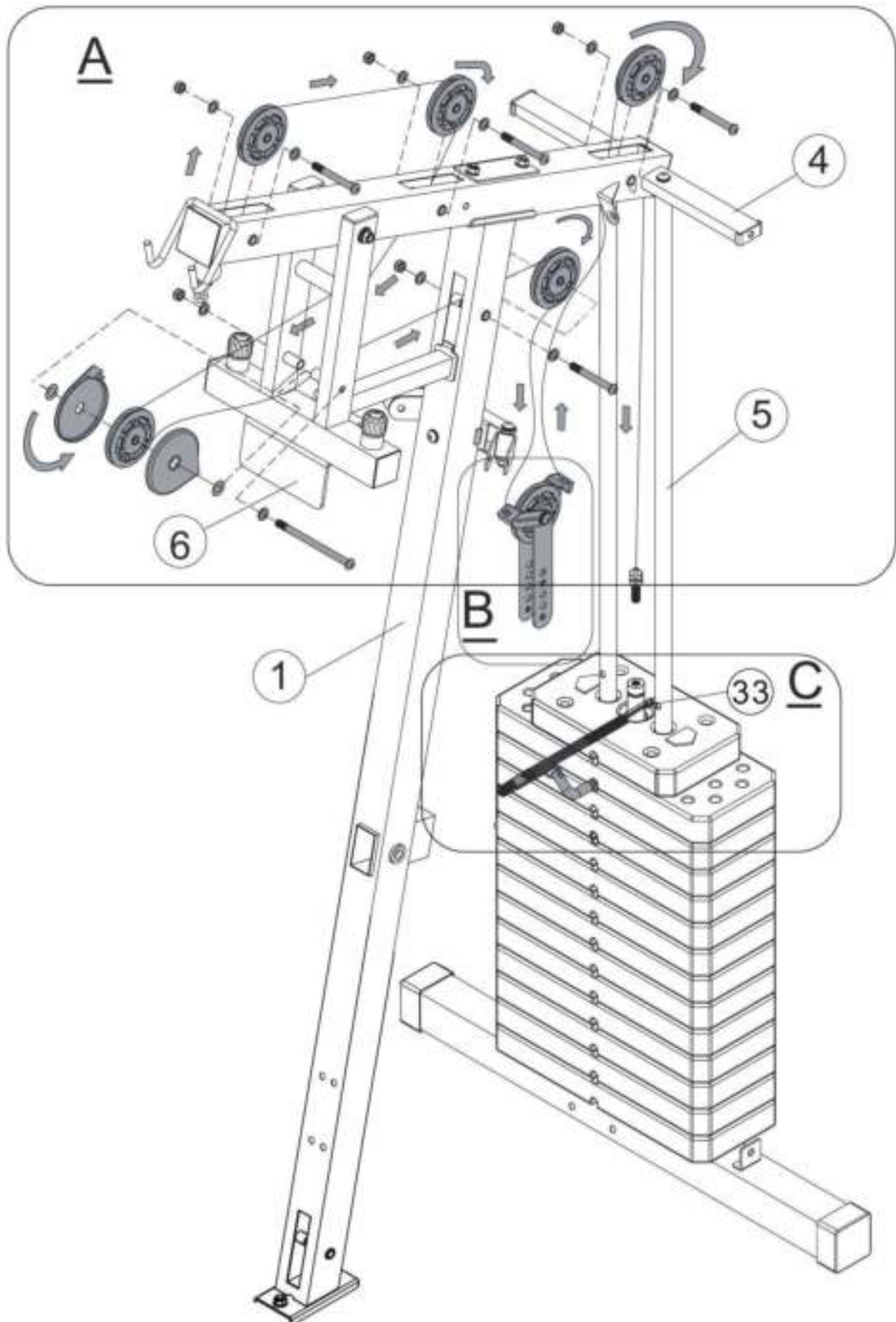

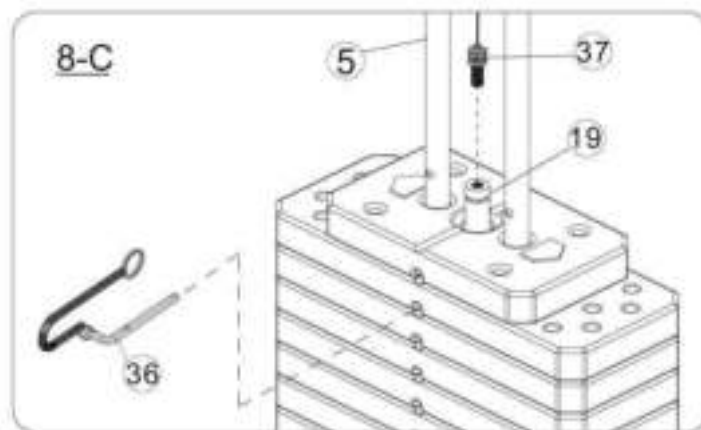
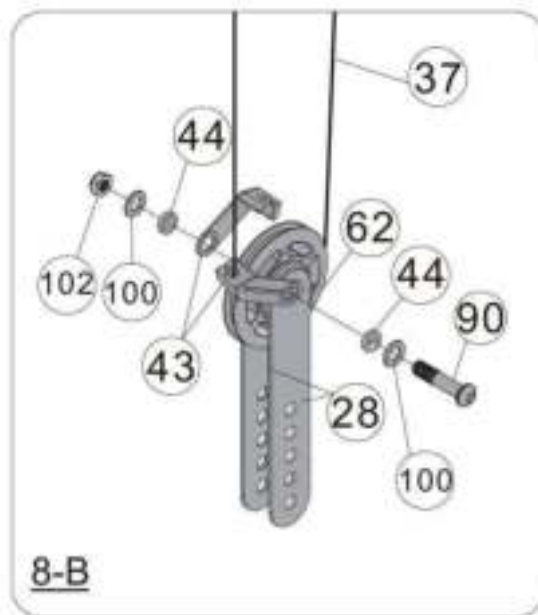
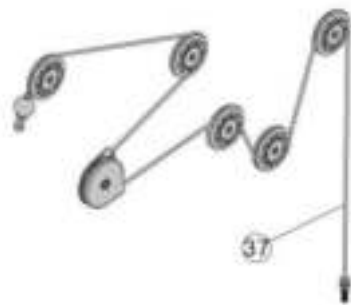
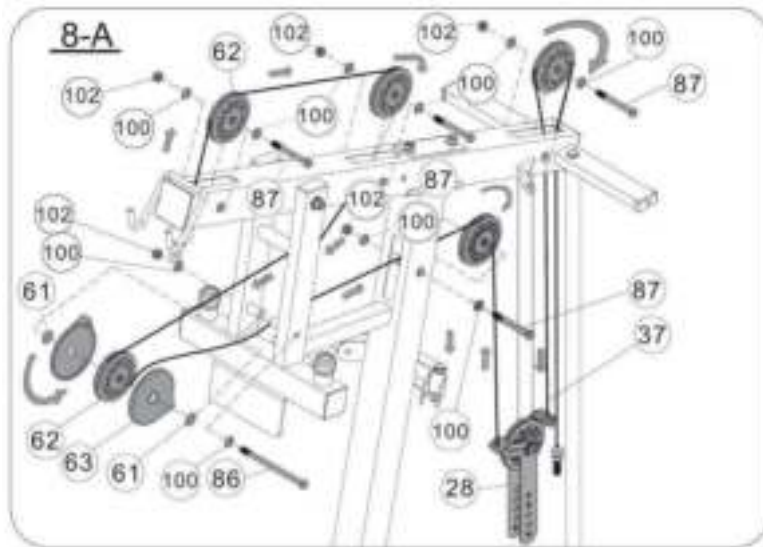

Step 8

- (A) Attach the upper cable through the first opening and make sure that the ball stopper should be underneath the upper frame. Place one pc pulley (62) below the cable and secure them with one pc M10*85 allen bolt (87) , 2 pcs Ø 10 washer (100) and one pc M10 aircraft nut (102).
- (B) Draw the cable backwards and place one pc pulley below the cable, secure the pulley with the same way shown in (A).
- (C) Draw the cable as the diagram shows and place one pc pulley (62) and 2 pcs pulley cover (63) below the cable, Secure them with one pc M10*150 allen bolt (86), 2 pcs Ø10 washers (100), 2 pcs Ø30X Ø10.5 washer (61) and one pc M10 aircraft nut (102).
- (D) Draw the cable around the pulley and backwards and go through the opening of front vertical frame, Secure them with one pc M10*85 allen bolt (87), 2 pcs Ø10 washers (100) and one pc M10 aircraft nut (102).
- (E) Draw the cable downwards and place one pc pulley onto the cable, Secure 2 pcs cable retainer (43), 2 pcs double floating pulley bracket (28) with the pulley together with one pc M10*50 Allen bolt (90), 2 pcs Ø10 washers (100), 2 pcs cable retainer bushing (44) and one pc M10 aircraft nut (102).
- (F) Draw the cable upwards and go through the last opening of the upper frame, Place one pc pulley below the cable and secure it with the same way shown in (A).
- (G) Insert the selector lock pin (36) into the hole to select the desired weight when exercising .Place the ring of the lock pin through the top of the select rod .
- (H) Draw the cable around the pulley and downwards ,Attach the end bolt to the top of selector rod, Thread at least 5 laps to ensure the safety.

Assembly instructions

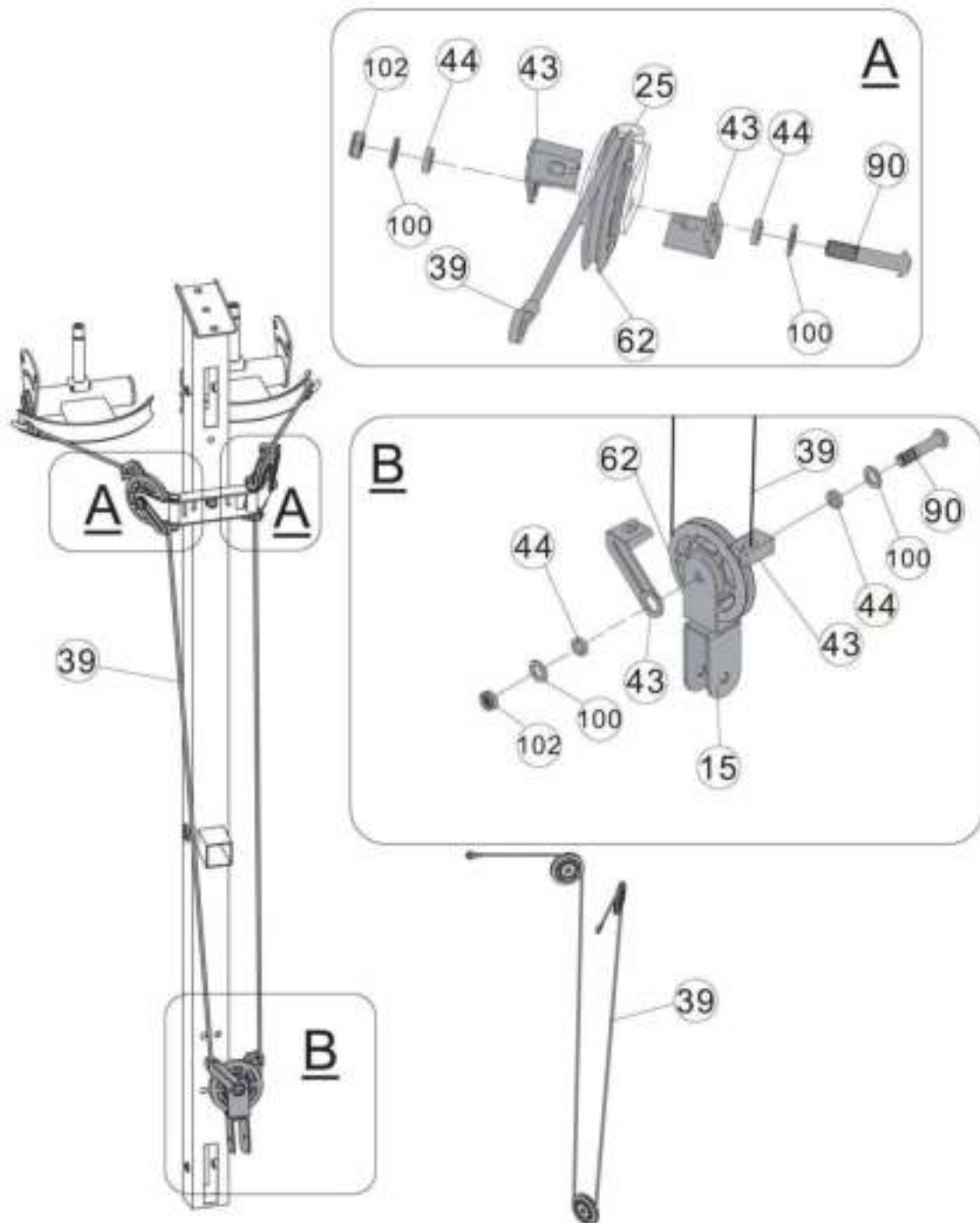

Step 9

- (A). Attach one end of the butterfly cable (39) to the post of the right butterfly adjustment frame(21), Draw the cable backwards and place one pc pulley below the cable. Secure the 2 pcs cable retainer(43) with the pulley together with one pc M10*50 Allen bolt(90), 2 pcs Ø10 washers (100),2 pcs cable retainer bushing (44) and M10 aircraft nut(102).
- (B) Draw the cable downwards and place one pc pulley onto the cable. Secure the pulley , 2 pcs cable retainer(43) and angled floating pulley bracket(15) with the same way in A.
- (C) Draw the cable upwards and repeat the procedure A to fix another end of cable to the post of left butterfly adjustment frame(20).

Assembly instructions

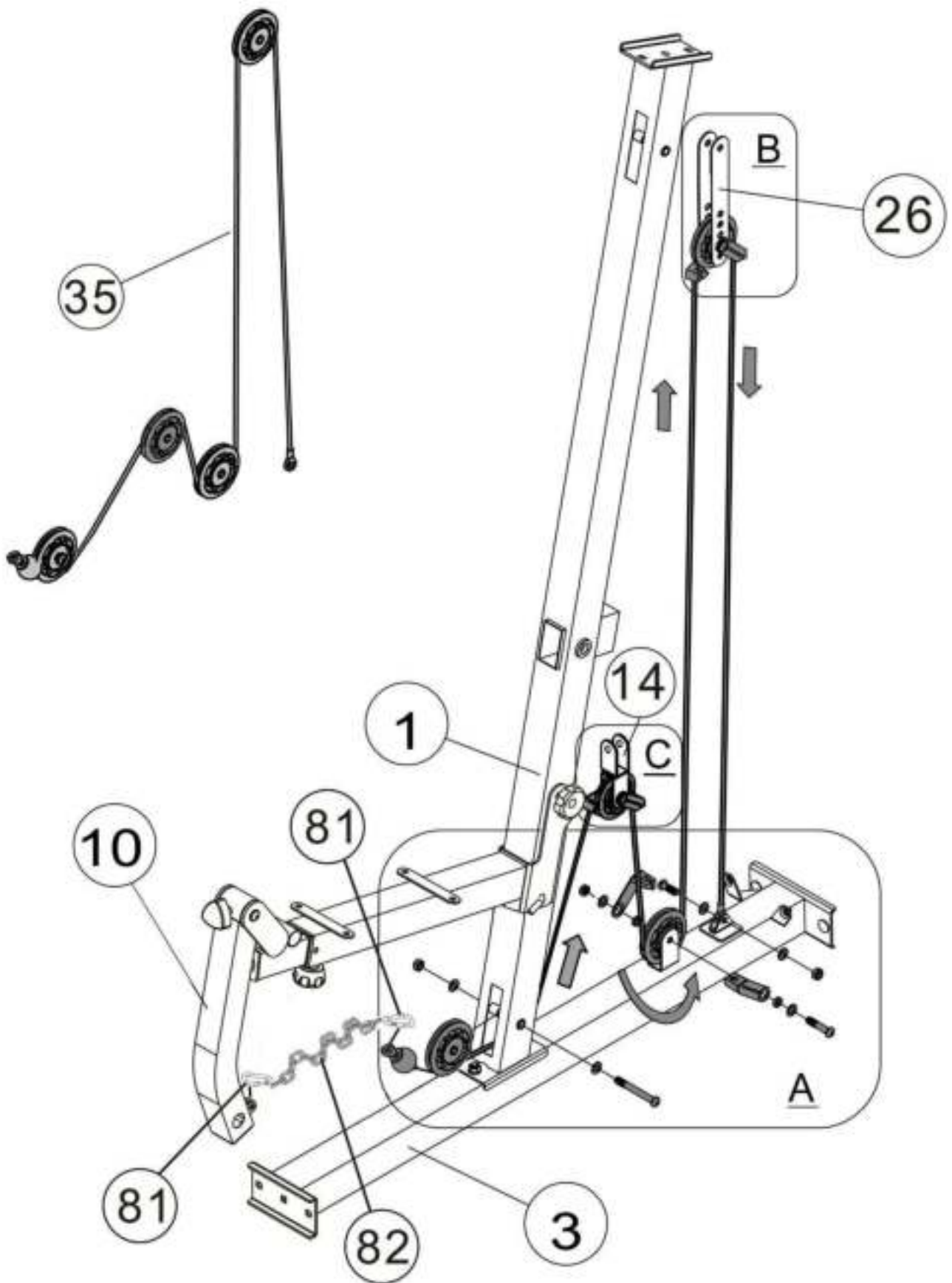

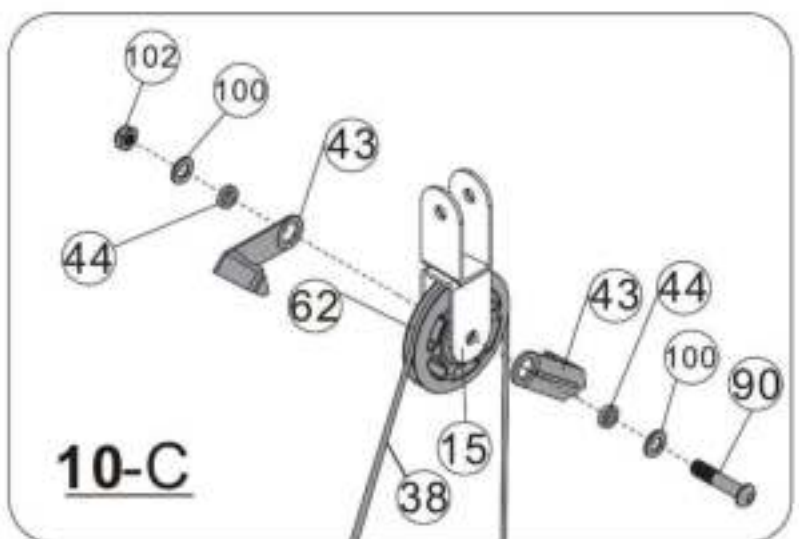
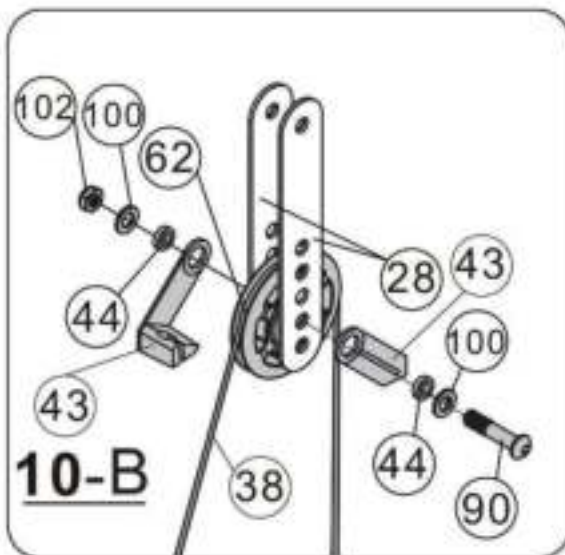
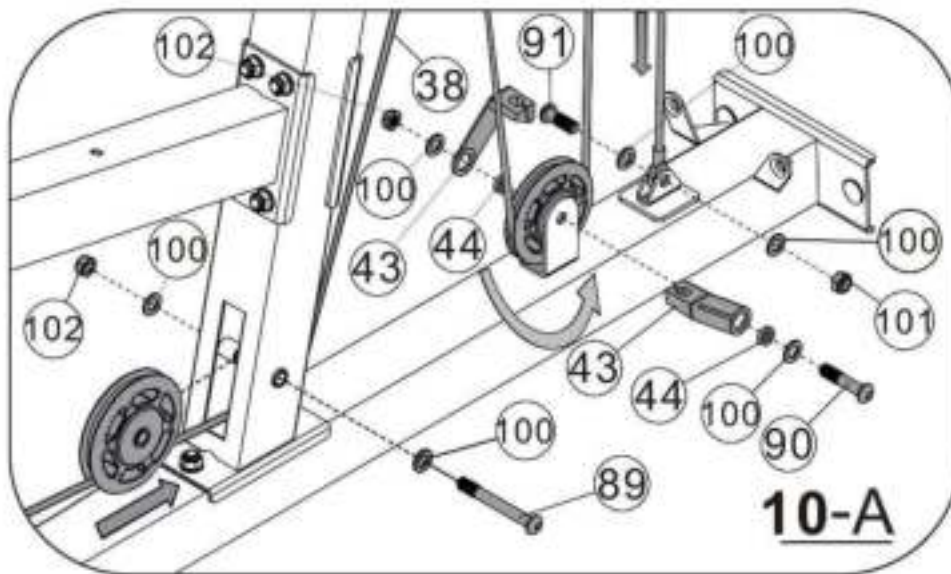

Step 10

- (A) Draw the lower cable(35) through the first opening,make sure that the ball stopper should be in front of the opening. Place one pc pulley onto the lower cable, Secure the pulley with one pc M10*65 allen bolt(89), 2 pcs Ø10 washers (100) and one pc M10 aircraft nut(102) .
- (B) Draw the cable as the diagram shows and reach the angled floating pulley bracket(15),Place one pc pulley below the cable , and secure the angled floating pulley bracket(15),pulley (62), 2 pcs cable retainer(43) together with one pc M10*50 Allen bolt(90), 2 pcs Ø10 washers (100),2 pcs cable retainer bushing (44) and M10 aircraft nut(102).
- (C) Place one pc pulley onto the cable and secure it with the same way in (B)
- (D) Draw the cable upwards and reach the double floating pulley bracket(28),Repeat the same way in (B) to install the pulley and 2 pcs cable retainer(43).
- (E) Draw the cable around the pulley and downwards , Secure the end with one pc M10*30 allen bolt(91), 2 pcs Ø10 washers (100) and one pc M10 aircraft(102).
- (F) Connect the leg developer(10) and the end of lower cable with 2pcs 7# gourd hook(81) and one pc 15-joint chain(82)

Assembly instructions

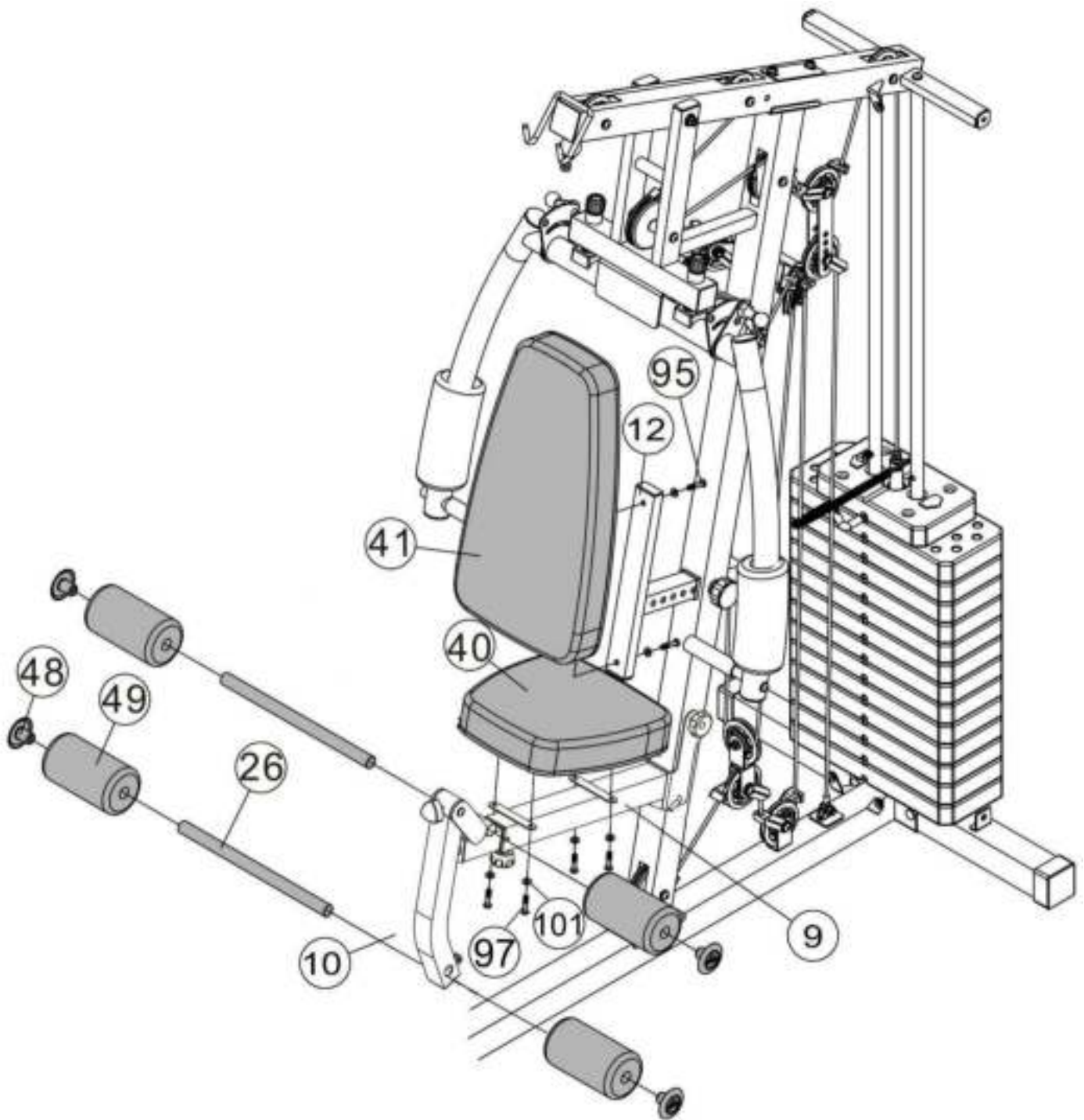

Step 11

- (A) Attach the backrest pad(41) to the backrest pad support(12) , Align the holes and secure them with 2 pcs M8*40 allen bolt(95) and 2 pcs Ø8 washers (101) .
- (B) Place the seat pad(40) onto the seat pad support (9), Secure them with 4pcs Ø8 washer(101) and 4pcs M8*18 allen bolt (97).
- (C) Insert the 2 pcs foam roll tube(26) into the holes halfway, and then push the 4pcs foam rolls(49) from both ends separately, and then push the foam roll end cap (48).

Assembly instructions

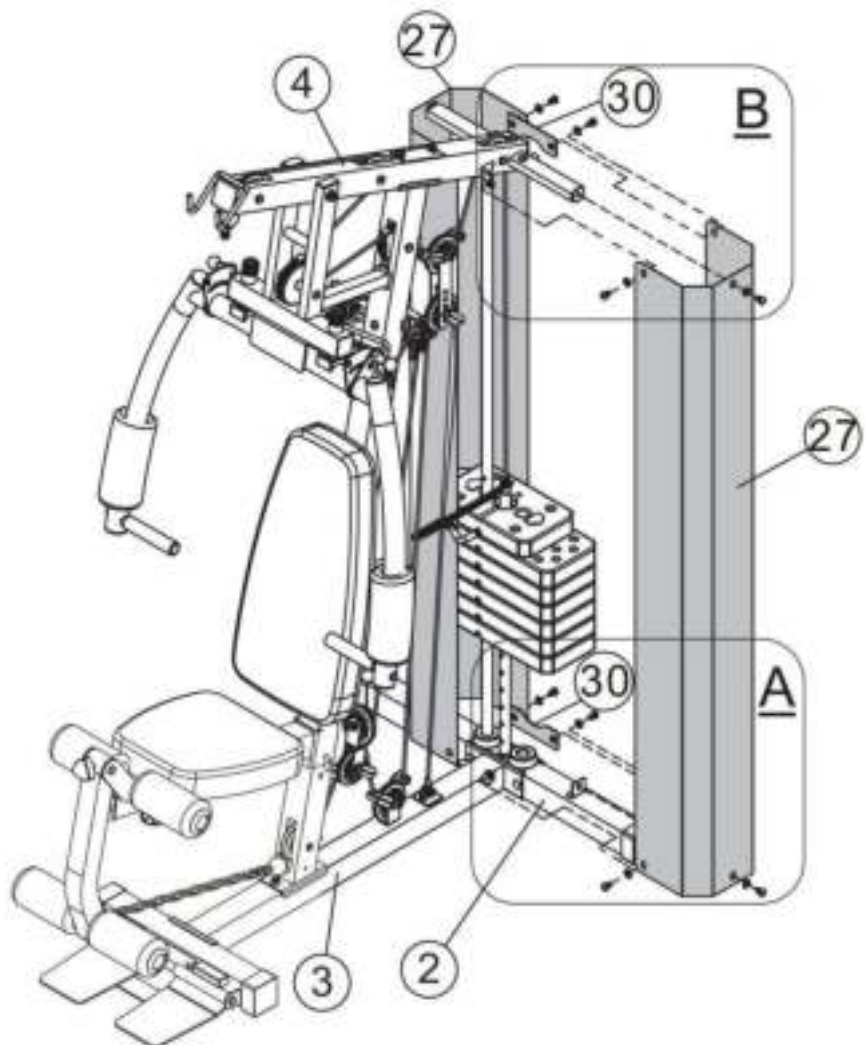
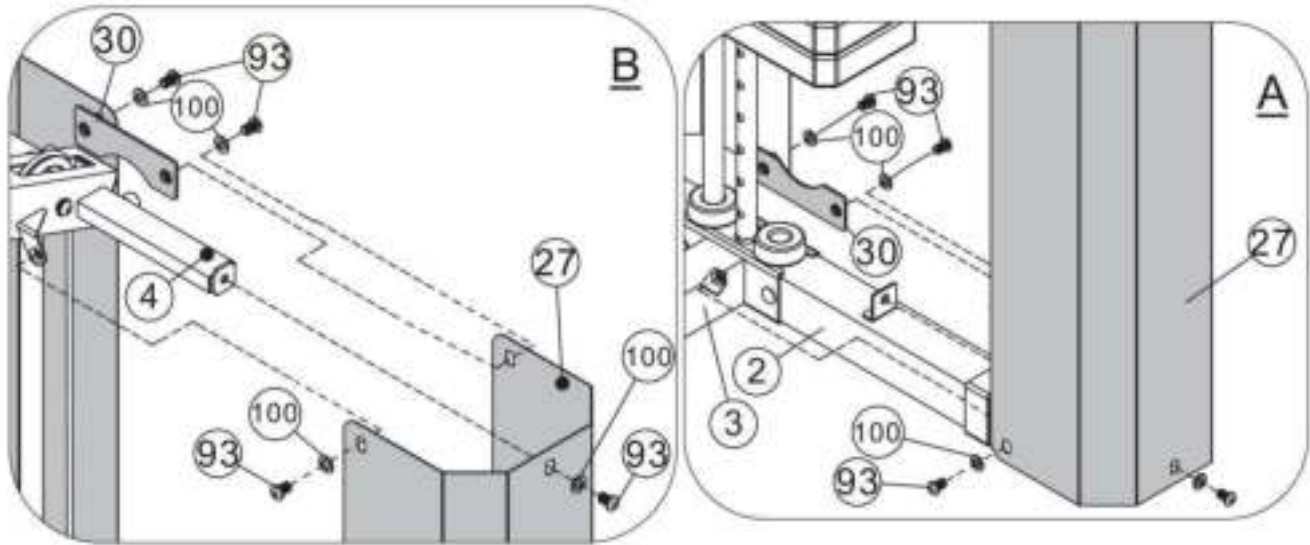

Step 12

Attach the 2 pcs weight stack covers (27) onto the rear stabilizer and secure them with 12 pcs M10X6 Allen bolt (93) , 12 pcs Ø10 washer(100) and 2 pcs bracket(30) .

Assembly instructions

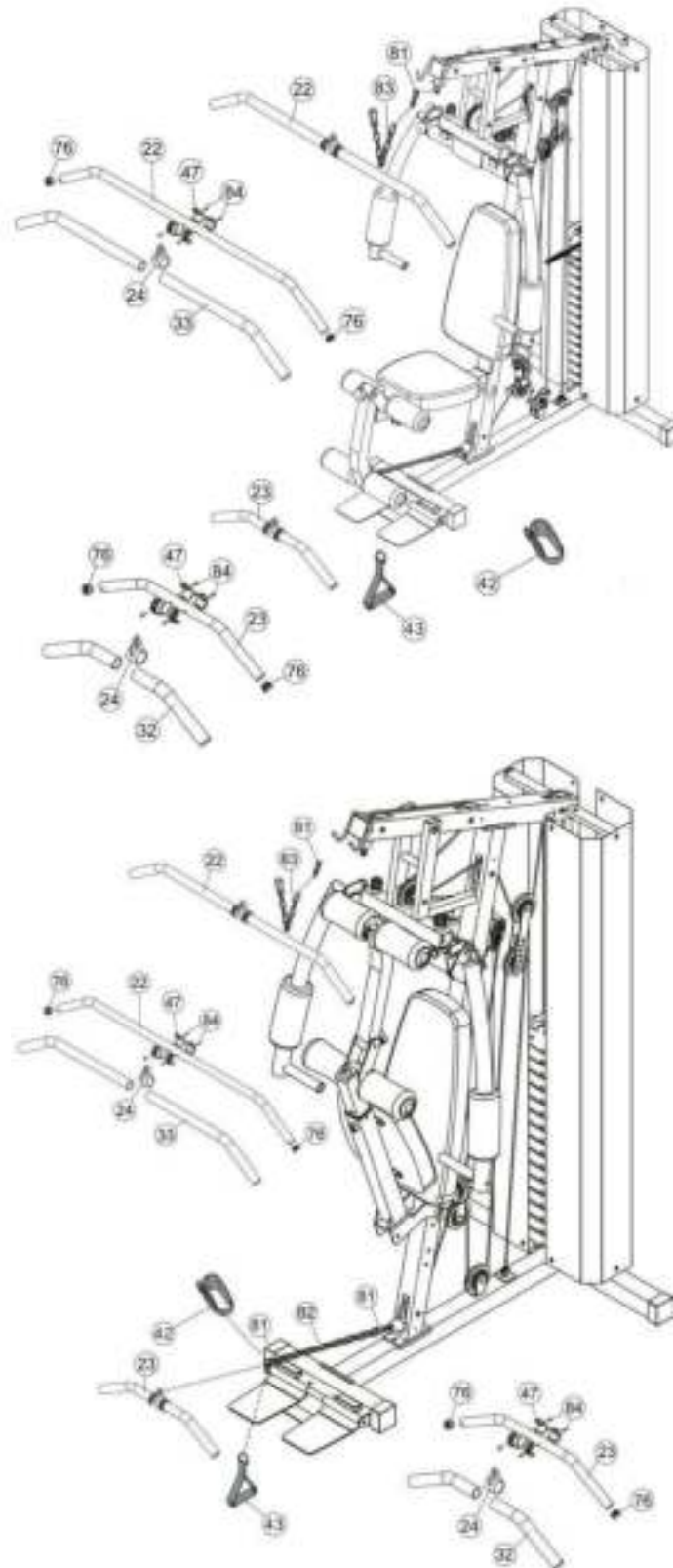

Step 13

- (A) Connect the lat bar (32#) to the end of the upper cable with 2pcs gourg hook(81) and one pc 10 joint chain(83).
- (B) Fold the seat pas support as the diagram shows,Connect the shiver bar (23#) or single strap(43) or angle strap(42) to the end of the lower cable when exercising.
- (C) Please place all the nut cover (42#)on the bolt .

Care and Maintenance

1. The safety level of the equipment can only be maintained if it is examined regularly for damage and wear e.g. connection points.

2. Lubricate moving parts with light oil periodically to prevent premature wear.

3. Inspect and tighten all parts before using the equipment, replace any defective parts immediately, and do not use

the equipment again until it is in perfect working order.

4. The equipment can be cleaned using a damp cloth and mild non-abrasive detergent. **Do not** use solvents.

5. Do not attempt to repair this equipment yourself. Should you have any difficulty with assembly, operation or use of your exercise product or if you

think that you may have parts missing, contact the customer helpline:

Please add your tel no. and website here.

Guarantee:

For guarantee purposes, please retain your purchase receipt.

Free area and training area

The free area should be no less than 0.6m greater than the training area in the directions from which the equipment is accessed. The free area must also include the area for emergency dismount. Where equipment is positioned adjacent to each other the value of the free area may be shared.

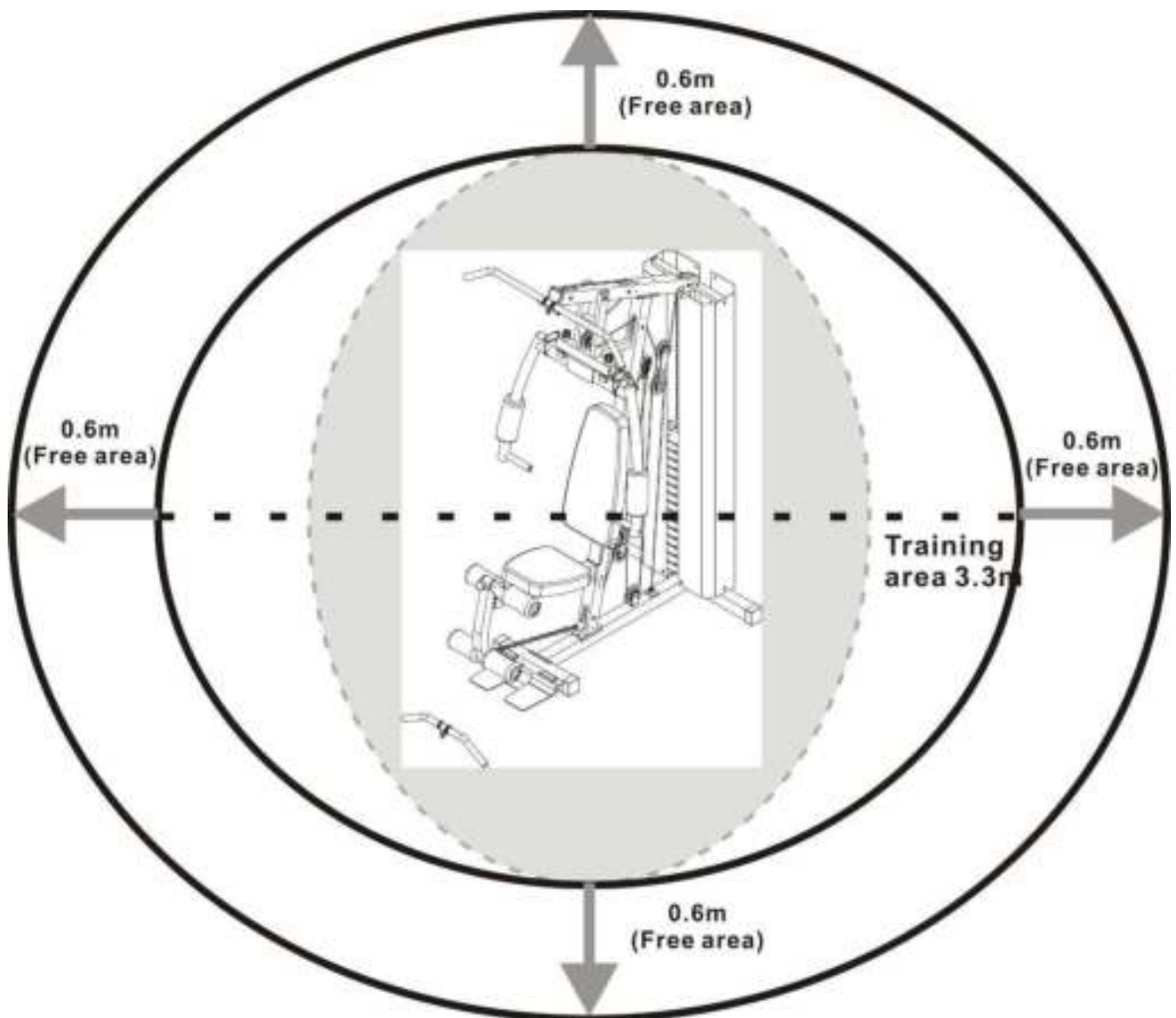

MSX-70 WEIGHT RESISTANCE CHART					
Weight Plate	Front Press	Back Press	Butterfly	Lat Pull	Low Pulley
1	12.7	12.2	5.4	12.7	12.7
2	21.5	19.0	8.5	20.0	20.0
3	30.2	26.0	11.6	27.3	27.3
4	39.0	33.0	14.7	34.6	34.6
5	47.7	39.9	17.8	41.9	41.9
6	56.5	46.9	20.9	49.2	49.2
7	65.3	53.8	24.0	56.5	56.5
8	74.0	60.8	27.1	63.8	63.8
9	82.8	67.7	30.5	71.1	71.1
10	91.5	75.6	33.6	79.4	79.4
11	100.3	81.6	36.7	85.7	85.7
12	109.1	88.6	39.8	93.0	93.0
13	117.8	95.5	42.9	100.3	100.3
14	126.5	103.5	46.0	107.6	109.0



= 6.8 kg

Exploded Parts List

Part	Description	Qty.	Part	Description	Qty.
1	Front vertical frame	1	22	Lat bar	2
2	Rear stabilizer	1	23	Shiver bar	1
3	Main base frame	1	24	Rotate ring	2
4	Upper frame	1	25	Swivel pulley bracket	2
5	Guide rod	2	26	Foam roll tube	2
6	Front press frame	1	27	Weight stack cover	2
7	Left butterfly	1	28	Double floating pulley bracket	2
8	Right butterfly	1	29	bracket	1
9	Set pad support	1	30	Weight stack cover bracket	2
10	Leg developer	1	31	bracket	3
11	Leg developer holder	1	32	Ø25x255 Handle grip	2
12	Backrest pad support	1	33	Ø25x520 Handle grip	2
13	Front stabilizer	1	34	Weight selector	1
14	Foot plate	1	35	Weight plate	14
15	angled floating pulley bracket	2	36	Selector rod	1
16	Buterfly handle	2	37	Upper cable	1
17	Anti slip	1	38	Lower cable	1
18	Foot plate tube	1	39	Butterfly cable	1
19	Selector rod	1	40	Seat pad	1
20	Left butterfly adjustment frame	1	41	Backrest pad	1

Exploded Parts List

43	Cable retainer	14	66	48X48 rubber bumper	1
44	Cable retainer bushing	14	67	Ø25x 28 bushing	4
45	Angle strap	1	68	□ 60×50 sleeve	1
46	Single strap	1	69	Ø50*1.5 end cap	4
47	Plastic ring	8	70	□ 50*2 end cap	3
48	Foam roll end cap	4	71	□ 65*1.5 end cap	2
49	Foam roll	4	72	25*50 enc cap	4
50	Buttrerfly foam roll	2	73	foot	4
51	Lock knob	2	74	□38 x1.5 End Cap	1
52	Quick release lock pin	2	75	20*30*2 End Cap	4
53	Ø32x Ø20 bushing	4	76	Ø25 x 1.5 End cap	6
54	Ø50x Ø16 bushing	2	77	Dome end cap	1
55	Plastic cover	2	78	Combination lock	1
56	Ø32x 20 bushing	2	79	Ø 16xM10x169 Axle	1
57	Ø32x 35 bushing	2	80	Ø 16xM10x56 Axle	1
58	Spacer	2	81	7# Gourd hook	4
59	M18 Lock ring	2	82	15 joint Chain	1
60	Ø25x 150 handle grip	2	83	10 joint Chain	1
61	Ø30x Ø 10.5 washer	2	84	Ø4×15 clinch bolt	8
62	Pulley	13	85	M10 x 85 Carriage bolt	8
63	Pulley cover	2	86	M10x 150 Allen bolt	1

64	Small rubber bumper	2	87	M10x 85 Allen bolt	5
65	Rubber bumper	2	88	Ø10x100x35 L shape lock pin	1

33

89	M10x 65 Allen bolt	2
90	M10x 50 Allen bolt	7
91	M10x 30 Allen bolt	1
92	M10x 20 Allen bolt	12
93	M10x 16 Allen bolt	14
94	Ø8x50 Handle grip	2
95	M8x 40 Allen bolt	2
96	M8x 22 Allen bolt	2
97	M8x 18 Allen bolt	4
98	M10X93 Lock knob	1
99	M6X16 philips screw	2
100	Ø10 washer	68
101	Ø8 washer	6
102	M10 aircraft nut	30
103	M8 aircraft nut	2
104	Nylon washer	4



GARLANDO SPA
Via Regione Piemonte, 32 - Zona Industriale D1
15068 - Pozzolo Formigaro (AL) - Italy
www.toorx.it - info@toorx.it