



APPLICATION FOR ELECTROMAGNETIC COMPATIBILITY DIRECTIVE

On Behalf of
Shenzhen xinshijie Industrial Co., Ltd.

Gaming mouse

Model No.:

A869RGB, A866, A867, A868, A869, A876, A883, A885, A888,
A903, A904, A905, A906, A907, A908, H100, H200, H300,
H400, H500, H600, H700, H800, H900, X100, X200, X300,
X400, X500, X600, X700, X800, X900, J200, J300, J400, J500,
J600, J700, J800, J900, X300GY, S100, S200, S300, S400, S500,
S600, S700, S800, S900

Prepared for : Shenzhen xinshijie Industrial Co., Ltd.
201F, Building C, Chao loft Culture Creative Park, No. 150,
Address : Huayue Road, Longkou Community, Dalang Street, Longhua
District, Shenzhen, Guangdong Province, China

Prepared By : Shenzhen Alpha Product Testing Co., Ltd.
Building i, No.2, Lixin Road, Fuyong Street, Bao'an District,
Address : 518103, Shenzhen, Guangdong, China

Report Number : A2006193-C02-R02
Date of Receipt : June 19, 2020
Date of Test : June 19-23, 2020
Date of Report : June 24, 2020
Version Number : V0

TABLE OF CONTENTS

Description	Page
1. General Information	7
1.1. Description of Device (EUT).....	7
1.2. Accessories of Device (EUT)	7
1.3. Tested Supporting System Details	8
1.4. Block Diagram of connection between EUT and simulators.....	8
2. Summary Of Standards And Results	9
2.1. Description of Standards and Results	9
2.2. Test Mode Description.....	10
2.3. Test Equipment List.....	11
2.4. Test Facility	14
2.5. Measurement Uncertainty	14
3. Conducted Emissions At Mains Terminals Test.....	15
3.1. Test Limit.....	15
3.2. Block Diagram of Test Setup.....	15
3.3. Configuration of EUT on Test	16
3.4. Operating Condition of EUT	16
3.5. Test Procedure	16
3.6. Conducted Emissions at Mains Terminals Test Results	17
4. Radiated Emissions Test	18
4.1. Test Limit.....	18
4.2. Block Diagram of Test Setup.....	19
4.3. Configuration of EUT on Test	20
4.4. Operating Condition of EUT	20
4.5. Test Procedure	21
4.6. Radiated Emissions Test Results	22
5. Harmonic Current Test	26
5.1. Test Limit.....	26
5.2. Block Diagram of Test Setup.....	26
5.3. Configuration of EUT on Test	27
5.4. Operating Condition of EUT	27
5.5. Test Procedure	27
5.6. Harmonic Current Test Results.....	28
6. Voltage Fluctuations & Flicker Test.....	29
6.1. Test Limit.....	29
6.2. Block Diagram of Test Setup.....	29
6.3. Configuration of EUT on Test	29
6.4. Operating Condition of EUT	29
6.5. Test Procedure	29
6.6. Voltage Fluctuation and Flicker Test Results	30
7. Immunity General performance criteria.....	31
8. Electrostatic Discharge Test	32

8.1. Electrostatic Discharge Test Limits	32
8.2. Block Diagram of Test Setup.....	32
8.3. Configuration of EUT on Test	32
8.4. Operating Condition of EUT	32
8.5. Test Procedure	32
8.6. Electrostatic Discharge Test Results.....	34
9. RF Field Strength Susceptibility Test.....	35
9.1. Test Level.....	35
9.2. Block Diagram of Test Setup.....	35
9.3. Configuration of EUT on Test	36
9.4. Operating Condition of EUT	36
9.5. Test Procedure	36
9.6. RF Field Strength Susceptibility Test Results	37
10. Electrical Fast Transient/Burst Immunity Test.....	40
10.1. Test Level.....	40
10.2. Block Diagram of Test Setup.....	40
10.3. Configuration of EUT on Test	40
10.4. Operating Condition of EUT	40
10.5. Test Procedure	41
10.6. Electrical Fast Transient/Burst immunity Test Results	42
11. Surge Test.....	43
11.1. Test Level.....	43
11.2. Block Diagram of Test Setup.....	44
11.3. Configuration of EUT on Test	44
11.4. Operating Condition of EUT	44
11.5. Test Procedure	44
11.6. Surge Test Results.....	45
12. Injected Currents Susceptibility Test	46
12.1. Test Level.....	46
12.2. Block Diagram of Test Setup.....	46
12.3. Configuration of EUT on Test	46
12.4. Operating Condition of EUT	46
12.5. Test Procedure	47
12.6. Injected currents susceptibility Test Results.....	48
13. Magnetic Field Immunity Test	49
13.1. Test Level.....	49
13.2. Block Diagram of Test Setup.....	49
13.3. Configuration of EUT on Test	49
13.4. Operating Condition of EUT	49
13.5. Test Procedure	49
13.6. Magnetic field immunity Test Results.....	50
14. Voltage Dips and Interruptions Test	51
14.1. Test Level.....	51
14.2. Block Diagram of Test Setup.....	51
14.3. Configuration of EUT on Test	51

14.4. Operating Condition of EUT	51
14.5. Test Procedure	51
14.6. Voltage dips and interruptions Test Results	52
15. Photograph.....	53
15.1. Photo of Radiated emissions Test (In Semi Anechoic Chamber).....	53
15.2. Photo of Electrostatic Discharge Test.....	53
15.3. Photo of RF Field Strength Susceptibility Test	54
16. Photos Of The EUT	55

TEST REPORT DECLARATION

Applicant : Shenzhen xinshijie Industrial Co., Ltd.
 201F, Building C, Chao loft Culture Creative Park, No. 150, Huayue
 Address : Road, Longkou Community, Dalang Street, Longhua District, Shenzhen,
 Gongdong Province, China
 Manufacturer : Shenzhen xinshijie Industrial Co., Ltd.
 201F, Building C, Chao loft Culture Creative Park, No. 150, Huayue
 Address : Road, Longkou Community, Dalang Street, Longhua District, Shenzhen,
 Gongdong Province, China
 EUT Description : Gaming mouse
 A869RGB, A866, A867, A868, A869, A876, A883, A885,
 A888, A903, A904, A905, A906, A907, A908, H100,
 H200, H300, H400, H500, H600, H700, H800, H900,
 (A) Model No. : X100, X200, X300, X400, X500, X600, X700, X800,
 X900, J200, J300, J400, J500, J600, J700, J800, J900,
 X300GY, S100, S200, S300, S400, S500, S600, S700,
 S800, S900
 (B) Trademark : N/A

Measurement Standard Used:

EN 55032:2015

EN 55035:2017

The device described above is tested by Shenzhen Alpha Product Testing Co., Ltd. to determine the maximum emission levels emanating from the device and the severe levels of the device can endure and its performance criterion. The test results are contained in this test report and Shenzhen Alpha Product Testing Co., Ltd. is assumed full responsibility for the accuracy and completeness of test. Also, this report shows that the EUT is technically compliant with the EN 55032, EN 55035 requirements.

This report applies to above tested sample only. This report shall not be reproduced in parts without written approval of Shenzhen Alpha Product Testing Co., Ltd.

Tested by (name + signature).....: Ben Sun
Project Engineer

Approved by (name + signature).....: Sample Guan
Project Manager

Date of issue.....: June 24, 2020



Revision History

Revision	Issue Date	Revisions	Revised By
V0	June 24, 2020	Initial released Issue	Ben Sun

1. General Information

1.1. Description of Device (EUT)

Description : Gaming mouse

Model Number : A869RGB, A866, A867, A868, A869, A876, A883, A885, A888, A903, A904, A905, A906, A907, A908, H100, H200, H300, H400, H500, H600, H700, H800, H900, X100, X200, X300, X400, X500, X600, X700, X800, X900, J200, J300, J400, J500, J600, J700, J800, J900, X300GY, S100, S200, S300, S400, S500, S600, S700, S800, S900

Diff : There is no difference between the models except the appearance color. So all the test were performed on the model A869RGB.

Test Voltage : DC 5V from PC

EUT information : Input: DC 5V

Highest frequency : Less than 108MHz

Trademark : N/A

Software version : N/A

Hardware version : N/A

1.2. Accessories of Device (EUT)

Power Source : Power form PC

1.3. Tested Supporting System Details

No.	Description	Manufacturer	Model	Serial Number
1.	PC	ACER	ASPIRE M1830	PTSF90C00305005CAC3000
2.	USB Keyword	ACER	SK-9625	KBUSB1580500037E0100
3.	Printer	HP	HP1020	CNCJ410726
4.	Monitor	ACER	G205HV	SNID:10306738385
5.	TV	TCL	L32F1510BN	2400109888

1.4. Block Diagram of connection between EUT and simulators

For Test

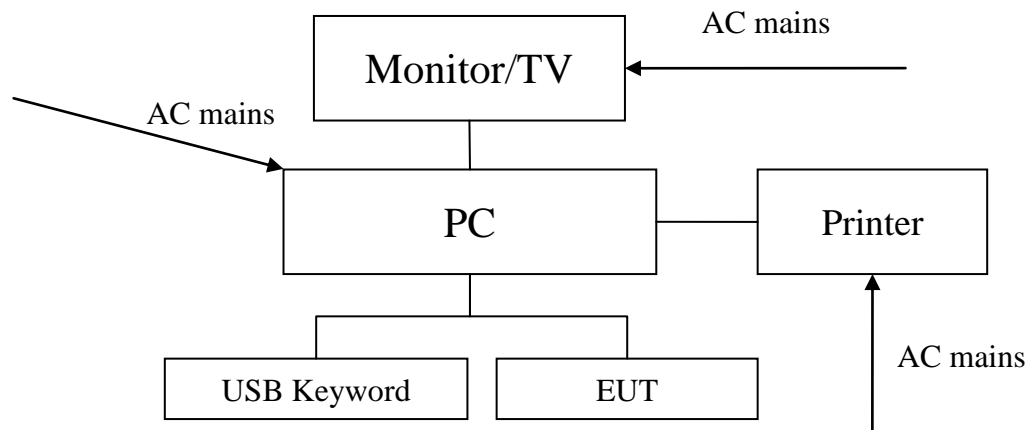

Signal Cable Description of the above Support Units					
No.	Port Name	Cable	Length	Shielded (Yes or No)	Detachable (Yes or No)
(a)	N/A	N/A	N/A	N/A	N/A

2. Summary Of Standards And Results

2.1. Description of Standards and Results

The EUT have been tested according to the applicable standards as referenced below:

EMISSION				
Description of Test Item	Standard	Limits	Results	
Radiated Emissions	EN 55032:2015	Annex A.2	P	
Radiated Emissions From FM Receivers	EN 55032:2015	Annex A.2	N/A	
Conducted Emissions From The AC Mains Power Ports	EN 55032:2015	Annex A.3	N/A	
Conducted Emissions From Asymmetric Mode	EN 55032:2015	Annex A.3	N/A	
Conducted Differential Voltage Emissions	EN 55032:2015	Annex A.3	N/A	
Harmonic current emissions	EN 61000-3-2:2014	Section 7	N/A	
Voltage fluctuations & flicker	EN 61000-3-3:2013	Section 5	N/A	
IMMUNITY (EN 55035:2017)				
Description of Test Item	Standard	Performance Criteria	Observation Criteria	Results
Electrostatic discharge (ESD)	IEC 61000-4-2:2008	B	A	P
Radio-frequency, Continuous radiated disturbance	IEC 61000-4-3:2006+ A1:2007 + A2:2010	A	A	P
Electrical fast transient (EFT)	IEC 61000-4-4:2012	B	N/A	N/A
Surge (Input a.c. power port)	IEC 61000-4-5:2014+ A1:2017	B	N/A	N/A
Surge (Telecommunication port)		B	N/A	N/A
Radio-frequency, Continuous conducted disturbance	IEC 61000-4-6:2013	A	N/A	N/A
Broadband impulsive conducted disturbances		A	N/A	N/A
Power frequency magnetic field	IEC 61000-4-8:2009	A	N/A	N/A
Voltage dips, >95% reduction	IEC 61000-4-11:2020	B	N/A	N/A
Voltage dips, 30% reduction		C	N/A	N/A
Voltage interruptions, >95% reduction		C	N/A	N/A

Note:

1. P is an abbreviation for Pass.
2. F is an abbreviation for Fail.
3. N/A is an abbreviation for Not Applicable.

2.2. Test Mode Description

For EMI Tests		
No.	Test Mode	Test Voltage
1.	Working	DC 5V from PC

2.3.Test Equipment List

For Conducted Disturbance At Mains Terminals Test Equipment:						
Item	Equipment	Manufacturer	Model No.	Serial No.	Last Cal.	Cal. Interval
1.	Test Receiver	Rohde & Schwarz	ESCI	101165	2019.09.05	1 Year
2.	L.I.S.N.#1	Schwarz beck	NSLK8126	8126466	2019.09.05	1 Year
3.	L.I.S.N.#2	ROHDE&SCHWARZ	ENV216	101043	2019.09.05	1 Year
4.	Pulse Limiter	Schwarz beck	9516F	9618	2019.09.05	1 Year

For Frequency Range 30MHz~1GHz Radiated Emission Test Equipment:						
Item	Equipment	Manufacturer	Model No.	Serial No.	Last Cal.	Cal. Interval
1	Test Receiver	Rohde&Schwarz	ESR	1316.3003K03-102082-Wa	2019.09.06	1 Year
3	Bilog Antenna	Schwarz beck	VULB 9168	9168-627	2019.09.07	2 Year

For Frequency Range above 1GHz Radiated Emission Test Equipment:						
Item	Equipment	Manufacturer	Model No.	Serial No.	Last Cal.	Cal. Interval
1	Spectrum analyzer	Rohde&Schwarz	FSV40-N	102137	2019.09.05	1 Year
2	Horn Antenna	Schwarz beck	BBHA 9120 D	2106	2019.09.07	2 Year
3	Amplifier	Agilent	8449B	3008A02664	2019.09.05	1 Year

For Harmonic Current Test & Voltage Fluctuations & Flicker Test Equipment:						
Item	Equipment	Manufacturer	Model No.	Serial No.	Last Cal.	Cal. Interval
1.	Harmonics Flicker Analyser	Voltech	PM6000	200006700495	2019.09.06	1 Year

For Electrostatic Discharge Test Equipment:						
Item	Equipment	Manufacturer	Model No.	Serial No.	Last Cal.	Cal. Interval
1.	ESD Tester	HAEFELY	PESD1610	H310546	2019.09.12	1 Year

For RF Field Strength Susceptibility Test Equipment:						
Item	Equipment	Manufacturer	Model No.	Serial No.	Last Cal.	Cal. Interval
1.	vector Signal Generator	Agilent	E4438C	US44271917	2019.09.06	1 Year
2.	Power meter	Agilent	E4419B	GB40202122	2019.09.06	1 Year
3.	Power Sensor	Agilent	E9300A	MY41496625s	2019.09.06	1 Year
4.	RF power Amplifier	OPHIR	5225R	1045	N/A	NCR
5.	RF power Amplifier	OPHIR	5273R	1018	N/A	NCR
6.	Antenna	SCHWARZBECK	STLP9128E-special	STLP9128Es#139	N/A	NCR
7.	Antenna	SCHWARZBECK	STLP9128E-special	STLP 9149#456	N/A	NCR

For Electrical Fast Transient/Burst Immunity, Surge, Power Frequency Magnetic Field Immunity, Voltage dips and interruptions test Equipment:						
Item	Equipment	Manufacturer	Model No.	Serial No.	Last Cal.	Cal. Interval
1.	Multifunctional Compact Immunity Test system	3ctest	CCS 600	ES0801655	2019.09.05	1 Year
2.	Surge & EFT Coupling Decoupling Network	3ctest	SEPN 3832T	ES0951601	2019.09.05	1 Year
3.	Voltage variation and PF magnetic field regulating device	3ctest	VMT2216S	ES0441601	2019.09.06	1 Year
4.	Capacitive Coupling Clamp	3ctest	CCC 100	EC0441660	2019.09.05	1 Year

For Injected currents susceptibility test Equipment:						
Item	Equipment	Manufacturer	Model No.	Serial No.	Last Cal.	Cal. Interval
1.	Conducted Immunity test System	SKET	CITS_150K230M	SK2019101001_CITS	2019.11.08	1 Year
2.	Fixed Coaxial Attenuator (6dB Attenuation)	CD	ATT-0675	120540086	2019.09.06	1 Year
3.	coupling-decoupling network (CDN)	CD	CDN M2/M3	2302	2019.09.06	1 Year
4.	Electromagnetic Injection Clamp (EMC-Clamp)	CD	EM-Clamp	0513A031201	2019.09.05	1 Year

2.4. Test Facility

Shenzhen Alpha Product Testing Co., Ltd.

Building i, No.2, Lixin Road, Fuyong Street, Bao'an District, 518103,
Shenzhen, Guangdong, China

2.5. Measurement Uncertainty

Test Item	Uncertainty	U_{cispr}
Uncertainty for Conduction emission test	2.74dB	3.8 dB
Uncertainty for Radiation Emission test (<1G)	3.77 dB (Distance: 3m Polarize: V)	5.2 dB
	3.80 dB (Distance: 3m Polarize: H)	
Uncertainty for Radiation Emission test (>1G)	4.13 dB (Distance: 3m Polarize: V)	5.2 dB
	4.16 dB (Distance: 3m Polarize: H)	
(95% confidence levels, k=2)		

3. Conducted Emissions At Mains Terminals Test

3.1. Test Limit

Frequency	Maximum RF Line Voltage	
	Quasi-Peak Level dB(μ V)	Average Level dB(μ V)
150kHz ~ 500kHz	66 ~ 56*	56 ~ 46*
500kHz ~ 5MHz	56	46
5MHz ~ 30MHz	60	50

- Notes:
1. Emission level=Read level + LISN factor-Preamp factor + Cable loss
 2. * Decreasing linearly with logarithm of frequency.
 3. The lower limit shall apply at the transition frequencies.

3.2. Block Diagram of Test Setup

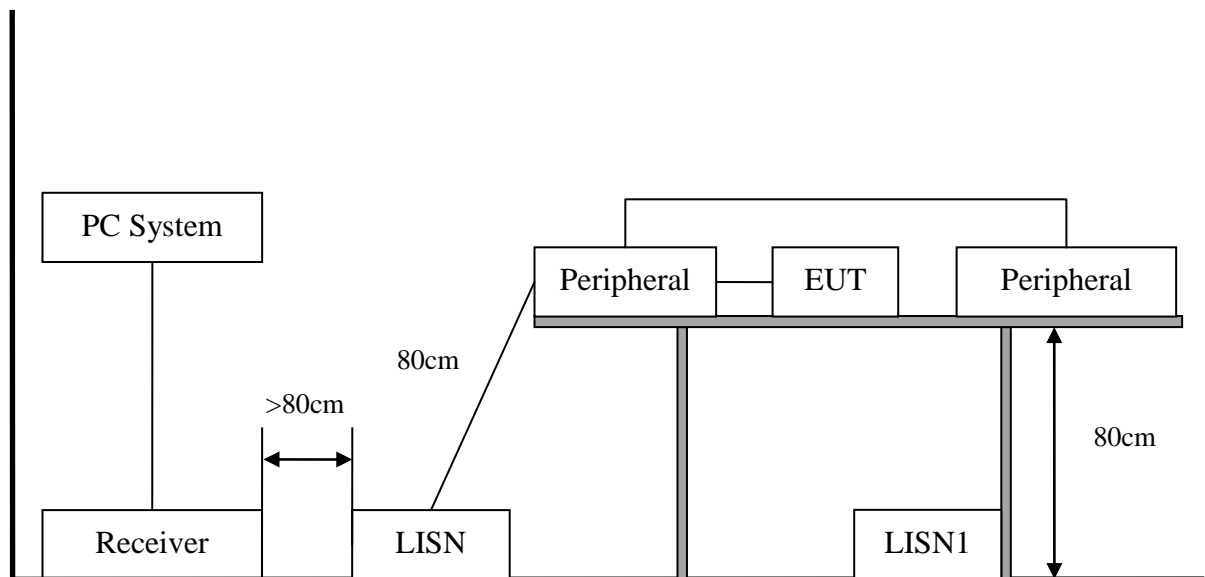

3.3. Configuration of EUT on Test

The following equipment are installed on conducted disturbance at mains terminals to meet the EN 55032 requirement and operating regulations in a manner which tends to maximize its emission characteristics in a normal application.

3.4. Operating Condition of EUT

- (1) Setup the EUT as shown as Section 3.2.
- (2) Turn on the power of all equipment.
- (3) Let the EUT work in test mode and 15 minutes before taking the test.

3.5. Test Procedure

- (1) The EUT was placed on a non-metallic table, 80cm above the ground plane. The EUT Power connected to the power mains through a line impedance stabilization network (L.I.S.N. 1#). This provided a 50-ohm coupling impedance for the EUT (Please refer to the block diagram of the test setup and photographs). The other peripheral devices power cord connected to the power mains through a line impedance stabilization network (L.I.S.N.#2). Both sides of power line were checked for maximum conducted interference. In order to find the maximum emission, the relative positions of equipments and all of the interface cables were changed according to EN 55032 on Conducted Disturbance at Mains Terminals test.
- (2) The frequency range from 150kHz to 30MHz is checked, the bandwidth of test receiver (R&S TEST RECEIVER ESCI) is set at 9kHz.
- (3) The test results are reported on Section 3.6.

3.6. Conducted Emissions at Mains Terminals Test Results

EUT	: Gaming mouse	Test Date	: N/A
M/N	: A869RGB	Temperature	: N/A
Test Engineer	: N/A	Humidity	: N/A
Test Voltage	: N/A	Pressure	: N/A
Test Mode	: N/A		
Test Results	: N/A		
Note: 1. Not applicable for equipment operated with PC, battery, or Power Supply.			

4. Radiated Emissions Test

4.1. Test Limit

Frequency MHz			Distance (Meters)	Field Strengths Limits dB(μ V)/m
30	~	230	3	40
230	~	1000	3	47
1000	~	3000	3	70(Peak) 50(Average)
3000	~	6000	3	74(Peak) 54(Average)

- Notes:
1. Emission level = Read level + Antenna Factor - Preamp Factor + Cable Loss
 2. The smaller limit shall apply at the cross point between two frequency bands.
 3. Distance is the distance in meters between the measuring instrument, antenna and the closest point of any part of the device or system.
 4. Frequency range of radiated measurements:

Highest frequency generated or used in the device or on which the device operates or tunes (MHz)	Upper frequency of measurement range (MHz)
Below 108	1000
108-500	2000
500-1000	5000
Above 1000	5th harmonic of the highest frequency or 6 GHz, whichever is lower.

4.2. Block Diagram of Test Setup

In Semi Anechoic Chamber (3m) Test Setup Diagram for 30MHz~1000MHz

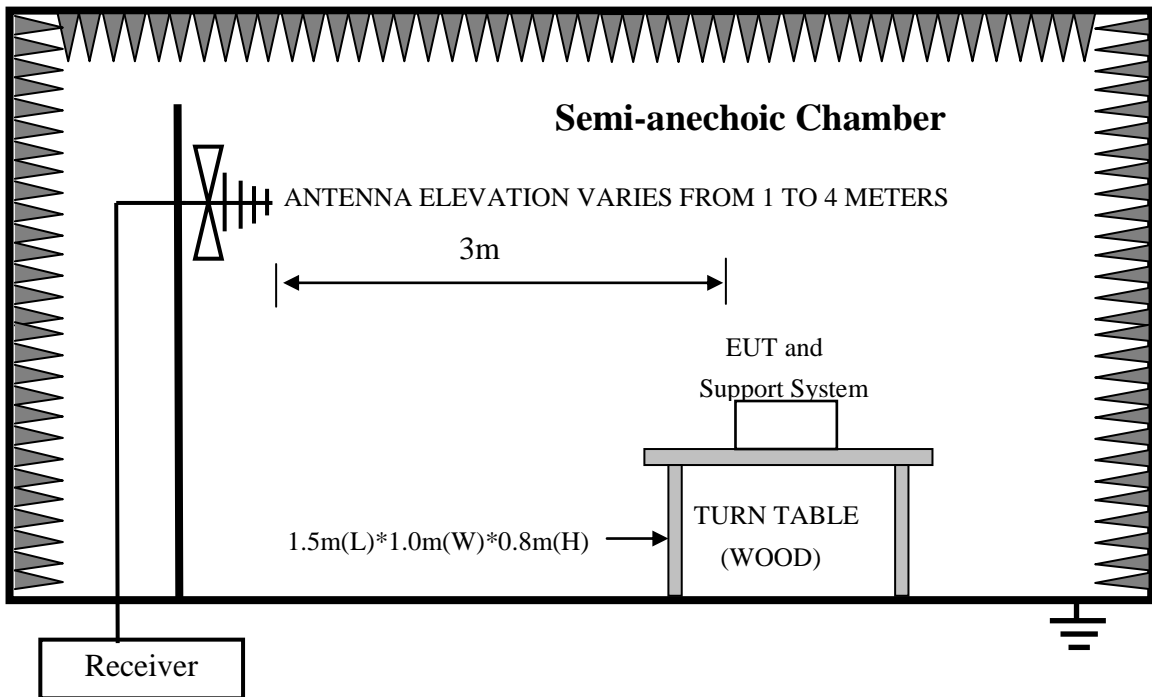

In Semi Anechoic Chamber (3m) Test Setup Diagram for Above 1GHz

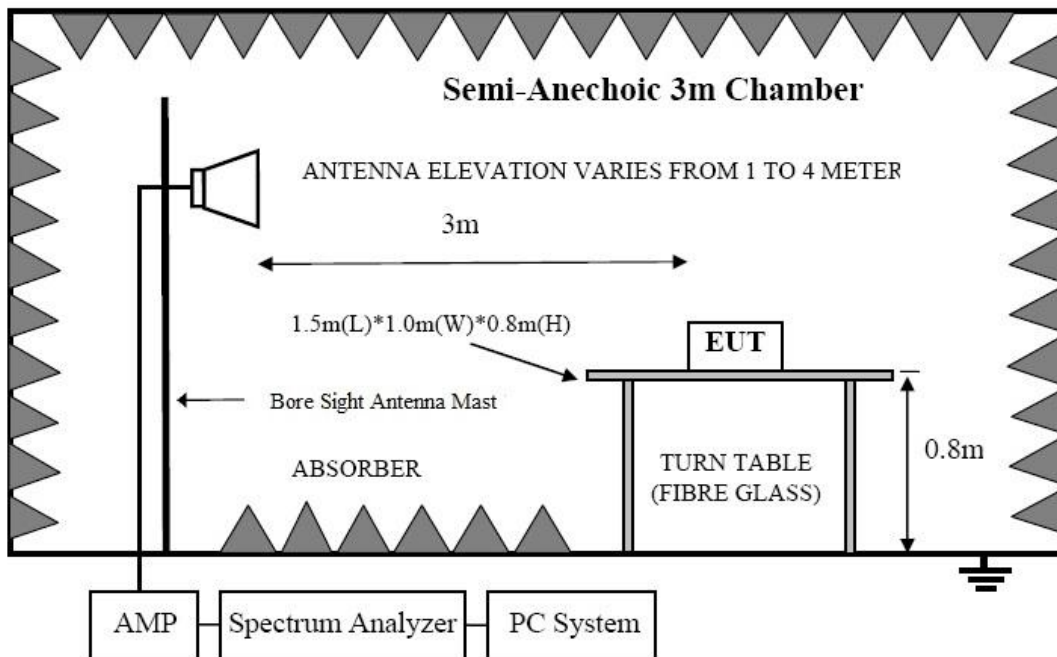

For 3m distance description:

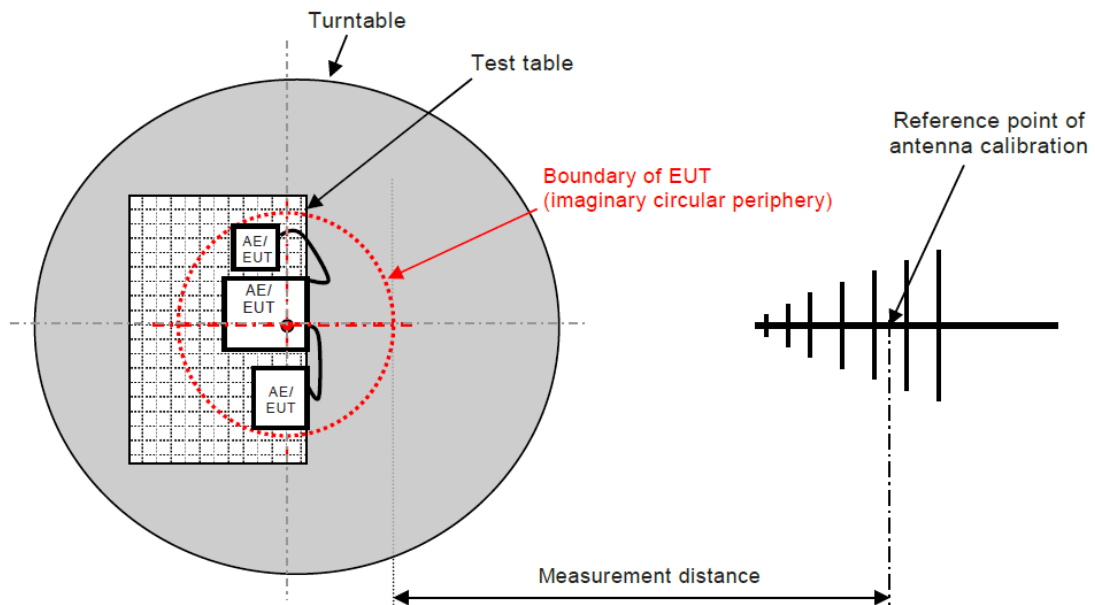

4.3. Configuration of EUT on Test

The following equipment are installed on Radiated Emission Test to meet the EN 55032 requirements and operating regulations in a manner that tends to maximize its emission characteristics in normal application.

4.4. Operating Condition of EUT

- (1) Setup the EUT as shown as Section 4.2.
- (2) Turn on the power of all equipment.
- (3) Let the EUT work in test mode and 15 minutes before taking the test.

4.5. Test Procedure

- (1) The EUT was placed on a non-metallic table, 80 cm above the ground plane inside a semi-anechoic chamber. An antenna was located 3m from the EUT on an adjustable mast. A pre-scan was first performed in order to find prominent radiated emissions. For final emissions measurements at each frequency of interest, the EUT were rotated and the antenna height was varied between 1m and 4m in order to maximize the emission. Measurements in both horizontal and vertical polarities were made and the data was recorded. In order to find the maximum emission, the relative positions of equipments and all the interface cables were changed according to EN 55032 on Radiated Disturbance test.
- (2) The frequency range from 30MHz to 1000MHz is checked, the bandwidth of test receiver (R&S TEST RECEIVER ESR) is set at 120kHz.
- (3) The resolution bandwidth of the R&S Spectrum Analyzer FSV40-N was set at 1MHz. (For above 1GHz)
- (4) The frequency range from 30MHz to 1000MHz was pre-scanned with a peak detector and all final readings of measurement from Test Receiver are Quasi-Peak values, all measurement distance is 3m in 3m semi anechoic chamber.
- (5) The frequency range from 1GHz to 6GHz was checked with peak and average detector, measurement distance is 3m in 3m chamber.
- (6) The test results are reported on Section 4.6.

4.6.Radiated Emissions Test Results

For below 1G radiated disturbance test result:	
EUT : Gaming mouse	Test Date : 2020.06.19
M/N : A869RGB	Temperature : 24°C
Test Engineer : Ben Sun	Humidity : 56%
Test Voltage : DC 5V from PC	Pressure : 101.3KPa
Test Mode : Working	
Test Results : PASS	
Note: 1. The test results are listed in next pages. 2. This mode is worst case mode, so this report only reflected the worst mode.	

Antenna polarity: Vertical

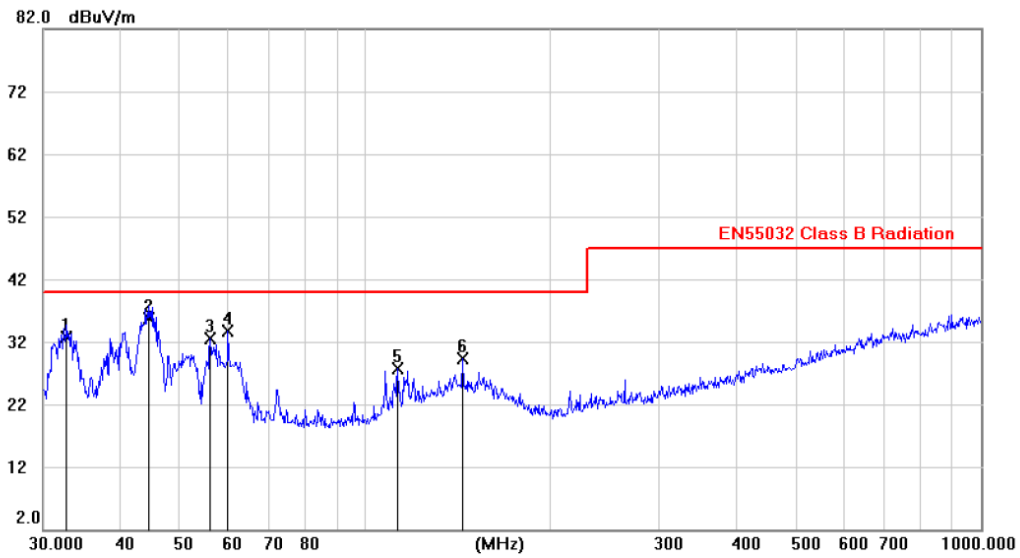

No.	Mk.	Freq.	Reading Level	Correct Factor	Measurement	Limit	Margin	Antenna Height	Table Degree	
		MHz	dBuV	dB	dBuV/m	dBuV/m	dB	cm	degree	Comment
1		32.7830	19.01	13.65	32.66	40.00	-7.34			QP
2	*	44.7120	21.57	14.14	35.71	40.00	-4.29			QP
3		56.0202	18.97	13.57	32.54	40.00	-7.46			peak
4		59.9849	20.41	13.25	33.66	40.00	-6.34			peak
5		112.9988	15.51	12.19	27.70	40.00	-12.30			peak
6		144.0312	14.74	14.61	29.35	40.00	-10.65			peak

Note:1. *:Maximum data; x:Over limit; !:over margin.

2.Measurement=Reading Level+Correct Factor; Correct Factor=Antenna Factor+Cable Loss.

Antenna polarity: Horizontal

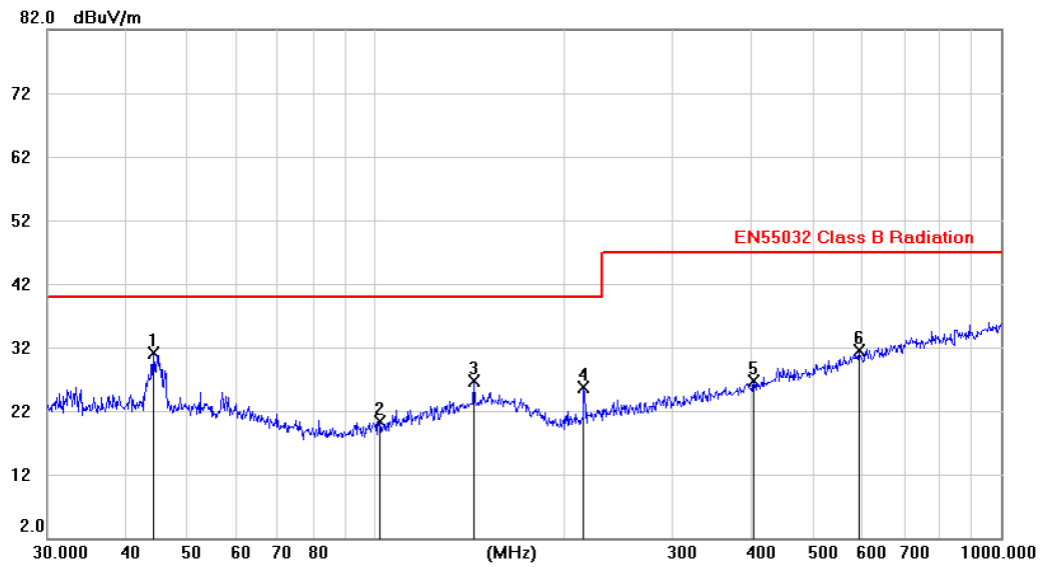

No.	Mk.	Freq.	Reading Level	Correct Factor	Measurement	Limit	Margin	Antenna Height	Table Degree	
		MHz	dBuV	dB	dBuV/m	dBuV/m	dB	cm	degree	Comment
1	*	44.3528	16.84	14.18	31.02	40.00	-8.98	peak		
2		101.9656	9.36	11.04	20.40	40.00	-19.60	peak		
3		143.9808	12.08	14.61	26.69	40.00	-13.31	peak		
4		216.0238	14.26	11.47	25.73	40.00	-14.27	peak		
5		402.5436	10.37	16.30	26.67	47.00	-20.33	peak		
6		592.4261	11.36	20.07	31.43	47.00	-15.57	peak		

Note:1. *:Maximum data; x:Over limit; !:over margin.

2.Measurement=Reading Level+Correct Factor; Correct Factor=Antenna Factor+Cable Loss.

For above 1G radiated emissions test result:

EUT	: Gaming mouse	Test Date	: N/A
M/N	: A869RGB	Temperature	: N/A
Test Engineer	: Ben Sun	Humidity	: N/A
Test Voltage	: N/A	Pressure	: N/A
Test Mode	: N/A		
Test Results	: N/A		
Note:	1. The highest frequency of the internal sources of the EUT is less than 108 MHz, the measurement shall only be made up to 1 GHz. So the frequency rang 1GHz-6GHz radiation test not applicable.		

5. Harmonic Current Test

5.1. Test Limit

For Class A equipment:

Harmonic order n	Maximum permissible harmonic current A
Odd harmonics	
3	2,30
5	1,14
7	0,77
9	0,40
11	0,33
13	0,21
$15 \leq n \leq 39$	$0,15 \frac{15}{n}$
Even harmonics	
2	1,08
4	0,43
6	0,30
$8 \leq n \leq 40$	$0,23 \frac{8}{n}$

for Class B equipment:

The harmonics of the input current shall not exceed the values given in Class A equipment limit multiplied by a factor of 1,5.

5.2. Block Diagram of Test Setup

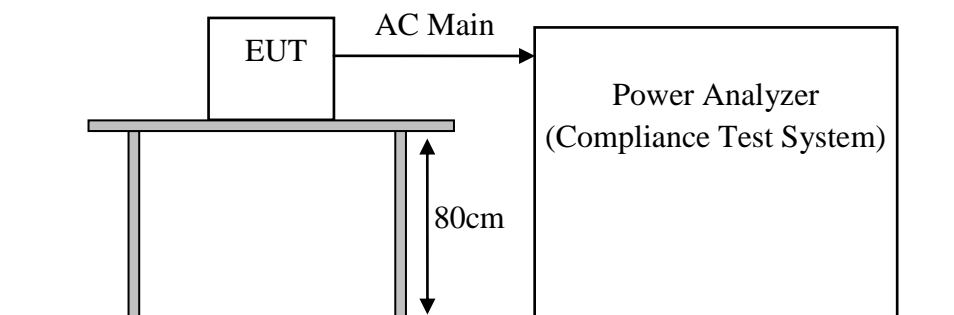

5.3. Configuration of EUT on Test

The following equipment are installed on Harmonic Current Test to meet the EN61000-3-2 requirements and operating regulations in a manner that tends to maximize its emission characteristics in normal application.

5.4. Operating Condition of EUT

- (1) Setup the EUT as shown as Section 5.2.
- (2) Turn on the power of all equipment.
- (3) Let the EUT work in test mode and 15 minutes before taking the test.

5.5. Test Procedure

- (1) The EUT was placed on the top of a wooden table 0.8 meters above the ground and operated to produce the maximum harmonic components under normal operating conditions for each successive harmonic component in turn. The correspondent test program of test instrument to measure the current harmonics emanated from EUT is chosen. The measure time shall be not less than the necessary for the EUT to be exercised.
- (2) The test results are reported on Section 5.6.

5.6.Harmonic Current Test Results

EUT : Gaming mouse	Test Date : N/A
M/N : A869RGB	Temperature : N/A
Test Engineer : N/A	Humidity : N/A
Test Voltage : N/A	Pressure : N/A
Test Mode : N/A	
Test Results : N/A	
Note: Not applicable for equipment operated with PC, battery, or Power Supply.	

6. Voltage Fluctuations & Flicker Test

6.1. Test Limit

Test Item	Limit	Note
P_{st}	1.0	P_{st} means Short-term flicker indicator
P_{lt}	0.65	P_{lt} means long-term flicker indicator
T_{dt}	0.2	T_{dt} means maximum time that dt exceeds 3%
$d_{max}(\%)$	4%	d_{max} means maximum relative voltage change.
$d_c(\%)$	3.3%	d_c means relative steady-state voltage change.

6.2. Block Diagram of Test Setup

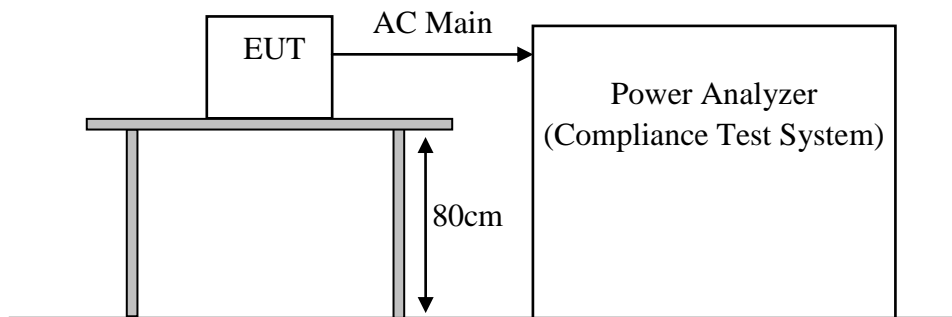

6.3. Configuration of EUT on Test

The following equipment are installed on Voltage Fluctuation and Flicker Test to meet the EN61000-3-3 requirements and operating regulations in a manner that tends to maximize its emission characteristics in normal application.

6.4. Operating Condition of EUT

- (1) Setup the EUT as shown as Section 6.2.
- (2) Turn on the power of all equipment.
- (3) Let the EUT work in test mode and 15 minutes before taking the test.

6.5. Test Procedure

- (1) The EUT was placed on the top of a wooden table 0.8 meters above the ground and operated to produce the most unfavorable sequence of voltage changes under normal conditions During the flick measurement; the measure time shall include that part of whole operation changes. The observation period for short-term flicker indicator is 10 minutes and the observation period for long-term flicker indicator is 2 hours.
- (2) The test results are reported on Section 6.6.

6.6. Voltage Fluctuation and Flicker Test Results

EUT : Gaming mouse	Test Date : N/A
M/N : N/A	Temperature : N/A
Test Engineer : N/A	Humidity : N/A
Test Voltage : N/A	Pressure : N/A
Test Mode : N/A	
Test Results : N/A	
Note: Not applicable for equipment operated with PC, battery, or Power Supply.	

7. Immunity General performance criteria

Performance Level

When assessing the impact of a disturbance on a function, the assessment should take into consideration the function's performance prior to the application of the disturbance and only identify as failures those changes in performance that are a result of the disturbance.

Performance criterion A

The equipment shall continue to operate as intended without operator intervention. No degradation of performance, loss of function or change of operating state is allowed below a performance level specified by the manufacturer when the equipment is used as intended. The performance level may be replaced by a permissible loss of performance. If the minimum performance level or the permissible performance loss is not specified by the manufacturer, then either of these may be derived from the product description and documentation, and by what the user may reasonably expect from the equipment if used as intended.

Performance criterion B

During the application of the disturbance, degradation of performance is allowed. However, no unintended change of actual operating state or stored data is allowed to persist after the test.

After the test, the equipment shall continue to operate as intended without operator intervention; no degradation of performance or loss of function is allowed, below a performance level specified by the manufacturer, when the equipment is used as intended. The performance level may be replaced by a permissible loss of performance.

If the minimum performance level (or the permissible performance loss), or recovery time, is not specified by the manufacturer, then either of these may be derived from the product description and documentation, and by what the user may reasonably expect from the equipment if used as intended.

Performance criterion C

Loss of function is allowed, provided the function is self-recoverable, or can be restored by the operation of the controls by the user in accordance with the manufacturer's instructions. A reboot or re-start operation is allowed.

Information stored in non-volatile memory, or protected by a battery backup, shall not be lost.

8. Electrostatic Discharge Test

8.1. Electrostatic Discharge Test Limits

Test Type	Test Level	Performance Criterion
Air Discharge	8KV	B
Contact Discharge	4KV	B

Notes: 1. Test set-up reference IEC 61000-4-2:2008

8.2. Block Diagram of Test Setup

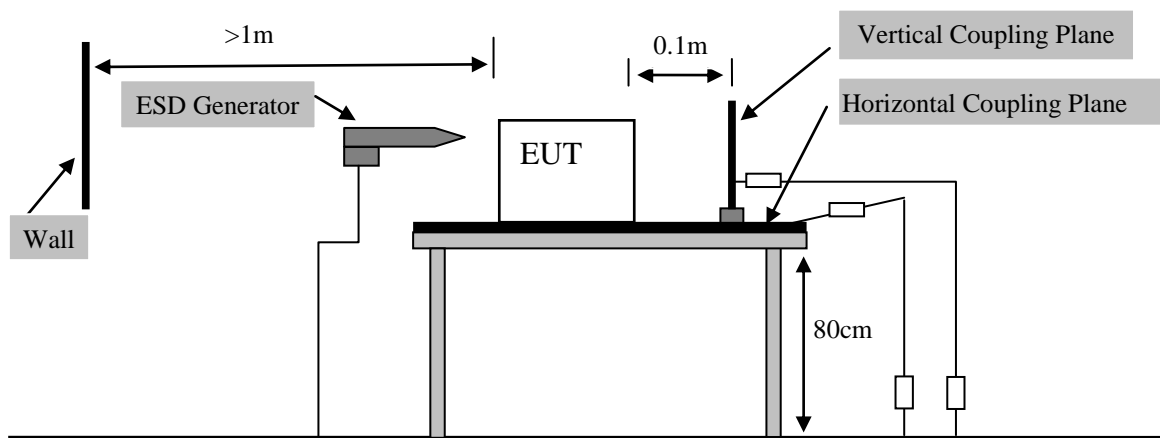

8.3. Configuration of EUT on Test

The following equipment are installed on Electrostatic Discharge Test to meet the IEC 61000-4-2 requirements and operating regulations in a manner that tends to maximize its emission characteristics in normal application.

8.4. Operating Condition of EUT

- (1) Setup the EUT as shown as Section 8.2.
- (2) Turn on the power of all equipment.
- (3) Let the EUT work in test mode and 15 minutes before taking the test.

8.5. Test Procedure

- (1) Air Discharge:

The test was applied on non-conductive surfaces of EUT. The round discharge tip of the discharge electrode was approached as fast as possible to touch the EUT. After each discharge, the discharge electrode was removed from the EUT. The generator was re-triggered for a new single discharge and repeated 20 times (10 with positive and 10

negative with positive) for each pre-selected test point. This procedure was repeated until all the air discharge completed.

(2) Contact Discharge:

All the procedure was same as Section 8.5(1). Except that for the time interval between successive single discharges an initial value of 1 s is recommended. Longer intervals may be necessary to determine whether a system failure has occurred.

(3) Indirect discharge for horizontal coupling plane:

At least 20 single discharges (10 with positive and 10 negative with positive) were applied to the horizontal coupling plane, at points on each side of the EUT. The discharge electrode positions vertically at a distance of 0.1m from the EUT and with the discharge electrode touching the coupling plane.

(4) Indirect discharge for vertical coupling plane:

At least 20 single discharge (10 with positive and 10 negative with positive) were applied to the center of one vertical edge of the coupling plane. The coupling plane, of dimensions 0.5m X 0.5m, was placed parallel to, and positioned at a distance of 0.1m from the EUT. Discharges were applied to the coupling plane, with this plane in sufficient different positions that the four faces of the EUT are completely illuminated.

8.6. Electrostatic Discharge Test Results

EUT	: Gaming mouse	Test Date	: 2020.06.23	
M/N	: A869RGB	Temperature	: 24°C	
Test Engineer	: Ben Sun	Humidity	: 56%	
Test Voltage	DC 5V from PC	Pressure	: 101.3KPa	
Test Mode	: Working			
Test Results	: PASS			
Discharge Voltage (kV)	Type Of Discharge	Dischargeable Points	Performance	
			Required	Observation
±2	Contact	N/A	B	N/A
±4	Contact	N/A	B	N/A
±2	Air	1, 2, 3	B	A
±4	Air	1, 2, 3	B	A
±8	Air	1, 2, 3	B	A
±4	HCP-Bottom	Edge of the HCP	B	A
±4	VCP-Front	Center of the VCP	B	A
±4	VCP-Left	Center of the VCP	B	A
±4	VCP-Back	Center of the VCP	B	A
±4	VCP-Right	Center of the VCP	B	A
Discharge Points Description				
<u>1</u>	Button	<u>4</u>		
<u>2</u>	Port	<u>5</u>		
<u>3</u>	Gap	<u>6</u>		
Note:	<p>1. For the time interval between successive single discharges an initial value of one second.</p> <p>2. For Air Discharge each Point Positive 10 times and negative 10 times discharge.</p> <p>3. Class A is no function loss.</p> <p>4. EUT does not contain metal contact points, not need to contact discharge measurement</p>			

9. RF Field Strength Susceptibility Test

9.1. Test Level

Test Specifications	Test Level	Performance Criterion
80MHz-1000MHz	3V/m (r.m.s.)	A
1800(± 1%)MHz		A
2600(± 1%)MHz		A
3500(± 1%)MHz		A
5000(± 1%)MHz		A

Notes: 1. Test set-up reference IEC 61000-4-3:2006 + A1:2007 + A2:2010

9.2. Block Diagram of Test Setup

For frequency from 80MHz to 1000MHz

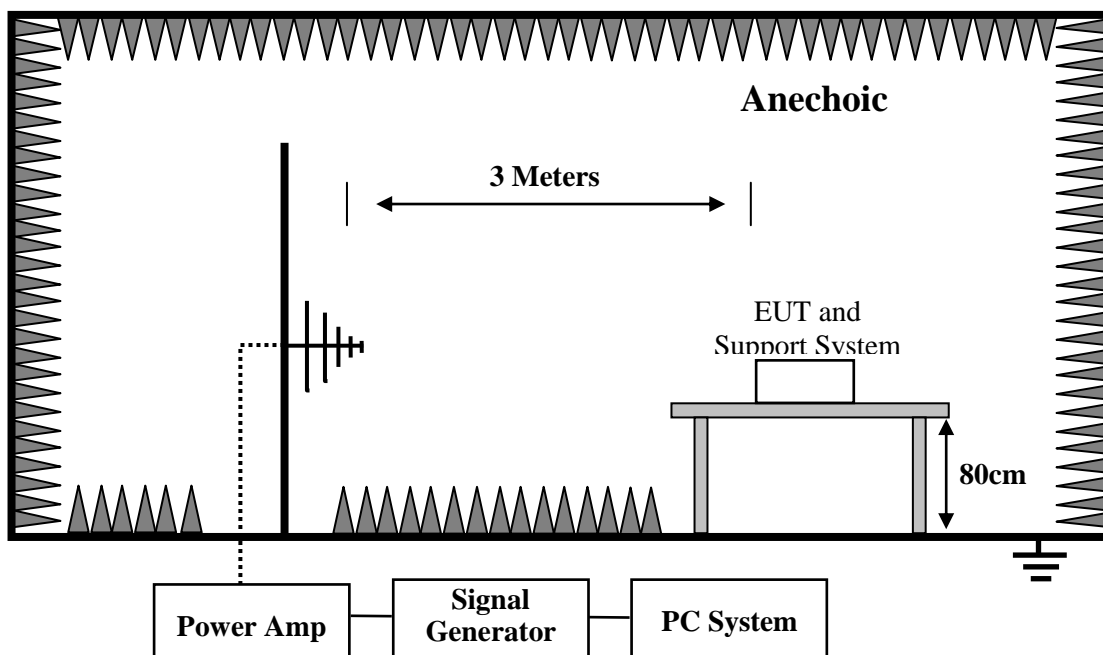

For frequency above 1000MHz

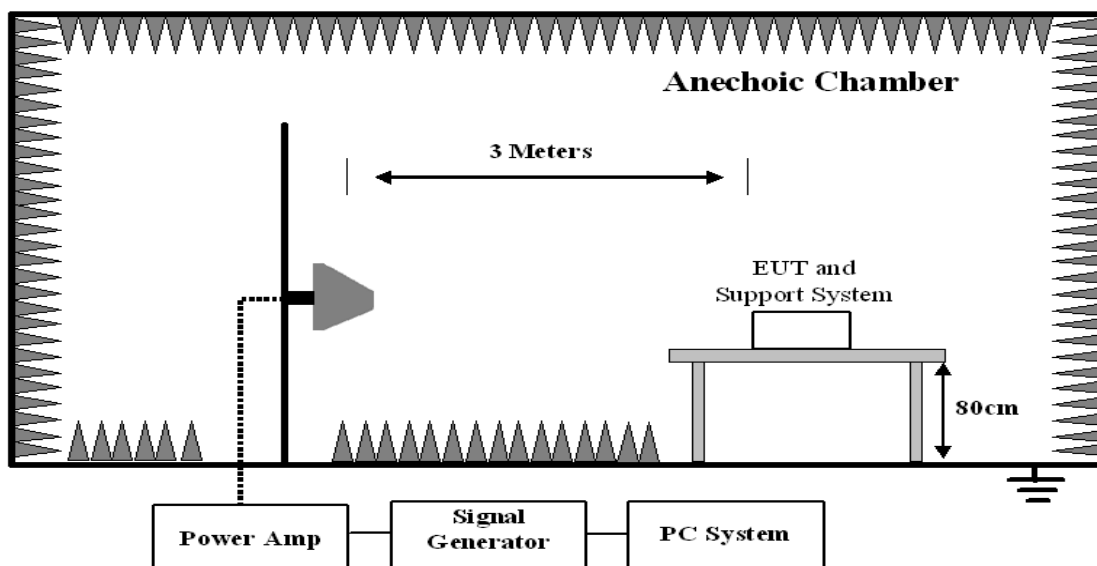

9.3. Configuration of EUT on Test

The following equipment are installed on RF Field Strength Susceptibility Test to meet the IEC 61000-4-3 requirements and operating regulations in a manner that tends to maximize its emission characteristics in normal application.

9.4. Operating Condition of EUT

- (1) Setup the EUT as shown as Section 9.2.
- (2) Turn on the power of all equipment.
- (3) Let the EUT work in test mode and 15 minutes before taking the test.

9.5. Test Procedure

- (1) Testing was performed in a Fully anechoic chamber as recommended by IEC 61000-4-3. The EUT was placed on an 80 cm high non-conductive table located in the area of field uniformity. The radiating antenna was placed 3m in front of the EUT and Support system, and dwell time of the radiated interference was controlled by an automated, computer-controlled system.
- (2) The signal source was stepped through the applicable frequency range at a rate no faster than 1% of the fundamental. The signal was amplitude modulated 80% over the frequency range 80 MHz to 1GHz at a level of 3 V/m. The dwell time was set at 1 s. Field presence was monitored during testing via a field probe placed in close proximity to the EUT.
- (3) Throughout testing, the EUT was closely monitored for signs of susceptibility. The test was performed with the antennae oriented in both a horizontal and vertical polarization.

9.6.RF Field Strength Susceptibility Test Results

EUT	: Gaming mouse	Test Date	: 2020.06.23
M/N	: A869RGB	Temperature	: 24°C
Test Engineer	: Ben Sun	Humidity	: 56%
Test Voltage	DC 5V from PC	Pressure	: 101.3KPa
Test Mode	: Working		
Test Results	: PASS		
Note	: The test results are listed in next pages		

Modulation:	<input checked="" type="checkbox"/> AM	<input type="checkbox"/> Pulse	<input type="checkbox"/> none	1 kHz	80%
Frequency Range	80 MHz -1000MHz				
Field strength	3V/m				
Steps	1%				
	Horizontal		Vertical		Result
	Required	Observation	Required	Observation	(Pass / Fail)
Front	A	A	A	A	Pass
Right	A	A	A	A	Pass
Rear	A	A	A	A	Pass
Left	A	A	A	A	Pass
Remark: Class A is no function loss					

Modulation:	<input checked="" type="checkbox"/> AM	<input type="checkbox"/> Pulse	<input type="checkbox"/> none	1 kHz	80%
Frequency Range	1800($\pm 1\%$) MHz				
Field strength	3V/m				
Steps	spot test				
	Horizontal		Vertical		Result
	Required	Observation	Required	Observation	(Pass / Fail)
Front	A	A	A	A	Pass
Right	A	A	A	A	Pass
Rear	A	A	A	A	Pass
Left	A	A	A	A	Pass
Remark: Class A is no function loss					

Modulation:	<input checked="" type="checkbox"/> AM	<input type="checkbox"/> Pulse	<input type="checkbox"/> none	1 kHz	80%
Frequency Range	2600($\pm 1\%$) MHz				
Field strength	3V/m				
Steps	spot test				
	Horizontal		Vertical		Result
	Required	Observation	Required	Observation	(Pass / Fail)
Front	A	A	A	A	Pass
Right	A	A	A	A	Pass
Rear	A	A	A	A	Pass
Left	A	A	A	A	Pass
Remark: Class A is no function loss					

Modulation: <input checked="" type="checkbox"/> AM <input type="checkbox"/> Pulse <input type="checkbox"/> none 1 kHz 80%					
Frequency Range	3500($\pm 1\%$) MHz				
Field strength	3V/m				
Steps	spot test				
	Horizontal		Vertical		Result
	Required	Observation	Required	Observation	(Pass / Fail)
Front	A	A	A	A	Pass
Right	A	A	A	A	Pass
Rear	A	A	A	A	Pass
Left	A	A	A	A	Pass
Remark: Class A is no function loss					

Modulation: <input checked="" type="checkbox"/> AM <input type="checkbox"/> Pulse <input type="checkbox"/> none 1 kHz 80%					
Frequency Range	5000($\pm 1\%$) MHz				
Field strength	3V/m				
Steps	spot test				
	Horizontal		Vertical		Result
	Required	Observation	Required	Observation	(Pass / Fail)
Front	A	A	A	A	Pass
Right	A	A	A	A	Pass
Rear	A	A	A	A	Pass
Left	A	A	A	A	Pass
Remark: Class A is no function loss					

10. Electrical Fast Transient/Burst Immunity Test

10.1. Test Level

For AC mains power ports		
Test Specifications	Test Level	Performance Criterion
Tr/Th Repetition: 5/50ns Frequency: 5kHz	1KV	B
For DC network power ports and analogue/digital data ports		
Test Specifications	Test Level	Performance Criterion
Tr/Th Repetition: 5/50ns Frequency: 5kHz	0.5KV	B

Notes: 1. Test set-up reference IEC 61000-4-4:2012

10.2. Block Diagram of Test Setup

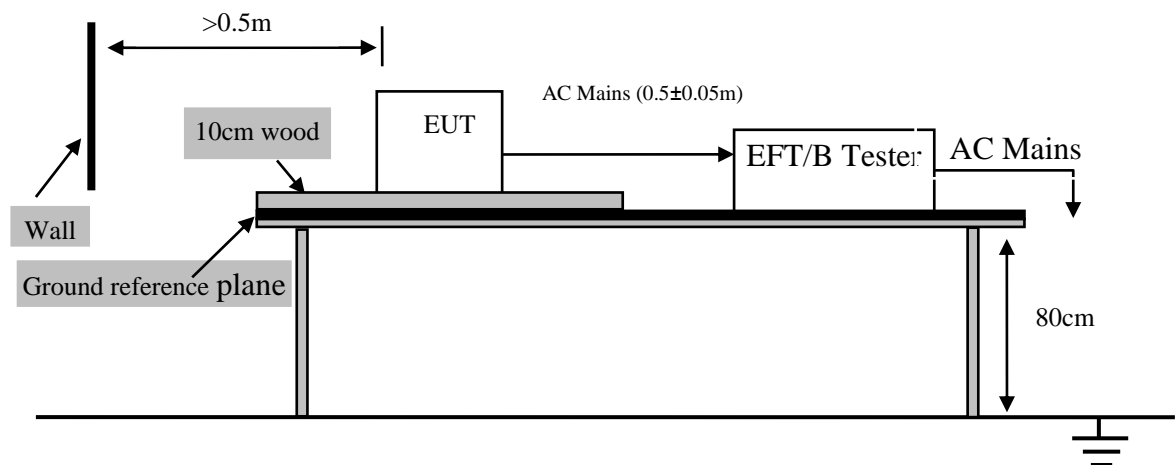

10.3. Configuration of EUT on Test

The following equipment are installed on Electrical Fast Transient/Burst immunity Test to meet the IEC 61000-4-4 requirements and operating regulations in a manner that tends to maximize its emission characteristics in normal application.

10.4. Operating Condition of EUT

- (1) Setup the EUT as shown as Section 10.2.
- (2) Turn on the power of all equipment.
- (3) Let the EUT work in test mode and 15 minutes before taking the test.

10.5. Test Procedure

The EUT and its simulators were placed on the ground reference plane and were insulated from it by a wood support 0.1m + 0.01m thick. The ground reference plane was 1m*1m metallic sheet with 0.65mm minimum thickness. This reference ground plane was project

(1) beyond the EUT by at least 0.1m on all sides and the minimum distance between EUT and all other conductive structure, except the ground plane was more than 0.5m. All cables to the EUT was placed on the wood support, cables not subject to EFT/B was routed as far as possible from the cable under test to minimize the coupling between the cables.

10.6.1. For input and AC power ports:

The EUT was connected to the power mains by using a coupling device that couples the EFT interference signal to AC power lines. Both positive transients and negative transients of test voltage were applied during compliance test and the duration of the test can't less than 1min.

10.6.2. For signal lines and control lines ports:

It's unnecessary to test.

10.6.3. For DC input and DC output power ports:

It's unnecessary to test.

10.6.Electrical Fast Transient/Burst immunity Test Results

EUT	: Gaming mouse	Test Date	: N/A
M/N	: A869RGB	Temperature	: N/A
Test Engineer	: N/A	Humidity	: N/A
Test Voltage	: N/A	Pressure	: N/A
Test Mode	: N/A		
Test Results	: N/A		
Note: 1. Not applicable for equipment operated with PC, battery, or Power Supply.			

11. Surge Test

11.1. Test Level

For AC mains power ports

Test Specifications	Test Level	Performance Criterion
Tr/Th Repetition: 1,2/50 (8/20)ns Between line and line	1 KV	B
Tr/Th Repetition: 1,2/50 (8/20)ns Between line and earth (ground)	2 KV	B

For DC network power ports

Test Specifications	Test Level	Performance Criterion
Tr/Th Repetition: 1,2/50 (8/20)ns Line to reference ground for each individual line	0.5 KV	B

For analogue/digital data ports

Test Specifications	Test Level	Performance Criterion
Tr/Th Repetition: 10/700 (5/320)ns unshielded symmetrical: lines to ground Apply where primary protection is intended	1 KV/4KV ^{a b}	C
Tr/Th Repetition: 10/700 (5/320)ns unshielded symmetrical: lines to ground Apply where primary protection is not intended	1 KV ^b	C
Tr/Th Repetition: 1,2/50 (8/20)ns coaxial or shielded: shield to ground	0.5KV ^c	B

- Notes:
1. Test set-up reference IEC 61000-4-5:2014+A1:2017
 2. ^a is surges are applied with primary protection fitted. Where possible, use the actual primary protector intended to be used in the installation.
 3. ^b is Where the surge coupling network for the 10/700 (5/320) μ s waveform affects the functioning of high speed data ports, the test shall be carried out using a 1,2/50 (8/20) μ s waveform and appropriate coupling network.
 4. ^a is Surges are applicable to ports which satisfy all the following conditions:
 - may connect directly to cables that leave the building structure,
 - defined as an antenna port, a wired network port, or a broadcast receiver tuner port see the standard EN 55035 section 3.

Typical ports covered include xDSL, PSTN, CATV, antenna and similar. Excluded ports are LAN and similar.

11.2. Block Diagram of Test Setup

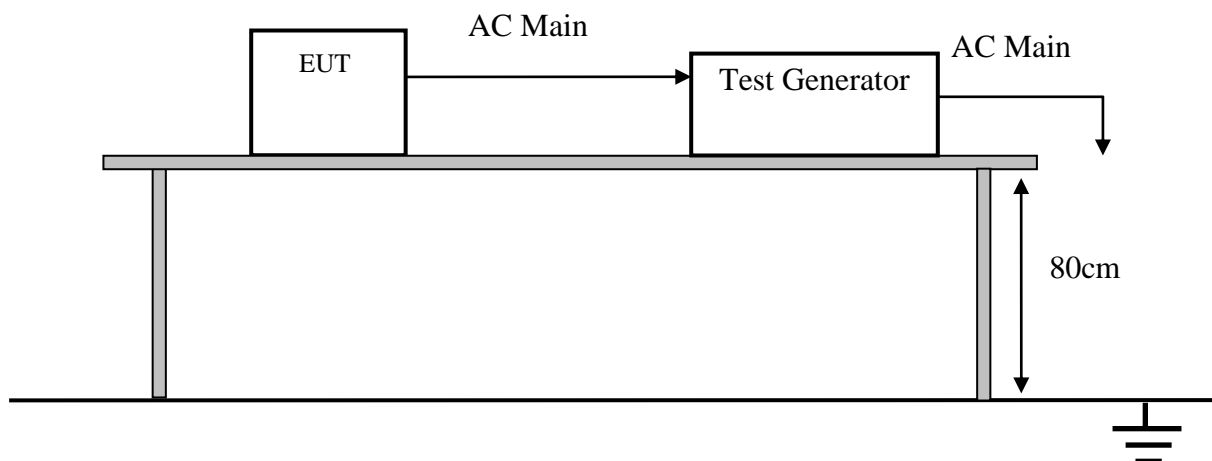

11.3. Configuration of EUT on Test

The following equipment are installed on Surge Test to meet the IEC 61000-4-5 requirements and operating regulations in a manner that tends to maximize its emission characteristics in normal application.

11.4. Operating Condition of EUT

- (1) Setup the EUT as shown as Section 11.2.
- (2) Turn on the power of all equipment.
- (3) Let the EUT work in test mode and 15 minutes before taking the test.

11.5. Test Procedure

- (1) For line-to-line coupling mode, provide a 1kV 1.2/50us voltage surge (at open-circuit condition) and 8/20us current surge to EUT selected points, and for active line / neutral lines to ground are same except test level is 2kV.
- (2) At least 5 positive and 5 negative (polarity) tests with a maximum 1/min repetition rate are applied during test.
- (3) Different phase angles are done individually.
- (4) Record the EUT operating situation during compliance test and decide the EUT immunity criterion for above each test.

11.6.Surge Test Results

EUT	: Gaming mouse	Test Date	: N/A
M/N	: A869RGB	Temperature	: N/A
Test Engineer	: N/A	Humidity	: N/A
Test Voltage	: N/A	Pressure	: N/A
Test Mode	: N/A		
Test Results	: N/A		
Note: Not applicable for equipment operated with PC, battery, or Power Supply.			

12. Injected Currents Susceptibility Test

12.1. Test Level

Test Specifications	Test Level	Performance Criterion
0,15 to 10MHz	3 V	A
10 to 30MHz	3 to 1 V	
30 to 80MHz	1 V	

Notes: 1. Test set-up reference IEC 61000-4-6:2013

12.2. Block Diagram of Test Setup

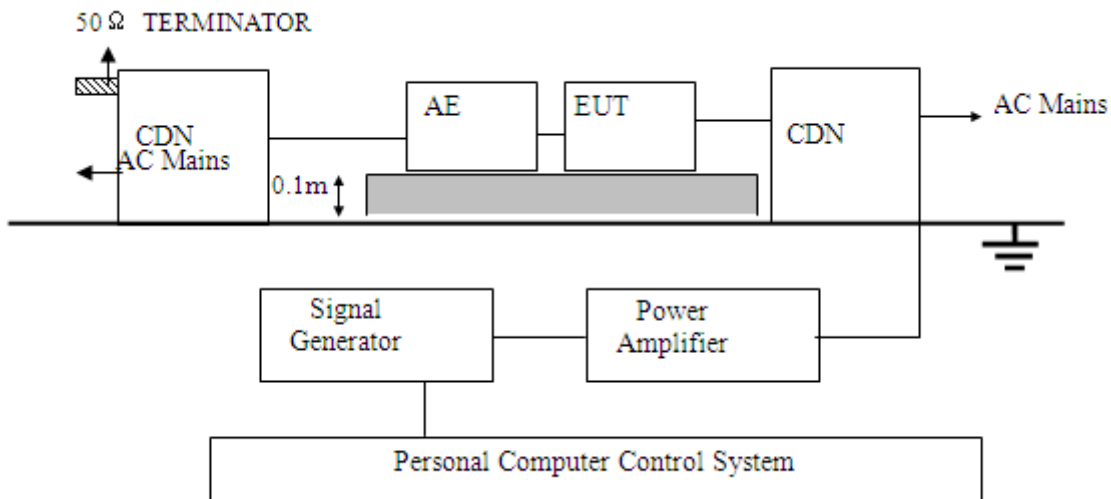

12.3. Configuration of EUT on Test

The following equipment are installed on Injected currents susceptibility Test to meet the IEC 61000-4-6 requirements and operating regulations in a manner that tends to maximize its emission characteristics in normal application.

12.4. Operating Condition of EUT

- (1) Setup the EUT as shown as Section 12.2.
- (2) Turn on the power of all equipment.
- (3) Let the EUT work in test mode and 15 minutes before taking the test.

12.5. Test Procedure

- (1) Let the EUT work in test mode and test it.
The EUT are placed on an insulating support 0.1m high above a ground reference plane.
- (2) CDN (coupling and decoupling device) is placed on the ground plane about 0.3m from EUT. Cables between CDN and EUT are as short as possible, and their height above the ground reference plane shall be between 10 and 30 mm (where possible).
- (3) The disturbance signal described below is injected to EUT through CDN.
- (4) The EUT operates within its operational mode(s) under intended climatic conditions after power on.
- (5) The frequency range is swept from 0.150MHz to 80MHz using 3V signal level, and with the disturbance signal 80% amplitude modulated with a 1kHz sine wave.
The rate of sweep shall not exceed $1.5 \cdot 10^{-3}$ decades/s. Where the frequency is swept
- (6) incrementally, the step size shall not exceed 1% of the start and thereafter 1% of the preceding frequency value.
- (7) Recording the EUT operating situation during compliance testing and decide the EUT immunity criterion.

12.6. Injected currents susceptibility Test Results

EUT : Gaming mouse	Test Date : N/A
M/N : A869RGB	Temperature : N/A
Test Engineer : N/A	Humidity : N/A
Test Voltage : N/A	Pressure : N/A
Test Mode : N/A	
Test Results : N/A	
Note: Not applicable for equipment operated with PC, battery, or Power Supply.	

13. Magnetic Field Immunity Test

13.1. Test Level

Test Specifications	Test Level	Performance Criterion
50 or 60 Hz	1 A/m	A

- Notes:
1. Test set-up reference IEC 61000-4-8:2009
 2. This test applicable only to equipment containing devices intrinsically susceptible to magnetic fields, such as CRT monitors, Hall effect elements, electro-dynamic microphones, magnetic field sensors or audio frequency transformers. Refer to D.3.2 for determining the test level when the EUT contains a CRT display.

13.2. Block Diagram of Test Setup

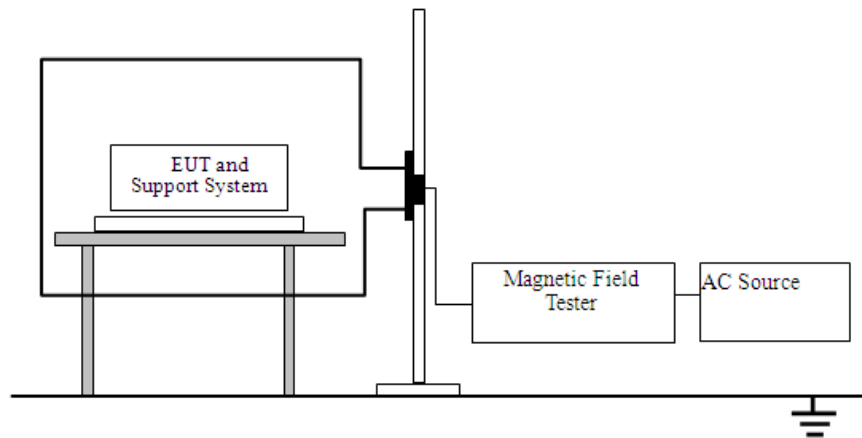

13.3. Configuration of EUT on Test

The following equipment are installed on Magnetic field immunity Test to meet the IEC 61000-4-8 requirements and operating regulations in a manner that tends to maximize its emission characteristics in normal application.

13.4. Operating Condition of EUT

- (1) Setup the EUT as shown as Section 13.2.
- (2) Turn on the power of all equipment.
- (3) Let the EUT work in test mode and 15 minutes before taking the test.

13.5. Test Procedure

- The EUT was subjected to the test magnetic field by using the induction coil of standard
- (1) dimensions (1m*1m) and shown in Section 13.2. The induction coil was then rotated by 90° in order to expose the EUT to the test field with different orientations.

13.6.Magnetic field immunity Test Results

EUT : Gaming mouse	Test Date : N/A
M/N : A869RGB	Temperature : N/A
Test Engineer : N/A	Humidity : N/A
Test Voltage : N/A	Pressure : N/A
Test Mode : N/A	
Test Results : N/A	
Note: The EUT not containing devices susceptible to magnetic fields, and Power-frequency magnetic field test applicable only to EUT containing devices susceptible to magnetic fields, so the test not applicable.	

14. Voltage Dips and Interruptions Test

14.1. Test Level

Test Level %U _T	Voltage dip and short interruptions %U _T	Performance Criterion	Duration (in period)
< 5	100	C	250
< 5	100	B	0.5
70	30	C	25

Notes: 1. Test set-up reference IEC 61000-4-11:2020

14.2. Block Diagram of Test Setup

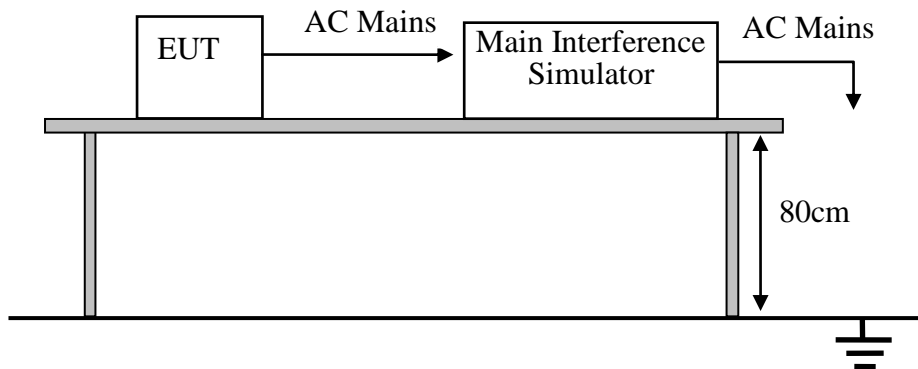

14.3. Configuration of EUT on Test

The following equipment are installed on Voltage dips and interruptions Test to meet the IEC 61000-4-11 requirements and operating regulations in a manner that tends to maximize its emission characteristics in normal application.

14.4. Operating Condition of EUT

- (1) Setup the EUT as shown as Section 14.2.
- (2) Turn on the power of all equipment.
- (3) Let the EUT work in test mode and 15 minutes before taking the test.

14.5. Test Procedure

- (1) The interruption is introduced at selected phase angles with specified duration.
- (2) Record any degradation of performance.

14.6.Voltage dips and interruptions Test Results

EUT	: Gaming mouse	Test Date	: N/A
M/N	: A869RGB	Temperature	: N/A
Test Engineer	: N/A	Humidity	: N/A
Test Voltage	: N/A	Pressure	: N/A
Test Mode	: N/A		
Test Results	: N/A		
Note:	1. Not applicable for equipment operated with PC, battery, or Power Supply.		

15. Photograph

15.1. Photo of Radiated emissions Test (In Semi Anechoic Chamber)



15.2. Photo of Electrostatic Discharge Test

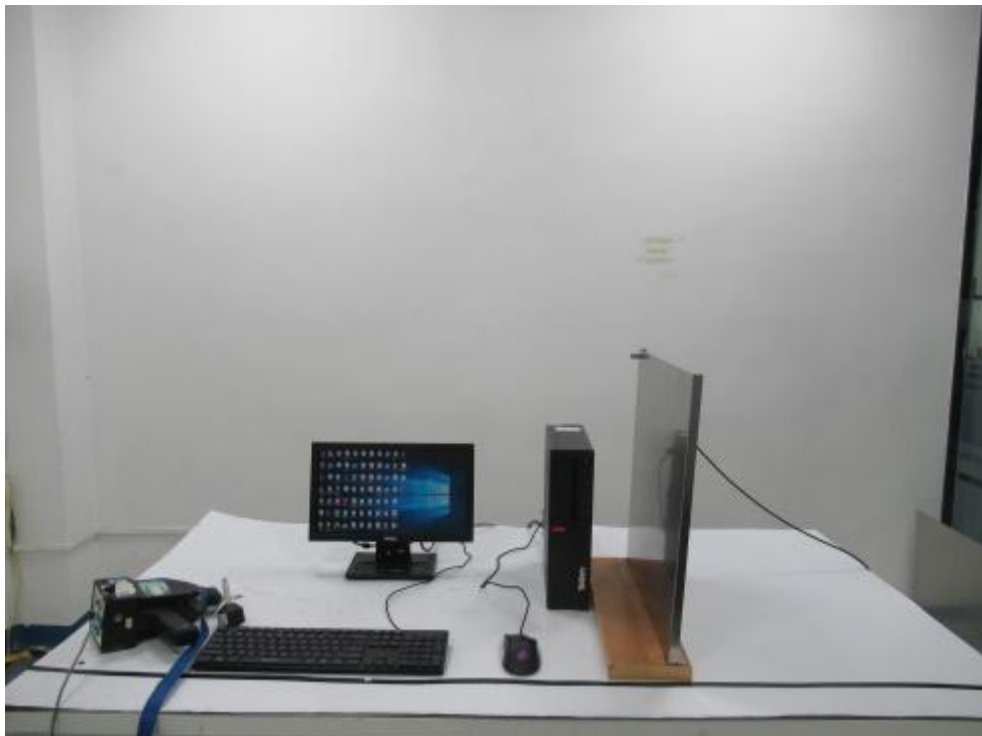

15.3.Photo of RF Field Strength Susceptibility Test



16.Photos Of The EUT



EUT View



EUT View



EUT View



EUT View



EUT View



EUT View



EUT View



EUT View



EUT View

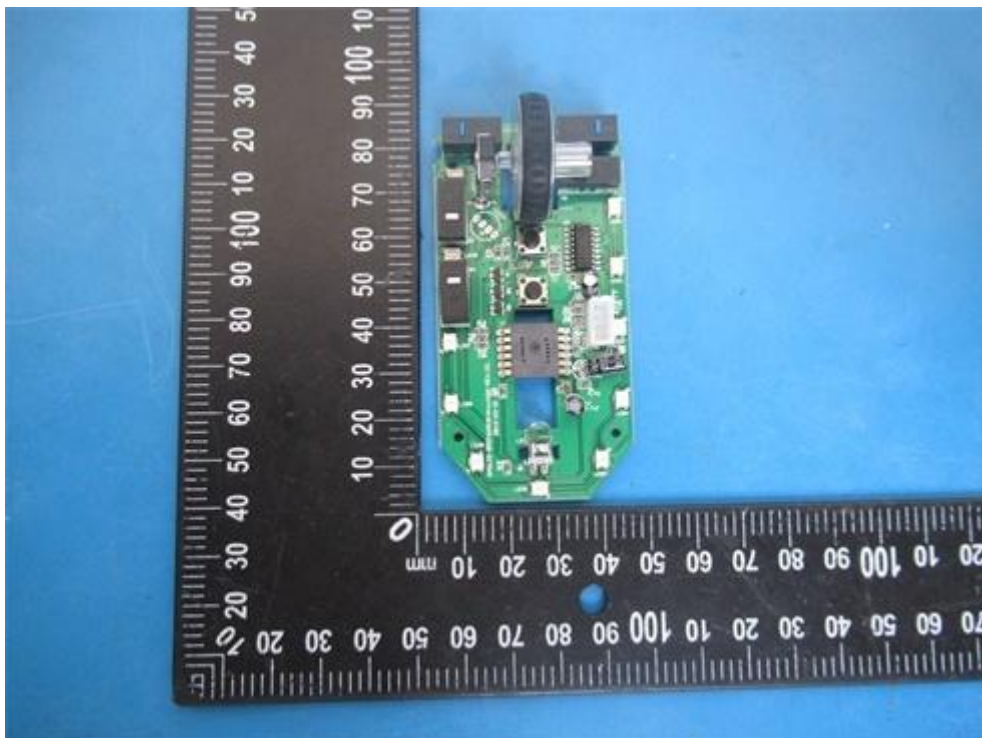

EUT View

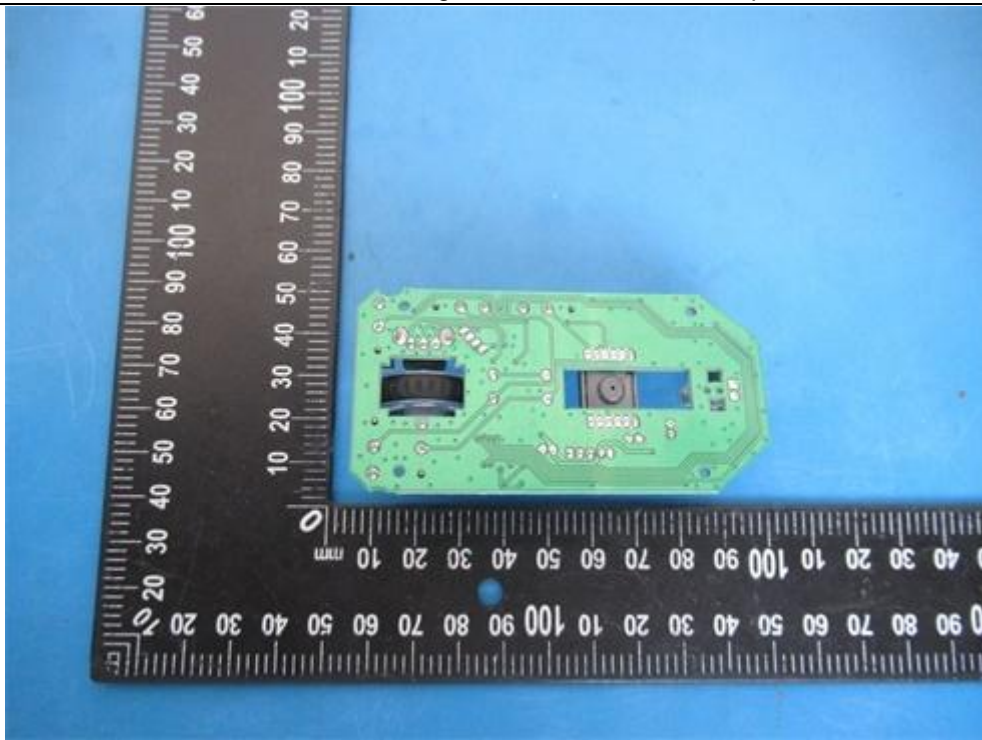

EUT View

----END OF REPORT----