

# CHiQ

## CHEST FREEZER

## MODEL:FCF142DE

|  |               |
|--|---------------|
| CLIMATE CLASS                              | SN/N/ST/T     |
| RATED VOLTAGE                              | 220-240V~     |
| RATED CURRENT                              | 0.95A         |
| RATED FREQUENCY                            | 50HZ          |
| Energy Consumption of E <sub>32</sub>      | 0.6kWh/24h    |
| FREEZER STORAGE VOLUME                     | 142L          |
| INSULATION BLOWING GAS                     | Cyclopentane  |
| CLASS OF PROTECTION AGAINST ELECTRIC SHOCK | Class I       |
| REFRIGERANT/AMOUNT                         | R600a/45g     |
| FREEZING CAPACITY                          | 8kg/24h       |
| TEMPERATURE RISE TIME                      | 12h           |
| NET WEIGHT                                 | 24Kg          |
| PRODUCT DIMENSIONS(W*D*H)                  | 635x556x835mm |

### Diagram of Circuit Principles

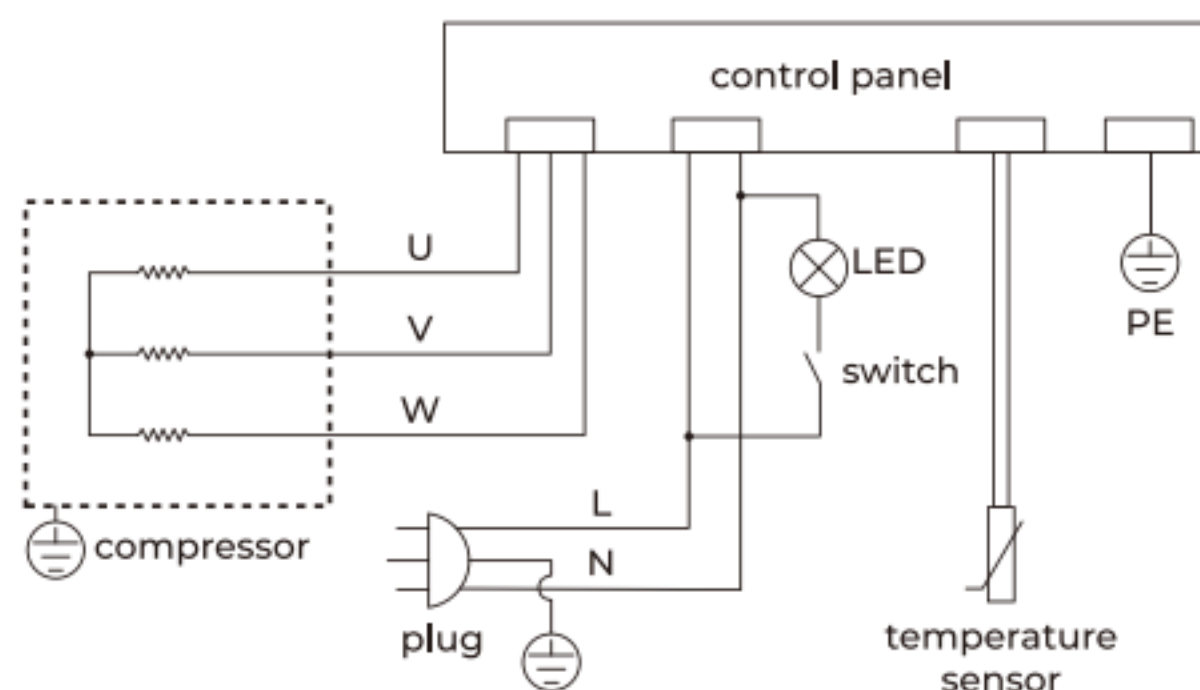

Made in PRC

Serial Number: 印序列号



68 mm

98 mm