



LIAN LI

Feel the difference

O11 DYNAMIC

Installation Guide / 安裝說明書
Guide d'installation / Montageanleitung
Guía de instalación / インストレーションガイド

- * Case components * Composants du boîtier * Guía de instalación
 * 機殻部品紹介 * Gehäusekomponenten * ケース各部紹介

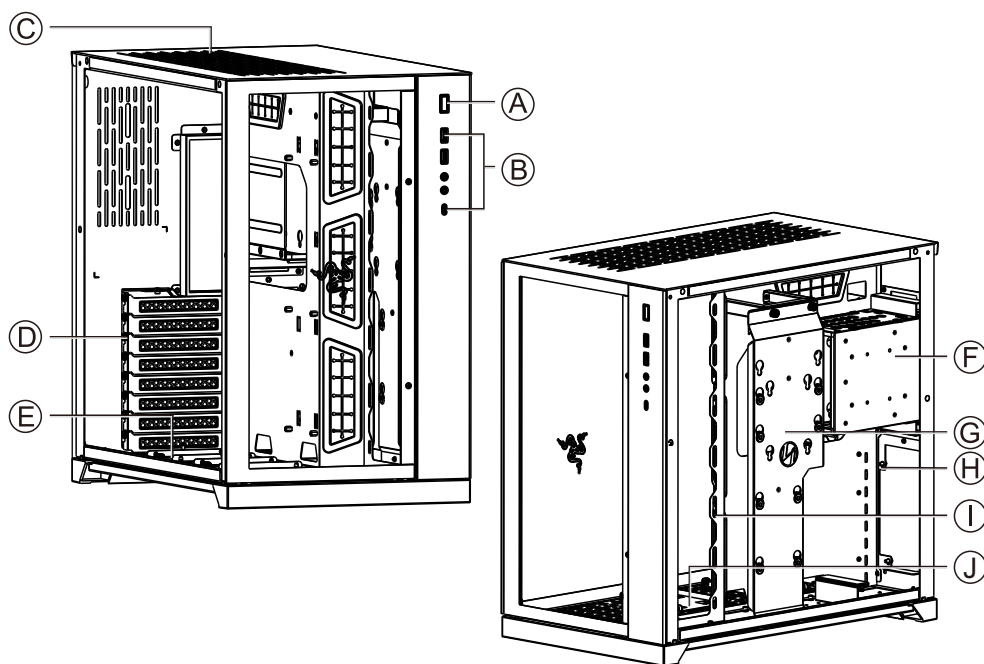

- (A) Power switch / 電源開關按鍵 / 電源スイッチ
- (B) Multi-media ports (USB 3.0 x 2, USB 3.1 Type-C, HD audio) / 多媒體連接埠 / マルチメディアI/Oポート
- (C) Spare 120 mm fans x 3 or 140 mm fans x 2 / 預留 120 mm 風扇 x 3 或 140 mm 風扇 x 2
 追加120 mm ファン x 3 または140 mm ファン x 2
- (D) PCI slots with ventilation / PCI 通風擋片 / 通気構造のPCIスロット
- (E) 2.5" HDD x 2 / 2.5吋硬碟 x 2 / 2.5" HDDマウントスペース x 2
- (F) Removable HDD tray (3.5" HDD x 2 or 2.5" HDD x 2 or PSU x 1) / 可拆硬碟托盤 / リムーバブルHDDトレイ
- (G) Removable HDD tray (3.5" HDD x 1 + 2.5" HDD x 1 or 2.5" HDD x 2) /
 可拆硬碟托盤 / リムーバブルHDDトレイ
- (H) PSU tray / 電源供應器裝置槽 / 電源ユニット固定ステー
- (I) Spare 120 mm fans x 3 / 預留 120 mm 風扇 x 3 / 追加120 mm ファン x 3
- (J) Spare 120 mm fans x 3 / 預留 120 mm 風扇 x 3 / 追加120 mm ファン x 3

*** Hardware list**
* 零件盒部品一覧表

*** Liste des pièces**
* Hardwareliste

*** Lista de materiales**
* 付属品一覧



Screws for motherboard & 2.5" HDD mount

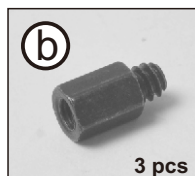

Stand-off bolt (Spare parts) for motherboard mount



Screws for PSU mounting

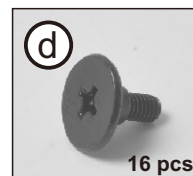

Screws for 2.5" HDD mount

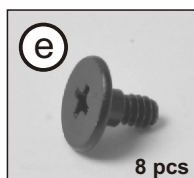

Screws for 3.5" HDD mount

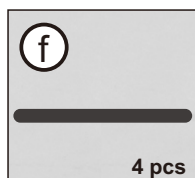

Velcro for cable management

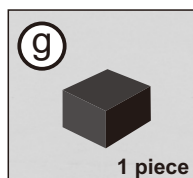

Rubber pad for PSU mounting

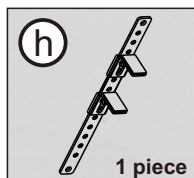

VGA anti-sag bracket for VGA card mount

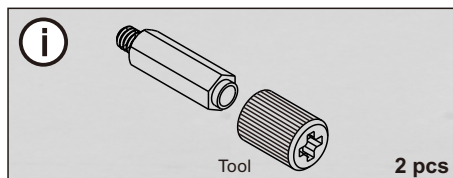

Longer stand-off bolt for VGA anti-sag bracket mounting

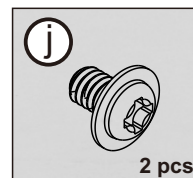

Screws for VGA anti-sag bracket mounting

※ Exceeded quantity are spare parts.
 ※ 多餘的零件數量是備品。
 ※ Les pièces supplémentaires sont des pièces de rechange.
 ※ Zusätzliche Teile können als Ersatzteile verwendet werden.
 ※ Exceeded quantity are spare parts.
 ※ ネジには予備が含まれてています。

- * Remove top panel
- * 卸下頂部面板
- * Retirer le panneau supérieur
- * Entfernen Sie die obere Abdeckung
- * Retire el panel superior
- * トップパネルを取り外す

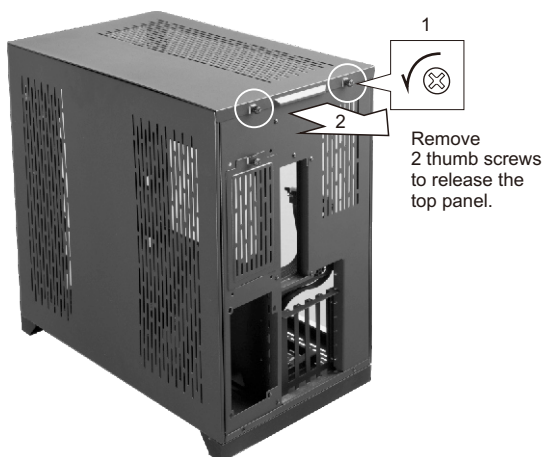

- * Remove side glass & front glass
- * 卸下側面玻璃及前面玻璃
- * Enlever le verre latéral et frontal
- * Entfernen Sie die Seiten- und Frontscheibe
- * Retire el vidrio lateral y frontal
- * サイド&フロントガラスを取り外す



Pull to release the glass.

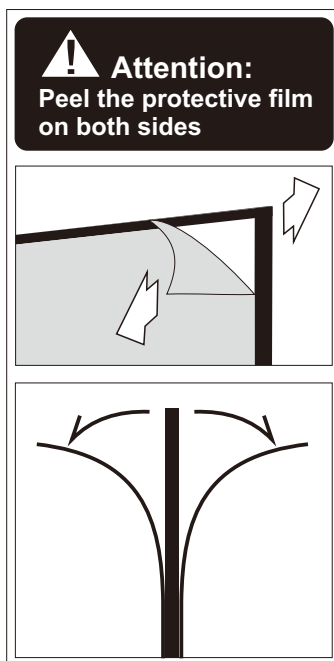
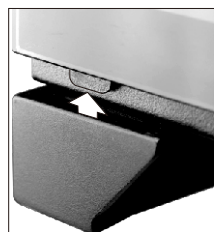

- * PSU installation
- * 電源供應器安裝
- * Installation du plateau du bloc d'alimentation

- * PSU-Einsatz installieren
- * Instalación de la fuente de alimentación
- * 電源ユニットの取り付け

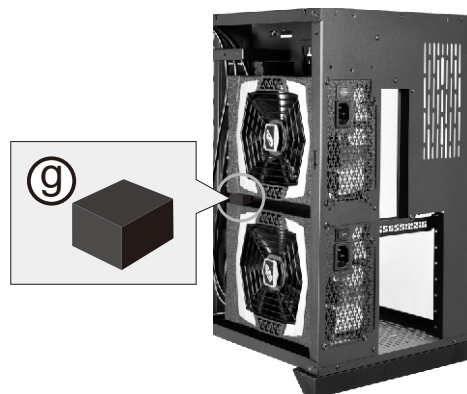
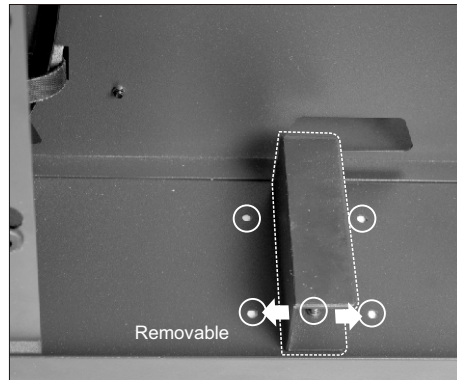
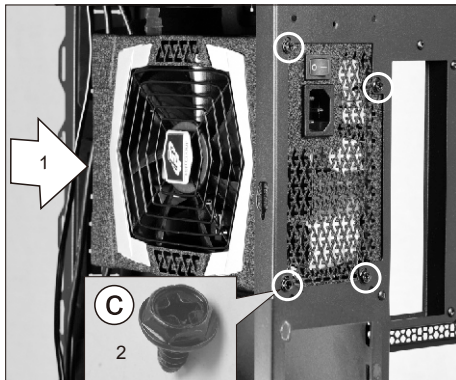
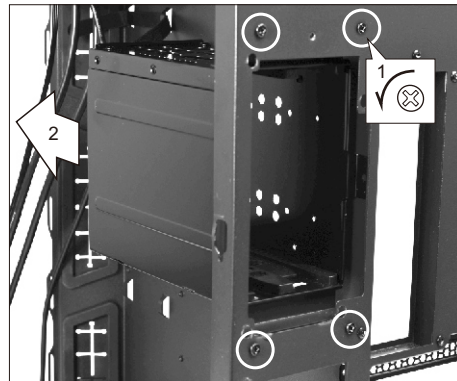
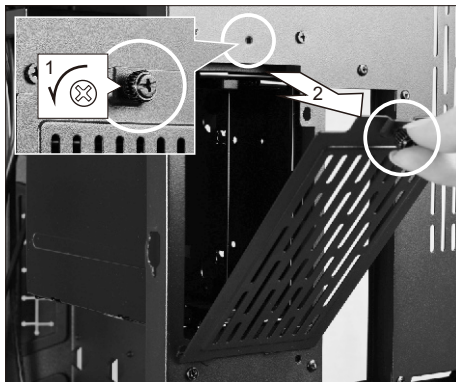

- * Motherboard installation
- * 主機板安裝
- * Installation de la carte mère
- * Motherboard installieren
- * Instalación de la placa base
- * マザーボードの取り付け

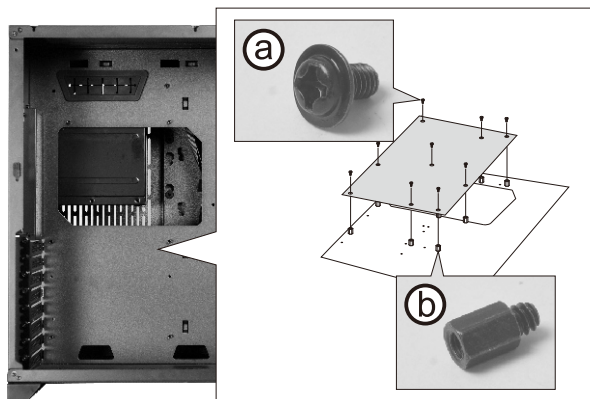

- * 2.5"/3.5" HDD installation
- * 2.5/3.5吋硬碟安裝
- * Installation d'un DD 2.5"/3.5"

- * 2.5/3.5-Zoll-Festplatte installieren
- * Instalación de unidad de disco duro de 2.5"/3.5"
- * 2.5"/3.5" ハードディスクの取り付け

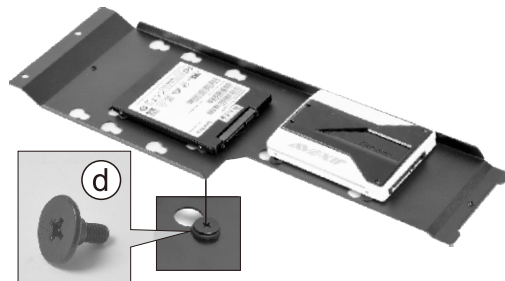
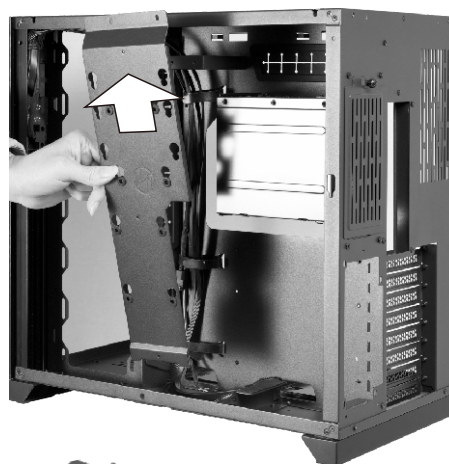

- * 2.5"/3.5" HDD installation
- * 2.5/3.5吋硬碟安裝
- * Installation d'un DD 2.5"/3.5"

- * 2.5/3.5-Zoll-Festplatte installieren
- * Instalación de unidad de disco duro de 2.5"/3.5"
- * 2.5"/3.5" ハードディスクの取り付け

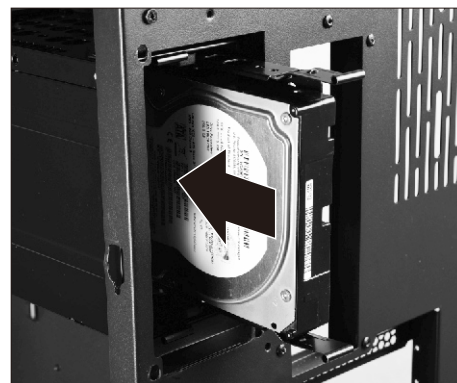
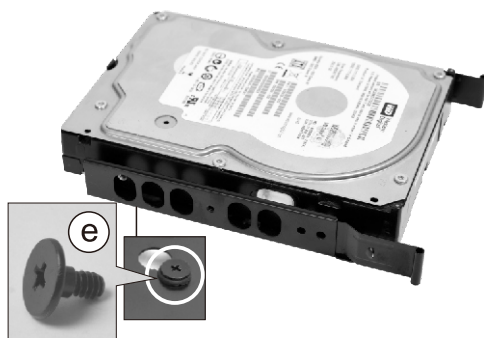
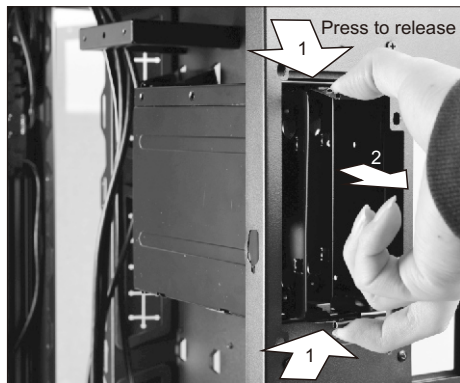
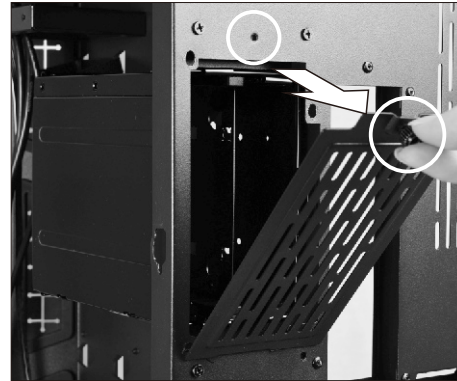
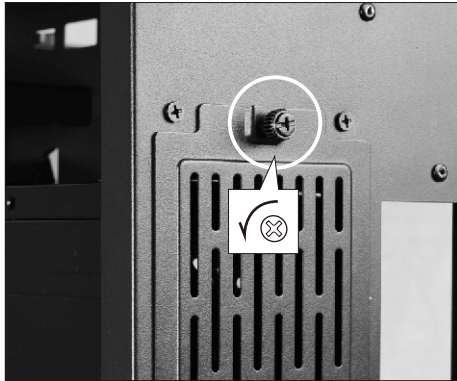

- * 2.5" HDD installation
- * 2.5吋硬碟安裝
- * Installation d'un DD2.5"
- * 2.5-Zoll-Festplatte installieren
- * Instalación de unidad de disco duro de 2.5"
- * 2.5"ハードディスクの取り付け

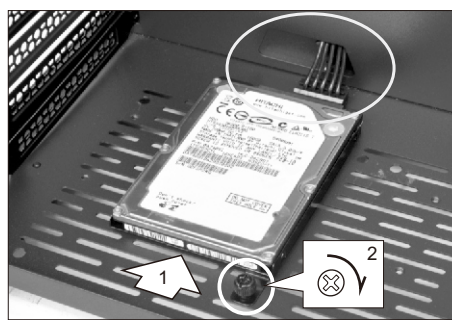
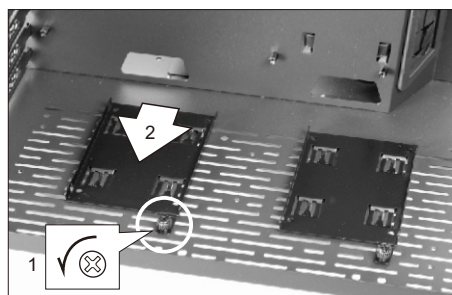
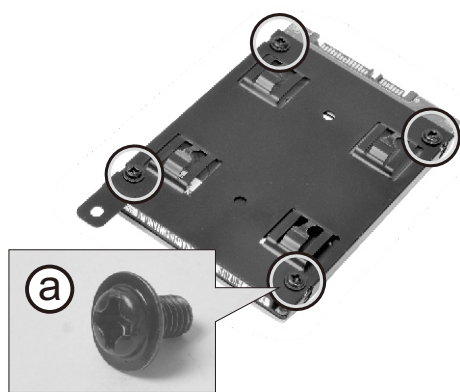

- * Remove air filters
- * 空氣濾網拆卸
- * Retirez les filtres à air
- * Entfernen Sie Luftfilter
- * Retire los filtros de aire
- * エアフィルターの取り外し

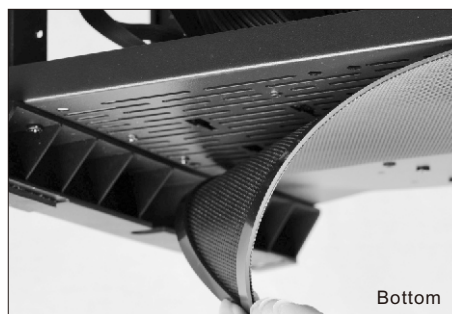
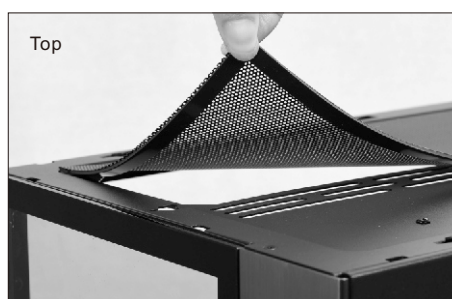
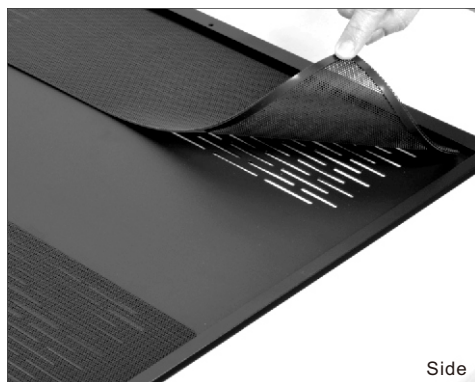

- * Cable management
- * 線材管理
- * Gestion des câbles
- * Kabelmanagement
- * Mantenimiento de cable
- * ケーブル管理

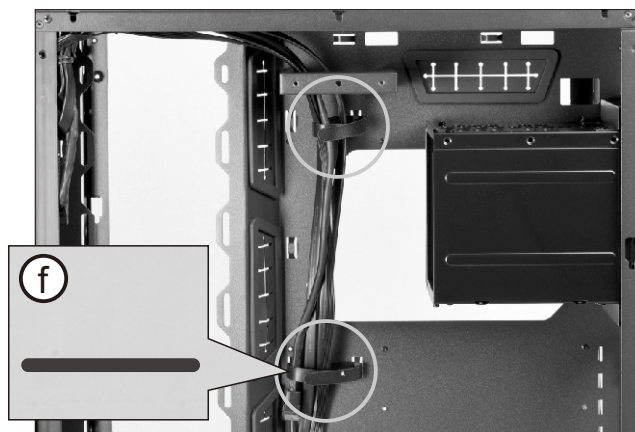

- * Radiator & cooling support
- * 散熱器 & 水冷排支援
- * Assistance radiateur et refroidissement
- * Kühler- und Kühlungsunterstützung
- * Radiador y soporte de refrigeración.
- * ラジエーター & 冷却サポート

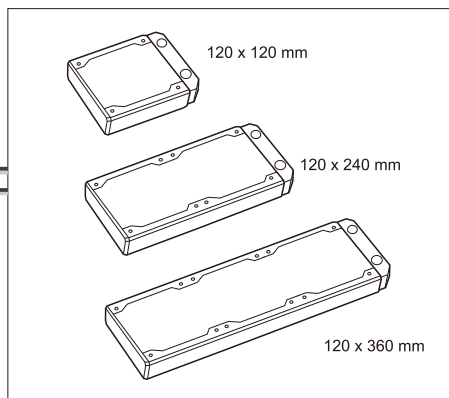
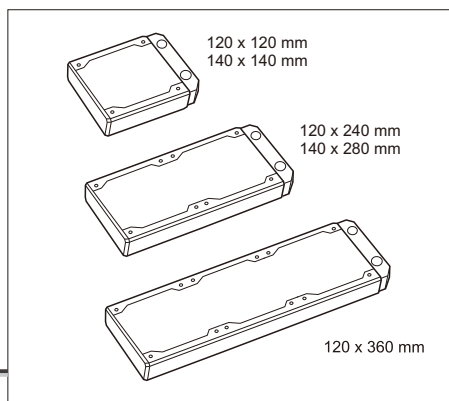
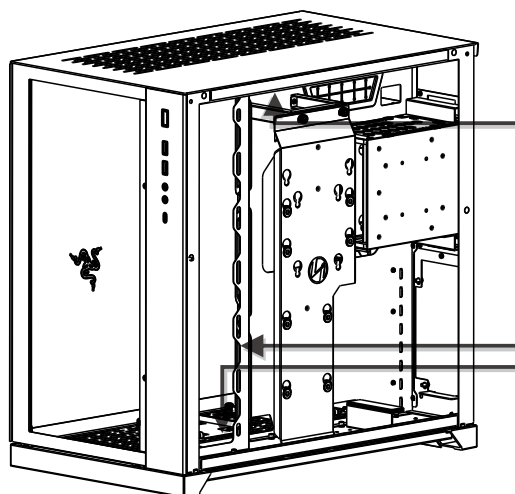

*** Hardware clearance**
*** 硬體擴充支援**

*** Passage de matériel**
*** Hardware-Freigabe**

*** Limpieza de hardware**
*** ハードウェア拡張のサポート**

- CPU air cooler
- GPU
- PSU with bracket
- PSU without bracket
- Radiator clearance

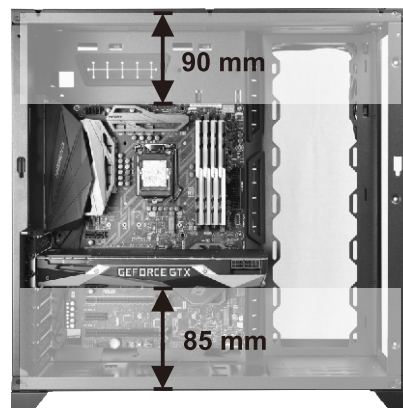
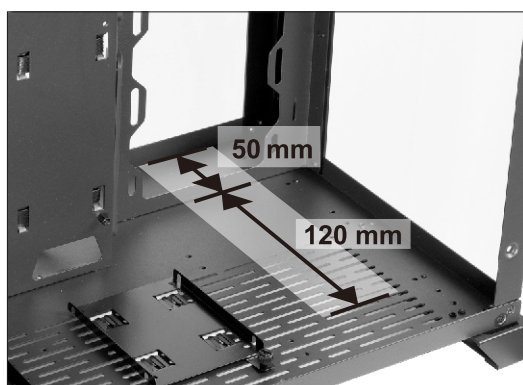
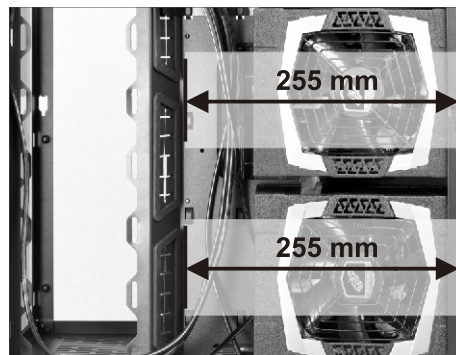
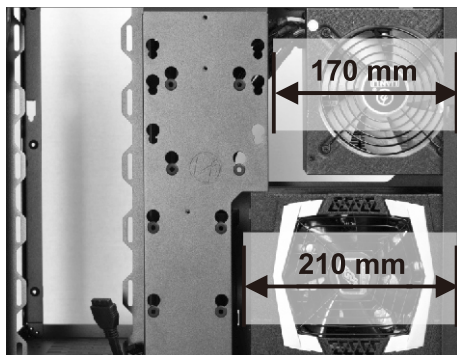
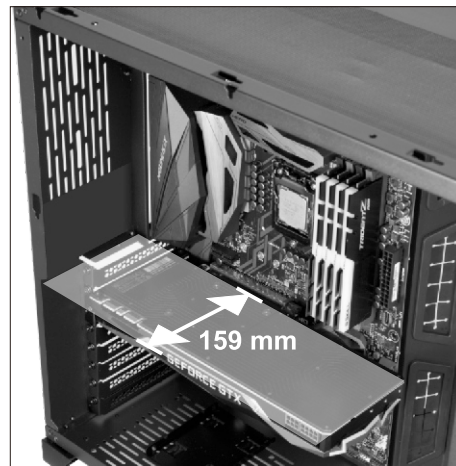
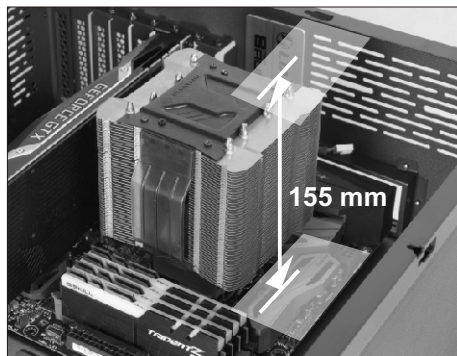

- * VGA Anti-sag bracket installation
- * VGA防下垂支架安裝
- * Installation du support anti-affaissement VGA
- * Installation der Anti-Sag-Halterung für VGA
- * Instalación de soporte VGA anti-hundimiento
- * VGA垂れ防止ブラケットの取り付け

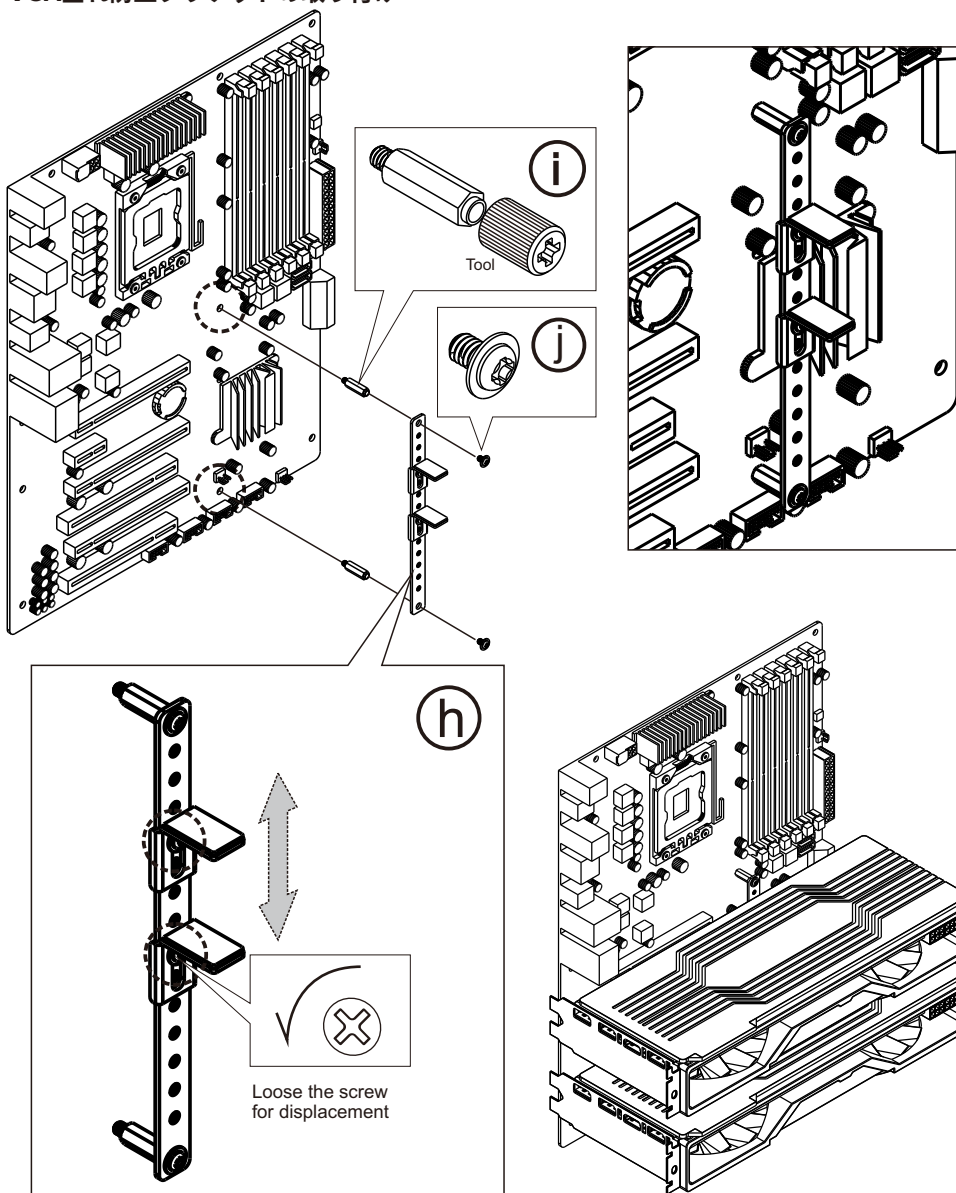



O11 DYNAMIC

Option kits / 選配套件
Kits optionnels / Optionale Sets
Kits opcionales / オプションパーツ

Model: O11D-1 X

Upright Display Card Kits

(200 mm PCI-e Express 16X Riser Card Adapter Extender Cable Kit)

* PCI-e 2.0, PCI-e 3.0

* High bandwidth

* Safety / Flatness

* Data rates up to 8 Gbps

Package Content:

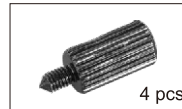
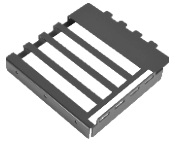

4 pcs



4 pcs

Installation:

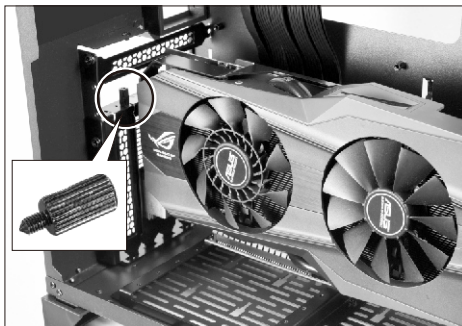
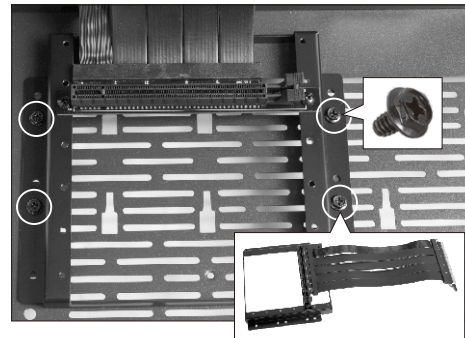
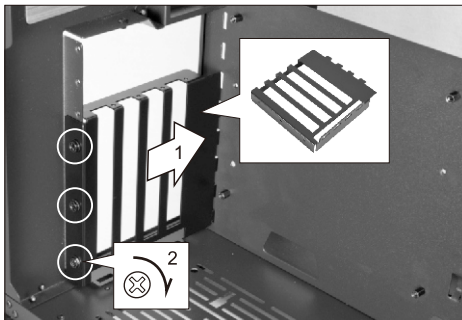

- * I/O port installation
- * USB 3.0 / HD Audio 接線定義
- * Installation du port E/S
- * I/O-Port installieren
- * Instalación de los puertos de E/S
- * I/O ポートに関して

USB 3.0

Supports motherboard
USB 3.0 20 Pin header

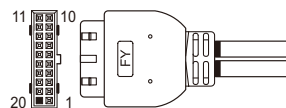

HD AUDIO

Blue	10	9	Green	
Black	purple	8	7	Key
Yellow	6	5	Orange	
Gray	4	3	N.C.	
Red	2	1	GND+H.S. TUBE	

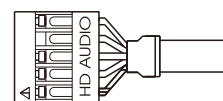

- * LED Control board installation
- * LED控制板安裝
- * Installation du tableau de commande LED
- * Installation der LED-Steuerplatine
- * Instalación del tablero de control LED
- * LEDコントロールボードの設置

