



FQ60XPE

en	Instruction Manual
it	Manuale di istruzioni
pt	Manual de Instruções
nl	Gebruiksaanwijzing
fr	Notice d'Utilisation
sv	Bruksanvisning
da	Brugsvejledning
es	Manual de instrucciones
ru	Холодильник
de	Bedienungsanleitung



Please read this manual first!

Dear Customer,

We hope that your product, which has been produced in modern plants and checked under the most meticulous quality control procedures, will provide you an effective service.

For this, we recommend you to carefully read the entire manual of your product before using it and keep it at hand for future references.



This manual

- Will help you use your appliance in a fast and safe way.
- Read the manual before installing and operating your product.
- Follow the instructions, especially those for safety.
- Keep the manual in an easily accessible place as you may need it later.
- Besides, read also the other documents provided with your product.

Please note that this manual may be valid for other models as well.

Symbols and their descriptions

This instruction manual contains the following symbols:

-  Important information or useful usage tips.
-  Warning against dangerous conditions for life and property.
-  Warning against electric voltage.



This product is supplied with the selective sorting symbol for waste electrical and electronic equipment (WEEE). This means that this product must be handled pursuant to European Directive 2002/96/EC in order to be recycled or dismantled to minimise its impact on the environment. For further information, please contact your local or regional authorities.

Electronic products not included in the selective sorting process are potentially dangerous for the environment and human health due to the presence of hazardous substances.

CONTENTS

1 Your refrigerator	3	4 Preparation	12
2 Important Safety Warnings	4	5 Using your refrigerator	13
Intended use	4	Indicator Panel.....	13
For products with a water dispenser; .	6	Egg tray.....	16
Child safety.....	6	Sliding Body Shelves	16
HCA Warning	6	Crisper	16
Things to be done for energy saving ..	7	Chiller compartment	16
		Rotating Middle Section	17
		Multi Zone Storage Compartment ..	17
		Blue light	17
3 Installation	8	6 Maintenance and cleaning	18
Preparation.....	8	Protection of plastic surfaces	18
Points to be considered when re-transporting your refrigerator	8		
Before operating your refrigerator	9	7 Recommended solutions for the problems	19
Electric connection	9		
Disposing of the packaging	9		
Disposing of your old refrigerator	9		
Placing and Installation	10		
Floor balance adjustment	10		
Adjusting the gap between the upper door	11		

1 Your refrigerator

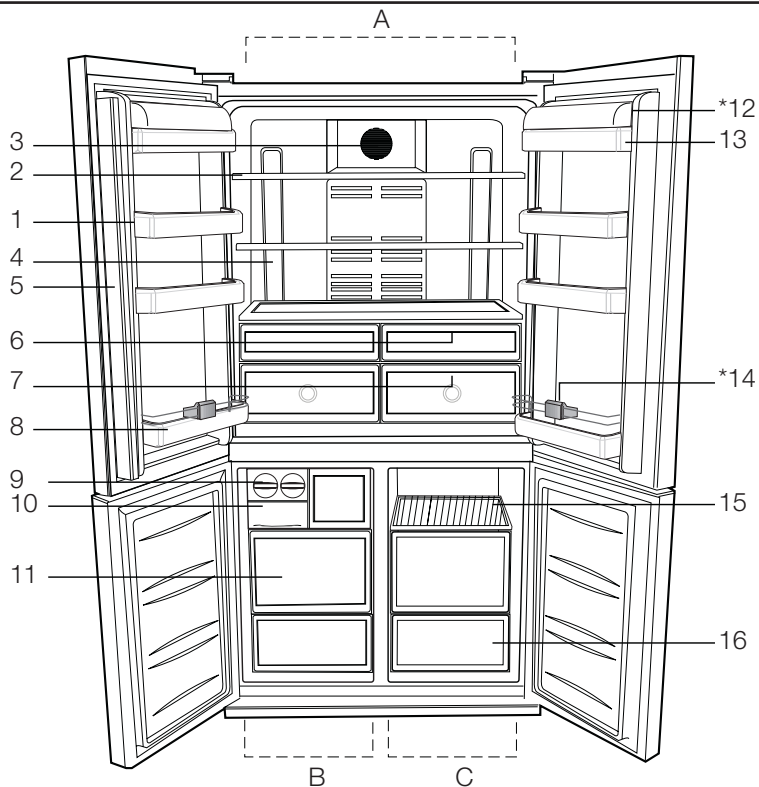

- A- Fridge compartment
- B- Freezer compartment
- C- Multi Zone

- | | |
|--|--------------------------------------|
| 1- Fridge compartment door shelves | 8- Bottle shelf |
| 2- Fridge compartment adjustable cabinet shelves | 9- Icematic |
| 3- Diffuser cover | 10- Icebox |
| 4- Illumination lens | 11- Frozen food storage compartments |
| 5- Rotating middle section | 12- Butter & Cheese shelf cover |
| 6- Chiller compartment | 13- Butter & Cheese shelf |
| 7- Crisper | 14- Bottle holder |
| | 15- Multi Zone compartment shelves |
| | 16- Multi Zone compartment |
| | * OPTIONAL |

i Figures that take place in this instruction manual are schematic and may not correspond exactly with your product. If the subject parts are not included in the product you have purchased, then it is valid for other models.

2 Important Safety Warnings

Please review the following information. Failure to observe this information may cause injuries or material damage. Otherwise, all warranty and reliability commitments will become invalid.

The usage life of the unit you purchased is 10 years. This is the period for keeping the spare parts required for the unit to operate as described.

Intended use

This product is intended to be used

- indoors and in closed areas such as homes;
- in closed working environments such as stores and offices;
- in closed accommodation areas such as farm houses, hotels, pensions.
- This product should not be used outdoors.

General safety

- When you want to dispose/scrap the product, we recommend you to consult the authorized service in order to learn the required information and authorized bodies.
- Consult your authorized service for all your questions and problems related to the refrigerator. Do not intervene or let someone intervene to the refrigerator without notifying the authorised services.
- For products with a freezer compartment; Do not eat cone ice cream and ice cubes immediately after you take them out of the freezer compartment! (This may cause frostbite in your mouth.)
- For products with a freezer compartment; Do not put bottled and canned liquid beverages in the freezer compartment. Otherwise, these may burst.
- Do not touch frozen food by hand; they may stick to your hand.
- Unplug your refrigerator before cleaning or defrosting.
- Vapor and vaporized cleaning materials should never be used in cleaning and defrosting processes of your refrigerator. In such cases, the vapor may get in contact with the electrical parts and cause short circuit or electric shock.
- Never use the parts on your refrigerator such as the door as a means of support or step.
- Do not use electrical devices inside the refrigerator.
- Do not damage the parts, where the refrigerant is circulating, with drilling or cutting tools. The refrigerant that might blow out when the gas channels of the evaporator, pipe extensions or surface coatings are punctured causes skin irritations and eye injuries.
- Do not cover or block the ventilation holes on your refrigerator with any material.
- Electrical devices must be repaired by only authorised persons. Repairs performed by incompetent persons create a risk for the user.
- In case of any failure or during a maintenance or repair work, disconnect your refrigerator's mains supply by either turning off the relevant fuse or unplugging your appliance.

- Do not pull by the cable when pulling off the plug.
- Place the beverage with higher proofs tightly closed and vertically.
- Never store spray cans containing flammable and explosive substances in the refrigerator.
- Do not use mechanical devices or other means to accelerate the defrosting process, other than those recommended by the manufacturer.
- This product is not intended to be used by persons with physical, sensory or mental disorders or unlearned or inexperienced people (including children) unless they are attended by a person who will be responsible for their safety or who will instruct them accordingly for use of the product
- Do not operate a damaged refrigerator. Consult with the service agent if you have any concerns.
- Electrical safety of your refrigerator shall be guaranteed only if the earth system in your house complies with standards.
- Exposing the product to rain, snow, sun and wind is dangerous with respect to electrical safety.
- Contact authorized service when there is a power cable damage to avoid danger.
- Never plug the refrigerator into the wall outlet during installation. Otherwise, risk of death or serious injury may arise.
- This refrigerator is intended for only storing food items. It must not be used for any other purpose.
- Label of technical specifications is located on the left wall inside the refrigerator.
- Never connect your refrigerator to electricity-saving systems; they may damage the refrigerator.
- If there is a blue light on the refrigerator, do not look at the blue light with optical tools.
- For manually controlled refrigerators, wait for at least 5 minutes to start the refrigerator after power failure.
- This operation manual should be handed in to the new owner of the product when it is given to others.
- Avoid causing damage on power cable when transporting the refrigerator. Bending cable may cause fire. Never place heavy objects on power cable. Do not touch the plug with wet hands when plugging the product.
- Do not plug the refrigerator if the wall outlet is loose.
- Water should not be sprayed directly on inner or outer parts of the product for safety purposes.
- Do not spray substances containing inflammable gases such as propane gas near the refrigerator to avoid fire and explosion risk.
- Never place containers filled with water on top of the refrigerator, otherwise this may cause electric shock or fire.
- Do not overload your refrigerator with excessive amounts of food. If overloaded, the food items may fall down and hurt you and damage refrigerator when you open the door. Never place objects on top of the refrigerator; otherwise, these objects may fall down when you open or close the refrigerator's door.

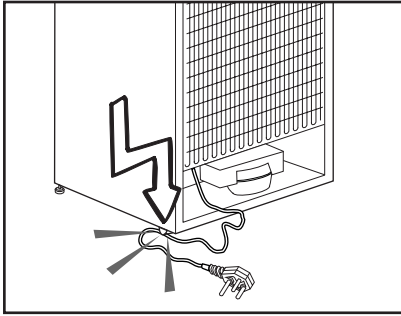

- As they require a precise temperature, vaccines, heat-sensitive medicine and scientific materials and etc. should not be kept in the refrigerator.
- If not to be used for a long time, refrigerator should be unplugged. A possible problem in power cable may cause fire.
- The plug's tip should be regularly cleaned; otherwise, it may cause fire.
- Refrigerator may move if adjustable legs are not properly secured on the floor. Properly securing adjustable legs on the floor can prevent the refrigerator to move.
- When carrying the refrigerator, do not hold it from door handle. Otherwise, it may be snapped.
- When you have to place your product next to another refrigerator or freezer, the distance between devices should be at least 8cm. Otherwise, adjacent side walls may be humidified.

For products with a water dispenser;

Pressure of water mains should be minimum 1 bar. Pressure of water mains should be maximum 8 bars.

- Use only potable water.

Child safety

- If the door has a lock, the key should be kept away from reach of children.
- Children must be supervised to prevent them from tampering with the product.

HCA Warning

If your product's cooling system contains R600a:

This gas is flammable. Therefore, pay attention to not damaging the cooling system and piping during usage and transportation. In the event of damage, keep your product away from potential fire sources that can cause the product catch a fire and ventilate the room in which the unit is placed.

Ignore this warning if your product's cooling system contains R134a.

Type of gas used in the product is stated in the type plate which is on the left wall inside the refrigerator.

Never throw the product in fire for disposal.

Things to be done for energy saving

- Do not leave the doors of your refrigerator open for a long time.
- Do not put hot food or drinks in your refrigerator.
- Do not overload your refrigerator so that the air circulation inside of it is not prevented.
- Do not install your refrigerator under direct sunlight or near heat emitting appliances such as ovens, dishwashers or radiators.
- Pay attention to keep your food in closed containers.
- For products with a freezer compartment; You can store maximum amount of food items in the freezer when you remove the shelf or drawer of the freezer. Energy consumption value stated for your refrigerator has been determined by removing freezer shelf or drawer and under maximum load. There is no harm to use a shelf or drawer according to the shapes and size of food to be frozen.
- Thawing frozen food in fridge compartment will both provide energy saving and preserve the food quality.

3 Installation

⚠ Please remember that the manufacturer shall not be held liable if the information given in the instruction manual is not observed.

Preparation

- Your refrigerator should be installed at least 30 cm away from heat sources such as hobs, ovens, central heater and stoves and at least 5 cm away from electrical ovens and should not be located under direct sunlight.
- The ambient temperature of the room where you install your refrigerator should at least be 10°C. Operating your refrigerator under cooler conditions than this is not recommended with regard to its efficiency.
- Please make sure that the interior of your refrigerator is cleaned thoroughly.
- If two refrigerators are to be installed side by side, there should be at least 2 cm distance between them.
- When you operate your refrigerator for the first time, please observe the following instructions during the initial six hours.
 - The door should not be opened frequently.
 - It must be operated empty without any food in it.
 - Do not unplug your refrigerator. If a power failure occurs out of your control, please see the warnings in the "Recommended solutions for the problems" section.
- Original packaging and foam materials should be kept for future transportations or moving.

Points to be considered when re-transporting your refrigerator

1. Your refrigerator must be emptied and cleaned prior to any transportation.
2. Shelves, accessories, crisper and etc. in your refrigerator must be fastened securely by adhesive tape against any jolt before repackaging.
3. Packaging must be tied with thick tapes and strong ropes and the rules of transportation printed on the package must be followed.

Please do not forget...

Every recycled material is an indispensable source for the nature and for our national resources. If you wish to contribute to recycling the packaging materials, you can get further information from the environmental bodies or local authorities.

Before operating your refrigerator

Before starting to use your refrigerator check the following:

1. Is the interior of the refrigerator dry and can the air circulate freely in the rear of it?
2. Insert the 2 plastic wedges onto the rear ventilation as illustrated in the following figure. Unscrew the existing ones and use the screws given in the same bag of wedges. Plastic wedges

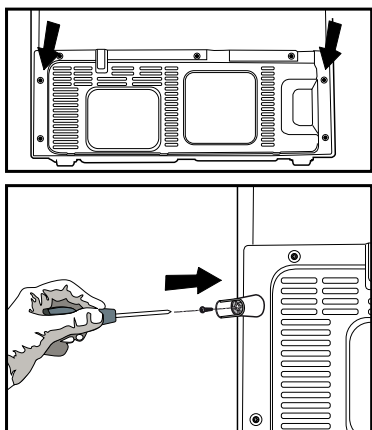

will provide the required distance between your refrigerator and the wall in order to allow the air circulation.

3. Clean the interior of the refrigerator as recommended in the “Maintenance and cleaning” section.
4. Plug the refrigerator into the wall outlet. When the door is open the respective interior light will come on.
5. You will hear a noise as the compressor starts up. The liquid and gases sealed within the refrigeration system may also give rise to noise, even if the compressor is not running and this is quite normal.
6. Front edges of the refrigerator may feel warm. This is normal. These areas are designed to be warm to avoid condensation.

Electric connection

Connect your refrigerator to a grounded socket which is being protected by a fuse with the appropriate capacity.

Important:

- The connection must be in compliance with national regulations.
 - The power cable plug must be easily accessible after installation.
 - Voltage and allowable fuse protection are specified in the “Technical Specifications” section.
 - The specified voltage must be equal to your mains voltage.
 - Extension cables and multiway plugs must not be used for connection.
- ⚠ A damaged power cable must be replaced by a qualified electrician.
- ⚠ The appliance must not be operated before it is repaired! There is danger of electric shock!

Disposing of the packaging

The packing materials may be dangerous for children. Keep the packing materials out of the reach of children or dispose them of by classifying them in accordance with the waste instructions. Do not dispose them of along with the normal household waste.

The packing of your refrigerator is produced from recyclable materials.

Disposing of your old refrigerator

Dispose of your old machine without giving any harm to the environment.

- You may consult your authorized dealer or waste collection center of your municipality about the disposal of your refrigerator.

Before disposing of your refrigerator, cut out the electric plug and, if there are any locks on the door, make them inoperable in order to protect children against any danger.

Placing and Installation

Caution: Never plug the refrigerator into the wall outlet during installation. Otherwise, risk of death or serious injury may arise.

If the entrance door of the room where the refrigerator will be installed is not wide enough for the refrigerator to pass through, than call the authorized service to have them remove the doors of your refrigerator and pass it sideways through the door.

1. Install your refrigerator to a place that allows ease of use.
2. Keep your refrigerator away from heat sources, humid places and direct sunlight.
3. There must be appropriate air ventilation around your refrigerator in order to achieve an efficient operation. If the refrigerator is to be placed in a recess in the wall, there must be at least 5 cm distance with the ceiling and at least 5 cm with the wall.

If the floor is covered with a carpet, your product must be elevated 2.5 cm from the floor.

4. Place your refrigerator on an even floor surface to prevent jolts.

5. Do not keep your refrigerator in ambient temperatures under 10°C.

Floor balance adjustment

If your refrigerator is unbalanced;

1- Ventilation cover is removed by unscrewing its screws as illustrated in the figure before the procedure. You can balance your refrigerator by turning the front legs of it as illustrated in the figure. The corner where the leg exists is lowered when you turn in the direction of black arrow and raised when you turn in the opposite direction. Taking help from someone to slightly lift the refrigerator will facilitate this process.

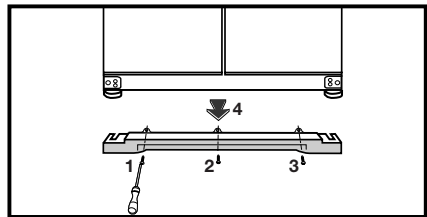
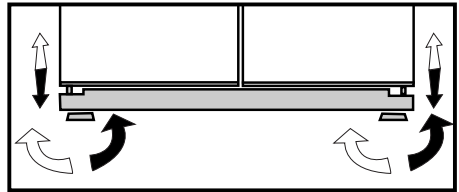

2. After the balance issue is remedied, install back the ventilation cover and fasten the screws.

3. Remove the screws fastening the lower ventilation cover using a Phillips screwdriver.

Adjusting the gap between the upper door

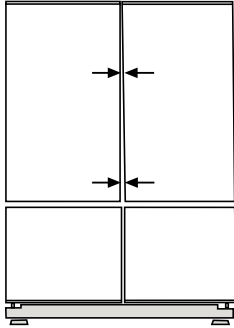

- You can adjust the gap between the fridge compartment doors as illustrated in the figures.

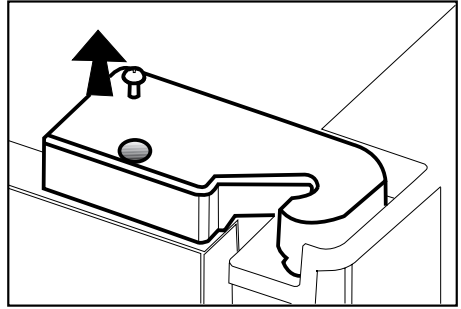

- Adjust the door as you desire by loosening the screws.

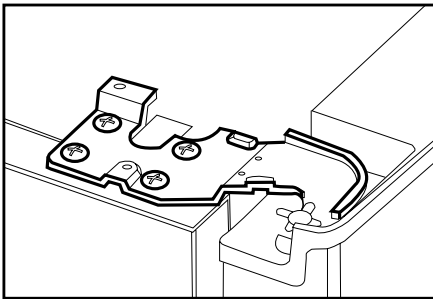

Door shelves should be empty when adjusting the door height.

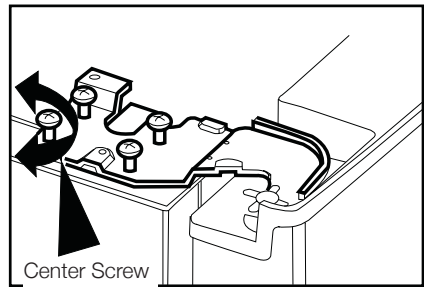

- Fix the door you have adjusted by tightening the screws without changing the position of the door.

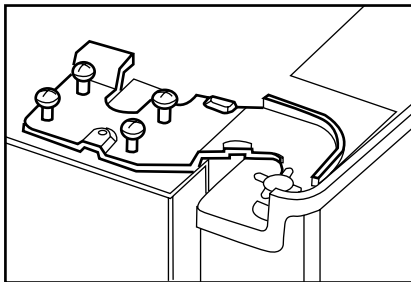

- Using a screwdriver, remove the screw of upper hinge cover of the door you want to adjust.

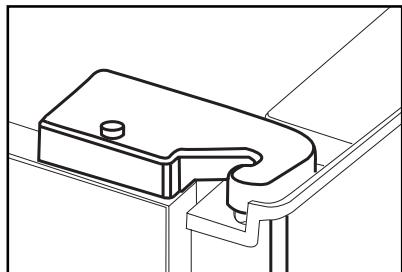

- Replace the hinge cover and fix with the screw.

4 Preparation

- i** Your refrigerator should be installed at least 30 cm away from heat sources such as hobs, ovens, central heater and stoves and at least 5 cm away from electrical ovens and should not be located under direct sunlight.
- i** The ambient temperature of the room where you install your refrigerator should at least be 10°C. Operating your refrigerator under cooler conditions than this is not recommended with regard to its efficiency.
- i** Please make sure that the interior of your refrigerator is cleaned thoroughly.
- i** If two refrigerators are to be installed side by side, there should be at least 2 cm distance between them.
- i** When you operate your refrigerator for the first time, please observe the following instructions during the initial six hours.
 - The door should not be opened frequently.
 - It must be operated empty without any food in it.
 - Do not unplug your refrigerator. If a power failure occurs out of your control, please see the warnings in the “Recommended solutions for the problems” section.
- i** Original packaging and foam materials should be kept for future transportations or moving.

5 Using your refrigerator

Indicator Panel

This touch-control indicator panel allows you to set the temperature without opening the door of your refrigerator. Just touch the relevant button with your finger to set the temperature.

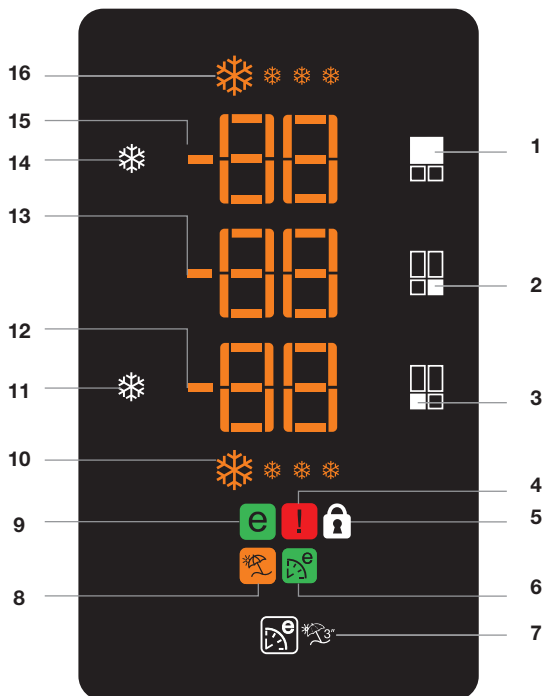

1. Fridge Compartment Temperature Setting Button
2. Flexi Zone Storage Compartment Temperature Setting Button
3. Freezer Compartment Temperature Setting Button
4. Error Status Indicator
5. Key Lock Indicator
6. Eco Extra Function Indicator
7. Eco Extra/Vacation Button
8. Vacation Function Indicator
9. Economy Mode Indicator
10. Quick Freeze Function Indicator
11. Fast Freeze Button
12. Freezer Compartment Temperature Indicator
13. Flexi Zone Storage Compartment Temperature Indicator
14. Quick Cool Button
15. Fridge Compartment Temperature Indicator
16. Quick Cool Function Indicator

I Figures that take place in this instruction manual are schematic and may not correspond exactly with your product. If the subject parts are not included in the product you have purchased, then it is valid for other models.

1. Fridge Compartment Temperature Setting Button

Press this button to set the temperature of the fridge compartment to 8, 6, 4, 2, 8... respectively.

Press this button to set the desired temperature for the Fridge Compartment.

2. Flexi Zone Storage Compartment Temperature Setting Button

You can set the Flexi Zone Storage Compartment either as a Freezer or a Cooler. Press and hold this button for 3 sec. to set the Flexi Zone Storage Compartment either as a Freezer or a Cooler. This compartment is set as a Freezer Compartment at factory.

3. Freezer Compartment Temperature Setting Button

Press this button to set the temperature of the freezer compartment to -18, -20, -22, -24, -18... respectively. Press this button to set the desired temperature for the Freezer Compartment.

4. Error Status Indicator

If your refrigerator does not cool adequately or if there is a sensor failure, this indicator will be activated. When this indicator is active, Freezer Compartment Temperature indicator will display "E" and Fridge Compartment Temperature Indicator will display numbers such as "1,2,3...". These numbers on the indicator provides information about the error to the service personnel.

5. Key Lock Indicator

It is activated by pressing Fridge Compartment Temperature Setting Button and Freezer Compartment Temperature Setting Button.

Use this function if you do not want your refrigerator temperature setting changed.

Press Fridge compartment Temperature Setting Button and Freezer Compartment Temperature Setting Button simultaneously for 3 sec. to activate this feature.

Press the relevant buttons again to deactivate this function.

6. Eco Extra Function Indicator

It indicates that the Eco-Extra function is active. If this function is active, your refrigerator will automatically detect the least usage periods and energy-efficient cooling will be performed during those times. Economy indicator will be active while energy-efficient cooling is performed.

Press the relevant button again to deactivate this function.

7. Eco Extra/Vacation Button

Press this button briefly to activate the Eco Extra function. Press and hold this button for 3 sec. to activate the Vacation function. Press this button again to deactivate the selected function.

8. Vacation Function Indicator

Indicates that the vacation function is active. If this function is active, "- -" appears on the indicator of the fridge compartment and no cooling is performed in the fridge compartment. Other compartments will be cooled in accordance with the temperature set for them.

Press the relevant button again to deactivate this function.

9. Economy Mode Indicator

Indicates that the refrigerator is running in energy-efficient mode. This indicator will be active if the Freezer Compartment temperature is set to -18 or the energy efficient cooling is being performed due to Eco-Extra function.

10. Quick Freeze Function Indicator

It indicates that the Fast Freeze function is active.

Use this function when you place fresh food into the freezer compartment or when you need ice. When this function is active, your refrigerator will run for 6 hours without stopping.

Press the relevant button again to deactivate this function.

11. Fast Freeze Button

Press this button briefly to activate the Fast Freeze function. Press this button again to deactivate the selected function.

12. Freezer Compartment Temperature Indicator

It indicates the temperature set for Freezer Compartment.

If the Flexi Zone Storage Compartment is set as a Freezer, then the temperature of the Flexi Zone Storage Compartment will change as -18, -20, -22, -24, -18... respectively each time you press this button.

If the Flexi Zone Compartment is set as a Fridge, then the temperature of the Flexi Zone Compartment will change as 10, 8, 6, 4, 2, 0, -6, ... respectively each time you press this button.

13. Flexi Zone Storage Compartment Temperature Indicator

Indicates the temperature set for Flexi Zone storage compartment.

14. Quick Cool Button

Press this button briefly to activate the Quick Cool function. Press this button again to deactivate the selected function.

15. Fridge Compartment Temperature Indicator

Indicates the temperature set for Fridge Compartment.

16. Quick Cool Function Indicator

Indicates that the Quick Cool function is active. Use this function when you place fresh food into the fridge compartment or when you need to cool your food quickly.

When this function is active, your refrigerator will run for 2 hours without stopping.

Press the relevant button again to deactivate this function.

Egg tray

- You can install the egg holder to the desired door or body shelf.
- Never store the egg holder in the freezer compartment.

Sliding Body Shelves

Sliding body shelves can be pulled by slightly lifting up from the front and moved back and forth. They come to a stop point when pulled towards front to allow you reach the foods placed at the back of the shelf; when it is pulled after slightly lifting upwards at the second stop point, the body shelf will be released.

The shelf should be held tightly from the bottom as well in order to prevent it from tipping over. The body shelf is placed on the rails at the sides of the refrigerator body by bringing it to one lower or one upper level.

The body shelf should be pushed backwards to seat it completely.

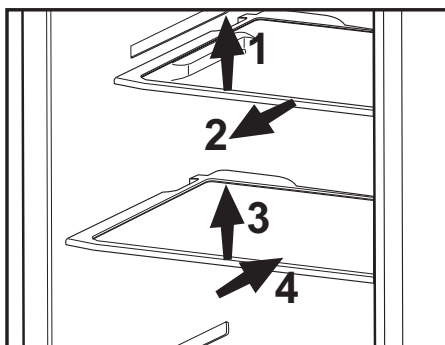

Crisper

Crisper of your refrigerator is designed specially to keep your vegetables freshly without losing their humidity. For this purpose, cool air circulation occurs around the crisper in general.

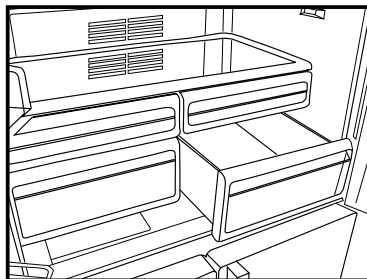

Chiller compartment

Chiller compartments enable the foods to be frozen become ready for freezing. You can also use these compartments to store your food at a temperature a few degrees below the fridge compartment.

You can increase the inner volume of your refrigerator by removing any of the chiller compartments. To do this, pull the compartment towards yourself; the compartment will lean against the stopper and stop. This compartment will be released when you lift it about 1 cm and pull it towards yourself.

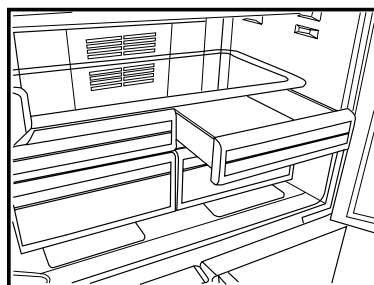

Rotating Middle Section

Rotating middle section is intended to prevent the cold air inside your refrigerator from escaping outside. Rotating middle section aids in sealing since the gaskets on the door presses on the surface of the Rotating middle section when the doors of the fridge compartment are closed. Another reason that your refrigerator is equipped with a rotating middle section is that it increases the net volume of the fridge compartment. Standard middle sections occupy some non-usable volume in the refrigerator.

The rotating middle section must be closed while the left door of the fridge compartment is open. It must not be opened manually, it is rotating by means of a plastic part mounted on the cabinet.

Multi Zone Storage Compartment

The Multi Zone Storage Compartment of your refrigerator may be used in any desired mode by adjusting it to fridge (2/4/6/8 °C) or freezer (-18/-20/-22/-24) temperatures. You can keep the compartment in the desired temperature with the Multi Zone Storage Compartment Temperature Setting Button. The temperature of the Multi Zone Storage Compartment may be set to 0 and 10 degrees in addition to the fridge compartment temperatures and to -6 degrees in addition to the freezer compartment temperatures. 0 degree is used to store the deli products longer, and -6 degrees is used to keep the meats

up to 2 weeks in an easily cuttable condition.

i The feature of switching to a Fridge or Freezer compartment is provided by a cooling element located in the closed section (Compressor Compartment) behind the refrigerator. During operation of this element, sounds similar to the sound of seconds heard from an analog clock may be heard. This is normal and is not fault cause.

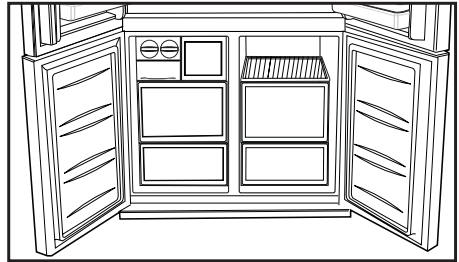

Blue light

Foodstuff stored in the crispers that are enlightened with a blue light continue their photosynthesis by means of the wavelength effect of blue light and thus, preserve their freshness and increase their vitamin content.

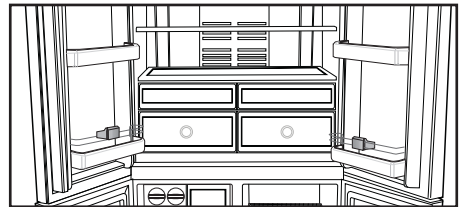

6 Maintenance and cleaning

- ⚠ Never use gasoline, benzene or similar substances for cleaning purposes.
- ⚠ We recommend that you unplug the appliance before cleaning.
- ❗ Never use any sharp abrasive instrument, soap, household cleaner, detergent and wax polish for cleaning.
- ❗ Use lukewarm water to clean the cabinet of your refrigerator and wipe it dry.
- ❗ Use a damp cloth wrung out in a solution of one teaspoon of bicarbonate of soda to one pint of water to clean the interior and wipe it dry.
- ⚠ Make sure that no water enters the lamp housing and other electrical items.
- ⚠ If your refrigerator is not going to be used for a long period of time, unplug the power cable, remove all food, clean it and leave the door ajar.
- ❗ Check door seals regularly to ensure they are clean and free from food particles.
- ❗ To remove door racks, remove all the contents and then simply push the door rack upwards from the base.

Protection of plastic surfaces

- ❗ Do not put the liquid oils or oil-cooked meals in your refrigerator in unsealed containers as they damage the plastic surfaces of your refrigerator. In case of spilling or smearing oil on the plastic surfaces, clean and rinse the relevant part of the surface at once with warm water.

7 Recommended solutions for the problems

Please review this list before calling the service. It might save you time and money. This list includes frequent complaints that are not arising from defective workmanship or material usage. Some of the features described here may not exist in your product.

The refrigerator does not operate
<ul style="list-style-type: none">• Is the refrigerator properly plugged in? Insert the plug to the wall socket.• Is the fuse of the socket which your refrigerator is connected to or the main fuse blown out? Check the fuse.
Condensation on the side wall of the fridge compartment. (MULTI ZONE, COOL CONTROL ve FLEXI ZONE)
<ul style="list-style-type: none">• Very cold ambient conditions. Frequent opening and closing of the door. Highly humid ambient conditions. Storage of food containing liquid in open containers. Leaving the door ajar.• Switching the thermostat to a colder degree.• Decreasing the time the door left open or using it less frequently.• Covering the food stored in open containers with a suitable material.• Wipe the condensation using a dry cloth and check if it persists.
Compressor is not running
<ul style="list-style-type: none">• Protective thermic of the compressor will blow out during sudden power failures or plug-out plug-ins as the refrigerant pressure in the cooling system of the refrigerator has not been balanced yet.• Your refrigerator will start running approximately after 6 minutes. Please call the service if your refrigerator does not startup at the end of this period.• The fridge is in defrost cycle. This is normal for a full-automatically defrosting refrigerator. Defrosting cycle occurs periodically.• Your refrigerator is not plugged into the socket. Make sure that the plug is inserted tightly to the wall socket.• Are the temperature adjustments correctly made? There is a power failure. Call your electricity supplier.
The fridge is running frequently or for a long time.

- Your new refrigerator may be wider than the previous one. This is quite normal. Large refrigerators operate for a longer period of time.
- The ambient room temperature may be high. This is quite normal.
- The refrigerator might have been plugged in recently or might have been loaded with food. Cooling down of the refrigerator completely may last for a couple of hours longer.
- Large amounts of hot food might have been put in the refrigerator recently. Hot food causes longer running of the refrigerator until they reach the safe storage temperature.
- Doors might have been opened frequently or left ajar for a long time. The warm air that has entered into the refrigerator causes the refrigerator to run for longer periods. Open the doors less frequently.
- Freezer or fridge compartment door might have been left ajar. Check if the doors are tightly closed.
- The refrigerator is adjusted to a very low temperature. Adjust the refrigerator temperature to a warmer degree and wait until the temperature is achieved.
- Door seal of the fridge or freezer may be soiled, worn out, broken or not properly seated. Clean or replace the seal. Damaged/broken seal causes the refrigerator to run for a longer period of time in order to maintain the current temperature.

Freezer temperature is very low while the fridge temperature is sufficient.

- The freezer temperature is adjusted to a very low temperature. Adjust the freezer temperature to a warmer degree and check.

Fridge temperature is very low while the freezer temperature is sufficient.

- The fridge temperature is adjusted to a very low temperature. Adjust the fridge temperature to a warmer degree and check.

Food kept in the fridge compartment drawers are freezing.

- The fridge temperature is adjusted to a very low temperature. Adjust the fridge temperature to a warmer degree and check.

Temperature in the fridge or freezer is very high.

- The fridge temperature is adjusted to a very high degree. Fridge adjustment has an effect on the temperature of the freezer. Change the temperature of the fridge or freezer until the fridge or freezer temperature reaches to a sufficient level.
- The door might be left ajar. Close the door completely.
- Large amounts of hot food might have been put in the refrigerator recently. Wait until the fridge or freezer reaches the desired temperature.
- Refrigerator might have been plugged in recently. Cooling down of the refrigerator completely takes time because of the size.

Noise similar to the sound of seconds heard from an analog clock is coming from the refrigerator.

<ul style="list-style-type: none"> • This noise is coming from the solenoid valve of the refrigerator. Solenoid valve functions for the purpose of ensuring coolant passage through the compartment which can be adjusted to cooling or freezing temperatures, and performing cooling functions. This is normal and is not fault cause.
The operation noise increases when the refrigerator is running.
<ul style="list-style-type: none"> • The operating performance characteristics of the refrigerator may change according to the changes in the ambient temperature. It is normal and not a fault.
Vibrations or noise.
<ul style="list-style-type: none"> • The floor is not even or it is weak. The refrigerator rocks when moved slowly. Make sure that the floor is level, strong and capable to carry the refrigerator. • The noise may be caused by the items put onto the refrigerator. Such items should be removed from the top of the refrigerator.
There are noises like liquid spilling or spraying.
<ul style="list-style-type: none"> • Liquid and gas flows happen in accordance with the operating principles of your refrigerator. It is normal and not a fault.
There is a noise like wind blowing.
<ul style="list-style-type: none"> • Air activators (fans) are used in order to allow the refrigerator to cool efficiently. It is normal and not a fault.
Condensation on the inner walls of refrigerator.
<ul style="list-style-type: none"> • Hot and humid weather increases icing and condensation. It is normal and not a fault. • The doors are ajar. Make sure that the doors are closed completely. • Doors might have been opened very frequently or they might have been left open for along time. Open the door less frequently.
Humidity occurs on the outside of the refrigerator or between the doors.
<ul style="list-style-type: none"> • The weather may be humid. This is quite normal in humid weather. When the humidity is less, condensation will disappear.
Bad odor inside the refrigerator.
<ul style="list-style-type: none"> • Inside of the refrigerator must be cleaned. Clean the inside of the refrigerator with a sponge, warm water or carbonated water. • Some containers or packaging materials might be causing the smell. Use a different container or different brand packaging material.
The door(s) is (are) not closing.
<ul style="list-style-type: none"> • Food packages may prevent the door's closing. Replace the packages that are obstructing the door. • The refrigerator is probably not completely vertical on the floor and it might be rocking when slightly moved. Adjust the elevation screws. • The floor is not level or strong. Make sure that the floor is level and capable to carry the refrigerator.
Crispers are stuck.
<ul style="list-style-type: none"> • The food might be touching the ceiling of the drawer. Rearrange food in the drawer.

Built-in Product Dimensions - 4 Doors

SIDE BY SIDE REFRIGERATOR INSTALLATION INSTRUCTIONS

If you want to install your product inside the kitchen furniture, adjust the furniture dimensions in accordance with the following measures.

- Provide an opening of min. 50 mm between the wall and the product so that the cooling performance of the product will not decrease.
- As the water inlet is at the rear side of the refrigerator for products equipped with water dispenser, make sure that the hose is not kinked or squeezed.
- Plug your refrigerator always into a grounded socket. Pay attention not to damage the power cable during transportation.
- Do not place devices such as radiators, heaters and etc. close to the refrigerator.

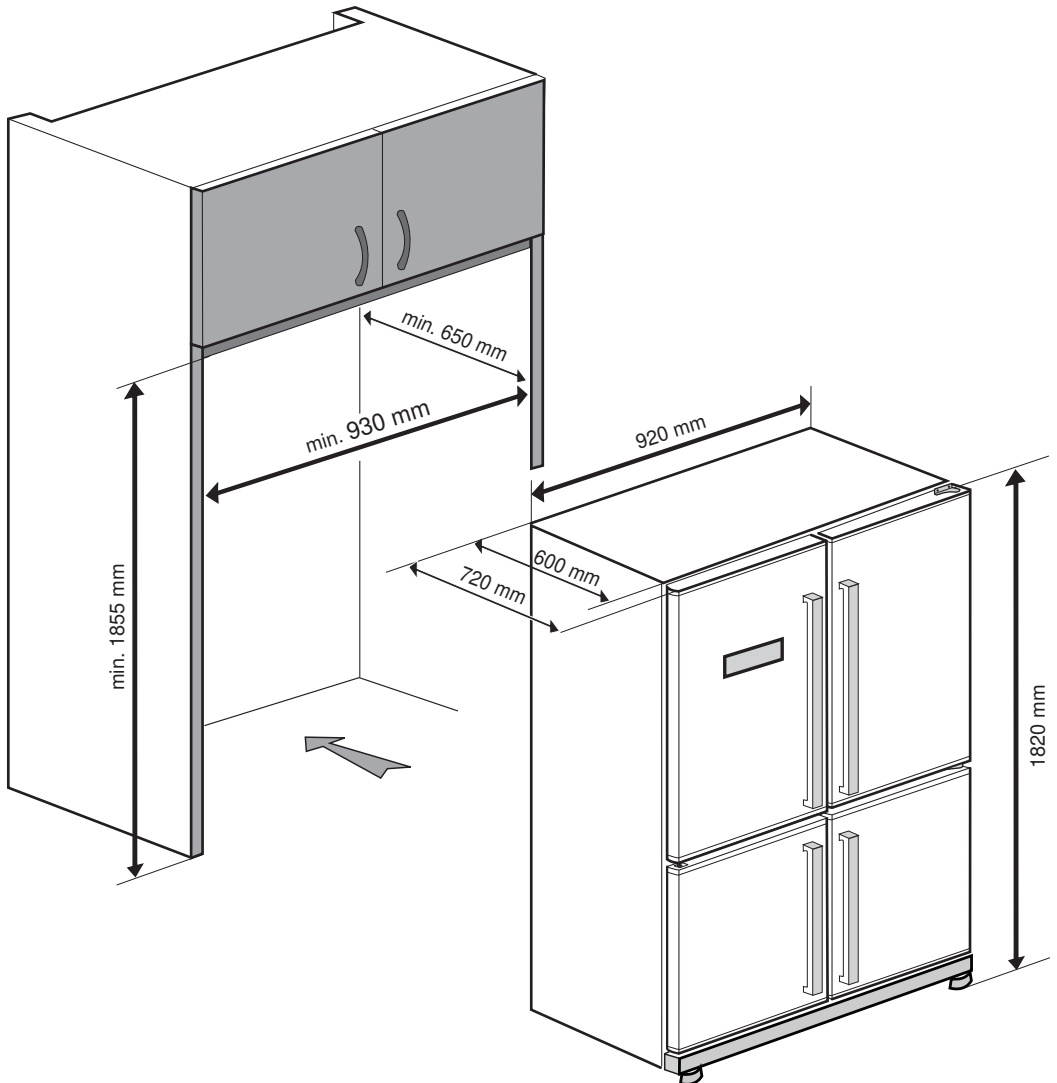

Overall space required in use - 4 Door

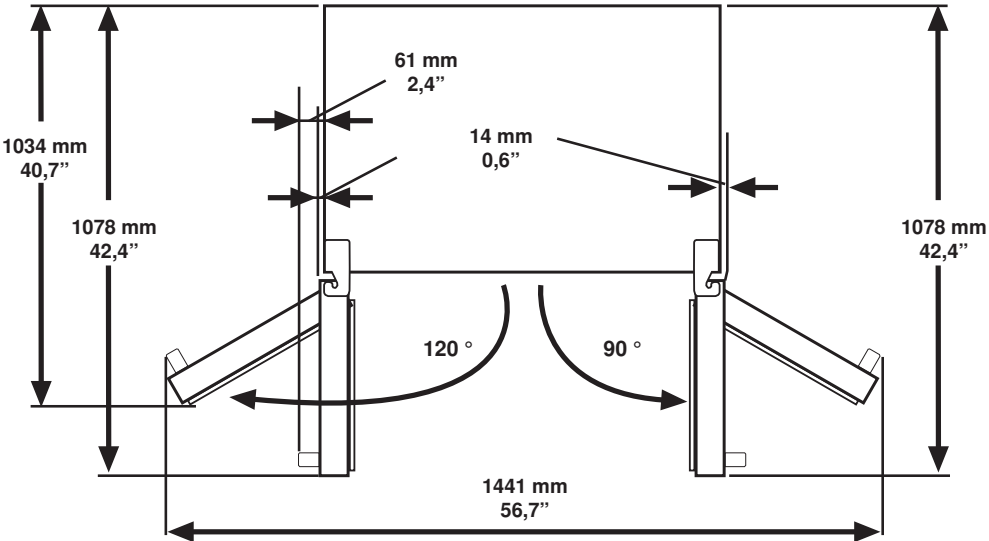

48 9827 0000/AB

EN-IT-PT-NL-FR-SV-DA-ES-RU-DE