

AINSLEY PLAY SYSTEM – F24145

INSTALLATION AND OPERATING INSTRUCTIONS

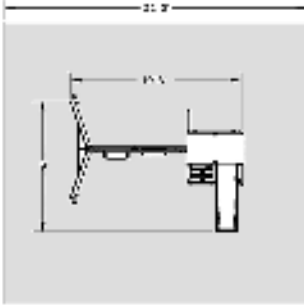

! WARNING To reduce the risk of serious injury or death, you must read and follow these instructions. Keep and refer to these instructions often and give them to any future owner of this play system. Manufacturer contact information provided below.

OBSTACLE FREE SAFETY ZONE - 22'3" x 28' area requires Protective Surfacing. See page 3.

MAXIMUM VERTICAL FALL HEIGHT - 6' (1.8 m)

CAPACITY - 6 Users Maximum, Ages 3 to 10; Weight Limit 110 lbs. (49.9 kg) per child.

RESIDENTIAL HOME USE ONLY. Not intended for public areas such as schools, churches, nurseries, day cares or parks.

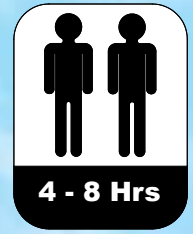

Two person assembly



Cedar Summit
c/o ©Solowave Design L.P.
Mount Forest, ON Canada
N0G 2L0

www.cedarsummitplay.com
support@cedarsummitplay.com
Customer Service
1-877-817-5682 (toll free)
1-519-323-2258

Table of Contents

Warnings and Safe Play Instructions.....	pg. 2
Protective Surfacing Guidelines.....	pg. 3
Instructions for Proper Maintenance.....	pg. 4
About Our Wood – Limited Warranty.....	pg. 5
Keys to Assembly Success.....	pg. 6
Part ID.....	pg. 7
Installation of I.D./Warning Plaque.....	Final Step

Warnings and Safe Play Instructions



CONTINUOUS ADULT SUPERVISION REQUIRED. Most serious injuries and deaths on playground equipment have occurred while children were unsupervised! Our products are designed to meet mandatory and voluntary safety standards. Complying with all warnings and recommendations in these instructions will reduce the risk of serious or fatal injury to children using this play system. Go over the warnings and safe play instructions regularly with your children and make certain that they understand and follow them. Remember on-site adult supervision is required for children of all ages.



WARNING

SERIOUS HEAD INJURY HAZARD

Installation over concrete, asphalt, dirt, grass, carpet and other hard surface creates a risk of serious injury or death from falls to the ground. Install and maintain shock absorbing material under and around play-set as recommended on page 3 of these instructions.

COLLISION HAZARD

Place play-set on level ground at least 6 feet from any obstruction such as a garage or house, fences, poles, trees, sidewalks, walls, landscape timbers, rocks, pavement, planters, garden borders, overhanging branches, laundry lines, and electrical wires. (See OBSTACLE FREE SAFETY ZONE on cover)

CHOKING HAZARD/SHARP EDGES & POINTS

Adult assembly required. This product contains small parts and parts with sharp edges and points. Keep parts away from children until fully assembled.

WARNING LABEL

Owners shall be responsible for maintaining the legibility of the warning labels.

STRANGULATION HAZARD

- NEVER allow children to play with ropes, clotheslines, pet leashes, cables, chains or cord-like items when using this play-set or to attach these items to play-set.
- NEVER allow children to wear loose fitting clothing, ponchos, hoods, scarves, capes, necklaces, items with draw-strings, cords or ties when using this play-set.
- NEVER allow children to wear bike or sport helmets when using this play-set.

Failure to prohibit these items, even helmets with chin straps, increases the risk of serious injury and death to children from entanglement and strangulation.

TIP OVER HAZARD

Choose a level location for the equipment. This can reduce the likelihood of the play set tipping over and loose-fill surfacing materials washing away during heavy rains.

DO NOT allow children to play on the play-set until the assembly is complete and the unit is properly anchored.



WARNING – Safe Play Instructions

- ✓ Observe capacity limitations of your play-set. See front cover.
- ✓ Dress children with well fitting and full foot enclosing footwear.
- ✓ Teach children to sit with their full weight in the center of the swing seat to prevent erratic swing motion or falling off.
- ✓ Check for splintered, broken or cracked wood; missing, loose, or sharp edged hardware. Replace, tighten and or sand smooth as required prior to playing.
- ✓ Verify that suspended climbing ropes, rope ladders, chain or cable are secured at both ends and cannot be looped back on itself as to create an entanglement hazard.
- ✓ On sunny and or hot days, check the slide and other plastic rides to assure that they are not very hot as to cause burns. Cool hot slide and rides with water and wipe dry prior to using.
- ✗ Do not allow children to wear open toe or heel footwear like sandals, flip-flops or clogs.
- ✗ Do not allow children to walk, in front, between, behind or close to moving rides.
- ✗ Do not let children twist swing chains or ropes or loop them over the top support bar. This may reduce the strength of the chain or rope and cause premature failure.
- ✗ Do not let children get off rides while they are in motion.
- ✗ Do not permit climbing on equipment when it is wet.
- ✗ Do not permit rough play or use of equipment in a manner for which it was not intended. Standing on or jumping from the roof, elevated platforms, swings, climbers, ladders or slide can be dangerous.
- ✗ Do not allow children to swing empty rides or seats.
- ✗ Do not allow children to go down slide head first or run up slide.

⚠️ Protective Surfacing - Reducing Risk of Serious Head Injury From Falls.

One of the most important things you can do to reduce the likelihood of serious head injuries is to install shock-absorbing protective surfacing under and around your play equipment. The protective surfacing should be applied to a depth that is suitable for the equipment height in accordance with ASTM F1292. There are different types of surfacing to choose from; whichever product you select, follow these guidelines:

Loose-Fill Materials

- Maintain a minimum depth of 9 inches of loose-fill materials such as wood mulch/chips, engineered wood fiber (EWF), or shredded/recycled rubber mulch for equipment up to 8 feet high; and 9 inches of sand or pea gravel for equipment up to 5 feet high. NOTE: An initial fill level of 12 inches will compress to about a 9-inch depth of surfacing over time. The surfacing will also compact, displace, and settle, and should be periodically raked and refilled to maintain at least a 9-inch depth.
- Use a minimum of 6 inches of protective surfacing for play equipment less than 4 feet in height. If maintained properly, this should be adequate. (At depths less than 6 inches, the protective material is too easily displaced or compacted.)

NOTE: Do not install home playground equipment over concrete, asphalt, or any other hard surface. A fall onto a hard surface can result in serious injury to the equipment user. Grass and dirt are not considered protective surfacing because wear and environmental factors can reduce their shock absorbing effectiveness. Carpeting and thin mats are not adequate protective surfacing. Ground level equipment -- such as a sandbox, activity wall, playhouse or other equipment that has no elevated play surface -- does not need any protective surfacing.

- Use containment, such as digging out around the perimeter and/or lining the perimeter with landscape edging. Don't forget to account for water drainage.
- Periodically rake, check and maintain the depth of the loose-fill surfacing material. Marking the correct depth on the play equipment support posts will help you to see when the material has settled and needs to be raked and or replenished. Be sure to rake and evenly redistribute the surfacing in heavily used areas.
- Do not install loose fill surfacing over hard surfaces such as concrete or asphalt.

Poured-In-Place Surfaces or Pre-Manufactured Rubber Tiles

You may be interested in using surfacing other than loose-fill materials - like rubber tiles or poured-in-place surfaces.

- Installations of these surfaces generally require a professional and are not "do-it yourself" projects.
- Review surface specifications before purchasing this type of surfacing. Ask the installer/manufacture for a report showing that the product has been tested to the following safety standard: ASTM F1292 *Standard Specification for Impact Attenuation of Surfacing Materials within the Use Zone of Playground Equipment*. This report should show the specific height for which the surface is intended to protect against serious head injury. This height should be equal to or greater than the fall height - vertical distance between a designated play surface (*elevated surface for standing, sitting, or climbing*) and the protective surfacing below - of your play equipment.
- Check the protective surfacing frequently for wear.

Placement

Proper placement and maintenance of protective surfacing is essential. Refer to diagram on front cover. Be sure to;

- Extend surfacing at least 6 feet from the equipment in all directions.
- For to-fro swings, extend protective surfacing in front of and behind the swing to a distance equal to twice the height of the top bar from which the swing is suspended.
- For tire swings, extend surfacing in a circle whose radius is equal to the height of the suspending chain or rope, plus 6 feet in all directions.

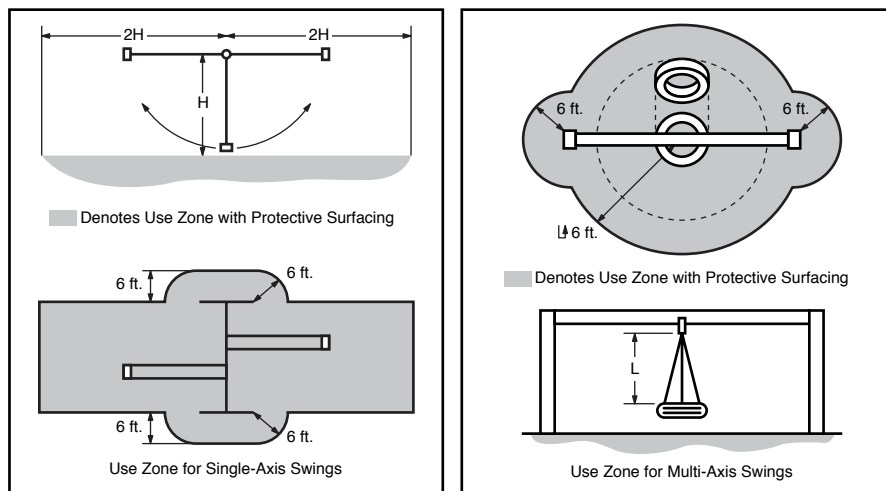

Instructions for Proper Maintenance

Your Cedar Summit Play System is designed and constructed of quality materials with your child's safety in mind. As with all outdoor products used by children, it will weather and wear. To maximize the enjoyment, safety and life of your Play Set, it is important that you, the owner, properly maintain it.

Check the following at the beginning of the play season:

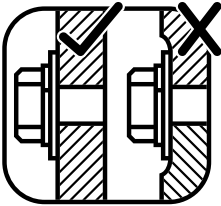
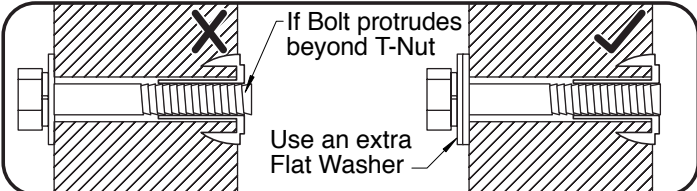
<p>HARDWARE:</p> <ul style="list-style-type: none"> ✓ Check metal parts for rust. If found, sand and repaint using a non-lead paint complying with 16 CFR 1303. ✓ Inspect and tighten all hardware. On wood assemblies DO NOT OVER-TIGHTEN as to cause crushing and splintering of wood. ✓ Check for sharp edges or protruding screw threads, add washers if required.  	<p>GROUND STAKES (ANCHORS):</p> <ul style="list-style-type: none"> ✓ Check for looseness, damage or deterioration. Should firmly anchor unit to ground during use. Re-secure and or replace, if necessary. <p>SWING HANGERS:</p> <ul style="list-style-type: none"> ✓ Check that bolts are secure and tight. Quick clips should be completely closed and threaded clips screwed tight. ✓ If squeaking occurs lubricate bushings with oil or WD-40®. <p>SWINGS, ROPES AND RIDES:</p> <ul style="list-style-type: none"> ✓ Reinstall if removed during cold season. Check all moving parts including swing seats, ropes, chains and attachments for wear, rust and other deterioration. Replace as needed. ✓ Check that ropes are tight, secure at both ends and cannot loop back as to create an entrapment. <p>WOOD PARTS:</p> <ul style="list-style-type: none"> ✓ Check all wood members for deterioration, structural damage and splintering. Sand down splinters and replace deteriorated wood members. As with all wood, some checking and small cracks in grain is normal. ✓ Unprotected, they will appear weathered over time. Periodic application of an exterior water repellent or stain (water-based) will help improve appearance and life.
<p>SHOCK ABSORBING SURFACING:</p> <ul style="list-style-type: none"> ✓ Check for foreign objects. Rake and check depth of loose fill protective surfacing materials to prevent compaction and maintain appropriate depth. Replace as necessary. (See Protective Surfacing, page 3) 	

Check twice a month during play season:

<p>HARDWARE:</p> <ul style="list-style-type: none"> ✓ Inspect for tightness. Must be firmly against, but not crushing the wood. DO NOT OVER-TIGHTEN. This will cause splintering of wood. ✓ Check for sharp edges or protruding screw threads. Add washers if required. 	<p>SHOCK ABSORBING SURFACING:</p> <ul style="list-style-type: none"> ✓ Rake and check depth of loose fill protective surfacing materials to prevent compaction and maintain appropriate depth. Replace as necessary. (See Protective Surfacing, page 3)
---	---

Check once a month during play season:

<p>SWING HANGERS:</p> <ul style="list-style-type: none"> ✓ Check that they are secure and orientated correctly. Hook should rotate freely and perpendicular to support beam. ✓ If squeaking occurs lubricate bushings with oil or WD-40®. 	<p>SWINGS AND RIDES:</p> <ul style="list-style-type: none"> ✓ Check swing seats, all ropes, chains and attachments for fraying, wear, excessive corrosion or damage. Replace if structurally damaged or deteriorated.
--	---

Check at the end of the play season:

<p>SWINGS AND RIDES:</p> <ul style="list-style-type: none"> ✓ To prolong their life, remove swings and store inside when outside temperature is below 32°F/0°C. Below freezing, plastic parts may become more brittle. 	<p>SHOCK ABSORBING SURFACING:</p> <ul style="list-style-type: none"> ✓ Rake and check depth of loose fill protective surfacing materials to prevent compaction and maintain appropriate depth. Replace as necessary. (See Protective Surfacing, page 3)
--	---

If you dispose of your play set: Please disassemble and dispose of your unit so that it does not create any unreasonable hazards at the time it is discarded. Be sure to follow your local waste ordinances.

About Our Wood

Cedar Summit Premium Play Systems uses only premium playset lumber, ensuring the safest product for your children's use. Although we take great care in selecting the best quality lumber available, wood is still a product of nature and susceptible to weathering which can change the appearance of your set.

What causes weathering? Does it affect the strength of my Play System?

One of the main reasons for weathering is the effects of water (moisture); the moisture content of the wood at the surface is different than the interior of the wood. As the climate changes, moisture moves in or out of the wood, causing tension which can result in checking and or warping. You can expect the following due to weathering. These changes will not affect the strength of the product:

1. **Checking** is surface cracks in the wood along the grain. A post (4" x 4") will experience more checking than a board (1" x 4") because the surface and interior moisture content will vary more widely than in thinner wood.
2. **Warping** results from any distortion (twisting, cupping) from the original plane of the board and often happens from rapid wetting and drying of the wood.
3. **Fading** happens as a natural change in the wood color as it is exposed to sun-light and will turn a grey over time.

How can I reduce the amount of weathering to my Play System?

At the factory we have coated the wood with a water repellent or stain. This coating decreases the amount of water absorption during rain or snow thus decreasing the tension in the wood. Sunlight will break down the coating, applying a water repellent or stain on a yearly basis is important maintenance. (see your local stain and paint supplier for a recommended product)

Most weathering is just the normal result of nature and will not affect safe play and enjoyment for your child. However if you are concerned that a part has experienced a severe weathering problem please call our consumer relations department for further assistance.

Complete and mail registration card to receive important product notifications and assure prompt warranty service.

5 Year Limited Warranty

Solowave Design warrants that this product is free from defect in materials and workmanship for a period of one year from the original date of purchase. In addition, lumber is warranted for 5 years against structural failure due to rot and insect damage. All other parts, such as hardware, swings, rides, accessories, and slides carry a one-year warranty only.

This warranty applies to the original owner and registrant and is non-transferable.

Regular maintenance is required to assure the integrity of your Play System. Failure by the owner to maintain the product according to the maintenance requirements may void this warranty. This warranty does not cover any inspection cost.

This Limited Warranty does not cover:

- Labor for replacement of any defective item(s);
- Incidental or consequential damages;
- Cosmetic defects which do not affect performance or integrity;
- Vandalism; improper use or installation; acts of nature;
- Minor twisting, warping, checking, or any other natural occurring properties of wood that do not affect performance or integrity.

Solowave Design products have been designed for safety and quality. Any modifications made to the original product could damage the structural integrity of the unit leading to failure and possible injury. Solowave Design Inc. cannot assume any responsibility for modified products. Furthermore, modification voids any and all warranties.

This product is warranted for **RESIDENTIAL USE ONLY**. Under no circumstance should a Solowave Design Play System be used in public settings such as schools, churches, playgrounds, parks, day cares and the like. Such use may lead to product failure and potential injury. Any and all public use will void this warranty.

Solowave Design disclaims all other representations and warranties of any kind, express or implied.

This Warranty gives you specific legal rights. You may have other rights as well which vary from state to state or province to province. This warranty excludes all consequential damages, however, some states do not allow the limitation or exclusion of consequential damages, and therefore this limitation may not apply to you.

Keys to Assembly Success

Tools Required

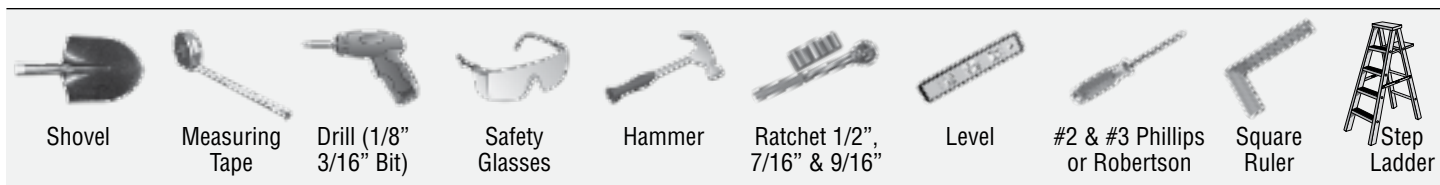

Part Identification Key

On each page, you will find the parts and quantities required to complete the assembly step illustrated on that page. Here is a sample.

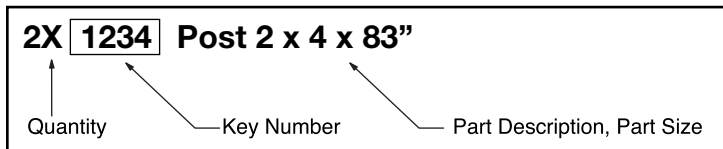

Symbols

Throughout these instructions symbols are provided as important reminders for proper and safe assembly.

<p>This identifies information that requires special attention. Improper assembly could lead to an unsafe or dangerous condition.</p>		<p>Check that set or assembly is properly level before proceeding.</p> <p>Use Level</p>
<p>Use Help</p>	<p>Use Help</p>	<p>Where this is shown, 2 or 3 people are required to safely complete the step. To avoid injury or damage to the assembly make sure to get help!</p>
<p>Measure Distance</p>	<p>Check that assembly is square before tightening bolts.</p>	<p>Tighten Bolts</p>
<p>Use a measuring tape to assure proper location.</p>	<p>Square Assembly</p>	<p>Pre-drill 1/8\"/> </p>
<p>Pre-drill a pilot hole before fastening screw or lag to prevent splitting of wood.</p>	<p>This indicates time to tighten bolts, but not too tight! Do not crush the wood. This may create splinters and cause structural damage.</p>	

CAUTION – Protrusion Hazard

Once the assembly is tightened, watch for exposed threads. If a thread protrudes from the T-Nut, remove the bolt and add washers to eliminate this condition. Extra washers have been provided for this purpose.

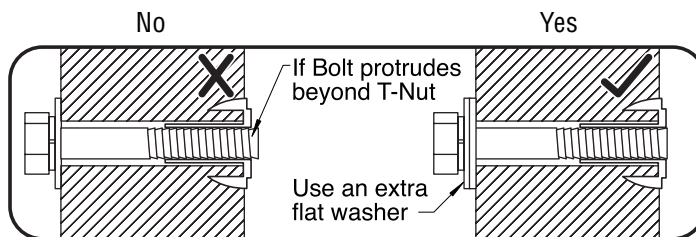

Proper Hardware Assembly

Lag screws require drilling pilot holes to avoid splitting wood. Only a flat washer is required. For ease of installation liquid soap can be used on all lag-type screws.

For bolts, tap T-Nut into hole with hammer. Insert the hex bolt through lock washer first then flat washer then hole. Because the assemblies need to be squared do not completely tighten until instructed. Pay close attention to diameter of the bolts. 5/16\"/>

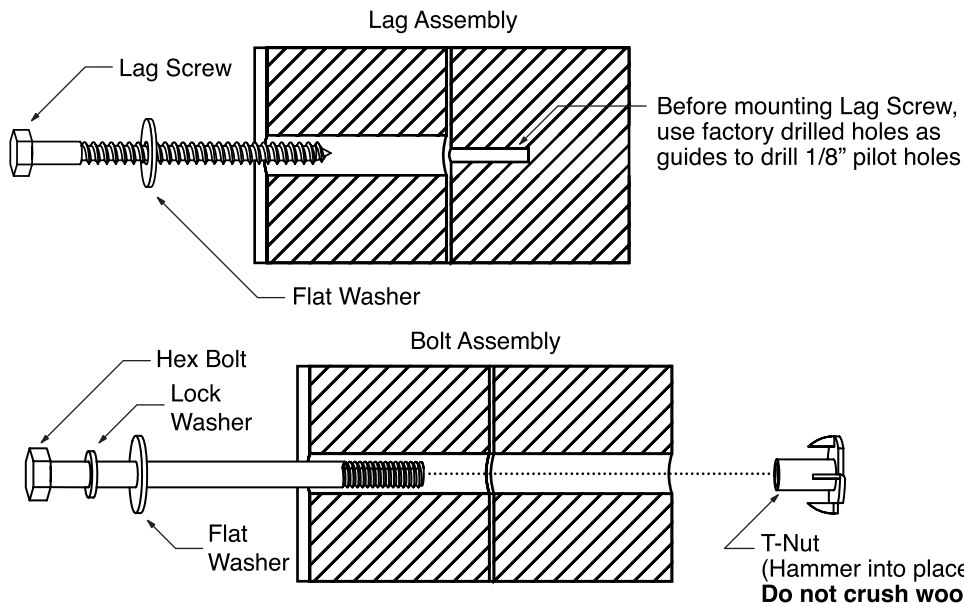

Part Identification (Reduced Size)

(5) CE Floor Board 1 x 4 x 32-1/2"



(1) CE SW Beam Back 2 x 6 x 69-1/2"



(1) CE SW Beam Front 2 x 6 x 69-1/2"



(2) CE Gap Board 1 x 6 x 23-1/2"



(5) Floor Board 1 x 6 x 23-1/2"

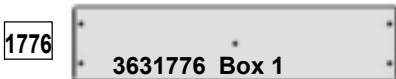

(2) CE Rock Board B 1 x 6 x 17"



(2) CE Rock Board A 1 x 6 x 17"

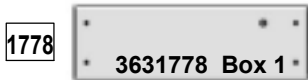

(1) CE Access Board 1 x 6 x 17"



(1) Gusset 2 x 3 x 16"



(2) Front Divider 1 x 4 x 38"

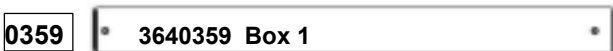

(1) Lower Diagonal 2 x 3 x 37"



(1) SW Top 1 x 4 x 26-7/8"

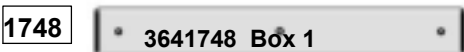

(2) SW Post 2 x 4 x 79-1/2"

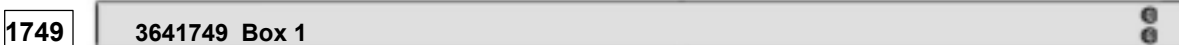

WOOD CHART	
Nominal Size	Actual Size
2" x 6"	1 1/2" x 5 3/8"
2" x 4"	1 3/8" x 3 3/8"
2" x 3"	1 3/8" x 2 1/2"
2" x 2"	1 1/2" x 1 1/2"
5/4" x 4"	1" x 3 1/2"
5/4" x 5"	1" x 4 1/2"
5/4" x 6"	1" x 5 1/2"
1" x 6"	5/8" x 5 3/8"
1" x 5"	5/8" x 4 1/2"
1" x 4"	5/8" x 3 3/8"
1" x 2"	5/8" x 1 3/8"

Part Identification (Reduced Part Size)

WOOD CHART	
Nominal Size	Actual Size
2" x 6"	1½" x 5¾"
2" x 4"	1¾" x 3¾"
2" x 3"	1¾" x 2½"
2" x 2"	1½" x 1½"
5/4" x 4"	1" x 3½"
5/4" x 5"	1" x 4½"
5/4" x 6"	1" x 5½"
1" x 6"	5/8" x 5¾"
1" x 5"	5/8" x 4½"
1" x 4"	5/8" x 3¾"
1" x 2"	5/8" x 1¾"

(1) Tarp Support 1 x 2 x 26-7/8"
3641750 Box 1



1750

(1) Centre Divider 2 x 2 x 38"
3641751 Box 1



1751

(1) Top Front 1 x 4 x 38-1/2"



1752

(1) Top End 1 x 4 x 26-7/8"

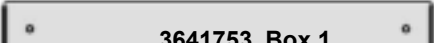

1753

(1) Lower Back Wall 1 x 4 x 31-1/2"



1754

(1) SW Support 5/4 x 4 x 40-1/2"



1755

(1) SW Upright 2 x 4 x 44"

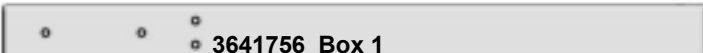

1756

(1) Wall Mount 2 x 4 x 40-3/4"

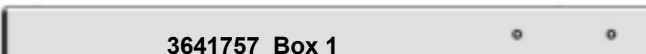

1757

(1) Top Back 1 x 4 x 38-1/2"

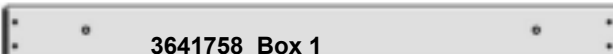

1758

(1) SW Floor 1 x 6 x 26-7/8"

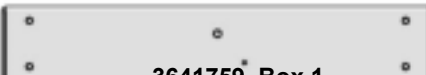

1759

(1) Floor 1 x 6 x 26-7/8"

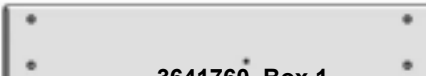

1760

(1) Side Joist 2 x 2 x 34-3/4"
3641761 Box 1



1761

(1) Floor Back 5/4 x 4 x 38-5/8"

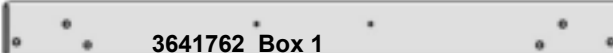

1762

Part Identification (Reduced Part Size)

(1) Floor Joist 5/4 x 2 x 38-1/2"
3641763 Box 1



(1) Floor Front 2 x 3 x 38-1/2"
3641764 Box 1

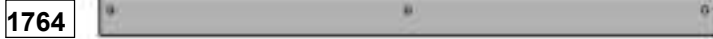

(2) Rock Rail 2 x 3 x 42-3/4"
3641765 Box 1



(3) Corner Block 2 x 3 x 4-1/2"



(1) Lower Front 1 x 6 x 39-3/4"



(1) Lower Back 1 x 5 x 38-1/2"

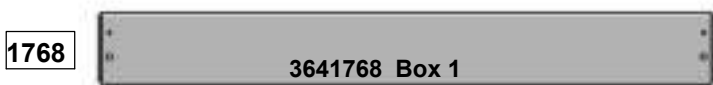

(1) Ground Side 1 x 5 x 42-1/4"

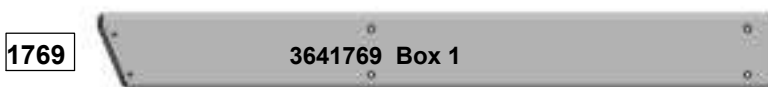

(1) SW Ground 1 x 5 x 60-1/4"



(4) Post 2 x 4 x 74"



(1) Sw Rail Block 2 x 4 x 5-3/8"



(4) Ground Stake 1-1/4 x 1-1/2 x 14"

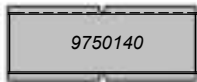

1X 3750140
Andorra Tarp Set



3750704



1X 3320550 (4pk)
Canopy Tube Holder -White



1X 3391267 (2pk)
Canopy Tube 1/2" x 67"



1X 9320357 Cedar
Summit I.D. Plaque



1X 3200184
Triangle Plate (4pk)
Green

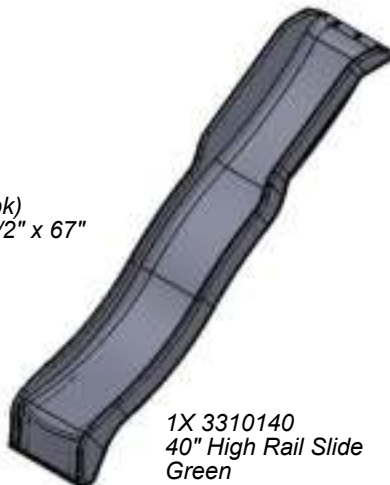

1X 3310140
40" High Rail Slide
Green



2X 3724943
Short Swing -Yellow

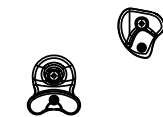

1X 3320184 Rocks (4pk)
4-Green

Hardware Identification (Actual Size)

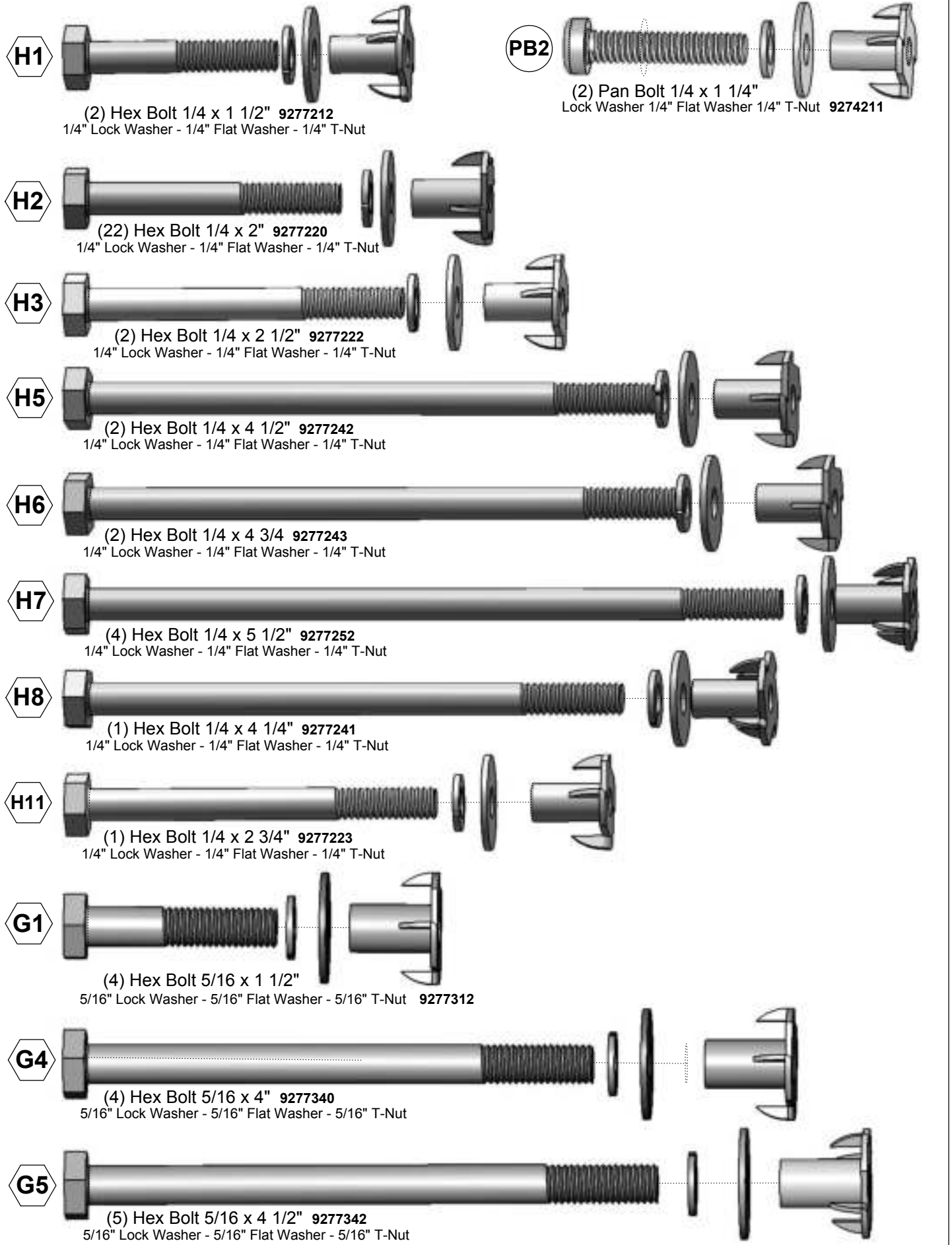

Hardware Identification (Actual Size)

G8 9277320
 (2) Hex Bolt 5/16 x 2"
 2-5/16" Flat Washer, 1- 5/16" Lock Nut

LS3 9262230
 (3) Lag Screw 1/4 x 3" -1/4" Flat Washer

S1
 (24) Flat Head Screw #8 x 1 1/8" (52042514)

S2
 (59) Flat Head Screw #8 x 1 1/2" (52042512)

S3
 (12) Flat Head Screw #8 x 2 1/2" (52042522)

S4
 (6) Flat Head Screw #8 x 3" (52042530)

S15
 (10) Pan Screw #8 x 1-3/4" (52042513)

S5
 (22) Pan Screw #8 x 1/2" (9264504)

S10
 (16) Pan Screw #8 x 1" (9264510)

S7
 (14) Pan Screw #12 x 2" (9264620)

(18)
 #8 Flat Washer
 (9251500)

(2)
 5/16" Lock Nut
 (9283300)

(12)
 3/16" Flat Washer
 (9251100)

(13)
 1/4" Lock Washer
 (9253200)

(38)
 1/4" Flat Washer
 (9251200)

(17)
 5/16" Flat Washer
 (9251300)

(38)
 1/4" T-Nut
 (9285200)

(13)
 5/16" T-Nut
 (9285300)

(1 pk of 4)
 Bolt Thru Swing
 Hangers
 (3202000)

First Step: Inventory Parts - Read This Before Starting Assembly

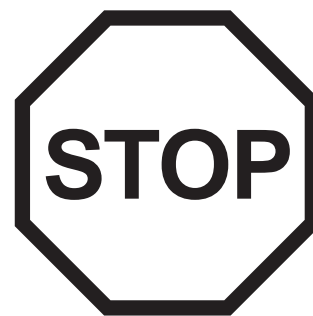
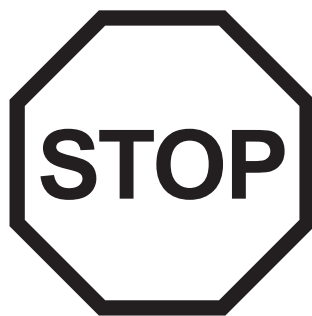
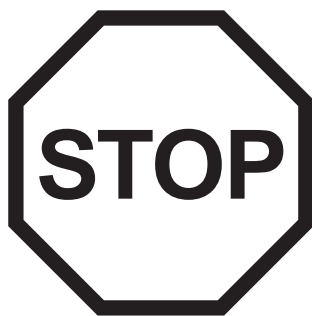
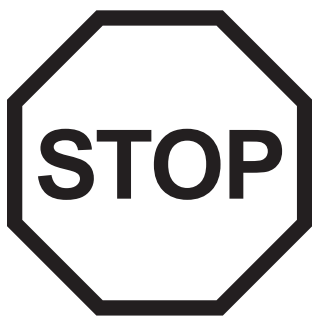

- A.** This is the time for you to inventory all your hardware, wood and accessories, referencing the parts identification sheets. This will assist you with your assembly.
- The wood pieces will have the four digit key number stamped on the ends of the boards. The wood pieces are referenced throughout the instructions with this number.
 - Please refer to Page 6 for proper hardware assembly.
 - Each step indicates which bolts and/or screws you will need for assembly, as well as any flat washers, lock washers, t-nuts or lock nuts.
- B.** If there are any missing or damaged pieces or you need assistance with assembly please contact the Consumer Relations Department directly. Call us before going back to the store.

1-877-966-3738
support@cedarsummitplay.com

- C.** Read the assembly manual completely, paying special attention to ANSI warnings; notes; and safety/maintenance information on pages 1 - 6.
- D.** Before you discard your cartons fill out the form below.
- The carton I.D. stamp is located on the end of each carton. The tracking number is located on the Big Backyard ID Plaque (3320356).
 - Please retain this information for future reference. You will need this information if you contact the Consumer Relations Department.

MODEL NUMBER: **F24145**

CARTON I.D. STAMP: _ _ _ _ 14459 _ (Box 1)

CARTON I.D. STAMP: _ _ _ _ 14459 _ (Box 4)

CARTON I.D. STAMP: _ _ _ _ 14459 _ (Box 2)

CARTON I.D. STAMP: _ _ _ _ 14459 _ (Box 5)

CARTON I.D. STAMP: _ _ _ _ 14459 _ (Box 3)

CARTON I.D. STAMP: _ _ _ _ 14459 _ (Box 6)

TRACKING NUMBER (from ID Plaque): _____

Step 1: Swing Beam Assembly

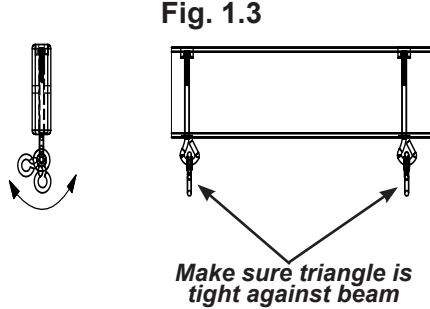
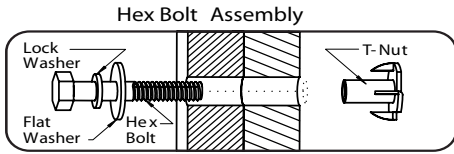
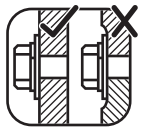

Warning: For your child's safety, orientate the swing hangers as shown to ensure your swing will have proper swing motion when installed. Failure to do so could result in premature failure of the swing hanger or swing chain.

A: In the middle holes of (1772) CE SW Beam Back install 2 Bolt Thru Swing Hangers making sure the swing hangers are oriented in the direction shown in fig. 1.3 to maintain proper swing motion.

B: In the end holes of (1773) CE SW Beam Front install 2 Bolt-Thru Swing Hangers making sure the swing hangers are oriented in the direction shown in fig. 1.3 to maintain proper swing motion.

C: Attach 1 (H7) 1/4 x 5-1/2" Hex Bolt (with lock washer, flat washer and t-nut) to the ends of each (1772) CE SW Beam Back and (1773) CE SW Beam Front. The bolts do not attach to anything, but **MUST** be installed to the beams to prevent splitting and checking of wood. (fig. 1.1)

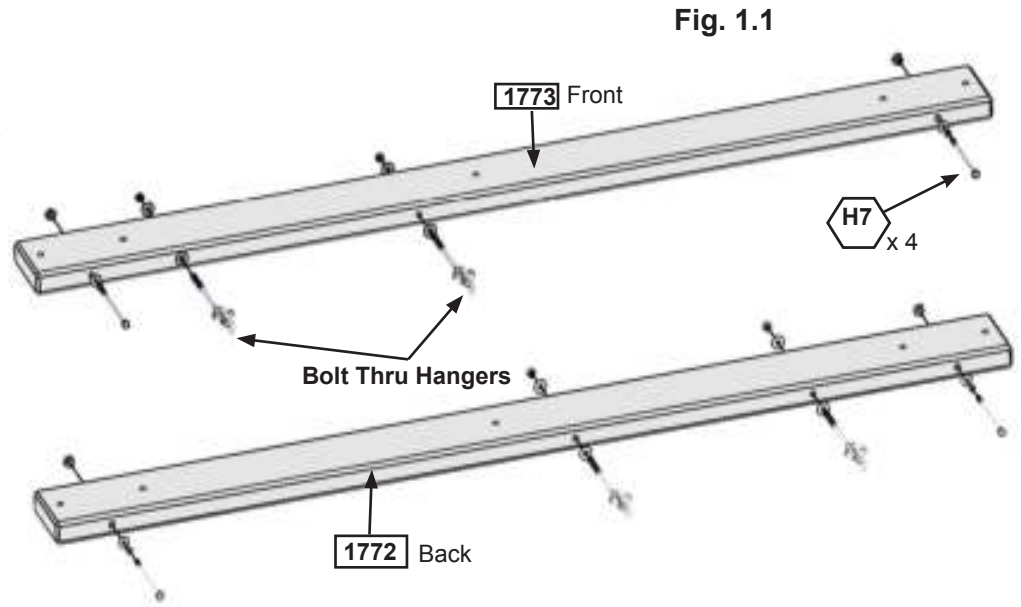

D: Attach 1 Triangle Plate to each end of both the (1773) CE SW Beam Front and (1772) CE SW Beam Back using 1 (G1) 5/16 x 1-1/2" Hex Bolt (with lock washer, flat washer and t-nut) per Triangle Plate in the hole indicated in fig. 1.2. **Correct hole usage is very important.** Refer to fig 1.2 for correct placement of Hex Bolts.

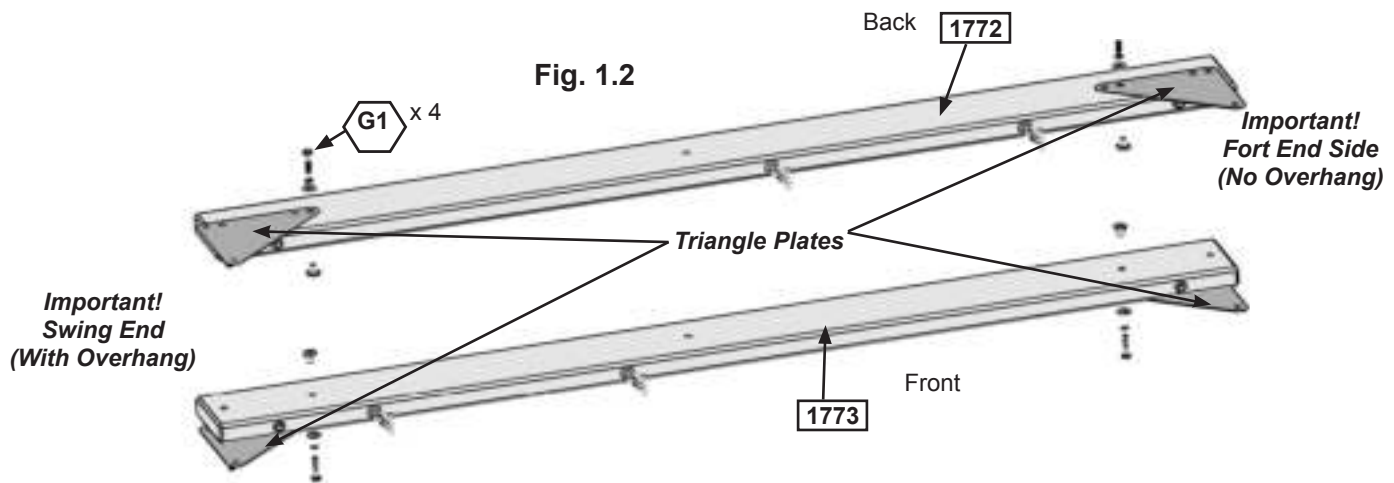

Wood Parts

- 1 x 1773 CE SW Beam Front 2 x 6 x 69-1/2"
- 1 x 1772 CE SW Beam Back 2 x 6 x 69-1/2"

Hardware

- 4 x G1 5/16 x 1-1/2" Hex Bolt (5/16" lock washer, 5/16" flat washer and 5/16" t-nut)
- 4 x H7 1/4 x 5-1/2" Hex Bolt (1/4" lock washer, 1/4" flat washer and 1/4" t-nut)

Other Parts

- 4 x Bolt Thru Swing Hangers
- 1 x Triangle Plates (pkg of 4)

Step 2: Swing End Assembly

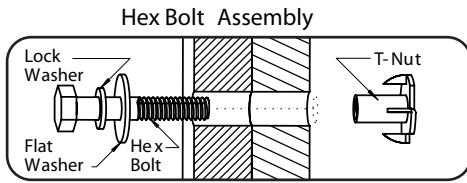
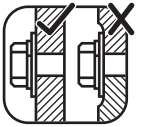

A: Attach 2 (1749) SW Posts to (1756) SW Upright using 2 (G4) 5/16 x 4" Hex Bolts (with lock washer, flat washer and t-nut). (fig. 2.1)

B: Attach (1755) SW Support to both (1749) SW Posts and (1756) SW Upright using 3 (G5) 5/16 x 4-1/2" Hex Bolts (with lock washer, flat washer and t-nut). (fig. 2.1)

Fig 2.1

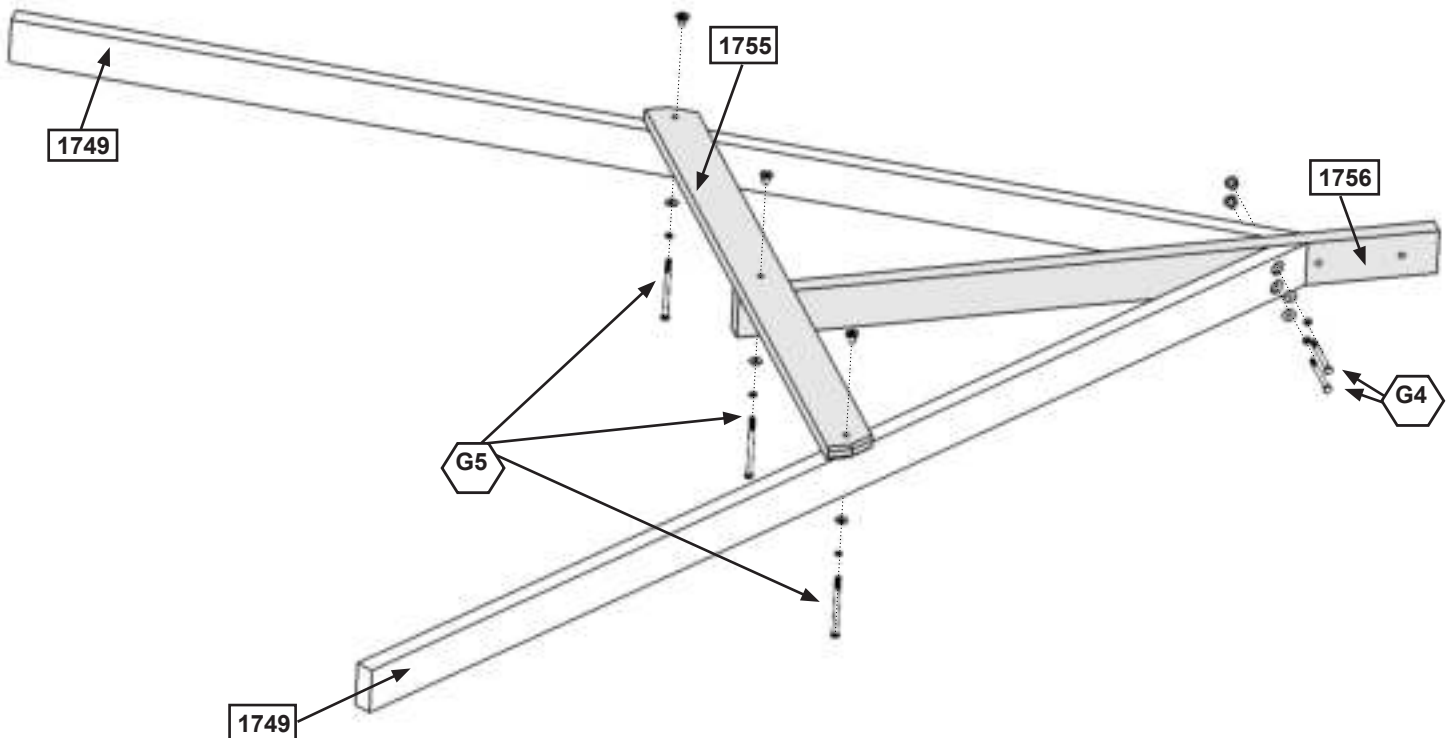

Wood Parts

- 2 x 1749 SW Post 2 x 4 x 79-1/2"
- 1 x 1756 SW Upright 2 x 4 x 44"
- 1 x 1755 SW Support 5/4 x 4 x 40-1/2"

Hardware

- 2 x G4 5/16 x 4" Hex Bolt
(5/16" lock washer, 5/16" flat washer, and 5/16" t-nut)
- 3 x G5 5/16 x 4-1/2" Hex Bolt
(5/16" lock washer, 5/16" flat washer, and 5/16" t-nut)

Step 3: Swing Beam

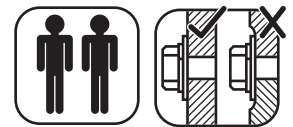

Hex Bolt Assembly

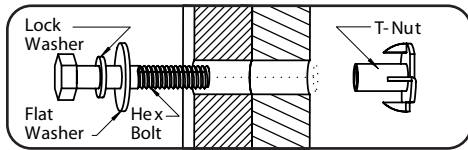

A: Place (4919) SW Rail Block in the centre between (1773) CE SW Beam Front and (1772) CE SW Beam Back and attach beams with 1 (H8) 1/4 x 4-1/4" Hex Bolt (with flat washer, lock washer and t-nut). (fig. 3.1 & 3.2)

B: Attach Swing Beam Assembly to the side of the Swing End Assembly with the overhang (fig. 3.3) using 1 (G5) 5/16 x 4-1/2" Hex Bolt (with lock washer, flat washer and t-nut) in the top hole of Triangle Plate and 1 (G8) 5/16 x 2" Hex Bolt (with 2 flat washers and lock nut) in the bottom hole of Triangle Plate. (fig. 3.3) Make sure Swing End Assembly flares out at an angle. (fig 3.4)

Fig. 3.1

Fig. 3.2

Fig. 3.3

Fig. 3.4

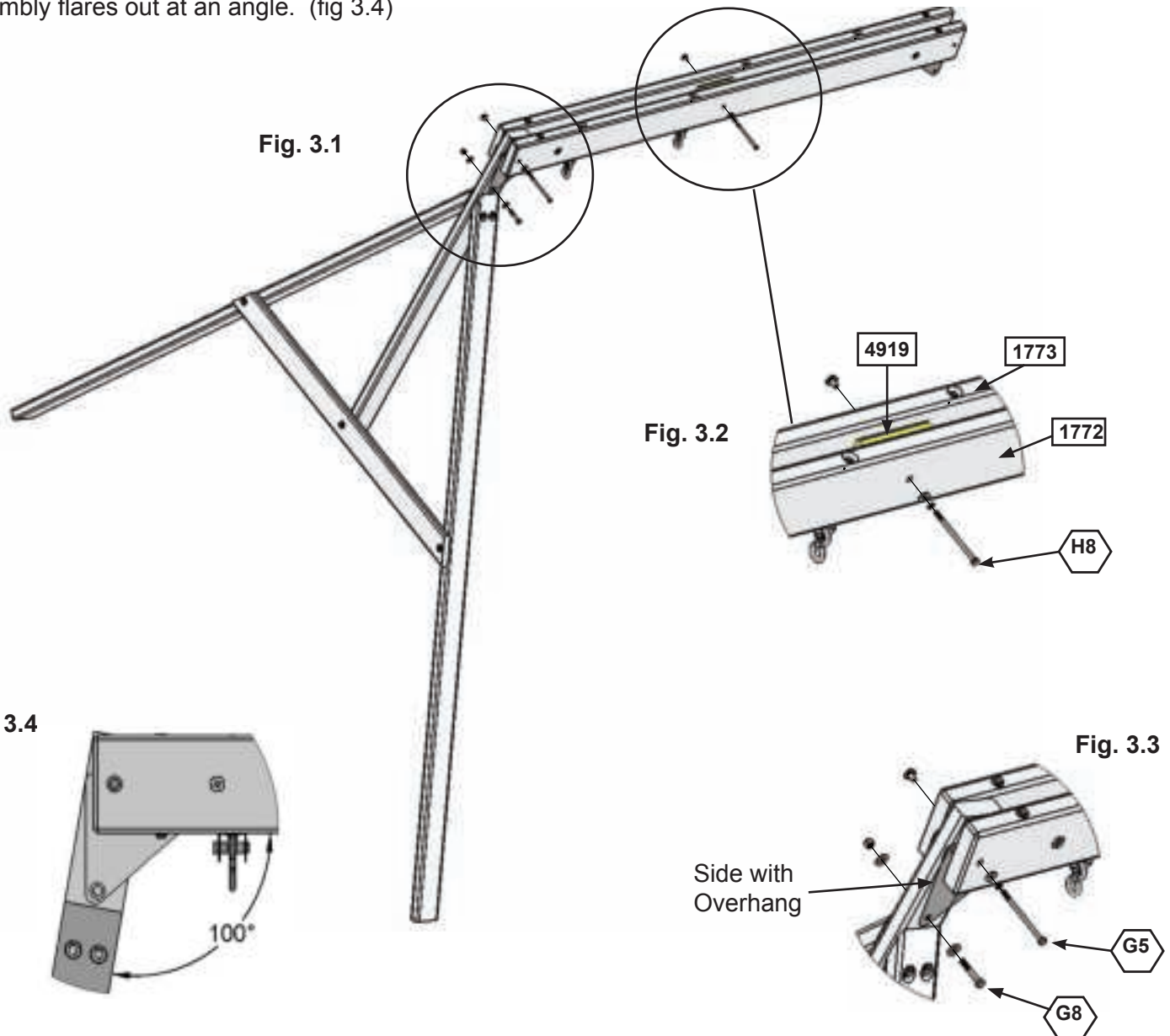

Wood Parts

1 x [4919] SW Rail Block 2 x 4 x 5-3/8"

Hardware

1 x [H8] 1/4 x 4-1/4" Hex Bolt (1/4" lock washer, 1/4" flat washer, 1/4" t-nut)

1 x [G5] 5/16 x 4-1/2" Hex Bolt (5/16" lock washer, 5/16" flat washer, 5/16" t-nut)

1 x [G8] 5/16 x 2" Hex Bolt (5/16" flat washer x 2, 5/16" lock nut)

Step 4: Swing Side Assembly

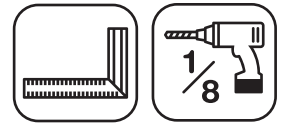

Note: Pre-drill all holes using a 1/8" drill bit before installing the lag screws.

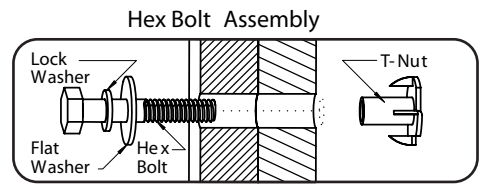
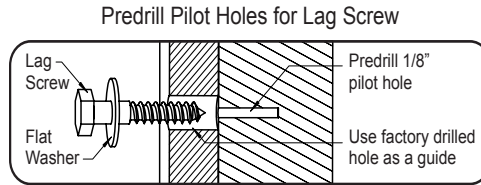

A: To 2 (1771) Posts attach (1770) SW Ground and (1759) SW Floor using 4 (H2) 1/4 x 2" Hex Bolts (with lock washer, flat washer and t-nut) in each board. **Be sure to keep bolts loose.** (fig. 4.1)

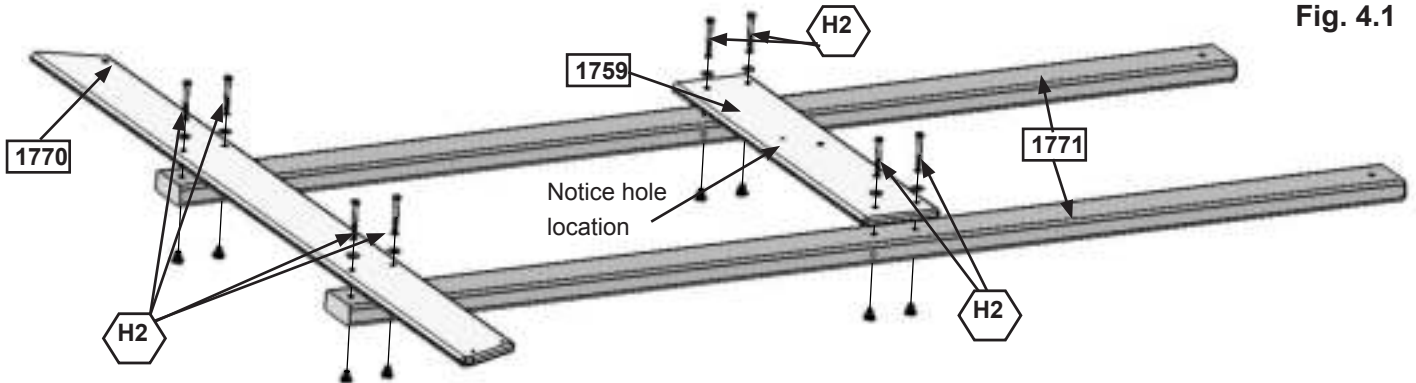

Fig. 4.1

B: Attach (1748) SW Top to each (1771) Post with 2 (H2) 1/4 x 2" Hex Bolts (with lock washer, flat washer and t-nut) Hex Bolts are to be installed from the back of the assembly. **Be sure to keep bolts loose.** (fig. 4.2)

C: Make sure assembly is square and then fasten (0369) Lower Diagonal to (1770) SW Ground at an angle using 1 (H2) 1/4 x 2" Hex Bolt (with lock washer, flat washer and t-nut) and to (1771) Post using 1 (LS3) 1/4 x 3" Lag Screw (with flat washer). (fig 4.2).

D: Attach (1757) Wall Mount to (1759) SW Floor and (1748) SW Top with 2 (G4) 5/16 x 4" Hex Bolts (with lock washer, flat washer and t-nut). (fig. 4.2)

E: Tighten all bolts.

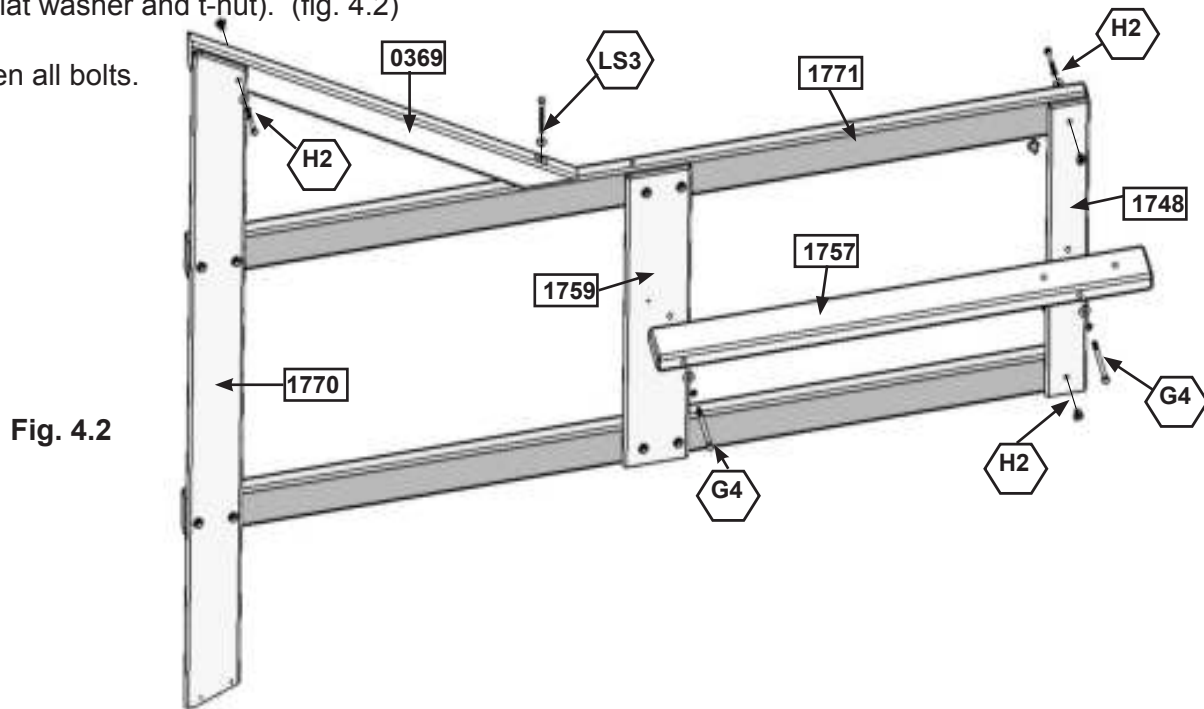

Fig. 4.2

Wood Parts

- 2 x 1771 Post 2 x 4 x 74"
- 1 x 1770 SW Ground 1 x 5 x 60-1/4"
- 1 x 1759 SW Floor 1 x 6 x 26-7/8"
- 1 x 0369 Lower Diagonal 2 x 3 x 37"
- 1 x 1757 Wall Mount 2 x 4 x 40-3/4"
- 1 x 1748 SW Top 1 x 4 x 26-7/8"

Hardware

- 11 x H2 1/4 x 2" Hex Bolt (1/4" lock washer, 1/4" flat washer, 1/4" t-nut)
- 2 x G4 5/16 x 4" Hex Bolt (5/16" lock washer, 5/16" flat washer, 5/16" t-nut)
- 1 x LS3 1/4 x 3" Lag Screw (with 1/4" flat washer)

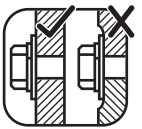

Step 5: Wall Side Assembly

Hex Bolt Assembly

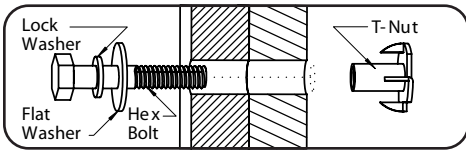

A: To 2 (1771) Posts attach (1760) Floor and (1769) Ground Side with 4 (H2) 1/4 x 2" Bolts (with lock washer, flat washer and t-nut) per board. (fig. 5.1)

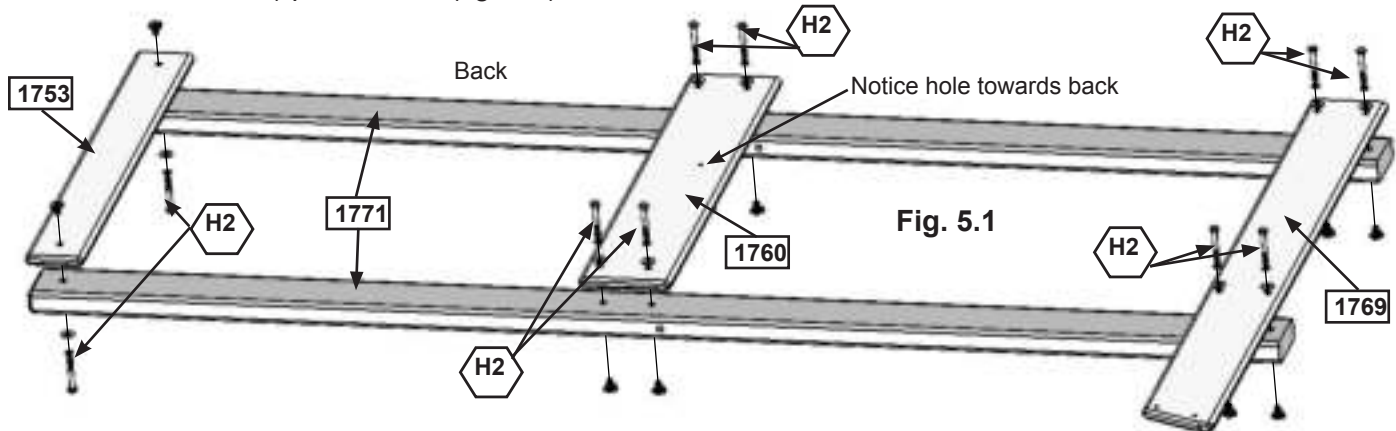

B: Attach (1753) Top End to each (1771) Post with 2 (H2) 1/4 x 2" Hex Bolts (with lock washer, flat washer and t-nut). These Hex Bolts are to be installed from the back of the assembly. (fig. 5.1)

C: Attach (1766) Corner Block flush to angled extension of (1769) Ground Side with 2 (S2) 8 x 1-1/2" Wood Screws as shown in fig. 5.2.

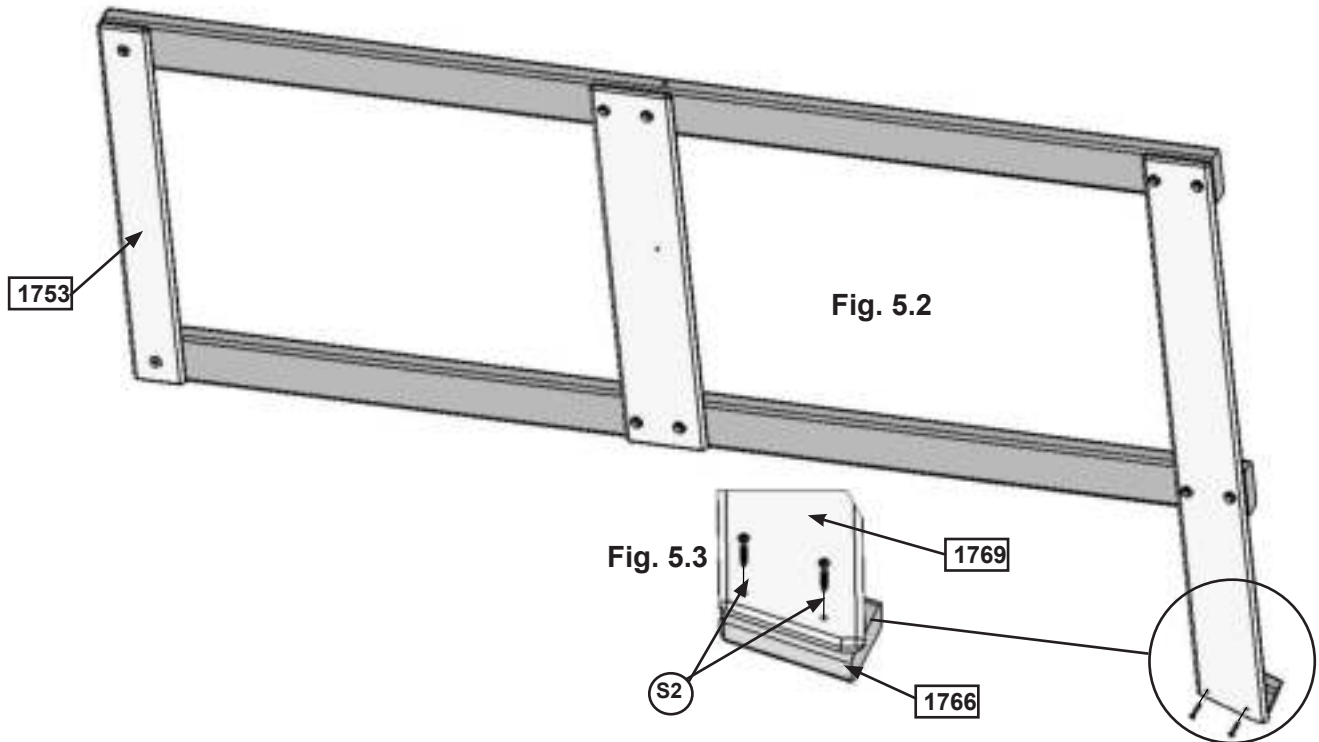

- Wood Parts**
- 2 x 1771 Post 2 x 4 x 74"
 - 1 x 1769 Ground Side 1 x 5 x 42-1/4"
 - 1 x 1760 Floor 1 x 6 x 26-7/8"
 - 1 x 1766 Corner Block 2 x 3 x 4-1/2"
 - 1 x 1753 Top End 1 x 4 x 26-7/8"

- Hardware**
- 10 x H2 1/4 x 2" Hex Bolt
(1/4" lock washer, 1/4" flat washer, 1/4" t-nut)
 - 2 x S2 #8 x 1-1/2" Wood Screw

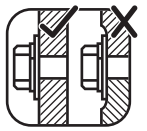

Step 6: Front Frame Assembly

Hex Bolt Assembly

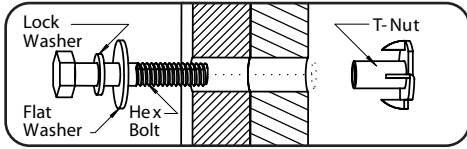

A: Attach (1764) Floor Front to (1771) Posts with 2 (H6) 1/4 x 4-3/4" Bolt (with flat washer, lock washer and t-nut). Hex Bolts to be installed from the inside of the assembly. (fig. 6.2)

B: Attach (1752) Top Front to (1771) Posts with 4 (S7) 12 x 2" Pan Screws (with 3/16" flat washer). (1752) Top Front should be flush to the top of each (1771) Post. (fig. 6.1 & 6.2)

Fig. 6.2

Notice hole towards top

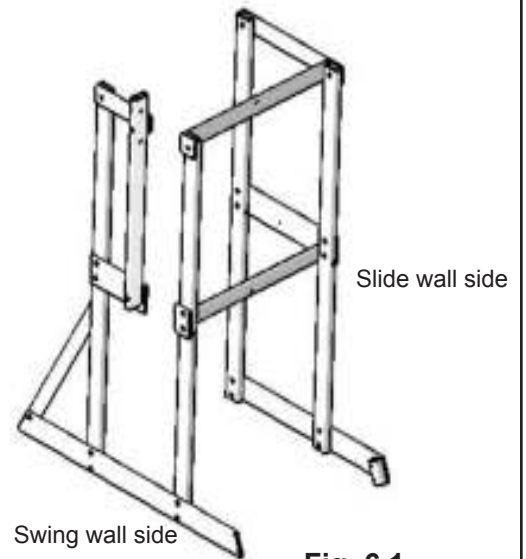
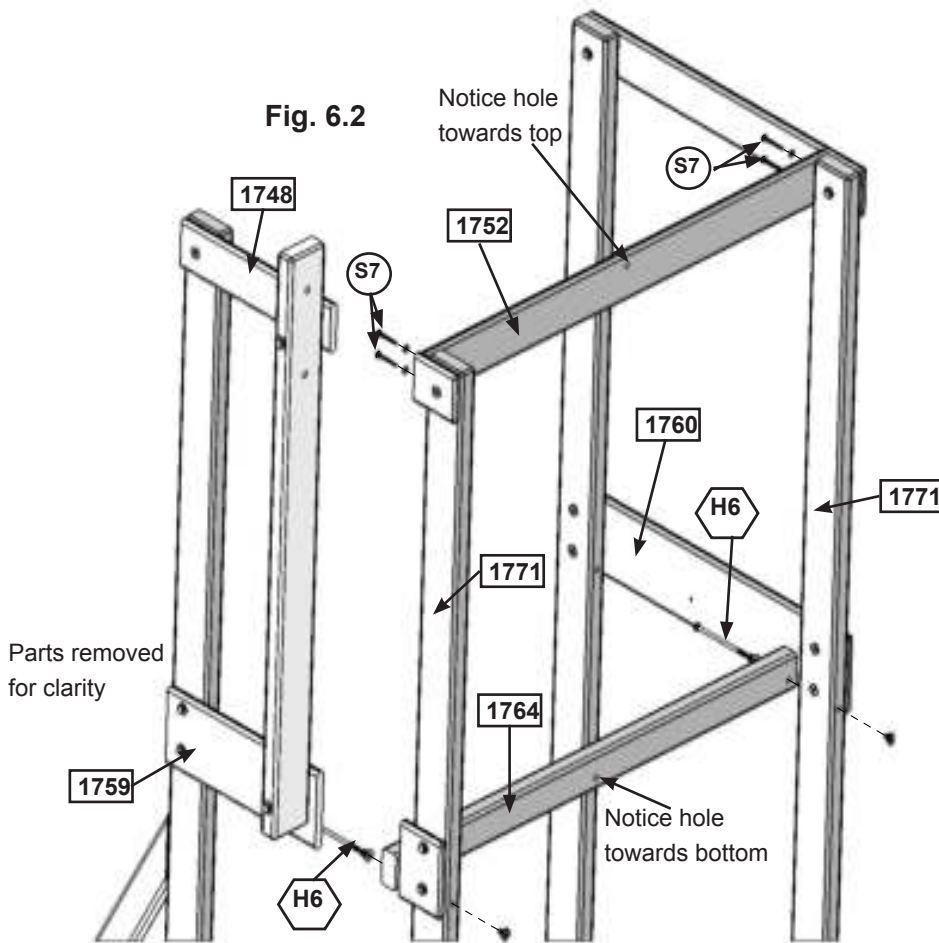

Fig. 6.1

Wood Parts

- 1 x 1764 Floor Front 2 x 3 x 38-1/2"
- 1 x 1752 Top Front 1 x 4 x 38-1/2"

Hardware

- 2 x H6 1/4 x 4-3/4" Hex Bolt (1/4" lock washer, 1/4" flat washer, 1/4" t-nut)
- 4 x S7 #12 x 2" Pan Screw (with 3/16" flat washer)

Step 7: Rock Rail Assembly



A: Attach (1766) Corner Block 1/2" from bottom of (1765) Rock Rail with 2 (S3) 8 x 2-1/2" Wood Screws as shown in fig. 7.1.

B: Make sure assembly is square and then attach (1765) Rock Rail with Corner Block to (1764) Floor Front with 2 (S15) #8 x 1-3/4" Wood Screws. Top of (1765) Rock Rail angled edge should be flush to the top of (1764) Floor Front. (fig. 7.2 & 7.3)

C: Attach (1770) SW Ground to (1765) Rock Rail with 2 (S2) #8 x 1-1/2" Wood Screws as shown in fig. 7.2 & 7.4.

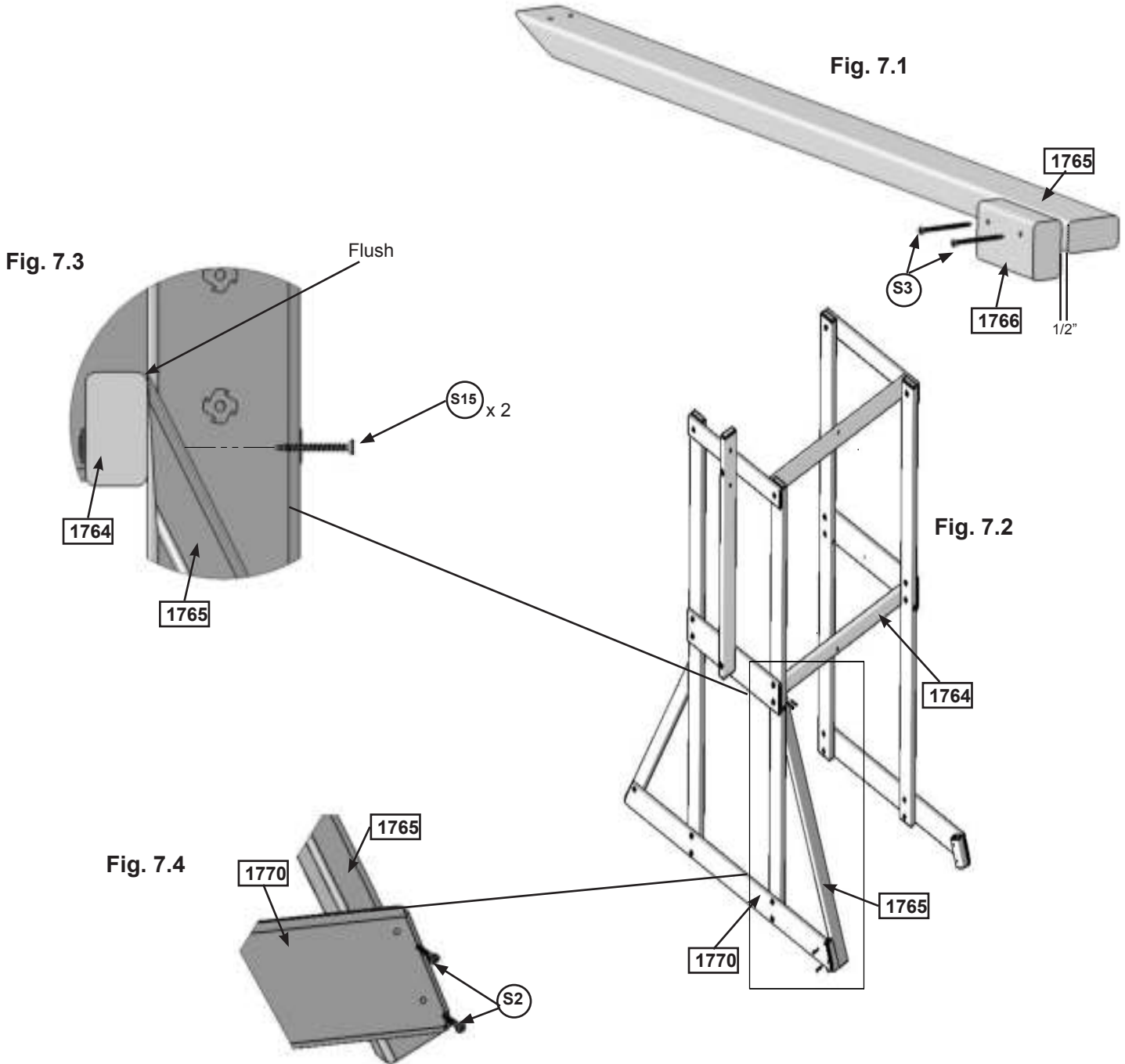

Wood Parts

- 1 x **1766** Corner Block 2 x 3 x 4-1/2"
- 1 x **1765** Rock Rail 2 x 3 x 42-3/4"

Hardware

- 2 x **(S3)** #8 x 2-1/2" Wood Screw
- 2 x **(S2)** #8 x 1-1/2" Wood Screw
- 2 x **(S15)** #8 x 1-3/4" Wood Screw



Step 8: Attach Centre Divider

Hex Bolt Assembly

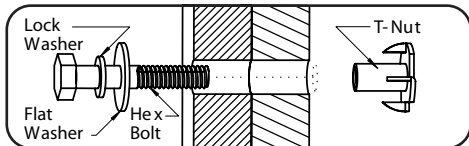

A: Attach (1751) Centre Divider to (1752) Top Front with 1 (H2) 1/4 x 2" Bolt (with flat washer, lock washer and t-nut) from outside of the assembly and to (1764) Floor Front with 1 (H11) 1/4 x 2-3/4" Bolt (with flat washer, lock washer and t-nut) from inside the assembly. (fig. 8.1)

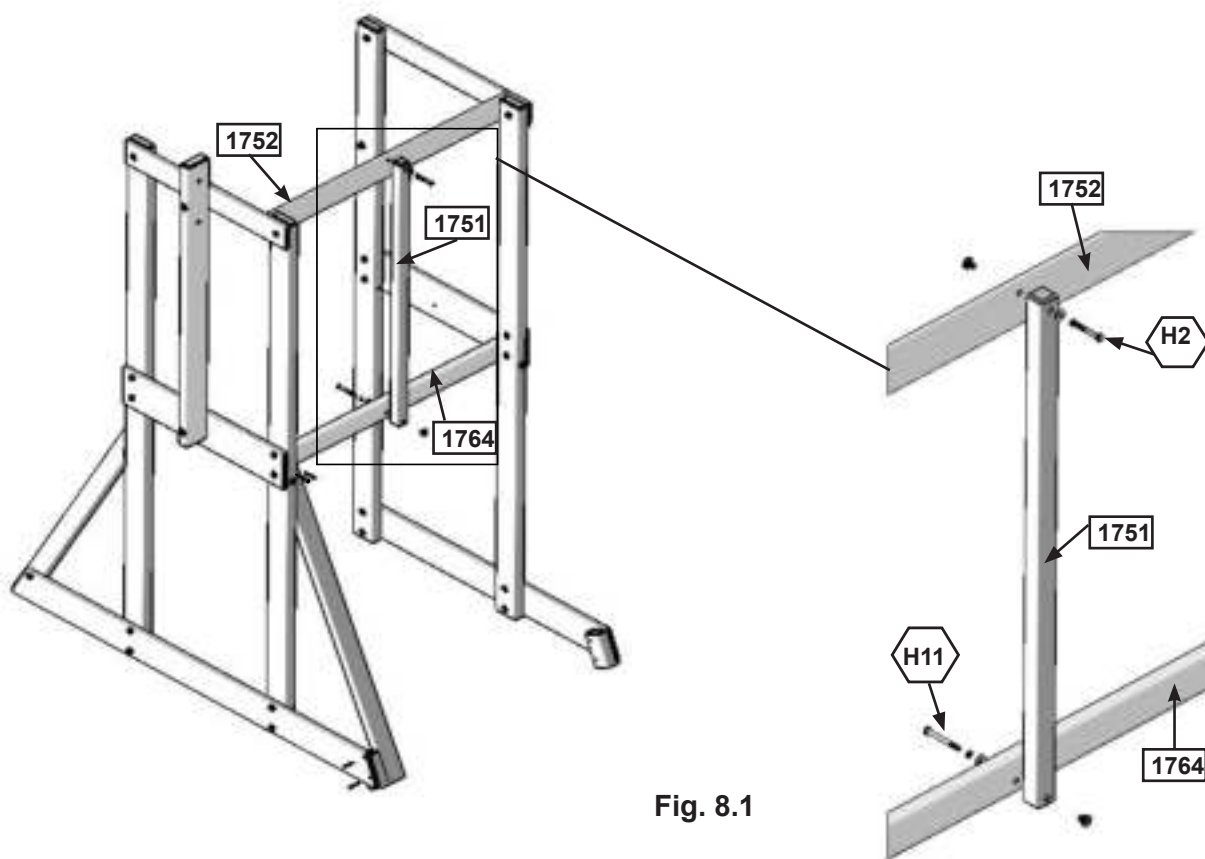

Fig. 8.1

Wood Parts

1 x [1751] Centre Divider 2 x 2 x 38"

Hardware

- 1 x [H2] 1/4 x 2" Hex Bolt
(1/4" lock washer, 1/4" flat washer, 1/4" t-nut)
- 1 x [H11] 1/4 x 2-3/4" Hex Bolt
(1/4" lock washer, 1/4" flat washer, 1/4" t-nut)



Step 9: Attach Gusset

A: Make sure assembly is square and then place 1 (0312) Gusset tight to the under side of (1764) Floor Front and to (1771) Post from the inside of the assembly. Make sure the gusset is flush to the outside of the post and attach with 2 (S4) #8 x 3" Wood Screws per side. (fig. 9.1, 9.2 & 9.3)

Fig. 9.1

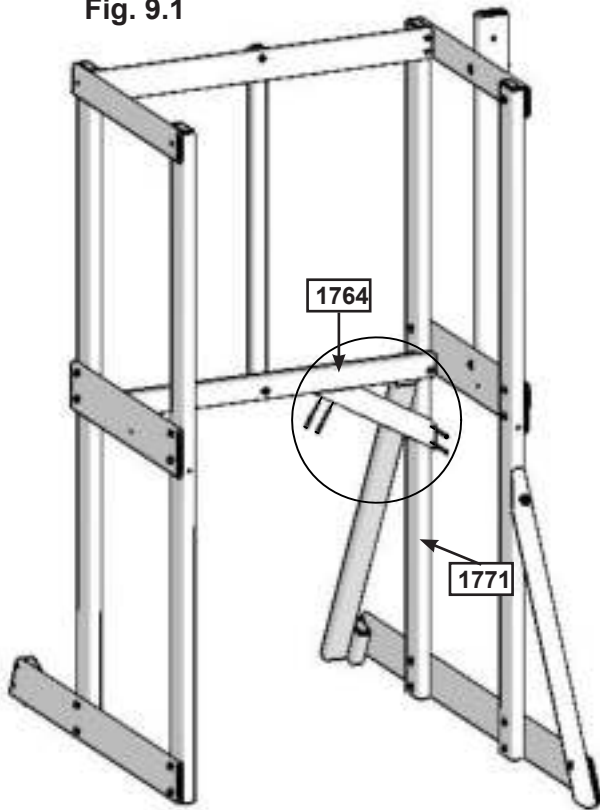
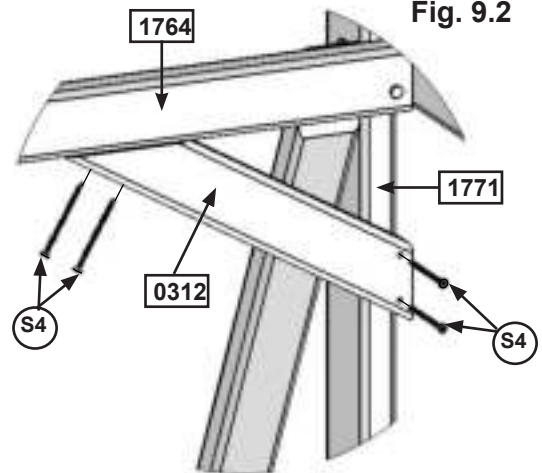
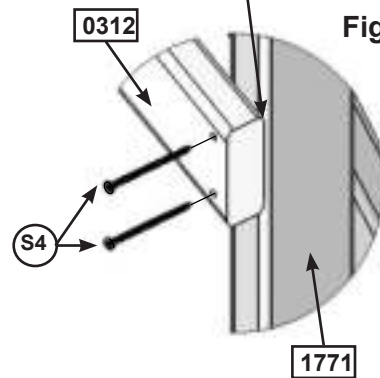

Fig. 9.2



Flush to
outside edge

Fig. 9.3



Wood Parts

1 x 0312 Gusset 2 x 3 x 16"

Hardware

4 x S4 #8 x 3" Wood Screw



Step 10: Attach Lower Front

A: Attach (1767) Lower Front flush to the top of (1766) Corner Block at (1769) Ground Side with 2 (S15) #8 x 1-3/4" Screws. (fig. 10.1 & 10.2)

B: Make sure (1767) Lower Front is level and then attach to (1765) Rock Rail with 2 (S15) #8 x 1-3/4" Screws. (fig. 10.1)

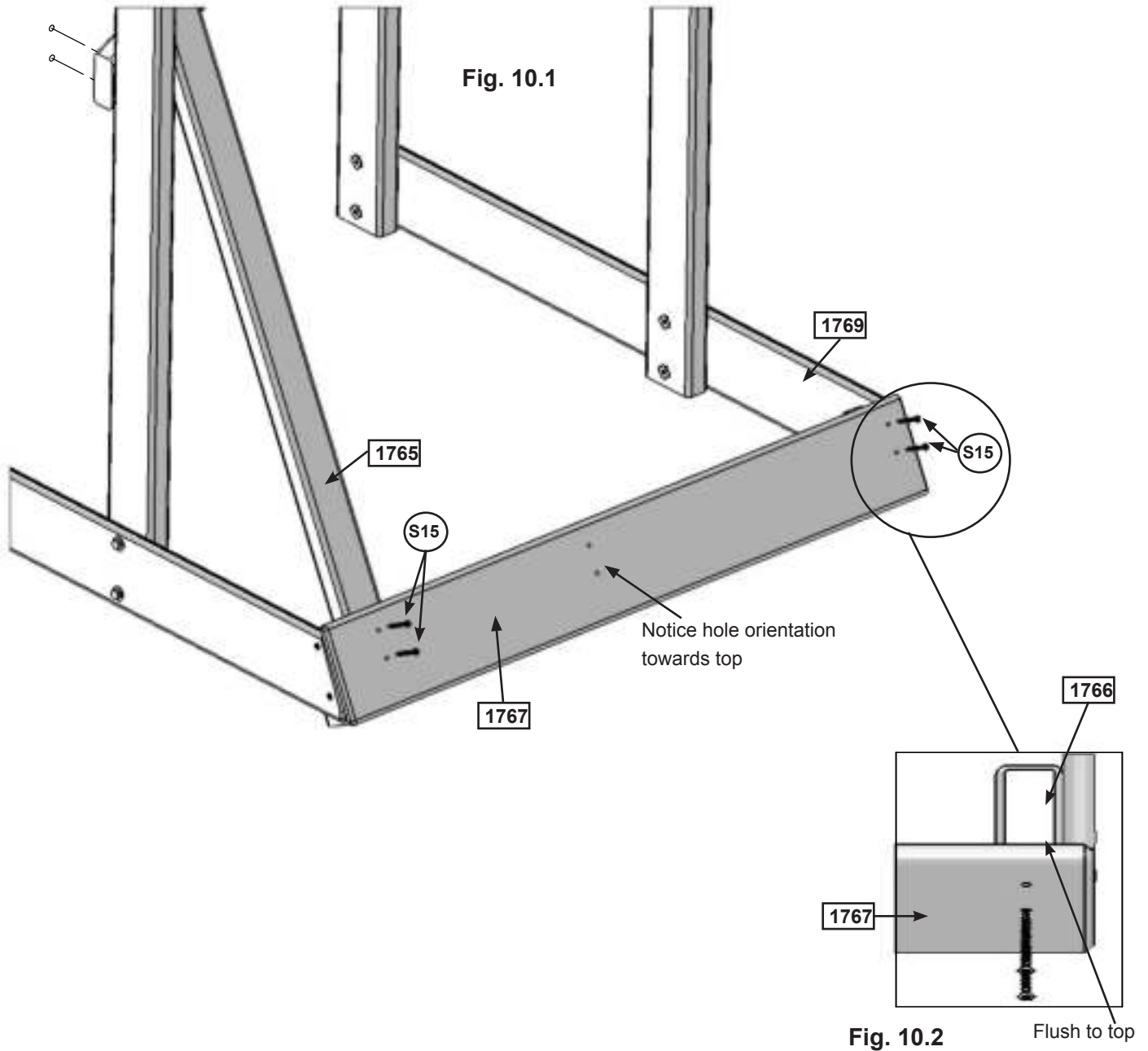

Wood Parts

1 x 1767 Lower Front 1 x 6 x 39-3/4"

Hardware

4 x S15 #8 x 1-3/4" Wood Screw

Step 11: Floor Back Assembly

A: Attach (1762) Floor Back to (1761) Side Joist with 2 (H3) 1/4 x 2-1/2" Bolts (with flat washer, lock washer and t-nut) and 2 (S7) 12 x 2" Pan Screws (with flat washers) as shown in fig. 11.1. (1761) Side Joist should be flush to the top of (1762) Floor Back. Bolts to be installed on (1761) Side Joist side and screws installed from (1762) Floor Back side.

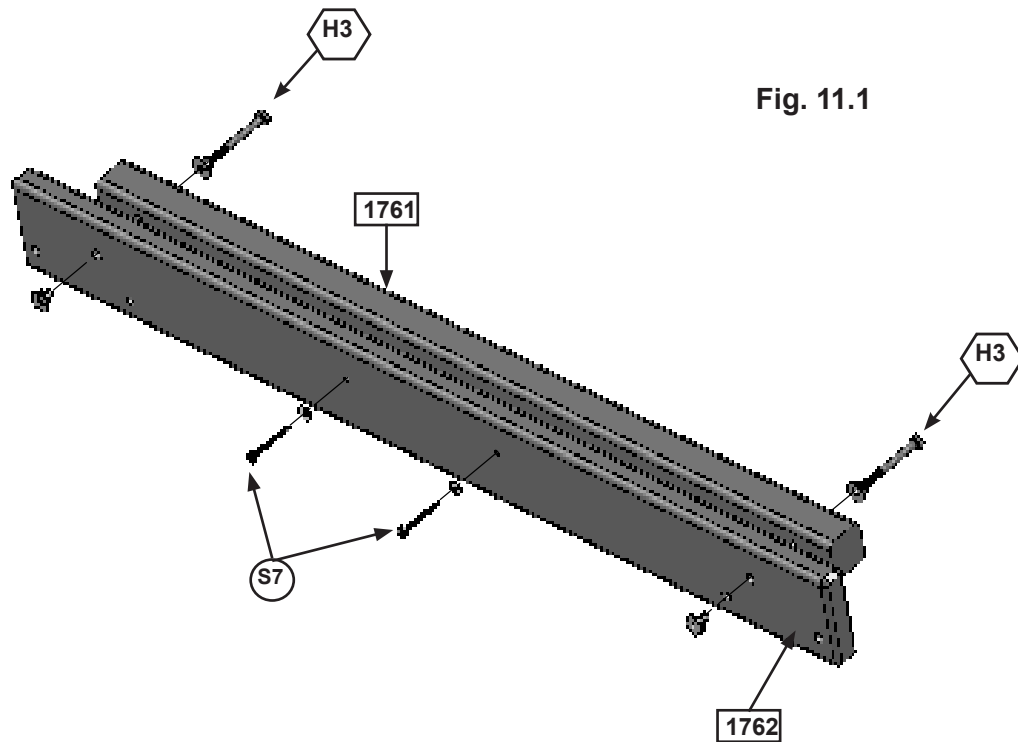

Wood Parts

- 1 x **1761** Side Joist 2 x 2 x 34-3/4"
- 1 x **1762** Floor Back 5/4 x 4 x 38-5/8"

Hardware

- 2 x **S7** #12 x 2 Pan Screw (with 3/16" flat washer)
- 2 x **H3** 1/4 x 2-1/2" Hex Bolt
(1/4" lock washer, 1/4" flat washer, 1/4" t-nut)

Step 12: Floor Back Assembly



Pre-drill all pilot holes using a 1/8" drill bit before installing the lag screws.

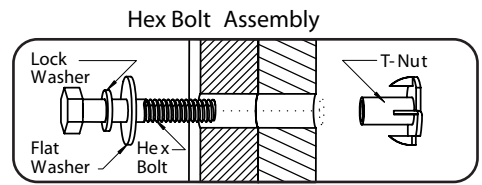
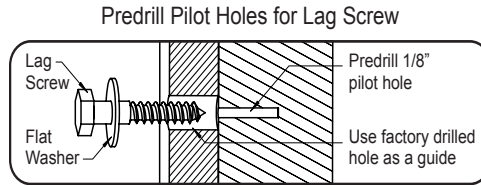

A: On the back side of the assembly attach (1768) Lower Back flush to the bottom and outside edge of (1771) Posts with 2 (LS3) 1/4 x 3" Lag Screws (with flat washer) in the top, pre-drilled holes and 2 (S7) 12 x 2" Pan Screws (with 3/16" flat washer) in the bottom holes as shown in fig. 12.1 & 12.3.

B: Attach Floor Back Assembly from Step 11 to both (1771) Posts with 2 (H5) 1/4 x 4-1/2" Hex Bolts (with lock washer, flat washer and t-nut) through (1762) Floor Back. Notice the hole orientation towards bottom of board. (fig. 12.1 & 12.2)

Fig. 12.1

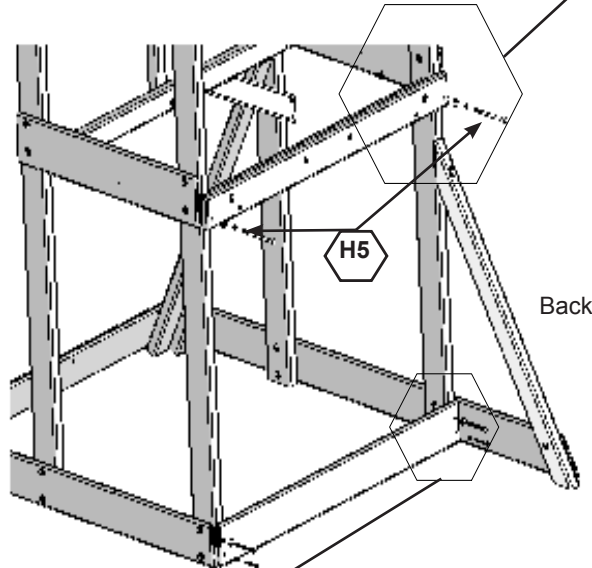

Fig. 12.2

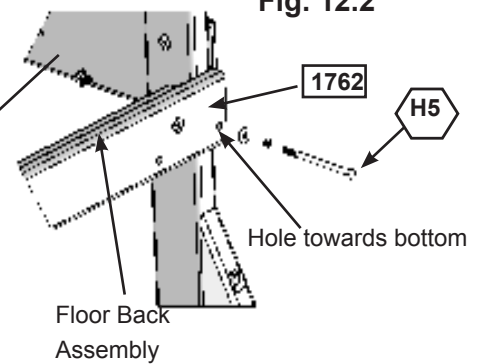
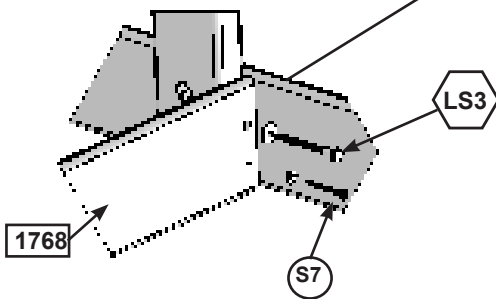

Fig. 12.3



Wood Parts

- 1 x Floor Back Assembly (from Step 11)
- 1 x 1768 Lower Back 1 x 5 x 38-1/2"

Hardware

- 2 x S7 #12 x 2" Pan Screw (with 3/16" flat washer)
- 2 x LS3 1/4 x 3" Lag Screw (1/4" flat washer)
- 2 x H5 1/4 x 4-1/2" Hex Bolt (1/4" lock washer, 1/4" flat washer, 1/4" t-nut)

Step 12: Floor Back Assembly cont.

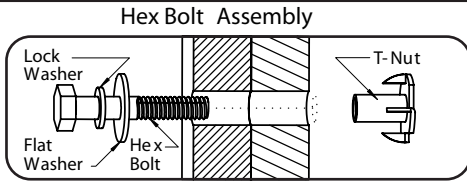
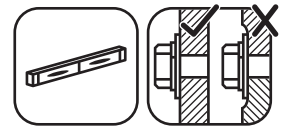

C: Attach 2 (0359) Front Dividers to (1762) Floor Back with 1 (H1) 1/4 x 1-1/2" Hex Bolt (with lock washer, flat washer and t-nut) per board. **Be sure to keep bolts loose.** (fig. 12.4 & 12.6)

D: Attach each (0359) Front Divider to (1758) Top Back using 1 (PB2) 1/4 x 1-1/4" Pan Bolt (with lock washer, flat washer and t-nut) per board. **Be sure to keep bolts loose.** (fig. 12.4 & 12.5)

E: Level and attach (1758) Top Back to both (1771) Posts using 4 (S7) #12 x 2" Pan Screws (with 3/16" flat washers). (fig. 12.7)

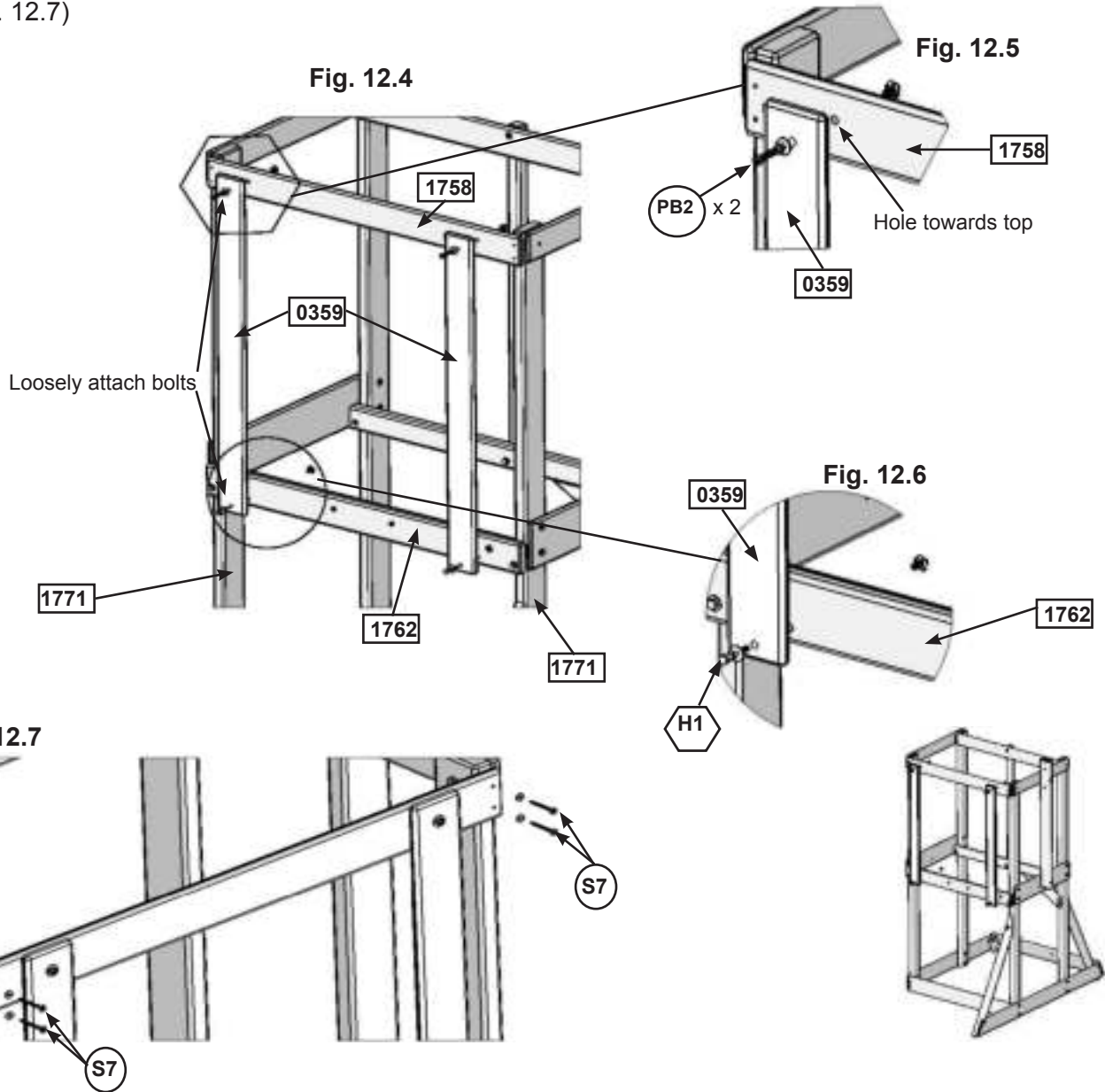

Wood Parts

- 1 x 1758 Top Back 1 x 4 x 38-1/2"
- 2 x 0359 Front Divider 1 x 4 x 38"

Hardware

- 4 x S7 #12 x 2" Pan Screw (with 3/16" flat washer)
- 2 x H1 1/4 x 1-1/2" Hex Bolt (1/4" lock washer, 1/4" flat washer, 1/4" t-nut)
- 2 x PB2 1/4 x 1-1/4" Pan Bolt (1/4" lock washer, 1/4" flat washer, 1/4" t-nut)

Step 13: Chalk Wall Assembly

A: Place the Chalk Wall Tarp in between each (0359) Front Divider and (1758) Top Back. Make sure tarp is taut and then attach to (1758) Top Back with 3 (S5) #8 x 1/2" Wood Screws (with #8 flat washer). Tighten the bolts in both (0359) Front Dividers. (fig. 13.1)

B: Recheck that tarp is taut and then attach Chalk Wall Tarp to both (0359) Front Dividers from the inside of the assembly with 2 (S5) #8 x 1/2" Pan Screws (with #8 flat washer) per board as shown in fig. 13.2.

C: 3" above (1762) Floor Back attach (1754) Lower Back Wall to each (0359) Front Divider with 4 (S1) #8 x 1-1/8" Wood Screws. (fig. 13.3)

D: Attach Chalk Wall Tarp to (1754) Lower Back Wall with 3 (S5) #8 x 1/2" Wood Screws (with #8 flat washer). (fig. 13.4)

Fig. 13.1

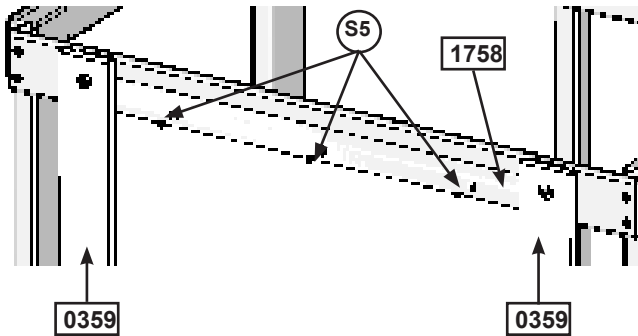

Fig. 13.2

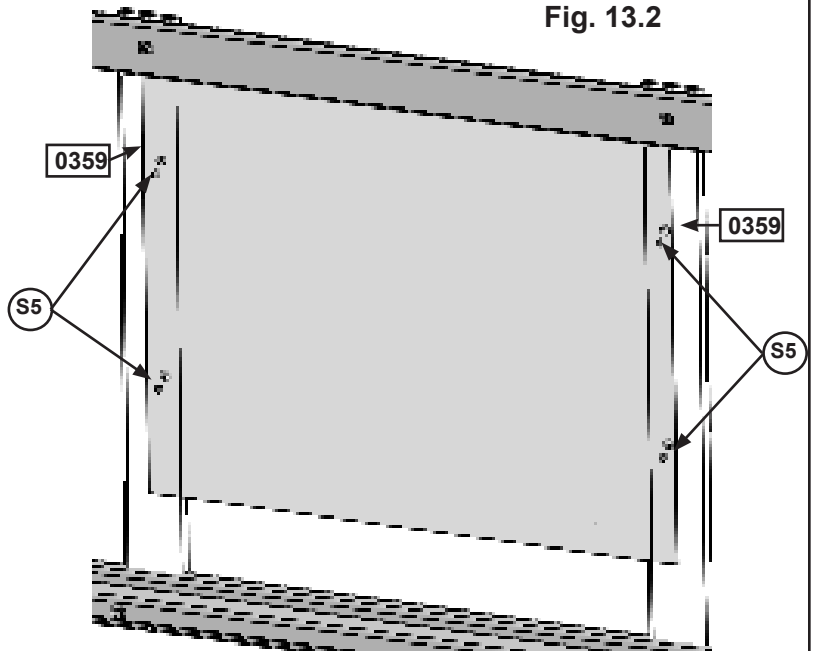

Fig. 13.4

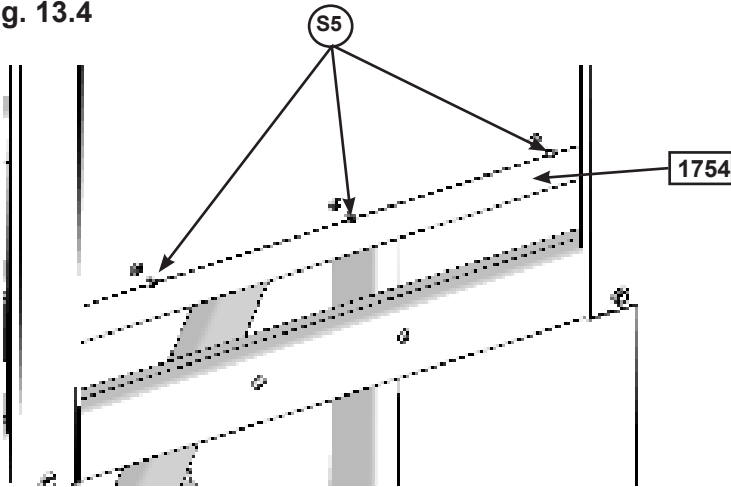
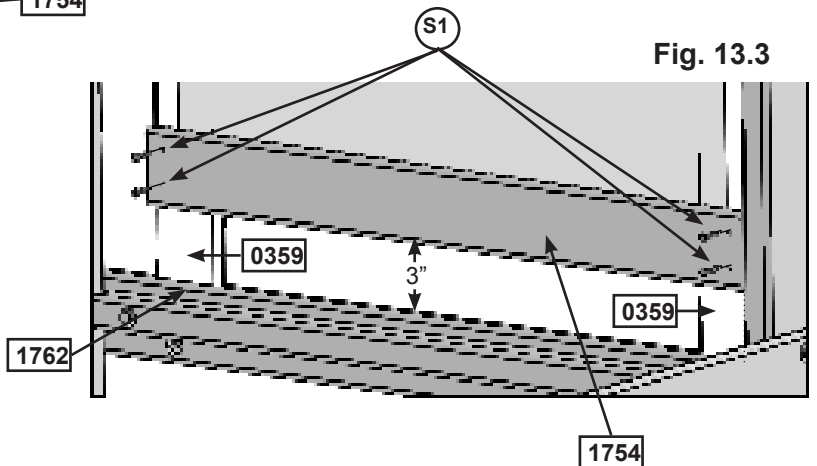

Fig. 13.3



Wood Parts

1 x [1754] Lower Back Wall 1 x 4 x 31-1/2"

Hardware

10 x (S5) #8 x 1/2 Pan Screw (with #8 flat washer)
4 x (S1) #8 x 1-1/8 Wood Screw

Other Parts

1 x Chalk Wall Tarp

Step 14: Floor Frame Assembly



A: From inside of the assembly, measure 3-1/8" down from the top of (1759) SW Floor (fig. 14.2) and (1760) Floor (fig. 14.3) and then attach (1763) Floor Joist to each board with 1 (S4) #8 x 3" Wood Screws per end. Make sure the (1763) Floor Joist is installed with the 1-3/8" side facing up. (fig. 14.1 & 14.2)

Fig. 14.2

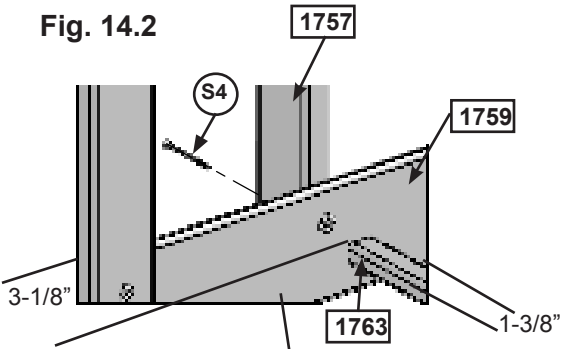

Fig. 14.1

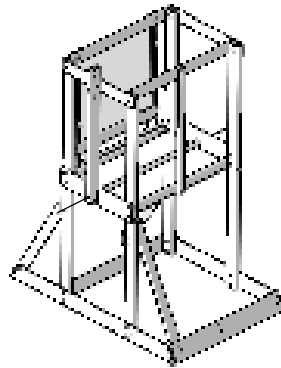
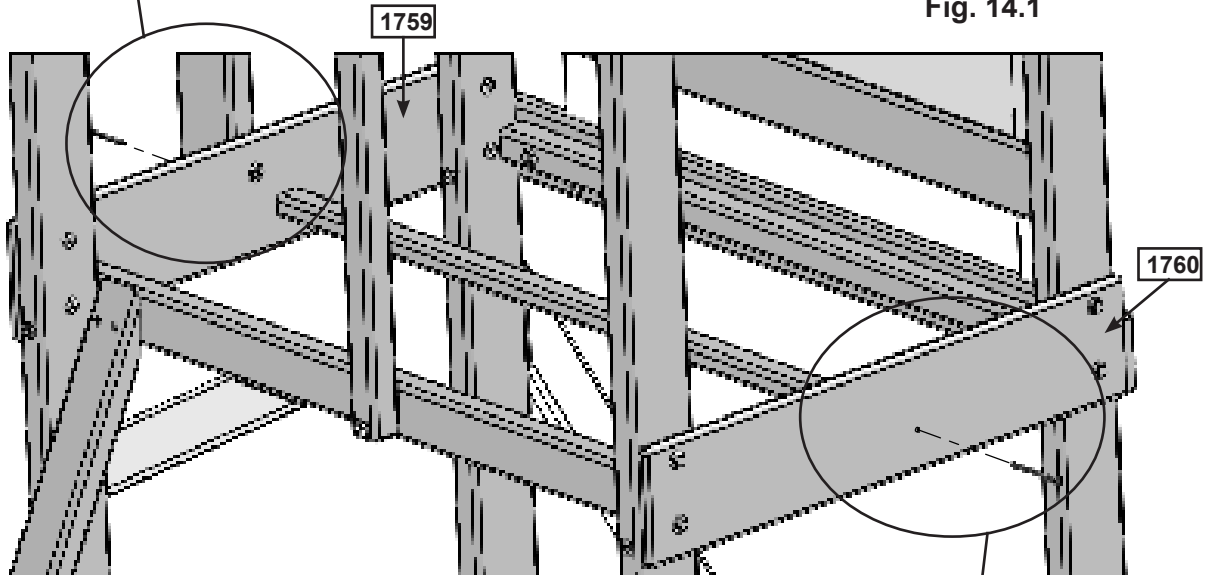
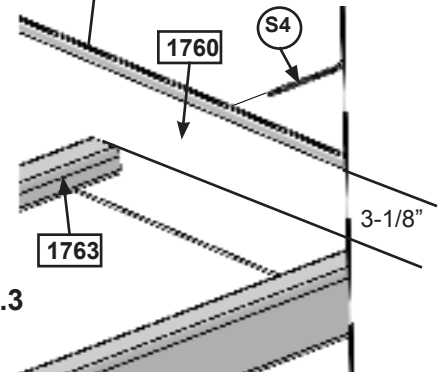

Fig. 14.3



Wood Parts

1 x **1763** Floor Joist 5/4 x 2 x 38-1/2"

Hardware

2 x **(S4)** #8 x 3" Wood Screw

Step 15: Attach Floor Boards

A: Install 1 (1774) CE Gap Board to each end of the assembly attaching to (1761) Side Joist, (1763) Floor Joist and (1764) Front Floor using 5 (S2) #8 x 1-1/2" Wood Screws per board. Make sure boards are tight to (1759) SW Floor, (1760) Floor, (1762) Floor Back and each (1771) Post. (fig. 15.1)

B: In between both (1774) CE Gap Boards place 5 (1776) Floor Boards making sure all boards are evenly spaced. Attach to (1761) Side Joist, (1763) Floor Joist and (1764) Front Floor using 5 (S2) #8 x 1-1/2" Wood Screws per board. All boards should be tight to (1762) Floor Back. (fig. 15.2)

C: Tight to (1751) Centre Divider and flush to top of (1776) Floor Board attach (1766) Corner Block to (1764) Floor Front with 2 (S3) #8 x 2-1/2" Wood Screws. (fig. 15.2 & 15.3)

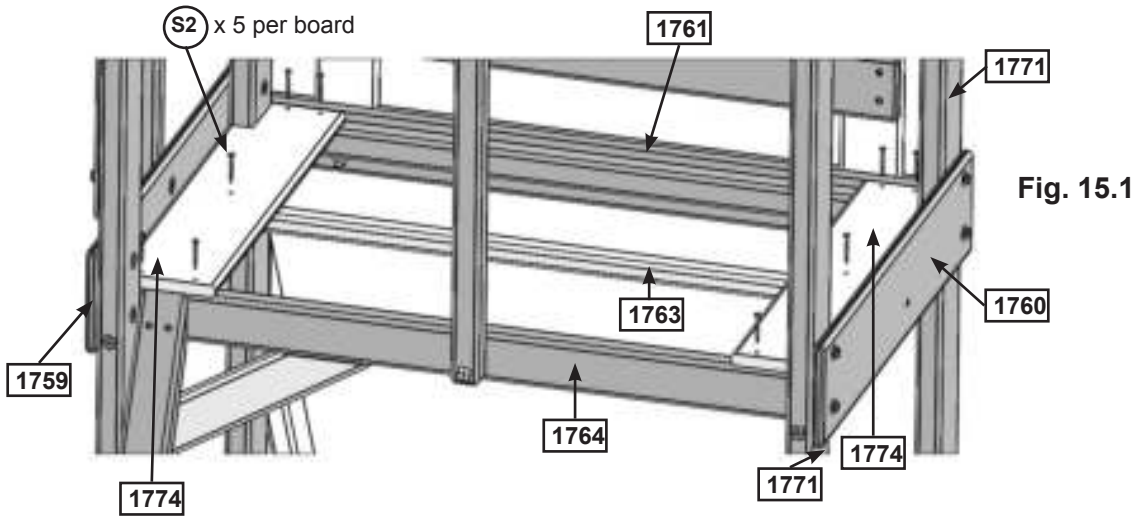

Fig. 15.3

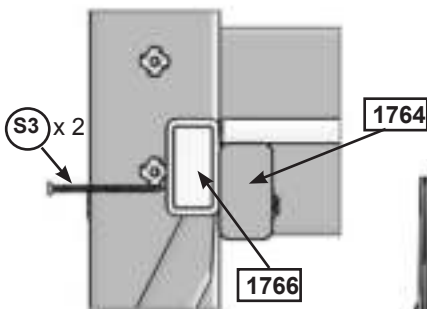
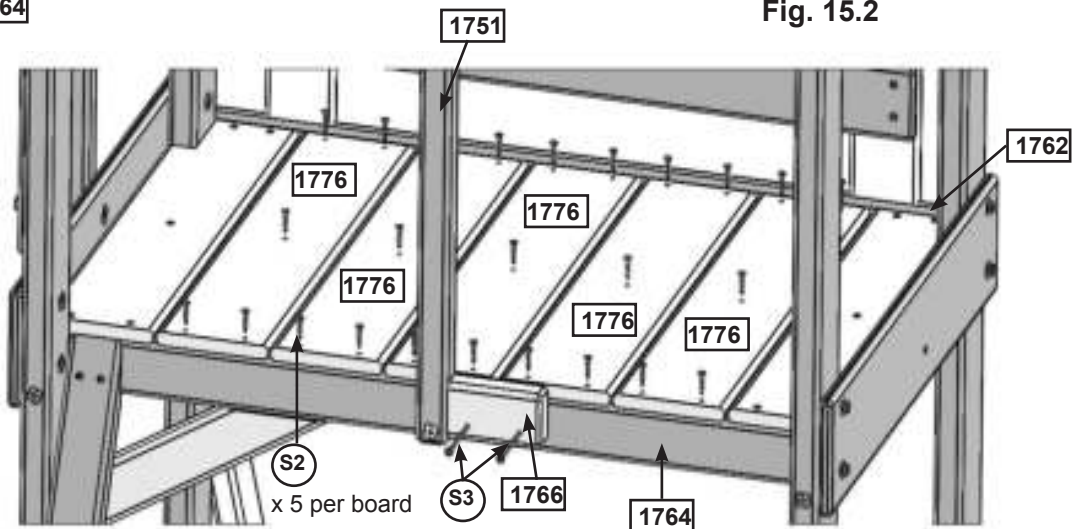

Fig. 15.2



Wood Parts

- 5 x 1776 Floor Board 1 x 6 x 23-1/2"
- 2 x 1774 CE Gap Board 1 x 6 x 23-1/2"
- 1 x 1766 Corner Block 2 x 3 x 4-1/2"

Hardware

- 35 x (S2) #8 x 1-1/2" Wood Screw
- 2 x (S3) #8 x 2-1/2" Wood Screw

Step 16: Attach Ground Stakes

MOVE FORT TO FINAL LOCATION. FINAL LOCATION MUST BE ON LEVEL GROUND

A: Drive 2 (0318) Ground Stakes 10-1/2" into the ground at the 2 (1771) Posts on (1770) SW Ground as shown in fig.16.1. Attach using 2 (S3) #8 x 2-1/2" Wood Screws per ground stake. (fig. 16.1)

⚠WARNING: To prevent tipping and avoid potential injury, stakes must be driven 10-1/2" into ground. Digging or driving stakes can be dangerous if you do not check first for underground wiring, cables or gas lines.

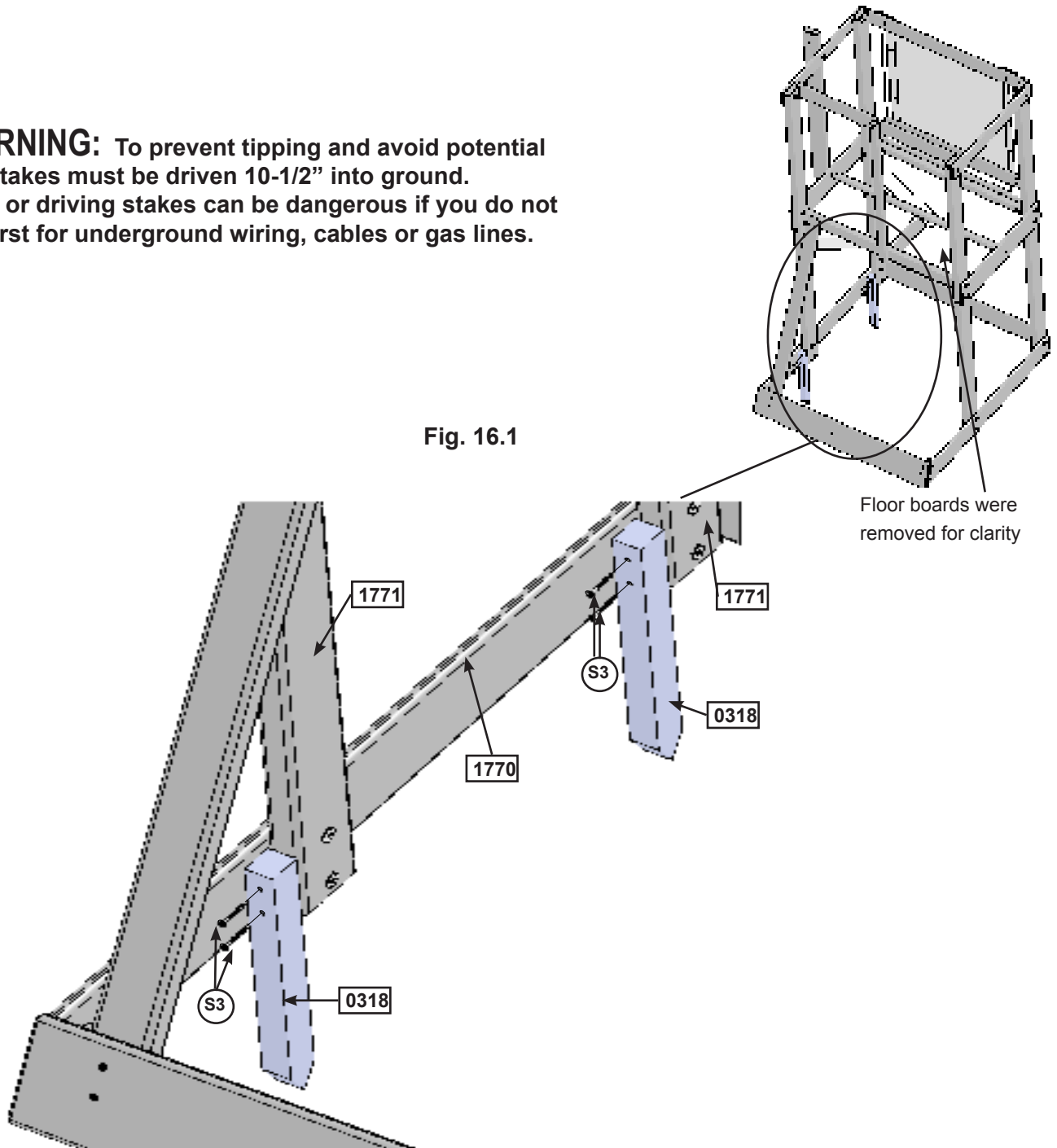

Wood Parts

2 x  Ground Stake 1 1/4 x 1 1/2 x 14"

Hardware

4 x  #8 x 2-1/2" Wood Screw



Step 17: Wall Assembly

A: On the Swing Side Wall attach 2 (0304) CE Floor Boards on either side of the (1757) Wall Mount with 4 (S1) #8 x 1 1/8" Wood Screws per board. Make sure the bottom of the boards are 1" up from the (1774) CE Gap Boards and there is approximately 3" between each (1771) Post and (0304) CE Floor Board, not exceeding 3-1/4". (fig. 17.1 & 17.2)

B: On the opposite wall attach 3 (0304) CE Floor Boards between the 2 (1771) Posts with 4 (S1) #8 x 1-1/8" Wood Screws per board. Make sure the bottom of the boards are 1" up from the (1774) CE Gap Board and there is approximately 2-1/2" between each board, not exceeding 2-3/4". (fig. 17.3 & 17.4)

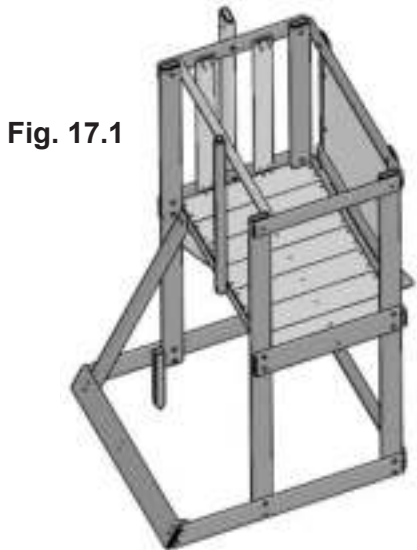

Fig. 17.1

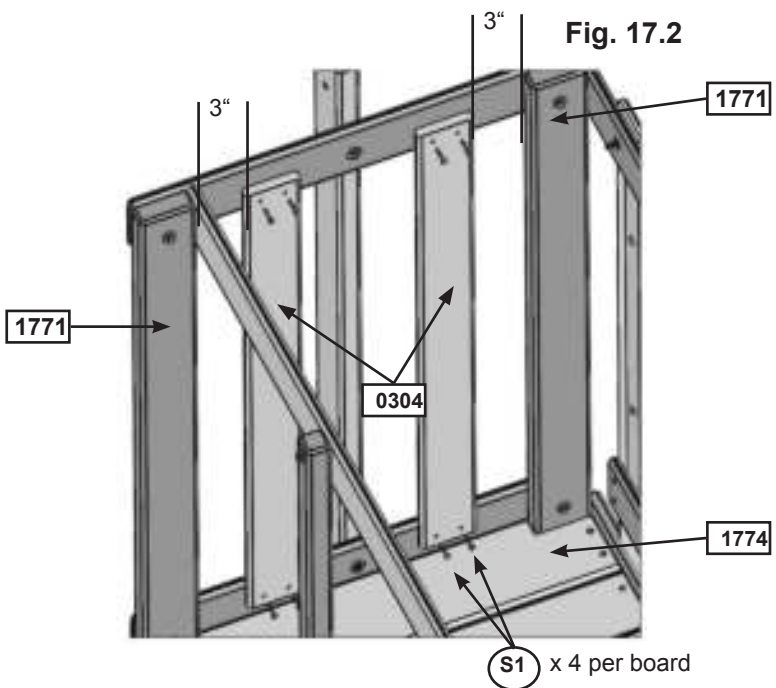

Fig. 17.2

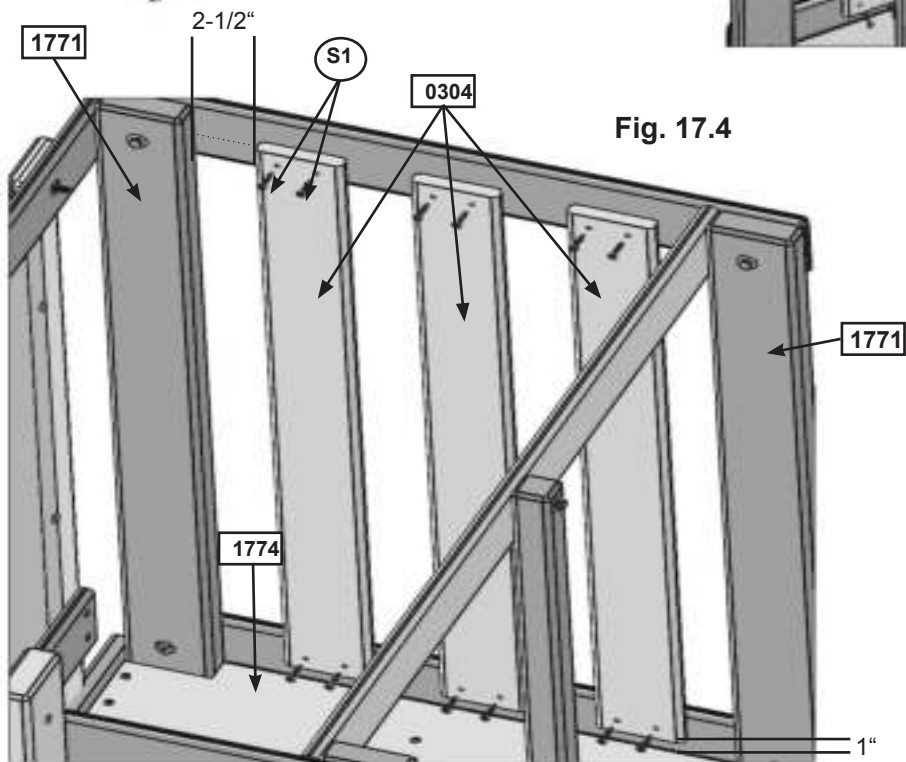

Fig. 17.4

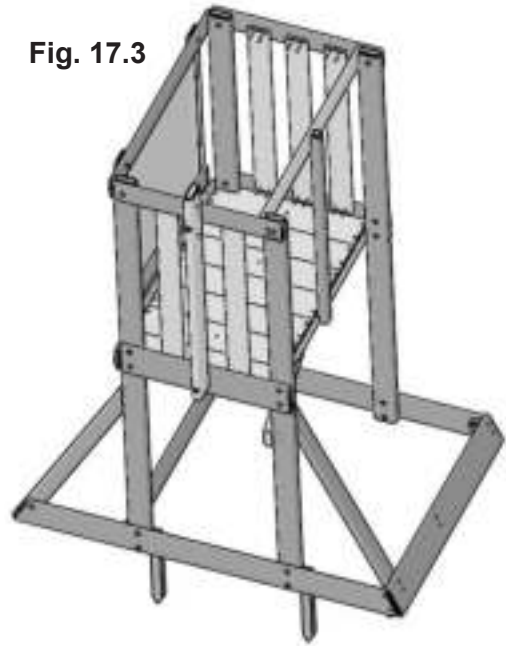

Fig. 17.3

Wood Parts

5 x 0304 CE Floor Board 1 x 4 x 32-1/2"

Hardware

20 x S1 #8 x 1-1/8" Wood Screw

Step 18: Canopy Roof Assembly



A: Feed both Canopy Tubes through each sleeve of the Canopy Roof until it reaches the mid point, then insert the Canopy Tubes through the holes in (1750) Tarp Support and bring it up to the centre line. (fig. 18.1)

B: Continue feeding Canopy Tubes through the rest of the Canopy Roof sleeves and then insert the ends of the tubes into tube holders. The flat side of the tube holders should face inwards. Make sure the notched out holes in the Canopy Roof are at the centre line. (fig. 18.1 & 18.2)

C: Place Canopy Roof on fort at (1748) SW Top and (1753) Top End as shown in fig. 18.3. The tube holders should be 5/8" from outside edge and 3/4" from top of (1748) SW Top and (1753) Top End. (fig. 18.4) Pre-drill holes for the screws and then attach tube holders to each board with the 4 (S10) #8 x 1" Pan Screws per tube holder. (fig. 18.3)

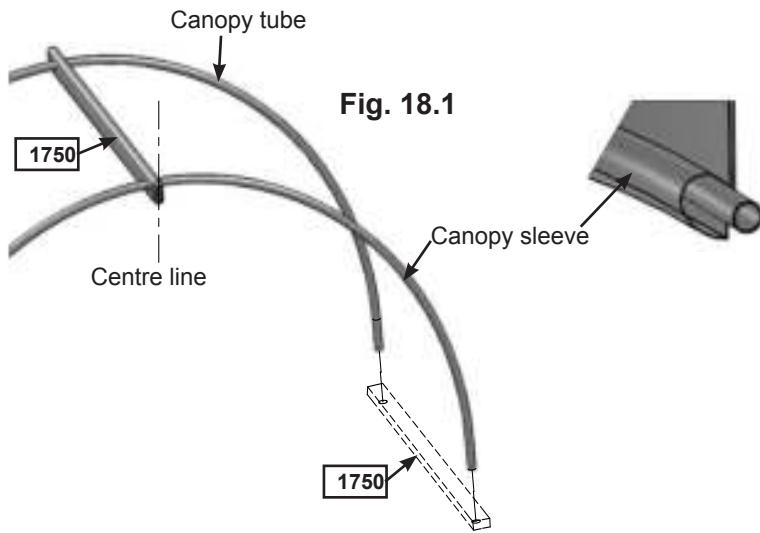

Fig. 18.1

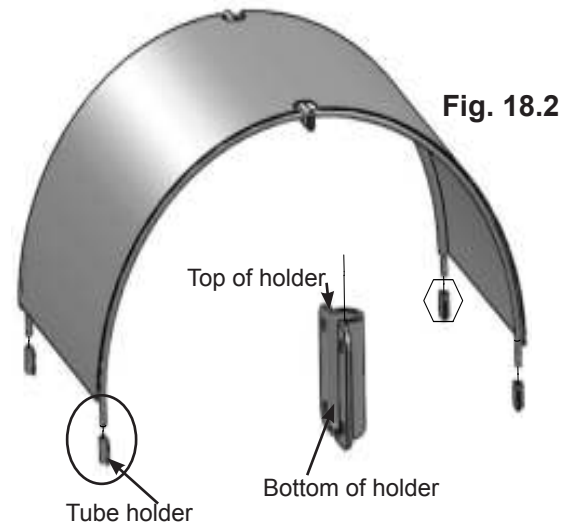

Fig. 18.2

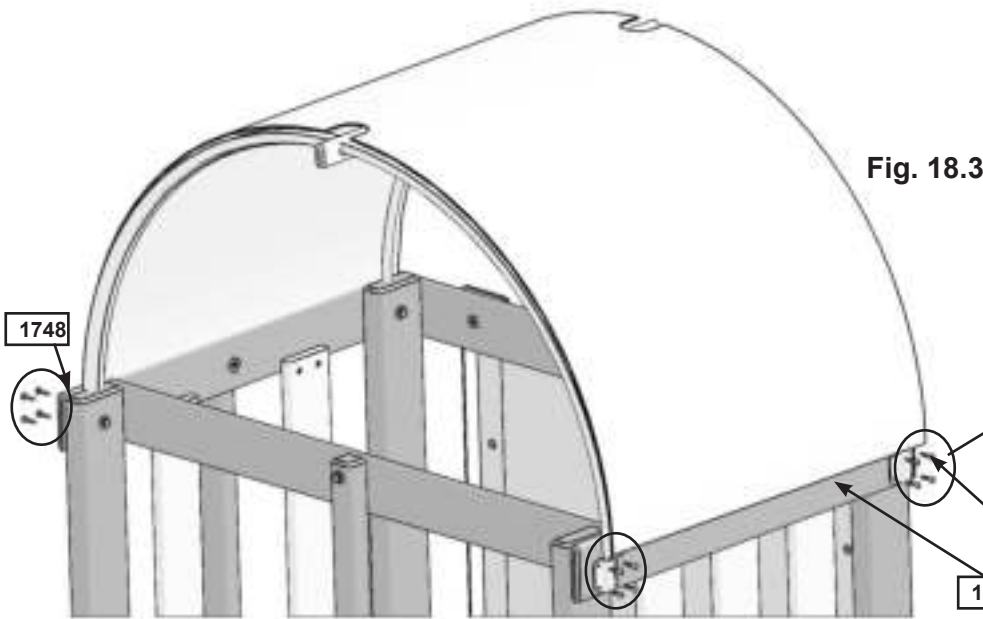

Fig. 18.3

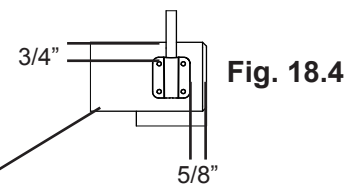

Fig. 18.4

Wood Parts

1 x 1750 Tarp Support 1 x 2 x 26-7/8"

Hardware

16 x S10 #8 x 1" Pan Screw

Other Parts

1 x Canopy
2 x Canopy Tube
4 x Canopy Tube Holder

Step 18: Canopy Roof Assembly cont.

D: Loosen the top bolt in (1757) Wall Mount, tuck Canopy Roof in between fort and (1757) Wall Mount and then secure Canopy Roof to (1748) SW Top and (1753) Top End with 4 (S5) #8 x 1/2" Pan Screws (with #8 flat washer) per board. Be sure to re-tighten bolt in (1757) Wall Mount. (fig. 18.5)

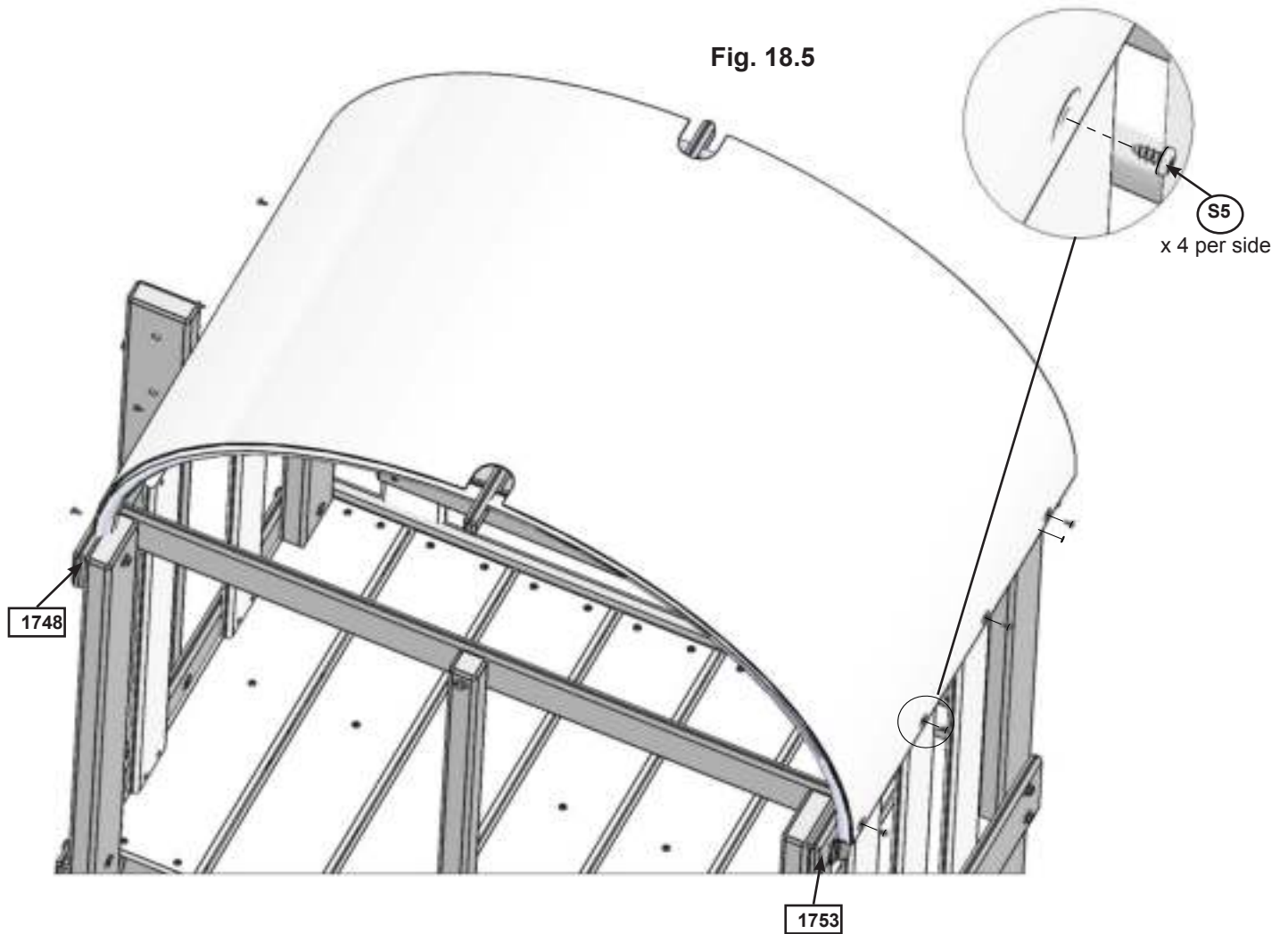

Hardware

8 x (S5) #8 x 1/2" Pan Screw (#8 flat washer)



Step 19: Attach Rock Rail

A: Attach 1 (1765) Rock Rail 17" from the already installed (1765) Rock Rail to (1764) Floor Front and (1767) Lower Front with 4 (S15) #8 x 1-3/4" Wood Screws. Top of (1765) Rock Rail angled edge should be flush to the top of (1764) Floor Front. (fig. 19.1 & 19.2)

B: Attach (1779) CE Access Board to the top of each (1765) Rock Rail as shown in fig. 19.5. Make sure (1779) CE Access Board is flush to the outside and top edges of each Rock Rail. Attach using 4 (S2) #8 x 1-1/2" Wood Screws. (fig. 19.5)

C: 2" down from the bottom of (1779) CE Access Board attach 1 (1778) CE Rock Board A, followed by 2 (1777) CE Rock Board B and 1 more (1778) CE Rock Board A, making sure the sides are flush to the outside edges of each (1765) Rock Rail. Stagger Rock Boards so the rock holes do not form a straight line. Attach using 4 (S2) #8 x 1-1/2" Wood Screws. Make sure the gap between boards are spaced 2" and do not exceed 2-1/4". (fig. 19.5)

D: Place 1 rock on each (1777) CE Rock Board A and (1778) CE Rock Board B (fig. 19.3) and attach using included hardware. The screw must be in the hole directly under the Pan Bolt, it will stop the rock from spinning. (fig. 19.4)

Fig. 19.1

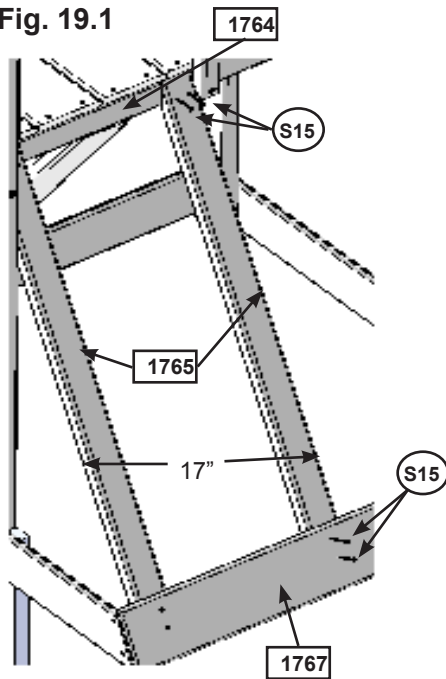

Fig. 19.2

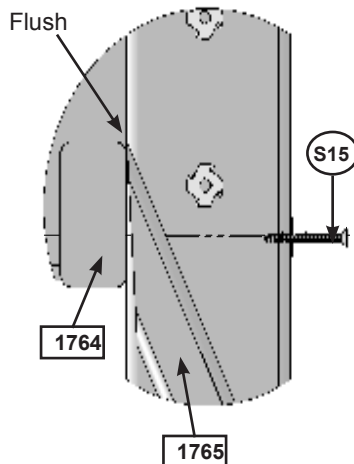

Fig. 19.3

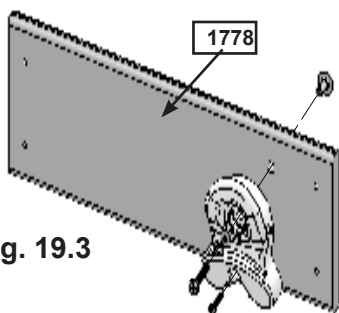

Fig. 19.4

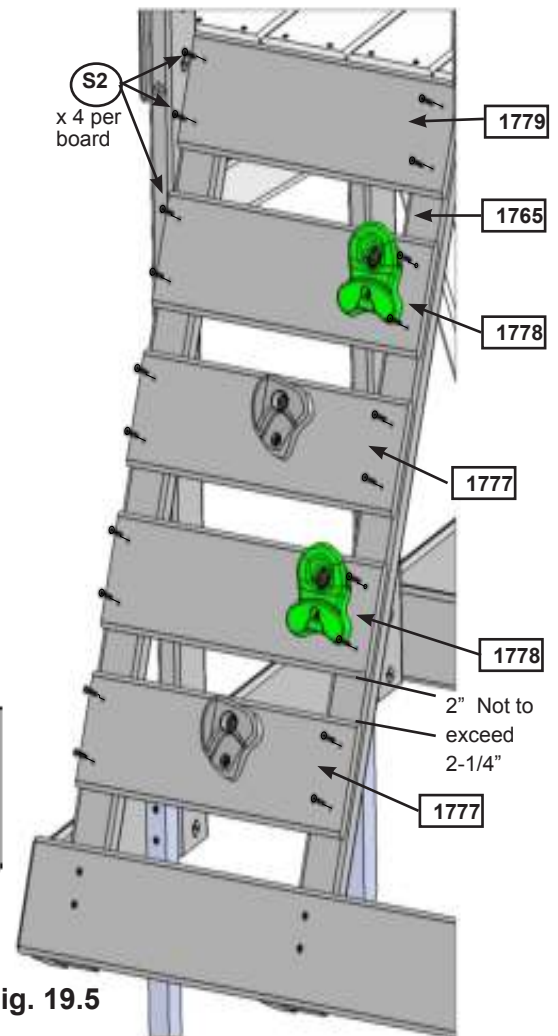
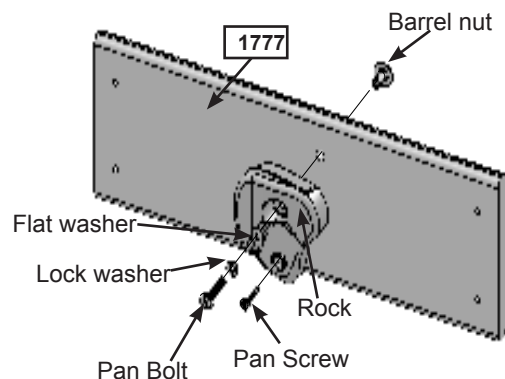

Fig. 19.5

Wood Parts

- 2 x 1778 CE Rock Board A 1 x 6 x 17"
- 2 x 1777 CE Rock Board B 1 x 6 x 17"
- 1 x 1779 CE Access Board 1 x 6 x 17"
- 1 x 1765 Rock Rail 2 x 3 x 42-3/4"

Hardware

- 20 x S2 #8 x 1-1/2" Wood Screw
- 4 x S15 #8 x 1-3/4" Wood Screw

Other Parts

- 1 x Rock with hardware (pkg of 4)



Step 20: Attach Slide

A: Beside Rock Wall, centre slide in opening between (1751) Centre Divider and (1771) Post.

B: Pre-drill 1/8" pilot holes and attach slide to fort through the floor boards and into (1764) Floor Front using 2 (S7) #12 x 2" Pan Screws. (fig. 20.1 & 20.2)

Fig. 20.1

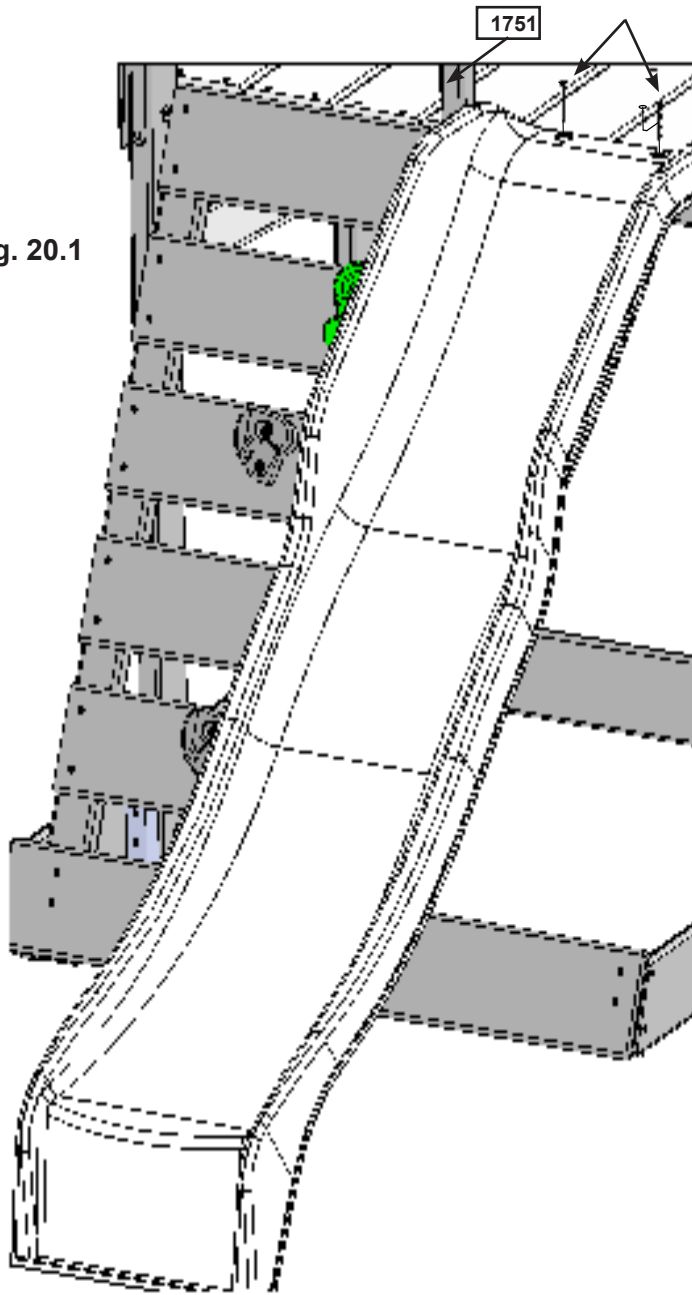
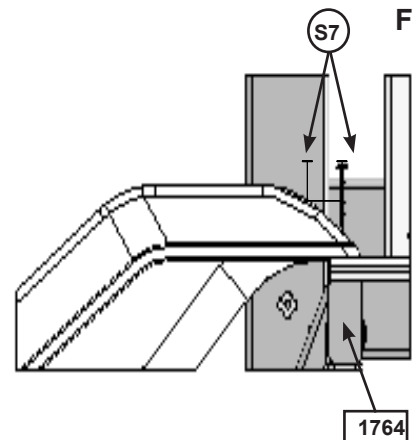

Fig. 20.2



Hardware

2 x (S7) #12 x 2" Pan Screw

Other Parts

1 x Slide

Step 21: Attach Swing To Fort

Hex Bolt Assembly

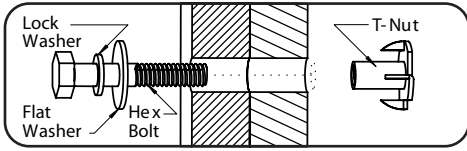

A: Attach Swing Assembly from Step 3 to (1757) Wall Mount with 1 (G5) 5/16 x 4-1/2" Hex Bolt (with lock washer, flat washer and t-nut) and 1 (G8) 5/16 x 2" Hex Bolt (with 2 flat washers and 1 lock nut) as shown in fig. 21.1 & 21.2.

Fig. 21.1

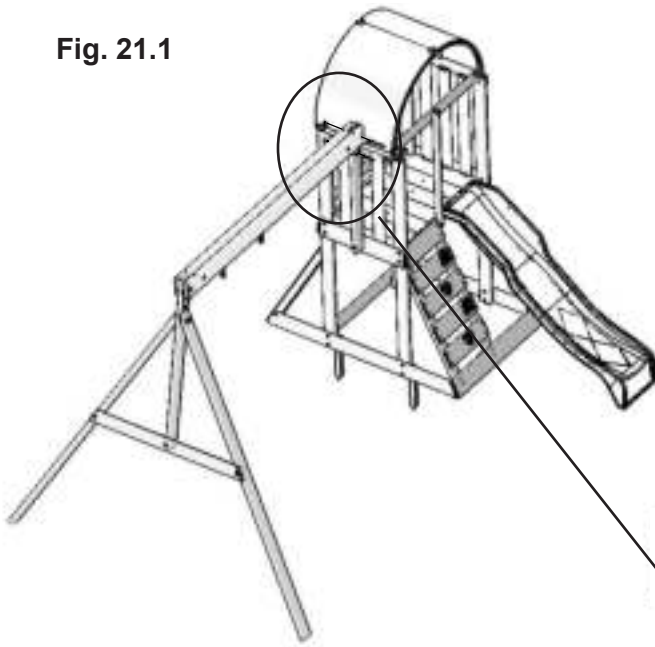
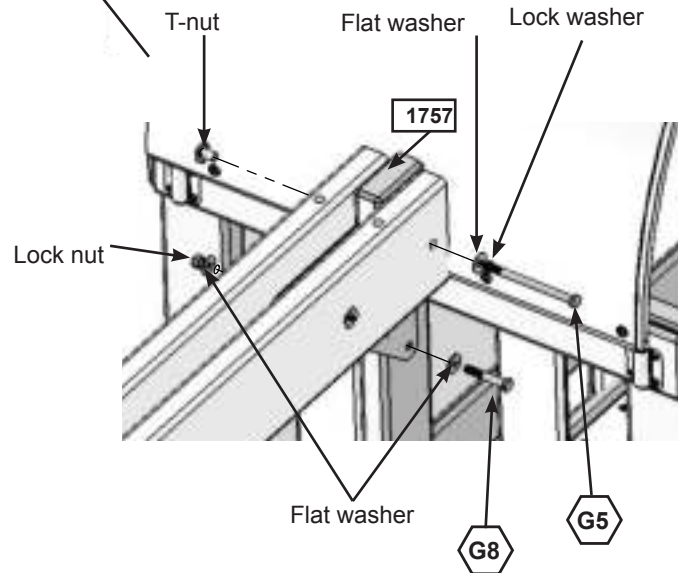



Fig. 21.2



Hardware

- 1 x  5/16 x 4-1/2" Hex Bolt
(5/16" lock washer, 5/16" flat washer, 5/16" t-nut)
- 1 x  5/16 x 2" Hex Bolt
(5/16" flat washer x2, 5/16" lock nut)

Step 22: Attach Ground Stakes to Swing End

A: Drive 1 (0318) Ground Stake 10-1/2" into the ground at each (1749) SW Post on the inside of the assembly and attach with 2 (S3) #8 x 2-1/2" Wood Screws per ground stake. (fig. 22.1 & 22.2)

⚠WARNING: To prevent tipping and avoid potential injury, stakes must be driven 10-1/2" into ground. Digging or driving stakes can be dangerous if you do not check first for underground wiring, cables or gas lines.

Fig. 22.1

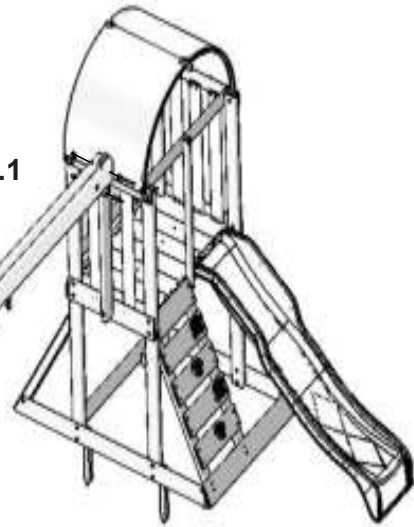
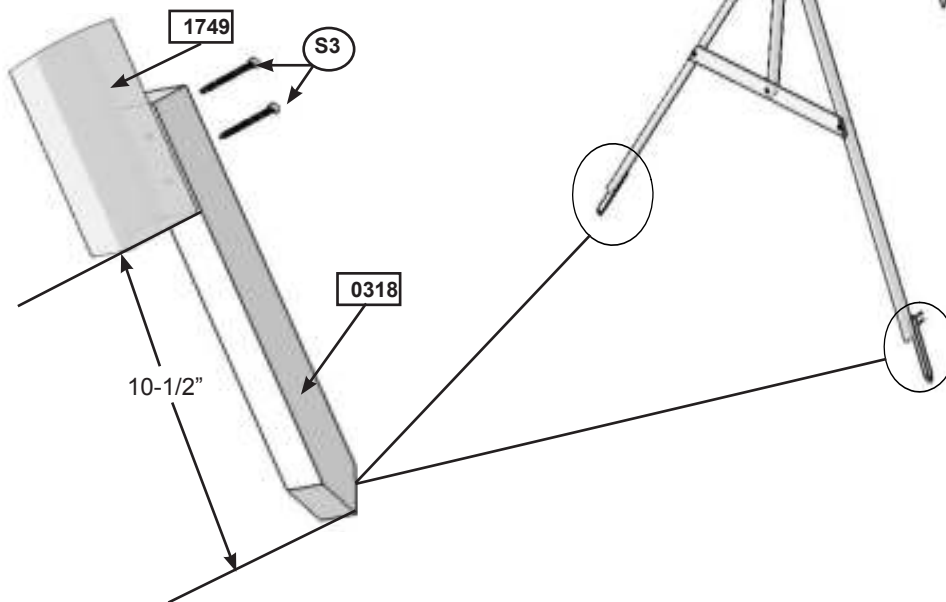

Fig. 22.2



Wood Parts

2 x 0318 Ground Stake 1 1/4 x 1 1/2 x 14"

Hardware

4 x S3 #8 x 2-1/2" Wood Screw

Step 23: Attach Swings

A: Attach 2 Belt Swings to the Bolt-Thru Swing Hangers. (fig. 23.1)

Fig. 23.1

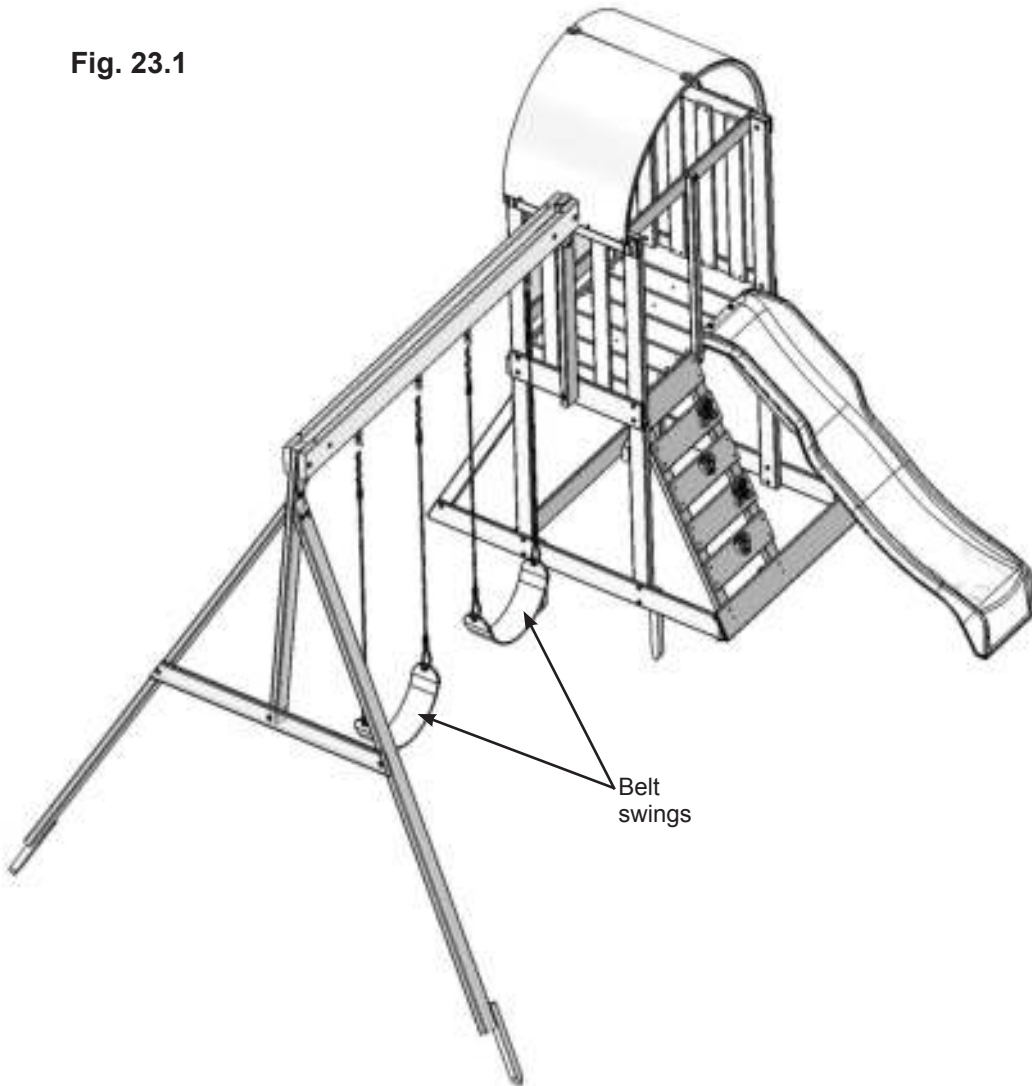

Other Parts

2 x Belt Swing

Final Step: Attach I.D. Plaque

ATTACH THIS WARNING & I.D. PLAQUE TO A PROMINENT LOCATION ON YOUR PLAY EQUIPMENT! (Fort or Swing Post)

This provides warnings concerning safety and important contact information. A Tracking Number is provided to allow you to get critical information or order replacement parts for this specific model.

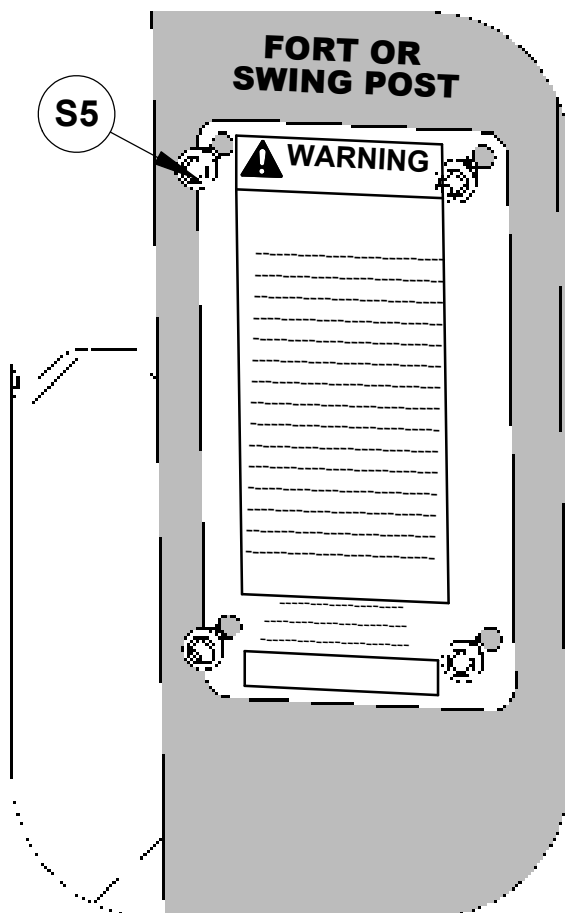

Attach with (S5) #8 x 1/2" Pan Screws to a location on your set that is easily seen and read by a supervising adult.

