

MAX / CONNECT

buro
schreibtisch
desk

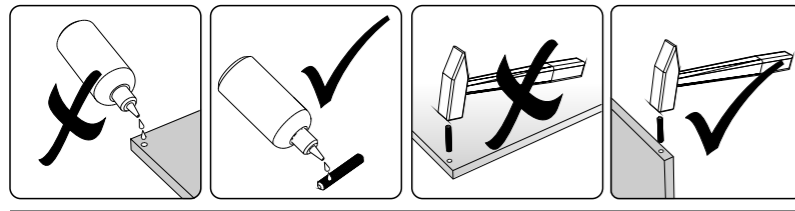
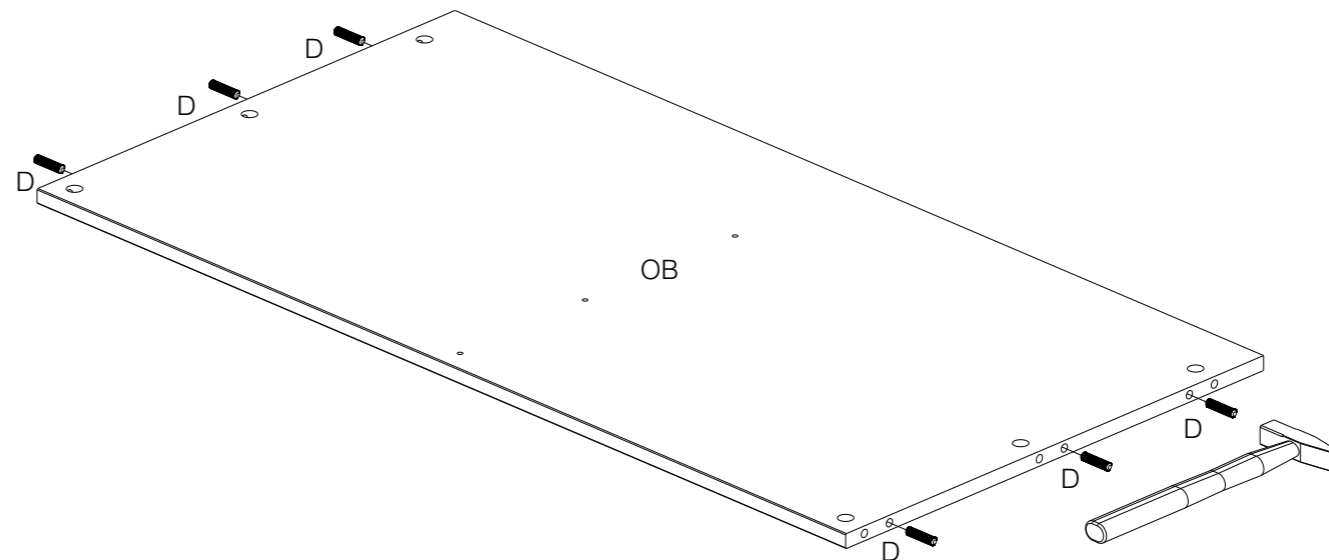
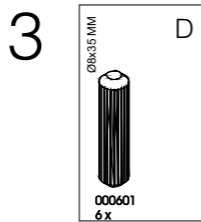
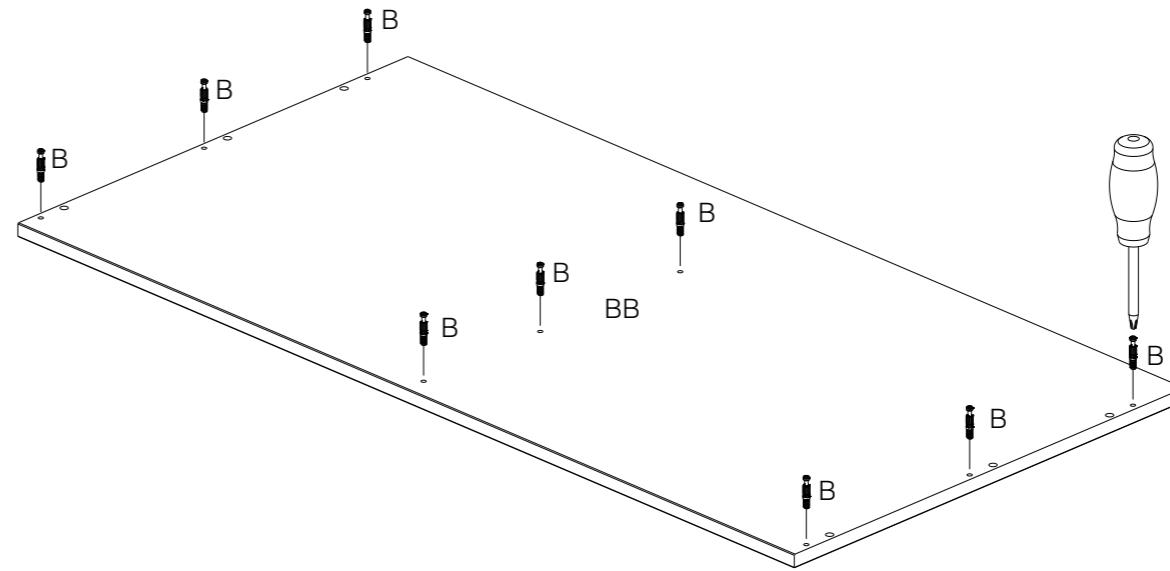
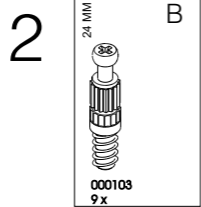
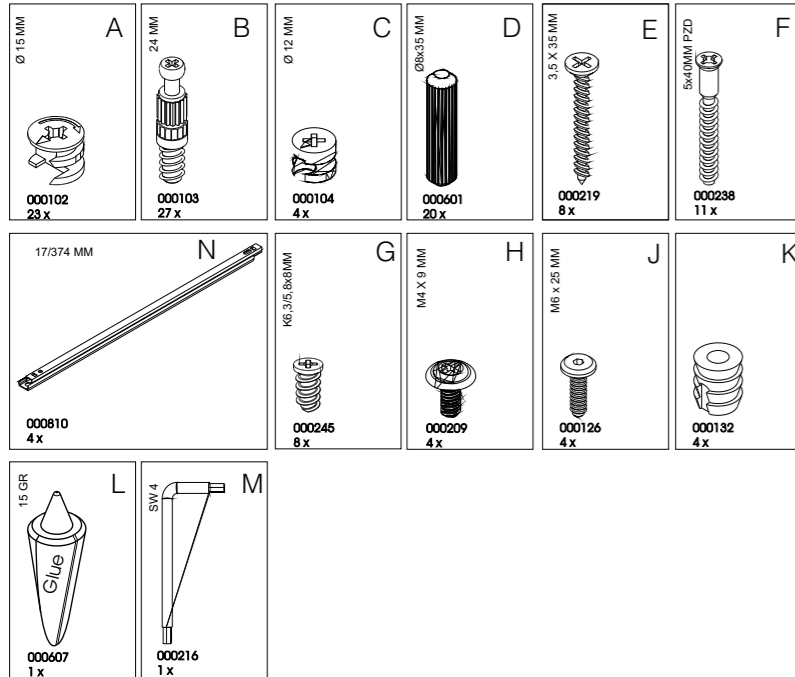
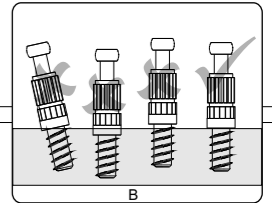
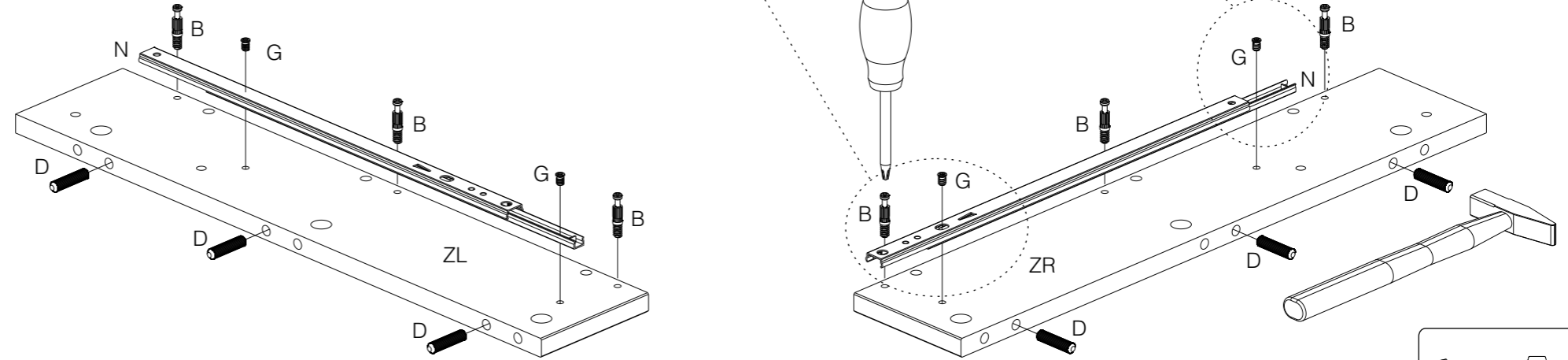
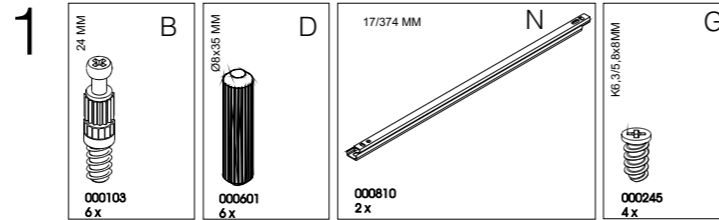

Produced by De Eekhoorn Woodworkings BV

4

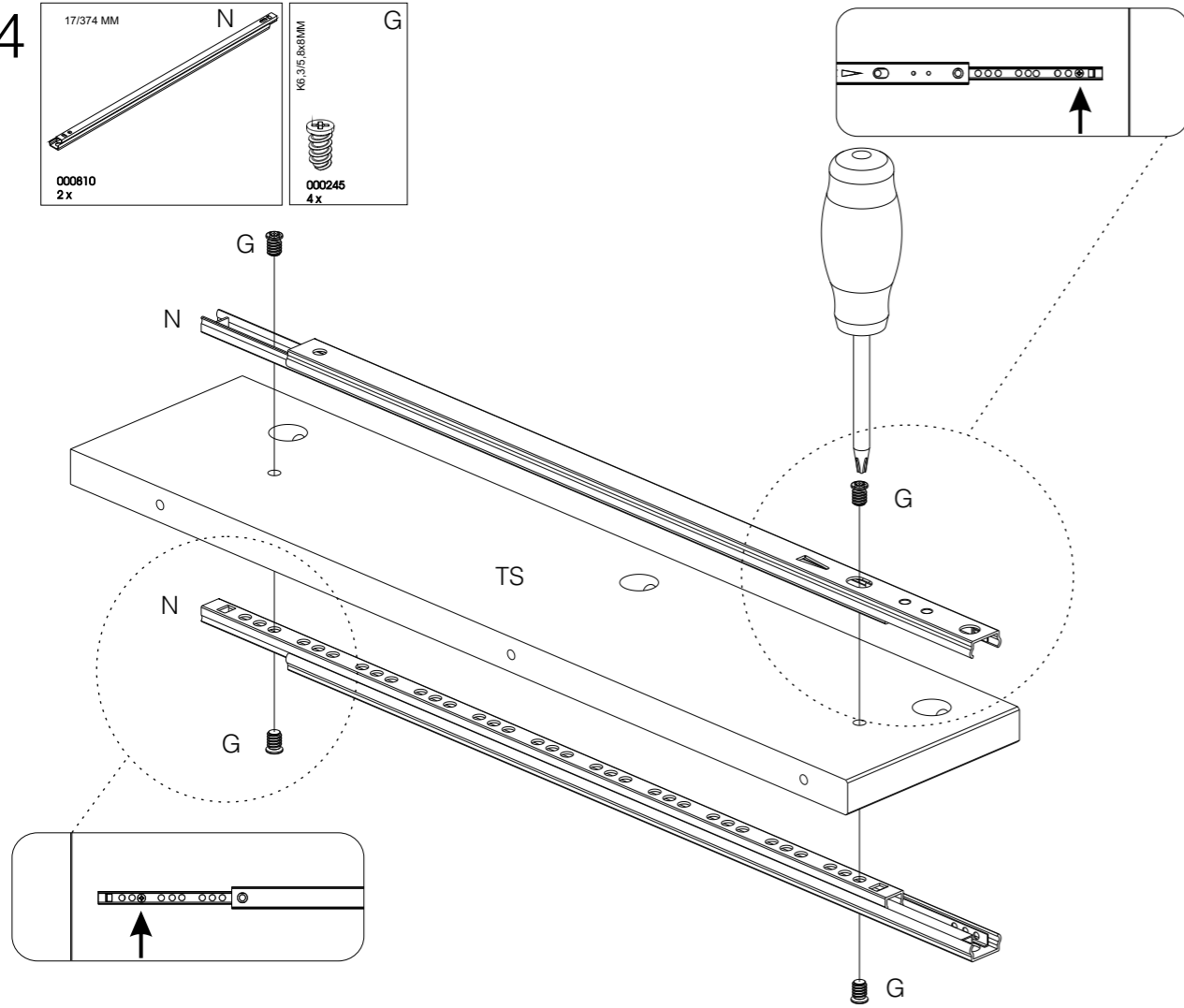
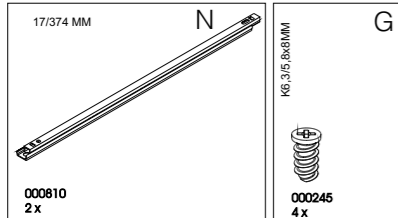

5

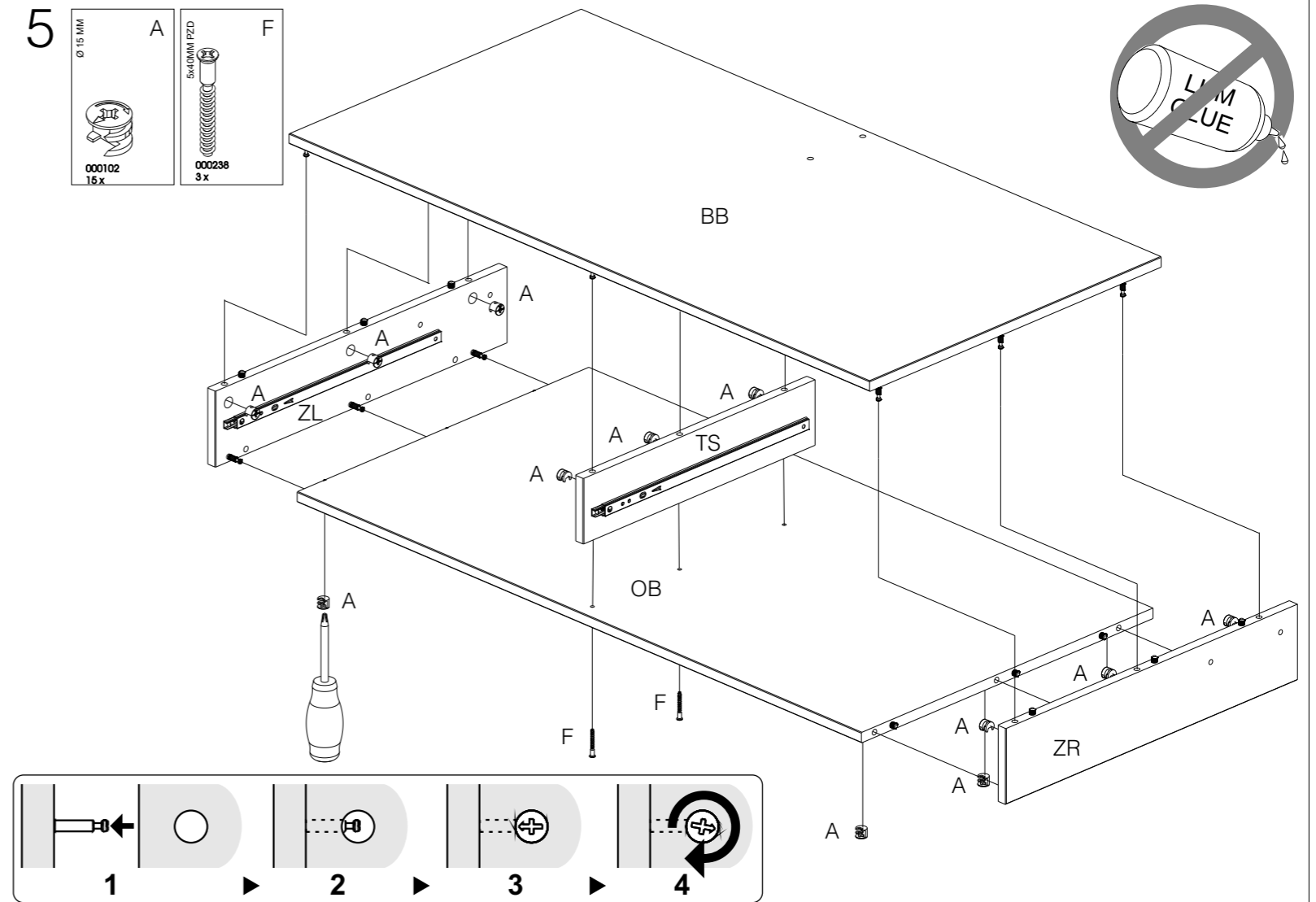
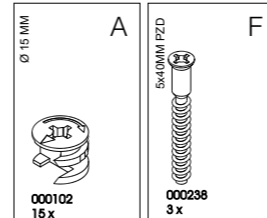

6

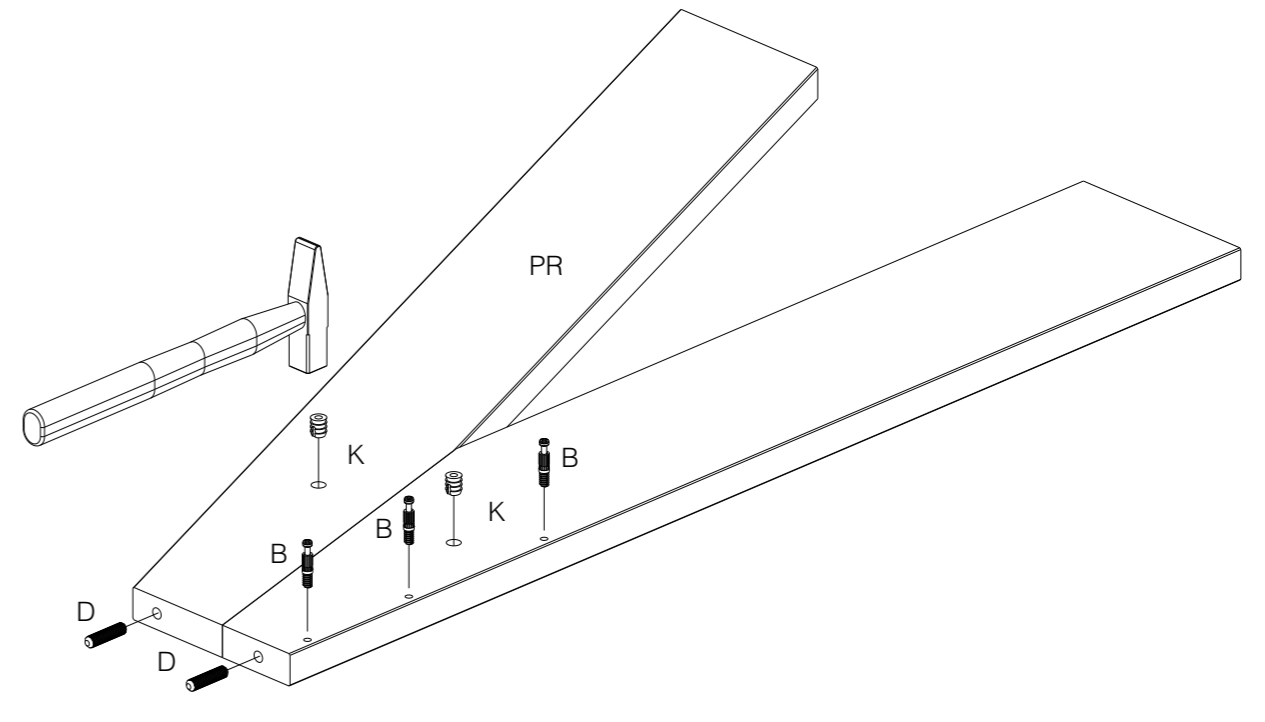
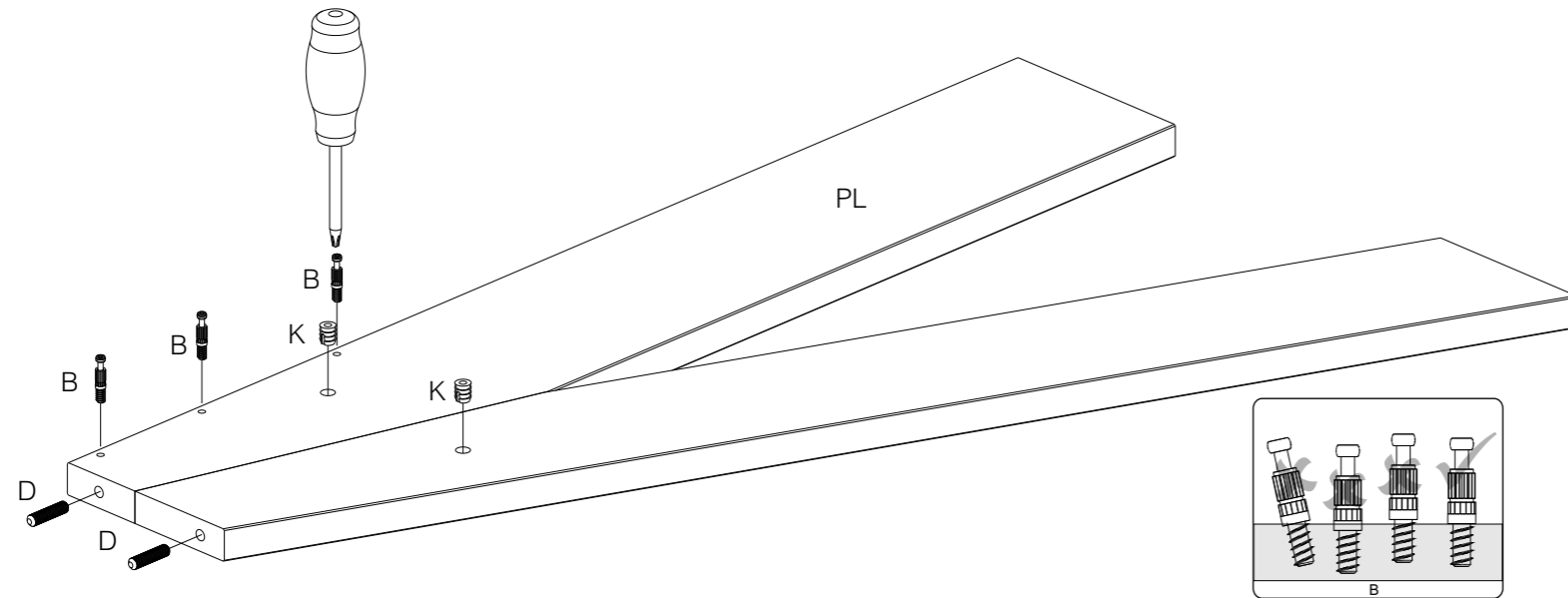
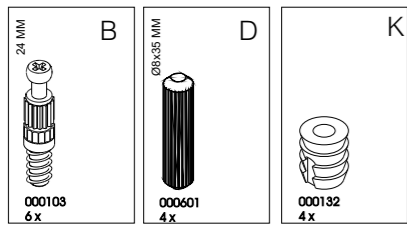

7

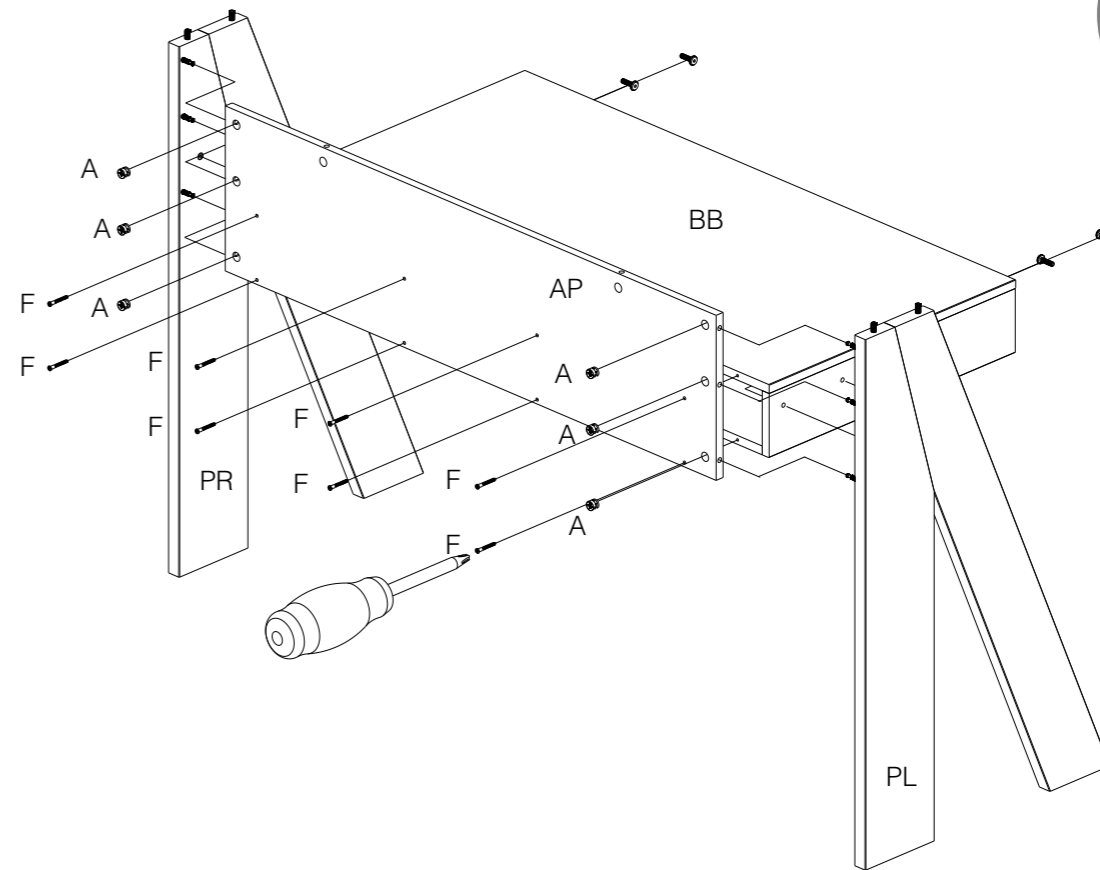
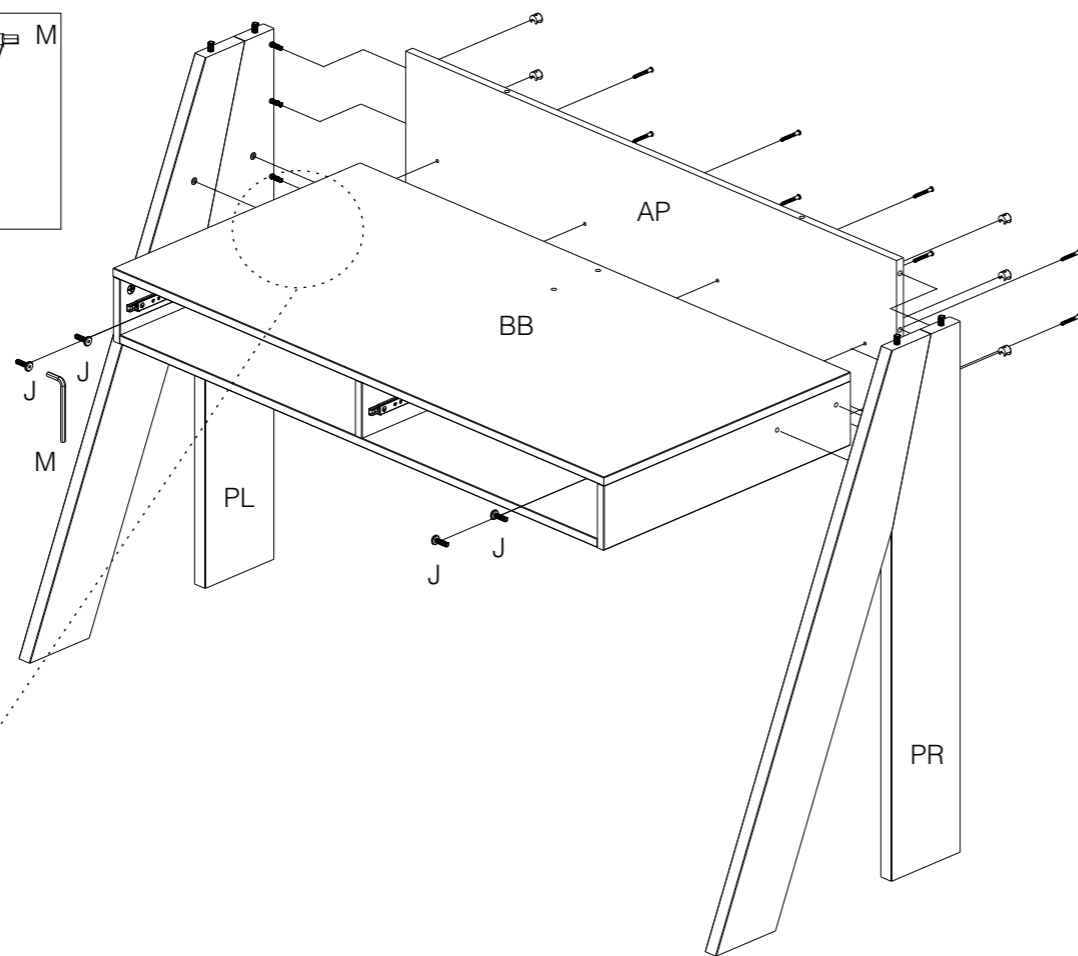
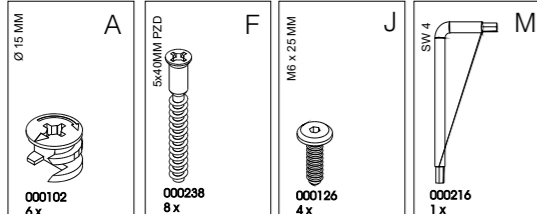

8

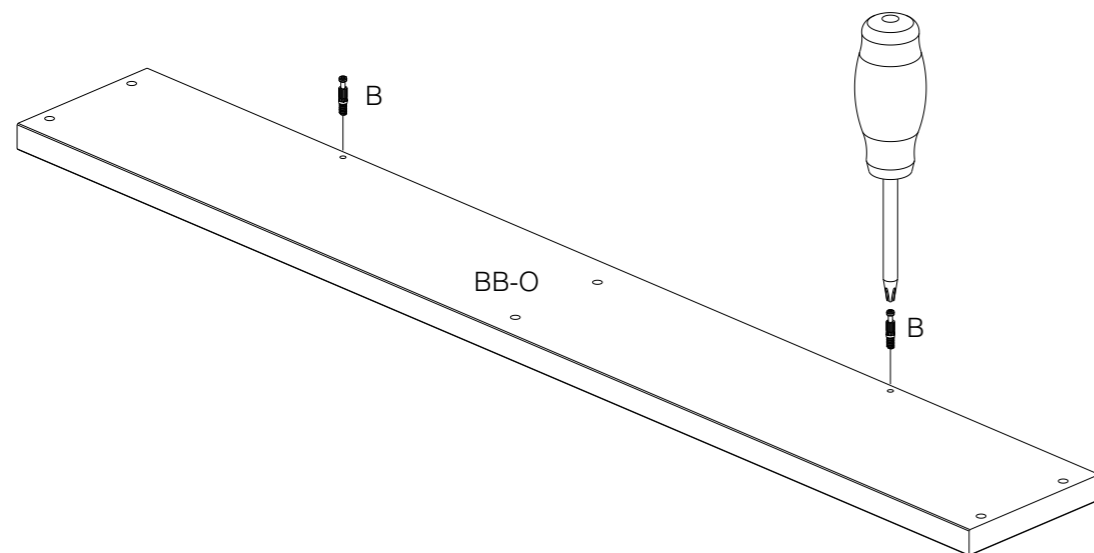
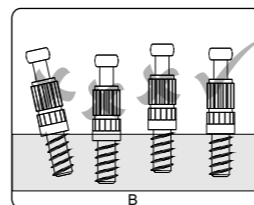
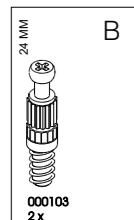

9

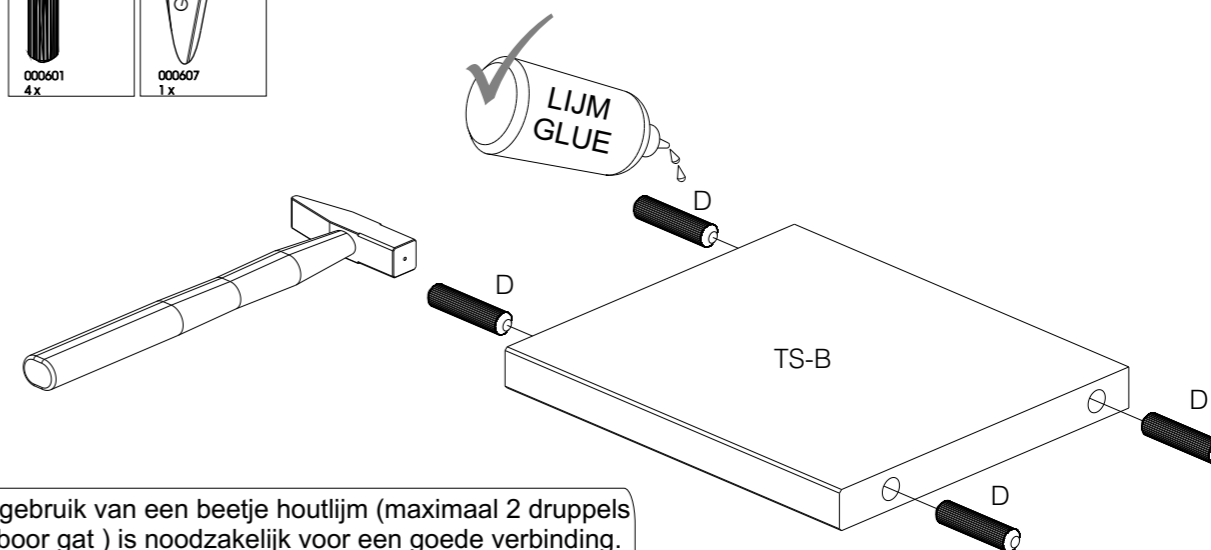
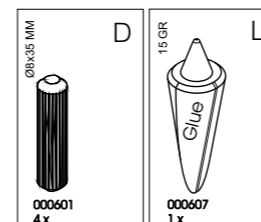

Het gebruik van een beetje houtlijm (maximaal 2 druppels per boor gat) is noodzakelijk voor een goede verbinding.

Verwendung von ein bisschen Holzleim (bis 2 tropfen pro Bohrloch) ist notwendig für eine gute Verbindung.

Il est nécessaire d'utiliser un peu de colle à bois (au maximum deux gouttes pour chaque trou de perçuse) pour assurer un bon assemblage.

The use of a little bit wood glue (up to 2 drops per drill hole) is necessary for proper connection

10

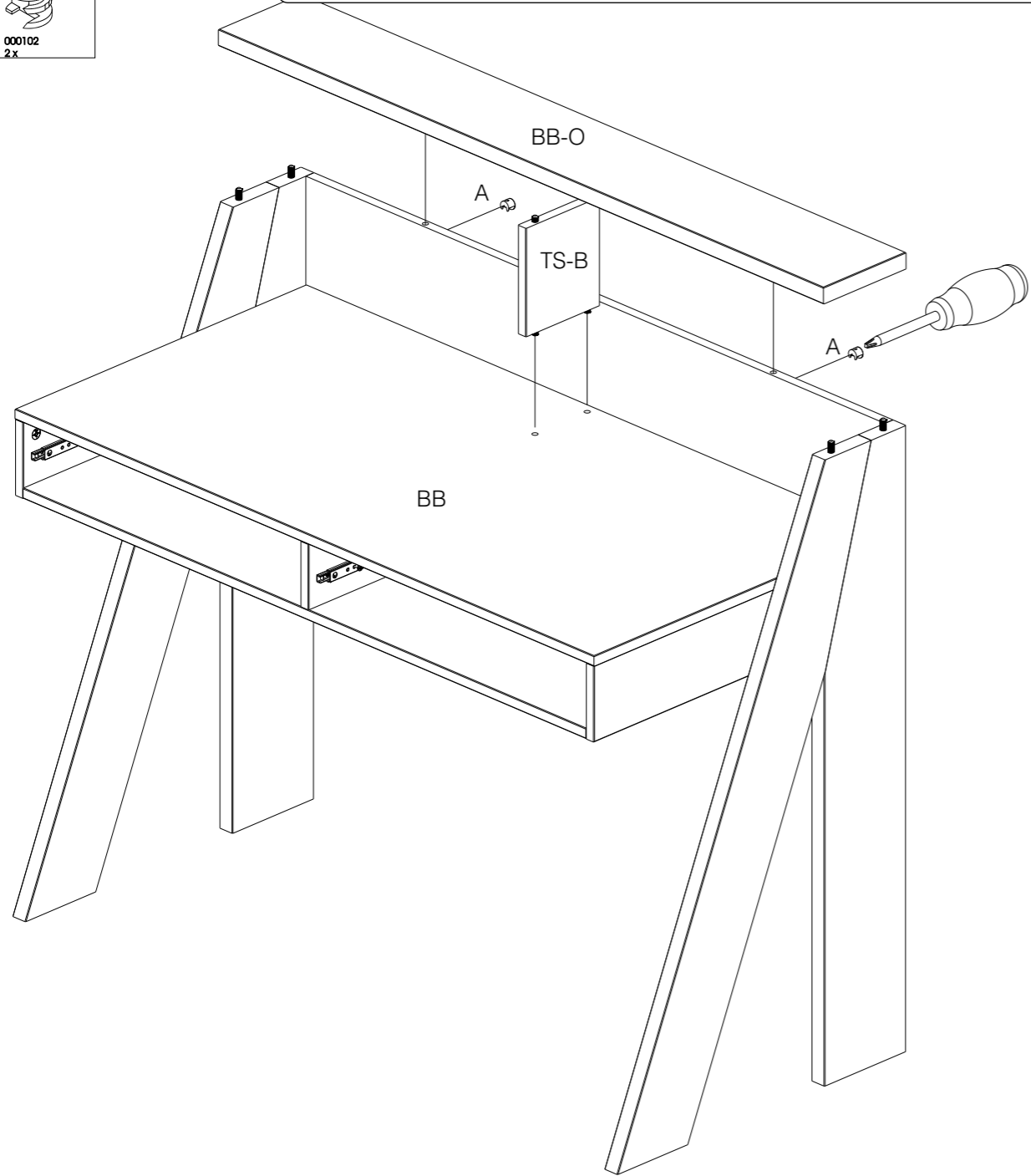
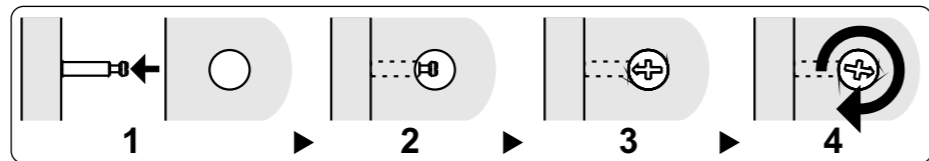
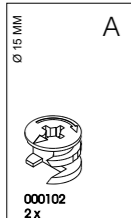

11

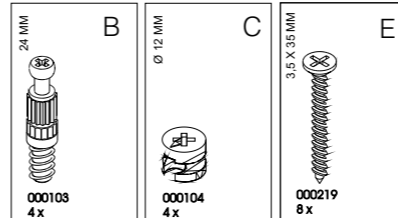

2x

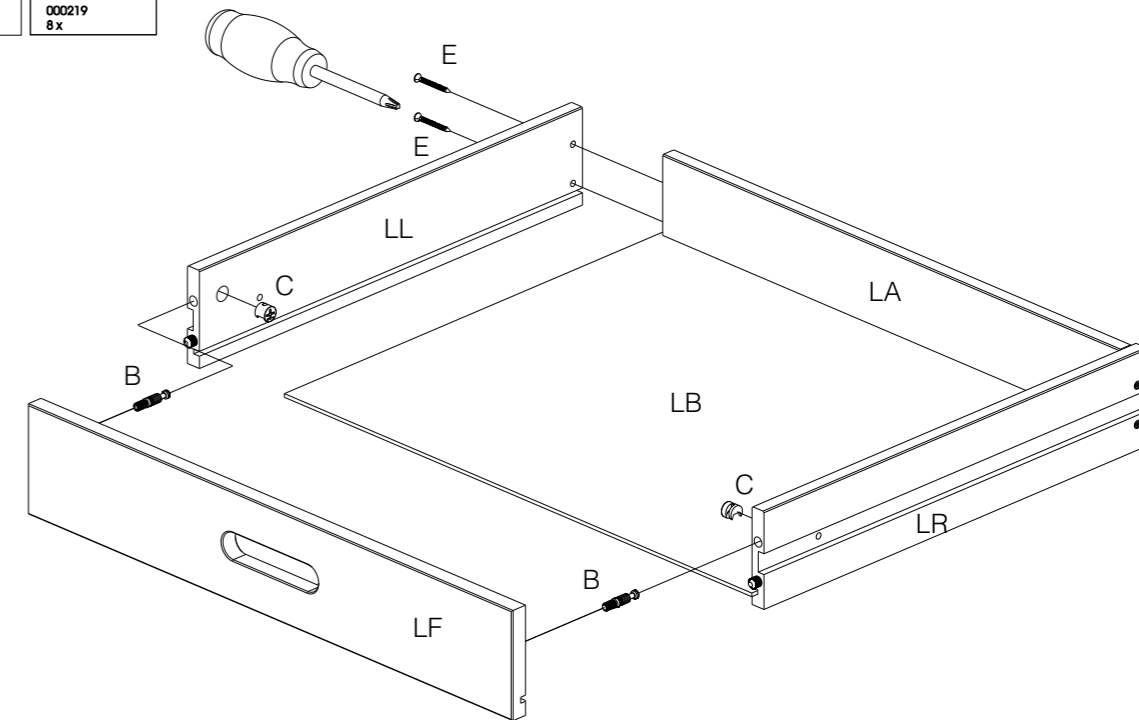

12

