



Front Surround System

YAS-306

Owner's Manual

musicCAST

Read the supplied booklet "Quick Start Guide" before using the unit.

English

EN

Contents

PREPARATION

Supplied items	3
Features	4
Frequently asked questions.....	5
Part names and functions	6
Installation	8
Connecting the unit.....	10
Connecting the unit to a TV	10
Connecting the unit to other devices.....	11

PLAYBACK

Operations.....	12
Listening to the sound from a Bluetooth device.....	16
Using wireless headphones to listen to audio.....	17

NETWORKS

Networks	18
Network functions and the MusicCast CONTROLLER app	18
Connecting to a network	18
Playing back music stored on media servers (PCs/NAS).....	22
Listening to Internet radio.....	23
Playing back music with AirPlay	24
Playing back music stored on mobile devices	25

SETTINGS

Settings	26
Using the TV's remote control to adjust the unit's volume	26
Using an external subwoofer.....	29
Enabling/disabling the auto power standby function	29
Enabling/disabling the network standby function.....	30
Enabling/disabling a wireless (Wi-Fi) connection	30
Enabling/disabling the Bluetooth function.....	31
Updating the unit's firmware	31
Initializing the unit.....	32

APPENDIX

Troubleshooting	33
Specifications	38

About this manual

NOTE

This indicates precautions for use of the product and its feature limitations.

HINT

This indicates supplementary explanations for better use.

Supplied items

Make sure you have received all of the following items.



The unit

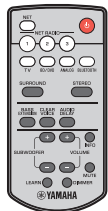

Remote control

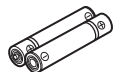

Batteries x 2
(AAA, R03, UM4)

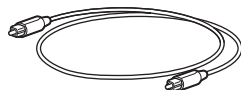

Optical digital audio cable*
(1.5 m [4.9 ft])

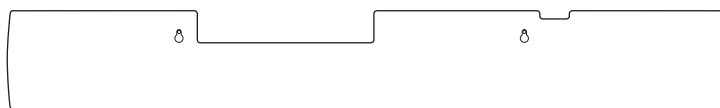

Mounting template
Use when mounting the unit on a wall



Cover (for the TV remote repeater)



Spacers x 2
Use when mounting
the unit on a wall

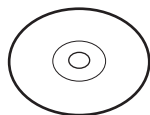

Owner's Manual
CD-ROM



Quick Start Guide



MusicCast
Setup Guide

Preparing the remote control

Peel off the protection sheet before use.

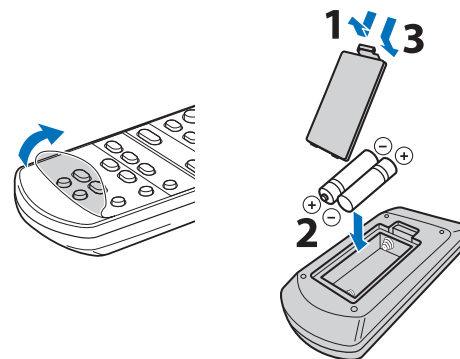

Operating range of the remote control

Operate the remote control within the range as shown below. When the unit is mounted on a wall, point the remote control at the remote control sensor on the top panel (p.9).

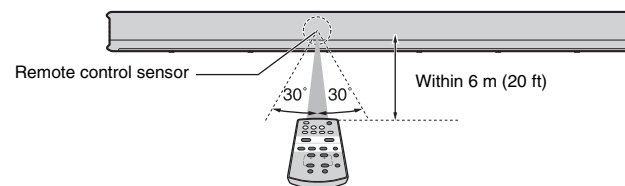

* The China model comes with a coaxial digital audio cable rather than an optical digital audio cable.

Features

This front surround system is easily installed and has a built-in subwoofer for enjoying powerful and realistic sound with connection to a TV or other devices.

- **AIR SURROUND XTREME** 

Enjoy 7.1 channel surround sound, which creates a wide and deep soundstage, as if speakers are positioned not only in front of, but also to the left, right, and behind the listener.

- **Bass extension**

Enjoy powerful bass with Yamaha's exclusive bass boosting technology, Advanced Bass Extension Processing (p. 14).

- **Unrestricted playback of music over a network using MusicCast CONTROLLER** 

The free app for mobile devices*, MusicCast CONTROLLER, allows you to listen to music stored on mobile devices such smartphones, or on servers, or to listen to Internet radio stations and many kinds of major streaming services (p. 18).

This app also allows you to distribute content to other MusicCast-enabled devices for synchronized playback.

The MusicCast CONTROLLER app can also be used to perform such tasks as selecting the input source and adjusting volume.

See the "MusicCast Setup Guide", or visit the Yamaha website for details.

Search for "MusicCast CONTROLLER" on the App Store or Google Play.

- **A function that learns from the TV's remote control**

Use the TV's remote control to turn on and off the unit or adjusting the volume (p.26).

- **Clear voice**

This feature makes speech, such as dialog and narration, clearer (p. 14).

* In this manual, iOS and Android mobile devices are collectively referred to as "mobile devices". The specific type of mobile device is noted in explanations as needed.

Frequently asked questions

The following section covers popular functions and frequently asked questions about the unit.

Q1 **Switching between remote controls is inconvenient. Can I use the TV's remote control to operate the unit?**

A1 Yes. You can use the unit's learning function to "teach" it to respond to commands from the TV's remote control, allowing you to operate the unit using the TV's remote control (p.26).

This function is available only for the IR (infrared) remote control. Check your TV's remote control type.

Q2 **Can I improve the clarity of dialogue?**

A2 Yes. Dialogue in movies, TV news, sports programs, etc., can be made clearer using the "clear voice" function (p.14).

Q3 **Can I operate the unit using a smartphone?**

A3 Yes. The unit can be operated with a smartphone or other mobile device using the free mobile device app, MusicCast CONTROLLER, installed on the device (p.18).

The MusicCast CONTROLLER app allows you to perform such tasks as turning the unit on or off, selecting the input source, and adjusting the volume.

Q4 **Can headphones be used?**

A4 Yes. *Bluetooth* wireless headphones can be used (p.17).

Q5 **Can sound playing via the unit be played on another audio device at the same time, or vice versa?**

A5 Yes. Sound from one MusicCast-enabled audio device can be played on another MusicCast-enabled audio device at the same time. Note that all devices must support MusicCast.

Tap  in the MusicCast CONTROLLER app's Rooms screen, and follow the on-screen instructions to set up the master room (the source device) and to link other rooms (devices to which audio is distributed) with the master room. Refer to the supplied MusicCast Setup Guide, or visit Yamaha's website for details.

Q6 **How can music content stored on a smartphone be played via the unit?**

A6 Choose one of the following methods.

Connecting via Bluetooth (p.16)

This method is useful for playing music content stored on a smartphone or other mobile device without connecting to a network.

Playing music with AirPlay (p.24)

This method is useful for those using an iPhone or other iOS device.

Playing music with the MusicCast CONTROLLER app (p.25)

This method is useful for playing music content stored on a smartphone or other mobile device on which the MusicCast CONTROLLER app is installed.

Q7 **Can Internet radio be played?**

A7 Yes. Use the MusicCast CONTROLLER app's Net Radio feature (p.23).

Part names and functions

The unit (front panel/top panel)

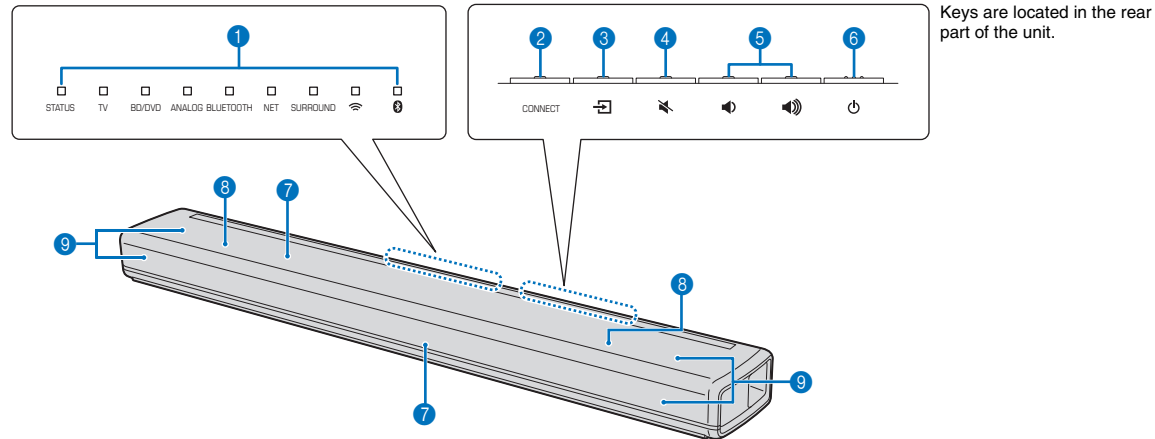

1 Indicators

The indicators on the top panel flash or glow, to show the operation and setting status. In this manual, illustrations of the nine in-line indicators are used for explanation as necessary.

□ : Off ■ : Glows ☀ : Flashes

Example: When the STATUS indicator glows, and the Wi-Fi indicator flashes

■ □ □ □ □ □ □ ☀ □

2 CONNECT key

Use to connect the unit to a network using the MusicCast CONTROLLER app (p.19).

3 [input] key

Select an input source to be played back (p.12).

4 [mute] key

Mute the audio output. Press the key again to unmute (p.13).

5 [volume +/-] keys

Adjust the volume (p.13).

6 [power] key

Turn on or off the unit (p.12).

HINT

- The unit may automatically turn off when the auto power standby function is enabled (p.29).

7 Remote control sensors

Receive infrared signals from the remote control of the unit (p.3) or TV's remote control (p.8). The remote control sensors are located on the front panel and on the top panel of the unit (p.8, 9).

8 Dual built-in subwoofers

The built-in subwoofers are located in the top part of the unit.

9 Speakers

The unit (rear panel)

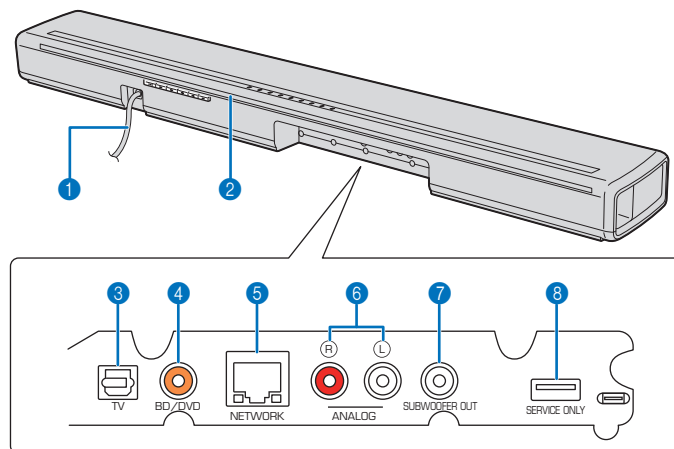

1 Power cable

For connecting to an AC wall outlet (p. 10).

2 TV remote repeater

Used to transmit signals from the TV's remote control, received by the unit's remote control sensor, to the TV (p. 8).

3 TV input jack

For connecting to a TV with an optical digital audio cable (p. 10).

4 BD/DVD input jack

For connecting to a playback device, such as a Blu-ray Disc (BD) player, with a coaxial digital audio cable (p. 11).

5 NETWORK jack

For connecting to a network with a network cable (p. 18).

6 ANALOG input jacks

For connecting to an external device with a stereo cable (p. 10, 11).

7 SUBWOOFER OUT jack

For connecting to an external subwoofer with an RCA mono cable (p. 29).

8 SERVICE ONLY jack

Used only for after-sales servicing. This jack is not normally used.

Installation

The unit can be installed on a TV stand or mounted on a wall (p.9).

It is equipped with remote control sensors positioned to support installation on a TV stand or mounting on a wall.

Installing the unit on a TV stand, etc.

Position the unit so that the keys are on the far side of the unit.

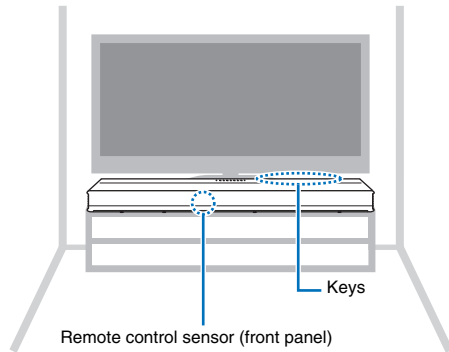

Cautions

- Do not stack the unit and a BD player or other device directly on each other. Doing so may cause a malfunction due to vibrations.
- Do not hold the speaker portion (fabric parts) on the front and the top of the unit.
- The unit contains non-magnetic shielding speakers. Do not place magnetically sensitive items (hard disk drive, etc.) near the unit.
- Depending on your installation environment, it may be better to connect the unit and external devices before installing the unit.

About the TV remote repeater

The unit receives signals from the TV's remote control via the remote control sensor located on the front panel. It then transmits these signals from the TV remote repeater located on the rear panel.

Caution

Position the unit more than 5 cm (2 in) away from the TV to ensure proper transmission of signals from the remote control to the remote control sensor on the TV.

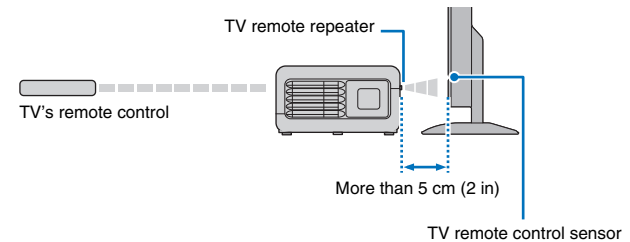

HINT

- This function is available only when the TV's remote control uses infrared signals.
- The TV's remote control can be used even when the unit is turned off as long as the unit's power cable is plugged into an AC wall outlet.

Mounting the unit on a wall

Cautions

- When mounting the unit on a wall, all installation work must be performed by a qualified contractor or dealer. The customer must never attempt to perform this installation work. Improper or inadequate installation could cause the unit to fall, resulting in personal injury.
- To avoid falling the unit, attach the unit to a dry wall.
- Make sure you use commercially available screws that can support the weight of the installation (specified in Step 2 on the right). Using clamps other than specified screws, such as short screws, nails, and two-sided tape, may cause the unit to fall.
- Fix the cables in place where they will not become loose. If your foot or hand accidentally gets caught on a loose cable, the unit may fall.
- Do not lean on the unit or apply excessive force to the top of the unit. Doing so may cause the unit to fall.
- Check that the unit is fixed securely after the installation. Yamaha will bear no responsibility for any accidents caused by improper installations.

Mount the unit on the wall so that the keys face upwards.

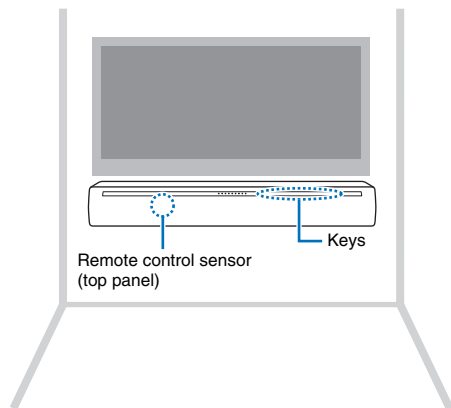

How to mount the unit on the wall

1 Attach the mounting template on a wall and mark for the screw holes.

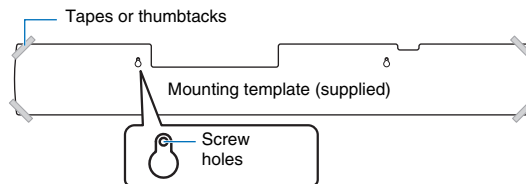

2 Remove the mounting template from the wall, then install commercially available screws (as illustrated below) at the points marked on the wall.

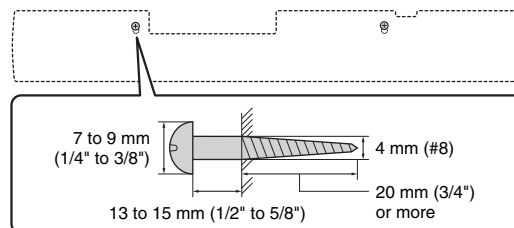

3 Peel off the backing paper from the spacers and attach the adhesive face to the unit as illustrated below.

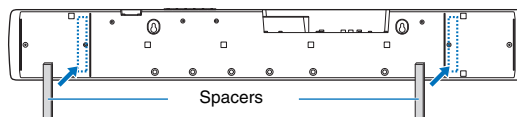

4 Hang the unit on the screws.

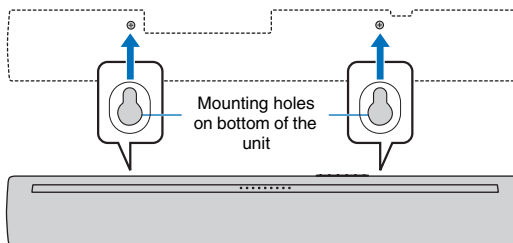

Using the supplied cover (for the TV remote repeater)

When the unit is mounted on a wall, the TV remote repeater may appear white. If this presents a distraction while watching TV, attach the supplied cover to the TV remote repeater.

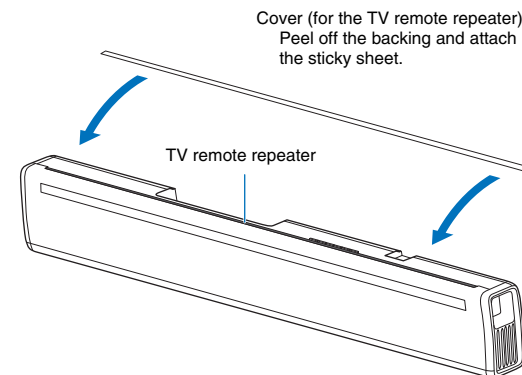

Connecting the unit

The way in which the unit is connected will vary depending upon the type of jacks with which the TV or playback devices (BD/DVD player, etc.) are equipped, and how the TV and playback devices are connected. Refer to the connection examples on pages 10 and 11 to connect the unit.

- 1 Be sure that the unit's power cable is not plugged into an AC wall outlet.**
- 2 Refer to the connection examples on pages 10 and 11 to connect the unit to a TV and playback devices.**

To connect the unit using the supplied optical digital audio cable, remove the cap, confirm orientation, and then plug it firmly into the TV input jack.



HINT

- Connect the supplied optical digital audio cable to the TV input jack, a coaxial digital audio cable to the BD/DVD input jack, and a stereo cable to the ANALOG input jacks.

- 3 Plug the unit's power cable into an AC wall outlet.**
- 4 Set TV volume as low as possible, or disable output from the TV's built-in speaker(s).**

Caution

Do not use excessive force when inserting the cable plug. Doing so may damage the cable plug or terminal.

HINT

- If a setting to disable the speaker output is not available on your TV in step 4, you may disable it by connecting headphones to the headphones jack on the TV. For details, refer to the manuals of the TV.
- The TV and BD/DVD input jacks support the following audio signals.
 - PCM (2 channel)
 - Dolby Digital (up to 5.1 channel)
 - DTS Digital Surround (up to 5.1 channel)

Connecting the unit to a TV

Connection method 1: Connect the unit to a TV

A If the TV has an optical audio output jack

Connect one end of the supplied optical digital audio cable to the unit's TV input jack, and the other to the optical digital audio output jack on the TV.

B If the TV has no optical audio output jack

Use an optional stereo cable to connect the unit's ANALOG input jacks to the analog audio output jacks on the TV.

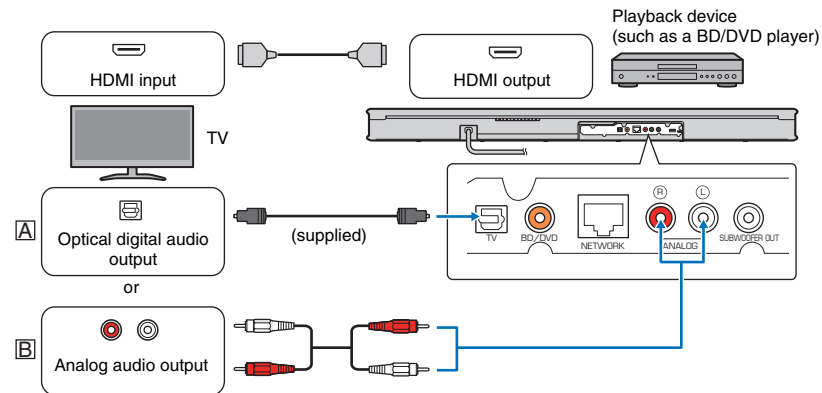

To watch TV or play content from other devices

Change the TV's input source	When watching TV	Switch to the input source for watching TV (select the same input source used before the unit was connected to the TV).
	When playing content from a device	Switch to the input source for the BD/DVD player or other device.
Select the unit's input source		Press the input keys on the unit's remote control to change the unit's input source. A: TV B: ANALOG NOTE • When sound from the TV cannot be output in a digital audio format (Dolby Digital or DTS Digital Surround), be sure that the TV's digital audio output is set to PCM (2ch).

Connection method 2: Connect the unit to a playback device (BD/DVD player, etc.)

Use this method to connect the unit to a playback device when it cannot be connected to the TV as explained with method 1 because the TV has no optical digital audio output jack or analog audio output jacks.

This method can also be used to connect the unit to a playback device, after it has been connected to the TV, when sound from a BD/DVD player or other device connected to the TV is not output as surround sound.

A If the playback device has an optical digital audio output jack

Connect one end of the supplied optical digital audio cable to the unit's TV input jack, and the other to the optical digital audio output jack on the playback device.

B If the playback device has no optical digital audio output jack

Connect one end of an optional coaxial digital audio cable to the unit's BD/DVD input jack, and the other to the coaxial digital audio output jack on the playback device.

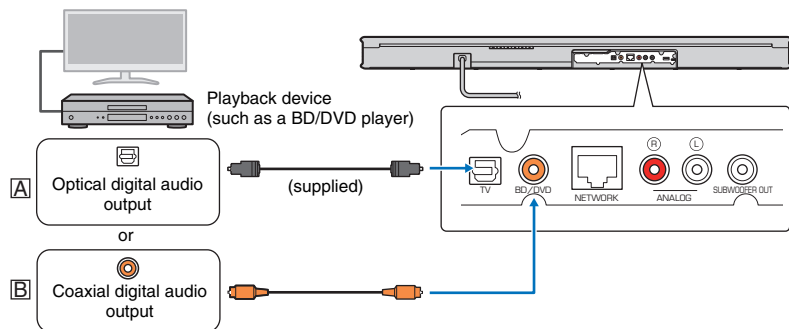

To watch video from a playback device connected to the TV

Change the TV's input source	Switch to the input source for the BD/DVD player or other playback device connected to the TV.
Select the unit's input source	Press the input keys on the unit's remote control to change the unit's input source.

Connecting the unit to other devices

Connect devices such as CD/DVD players or game consoles to the unit for dynamic sound playback. Use an optical digital audio cable, coaxial digital audio cable, or stereo cable to connect audio output jack(s) on each playback device to input jack(s) on the unit.

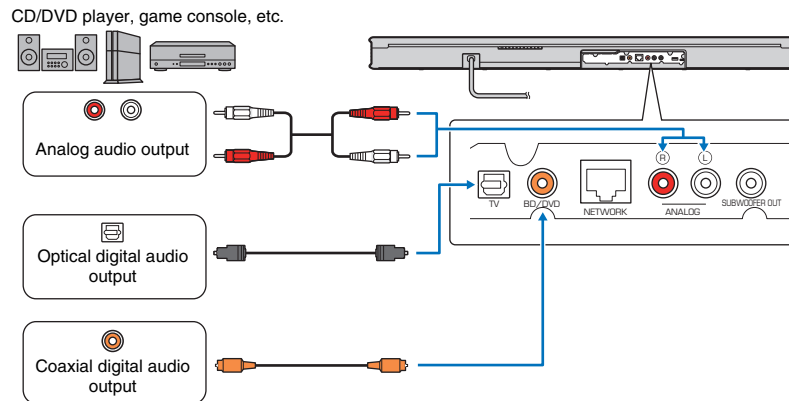

To watch video from an external device

Change the TV's input source	Switch to the input source for the external device.
Select the unit's input source	To play sound from an external device, press the input key (ANALOG, TV, or BD/DVD) that corresponds to the jack(s) on the unit to which the external device is connected. NOTE <ul style="list-style-type: none"> When sound from the external device cannot be output in a digital audio format (Dolby Digital or DTS Digital Surround), be sure that the device's digital audio output is not set to PCM (2ch). If volume can be adjusted using the device connected to the unit's ANALOG input jacks, set that device's volume to the same level as that of other devices connected to the unit's TV and BD/DVD input jacks to prevent volume from being louder than expected.

Operations

Remote control signal transmitter

Transmits infrared signals.

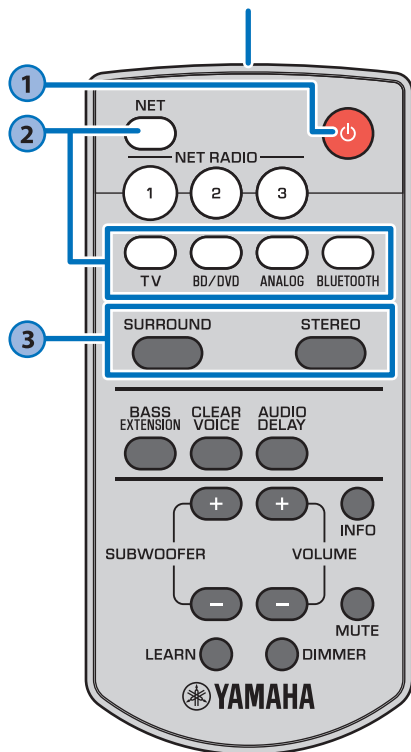

1

⏻ (power) key

Turns on or off the unit.

Turned on



The indicator for the last input source selected glows green.

Indicates the surround setting, and network (p. 18) or *Bluetooth* (p. 16) connection status.

Turned off (network standby function enabled, p.30)

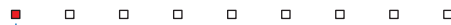

Glow (red)

Turned off

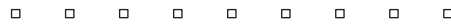

HINT

- When the unit is turned on for the first time after purchase, the  indicator flashes slowly.



While the  indicator is flashing, network settings from your iOS device (an iPhone, etc.) can be applied to the unit to connect the unit to a wireless network. For details on settings, see "Playing back music with AirPlay" (p.24). Press any key on the remote control to cancel this function if it will not be used.

The  indicator does not flash if the unit's NETWORK jack is connected to a router using a cable (wired connection).

2

Input keys

Select an input source to be played back.

- TV** TV audio or sound from a device connected to the unit's TV input jack
- BD/DVD** Sound from a device connected to the BD/DVD input jack
- ANALOG** Sound from a device connected to the ANALOG input jacks
- BLUETOOTH** Sound from a *Bluetooth* connected device
- NET** Audio acquired via a network
The last audio source listened to is selected when the NET key is pressed.

The indicator for the selected input source glows. (Example: when TV is selected)



HINT

- To play sound from the device connected to the TV or to watch video from the device, set the TV's input source to the playback device.
- For playback from a *Bluetooth* device, refer to page 16. For audio playback via a network, refer to pages 22 to 25.

3

SURROUND and STEREO keys

Switch between surround and stereo (2 channels) playback. When surround playback is selected, you can enjoy a realistic sound effect using Yamaha's exclusive AIR SURROUND XTREME.

SURROUND  Glows (surround playback)

STEREO  Off (stereo playback)

HINT

- Dolby Pro Logic II is used when 2-channel stereo signal is played in surround.
- The TV PROGRAM, MOVIE, MUSIC, SPORTS, or GAME surround mode can be selected using the MusicCast CONTROLLER app (p. 19) installed on a mobile device.

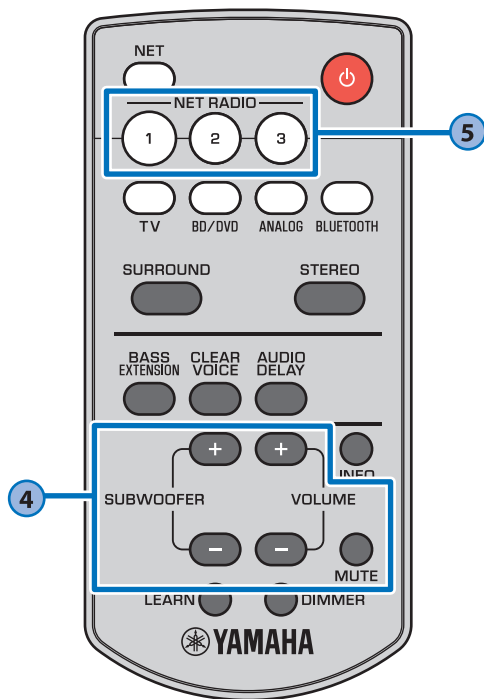

4

SUBWOOFER (+/-) keys

Adjust the volume of the subwoofer.



VOLUME (+/-) keys

Adjust the volume of the unit.

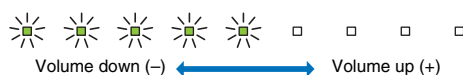

MUTE key

Mute the audio output. Press the key again to unmute.

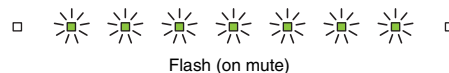

5

NET RADIO (1-3) keys

Assign audio input via a network (Internet radio stations, music files stored on media servers, etc.) to the NET RADIO key.

Assign a station

- 1 Play the desired Internet radio station (p.22 to 25).
- 2 Hold down the NET RADIO 1, 2, or 3 key for more than 3 seconds.



Tune-in to an assigned Internet radio station

- 1 Press the NET RADIO 1, 2, or 3 key to which the desired Internet radio station has been assigned.

HINT

- When an Internet radio station is assigned to the NET RADIO 1, 2, or 3 key on the remote control, the same station is also registered with No. 1, 2, or 3 in the MusicCast CONTROLLER app's "Favorites". When an Internet radio station is registered with No. 1, 2, or 3 in "Favorites" with the MusicCast CONTROLLER app, the same station is also assigned to the NET RADIO 1, 2, or 3 key on the remote control.

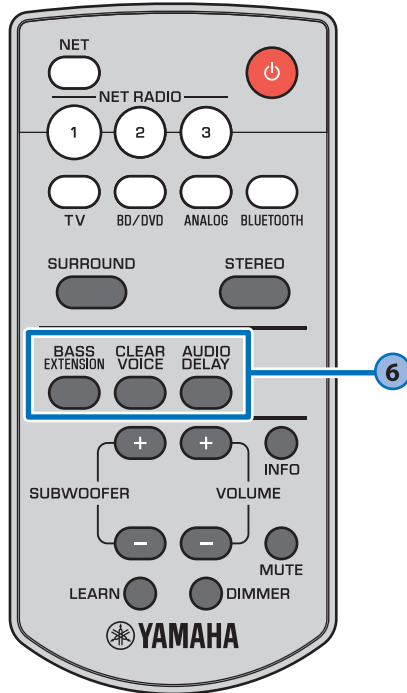

6

BASS EXTENSION key

Enable/disable the bass extension function. When this function is enabled, you can enjoy a powerful bass sound with the Yamaha original bass boost technology “Advanced Bass Extension Processing.”



Enabled: Flashes three times and goes out
 Disabled: Flashes once and goes out

CLEAR VOICE key

Enable/disable the clear voice function. When this function is enabled, human voices such as lines in movies and TV shows, or news and sport commentary, are played clearly.



Enabled: Flashes three times and goes out
 Disabled: Flashes once and goes out

AUDIO DELAY key

Adjust the audio delay to synchronize the sound with the video when the video image on the TV may seem delayed with respect to the sound. Follow the procedure below to adjust the audio delay.

NOTE

- The audio delay cannot be adjusted in the following situations.
 - When *Bluetooth* or *NET* is selected as the input source.
 - When sound is distributed from the unit to one or more other MusicCast-enabled devices.

1 Hold down the AUDIO DELAY key for more than 3 seconds.

The indicator at far left flashes.



2 Press the SUBWOOFER (+/-) key to adjust the audio delay.

Pressing the SUBWOOFER (+) key delays the audio output timing.



3 To finish the adjustment, press the AUDIO DELAY key.

HINT

- The adjustment will be finished automatically if no operations are performed for 20 seconds.

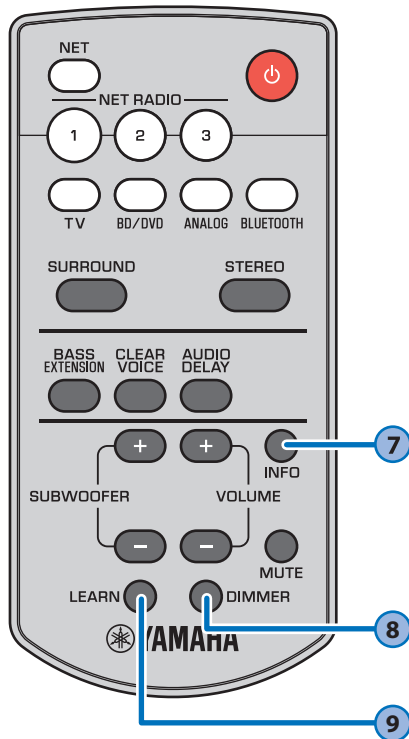

7

INFO key

While the INFO key is held down, status, including the type of audio signal being input and whether the clear voice function is enabled or disabled, can be confirmed by the glowing of indicators.

Type of audio signal being input

DTS Digital Surround



Dolby Digital



Dolby Pro Logic II is used (when 2-channel stereo signal is played in surround)



Unit functions and positioning

The bass extension function is enabled



The clear voice function is enabled



When positioned on top of something, such as a TV stand



When mounted on a wall



HINT

- The unit is able to play the following types of audio signal. The indicators do not glow when analog or PCM audio signal is input.
 - Analog signal
 - PCM (2 channels)
 - Dolby Digital
 - DTS Digital Surround

8

DIMMER key

Change the brightness of the indicators. Each time the key is pressed, the brightness of the indicators changes as follows.

Dim (default setting) → Off → Bright



Indicators glow brightly just after operation and change to the specified brightness after a few seconds.

9

LEARN key

The unit enters learning mode, in which it can learn TV remote control commands (p.26).

Listening to the sound from a *Bluetooth* device

Audio from a *Bluetooth* device, such as a mobile device or a digital music player, can be played over a wireless connection.



NOTE

- Adjust the volume level of the *Bluetooth* device as required.
- When the network standby function (p.30) is enabled, the unit turns on with operation of the *Bluetooth* device.
- Perform *Bluetooth* connection with the device and unit within 10 m (33 ft) of each other.

HINT

- See documentation supplied with your *Bluetooth* device for more information.

- 1 Press the BLUETOOTH key on the unit's remote control to select *Bluetooth* as the input source.**

The BLUETOOTH indicator on the unit glows.



If a *Bluetooth* device has been connected before, the unit will connect to the last connected device when the BLUETOOTH key is pressed. Terminate this connection to connect a new device.

- 2 Enable the *Bluetooth* function on the *Bluetooth* device.**

- 3 Select “YAS-306 xxxxxx Bluetooth”* in the *Bluetooth* device list on the device.**

* If the unit is registered as a MusicCast-enabled device (p. 19), the room name (network name) is displayed.

If a passkey (PIN) is required, enter the number “0000”.

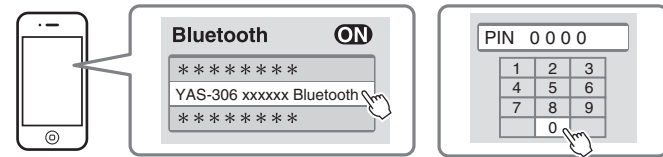

When the connection is established, the  indicator on the unit glows.



The  indicator or a completion message is displayed on the *Bluetooth* device.

- 4 Play back a song on the *Bluetooth* device.**

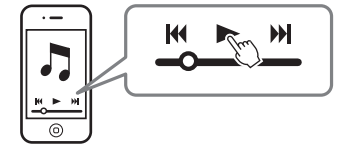

Terminating *Bluetooth* connection

Perform one of the following operations to terminate *Bluetooth* connection.

The  indicator on the unit turns off when the connection is terminated.

- Turn off the *Bluetooth* function on the *Bluetooth* device.
- Press the BLUETOOTH key on the unit's remote control for more than 3 seconds.
- Switch the unit's input source to any input source other than *Bluetooth*.
- Turn off the unit.

Using wireless headphones to listen to audio

Bluetooth wireless headphones can be used to listen to audio played via the unit. Sound is transmitted to the wireless headphones using the MusicCast CONTROLLER app installed on a mobile device.

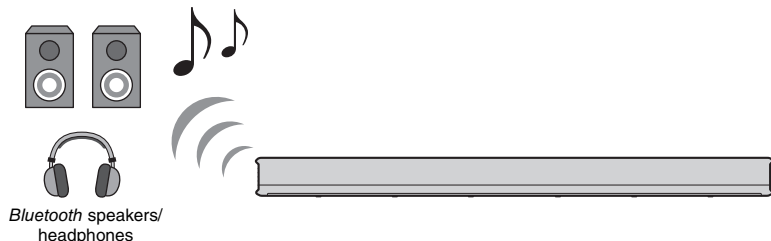

NOTE

- Use a *Bluetooth* device that supports the A2DP profile.
- Audio input using AirPlay, or from a *Bluetooth* device, cannot be transmitted to other *Bluetooth* devices for playback.
- Perform *Bluetooth* connection with the device and unit within 10 m (33 ft) of each other.

HINT

- Audio will also be output from the unit.
- This section uses MusicCast CONTROLLER app screens displayed in English on an iPhone as examples.
- See documentation supplied with your *Bluetooth* device for more information.

- 1 Use the MusicCast CONTROLLER app to connect the unit to a network, and register the unit as a MusicCast-enabled device (p.19).**
- 2 Use the MusicCast CONTROLLER app to play a song (via any device other than a *Bluetooth* device).**
- 3 Configure a *Bluetooth* device (wireless headphones, etc.) for *Bluetooth* connection with the unit.**

- 4 Tap  in the MusicCast CONTROLLER app's playback screen.**



- 5 Tap "Bluetooth Transmission".**

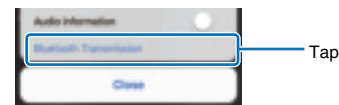

- 6 Enable the *Bluetooth* Transmission function and choose a destination *Bluetooth* device (wireless headphones, etc.).**

When a connection is established, the  indicator on the unit will glow.



- 7 Tap "Done".**

Audio is output from the destination *Bluetooth* device (wireless headphones, etc.).

Terminating *Bluetooth* connection

Perform one of the following operations to terminate *Bluetooth* connection. The  indicator on the unit turns off when the connection is terminated.

- Terminate *Bluetooth* connection from the *Bluetooth* device, or turn off the *Bluetooth* device.
- Disable the MusicCast CONTROLLER app's *Bluetooth* Transmission function.
- Press the BLUETOOTH key on the unit's remote control for more than 3 seconds.
- Turn off the unit.

Networks

Network functions and the MusicCast CONTROLLER app

A network connection allows you to listen to Internet radio stations or music streaming services, and to use AirPlay to play music files, or to play music files stored on your computer (media server) via this unit.

Most playback requires the “MusicCast CONTROLLER” app for mobile devices. Install and use the MusicCast CONTROLLER app on your mobile device to play music files.

Proceed from network connection to playback in the following sequence.

1 Choose a wired network connection (p. 18) or a wireless network connection (p. 19).



2 Use the MusicCast CONTROLLER app to connect the unit to a network, and register the unit as a MusicCast-enabled device (p. 19).



3 Use the MusicCast CONTROLLER app to play music over a network* (p. 22 to 25).

* AirPlay can be used to play music files without using the MusicCast CONTROLLER app.

NOTE

- To use network function, the unit, your PC and mobile device must be connected to the same router.
- When using a multiple SSID router, access to the unit might be restricted depending on the SSID to connect. Connect the unit and mobile device to the same SSID.
- Some security software installed on your computer, or network device settings (such as a firewall), may block the unit’s access to your computer or Internet radio stations. Should this occur, change security software and/or network device settings.
- A network connection cannot be established if the MAC address filter on your router is enabled. Check your router’s settings.
- To configure your router’s subnet mask manually, apply the same subnet used by this unit to all devices.
- Use of a broadband connection is recommended when using Internet services.
- The unit cannot be connected to a network that requires manual setup. Connect the unit to a DHCP-enabled router.

Connecting to a network

Choose a wired or wireless network connection based on your network environment.

Wired network connections

To use a wired network connection, connect the unit to a router via an STP network cable (category 5 or higher straight cable; not supplied).

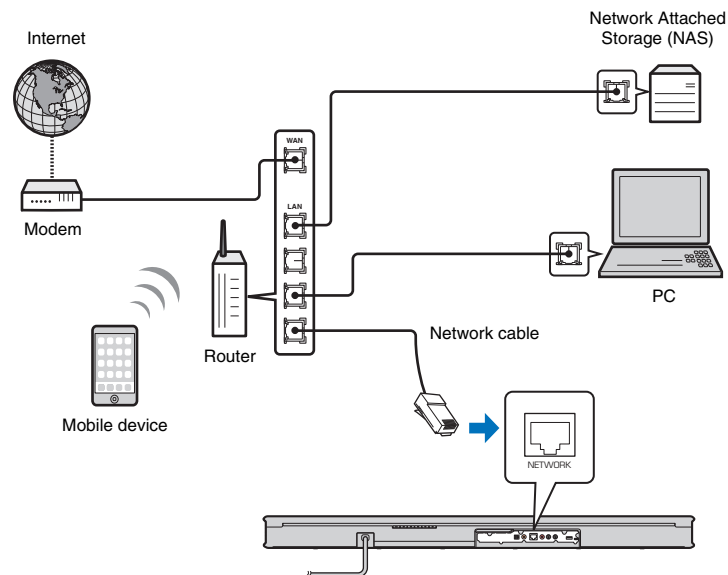

HINT

- If network connections or settings are changed, use the MusicCast CONTROLLER app to connect the unit to a network and register the unit as a MusicCast-enabled device again (p. 19).

Wireless network connections

Connect the unit to a wireless router (access point) to use a network.
Refer to the following for instructions on connecting to a wireless router (access point).

- Using the MusicCast CONTROLLER app (p. 19)
- Applying iOS device (iPhone, etc.) settings to the unit (p.24)

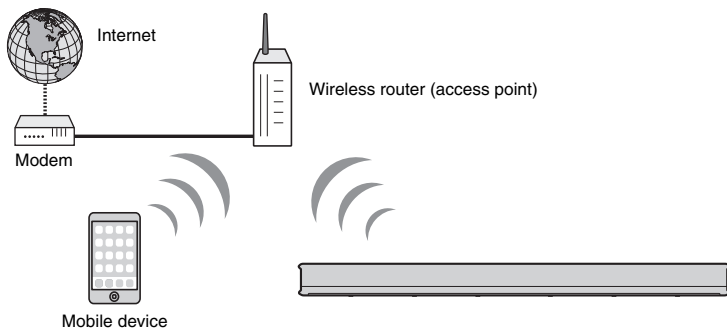

The  indicator on the unit glows when the unit is connected to a wireless network.



NOTE

- If the unit and the wireless router (access point) are too far apart, the unit may not connect to a wireless router (access point). In such case, place them close to each other.

Connecting with the MusicCast CONTROLLER app (registering the unit as a MusicCast-enabled device)

Install the MusicCast CONTROLLER app on your mobile device to connect the unit to a network and register it as a MusicCast-enabled device.

HINT

- Confirm that your mobile device is connected to your home router before beginning.
- This section uses MusicCast CONTROLLER app screens displayed in English on an iPhone as examples.
- MusicCast CONTROLLER app screens and menu labels are subject to change without prior notice.

1 Install the MusicCast CONTROLLER app on your mobile device, and open the app.

Search for “MusicCast CONTROLLER” on the App Store or Google Play.

2 Tap “Setup”.

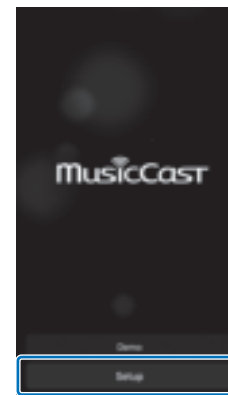

3 Turn on the unit, and then tap “Next”.

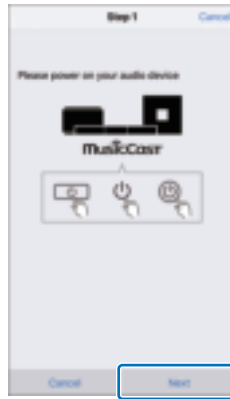

4 Hold down the CONNECT key until the indicator on the unit starts flashing.

5 Follow the on-screen instructions to configure network settings.

HINT

- When a screen like that below is displayed, follow the on-screen instructions to configure network settings.

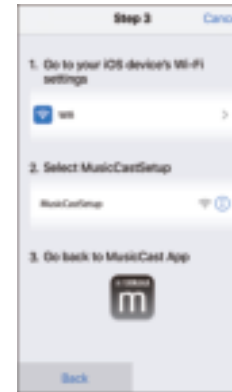

1. Use the Home button on your mobile device to return to the Home screen.
2. Select “Wi-Fi” from “Settings”.
3. Select “MusicCastSetup” from “CHOOSE A NETWORK...”.
4. Use the Home button to return to the MusicCast CONTROLLER app.

- When a screen like that at left below is displayed, select the network to which the unit will be connected and enter the router’s password (encryption key). The router’s password (encryption key) is often noted on the router itself. Refer to documentation supplied with the router for details.



6 To register the unit as a MusicCast-enabled device, configure the following items.

- Location name (“home”, “John’s house”, etc.)
- Name and photo of the room where the unit is installed

The location name, and the name and photo of the room where the unit is installed can be changed later.



Network connection with the MusicCast CONTROLLER app is now complete, and the unit has been registered as a MusicCast-enabled device.

HINT

- If a different MusicCast-enabled device is already registered with the MusicCast CONTROLLER app, tap  (Setup) in the room selection screen, and then select “Add New Device” to add the unit to the app.

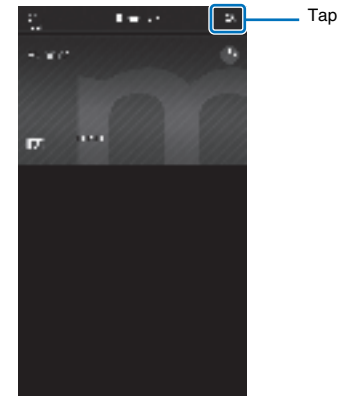

Playing back music stored on media servers (PCs/NAS)

You can play back music files stored on your PC or DLNA-compatible NAS via the unit.

NOTE

- The audio may be interrupted while using the wireless network connection. In this case, use the wired network connection.

Supported File formats

File	Sampling frequency (kHz)	The number of channels	Gapless playback
WAV*	32 to 192	2	✓
MP3	8 to 48	2	—
WMA	8 to 48	2	—
MPEG-4 AAC	8 to 48	2	—
FLAC	32 to 192	2	✓
ALAC	32 to 96	2	✓
AIFF	32 to 192	2	✓

* Linear PCM format only

NOTE

- To play back FLAC files stored on a PC or NAS, you need to install server software that supports sharing of FLAC files via DLNA on your PC or use a NAS that supports FLAC files.
- Digital Rights Management (DRM) contents cannot be played back.

Media sharing setup

To play back music files stored on your PC or DLNA-compatible NAS, first you need to configure the media sharing setting on each music server.

For a PC with Windows Media Player installed

This unit supports Windows Media Player 11 or later. This section explains Windows Media Player 12 setup as an example.

NOTE

- Operation may vary depending upon your PC or settings. Refer to documentation provided by your PC's manufacturer or Windows Media Player Help for details.

- 1 Start Windows Media Player 12 on your PC.
- 2 Select "Stream", then "Turn on media streaming".
- 3 Click "Turn on media streaming".
- 4 Select "Allowed" from the drop-down list next to the unit's model name.
- 5 Click "OK" to exit.

For a PC or a NAS with other DLNA server software installed

Refer to documentation supplied with the device or software and configure the media sharing settings.

Playing music files

Use the MusicCast CONTROLLER app installed on your mobile device to play music files.

NOTE

- Register the unit as a MusicCast-enabled device (p. 19) before playing music files.

- 1 Use the MusicCast CONTROLLER app to select the unit's room (Room1, etc.).
- 2 Tap  (Server).
- 3 Follow the on-screen instructions to select a song.

HINT

- When a music file is registered with No. 1, 2, or 3 in "Favorites" with the MusicCast CONTROLLER app, the registered music file can be played with the NET RADIO 1, 2, or 3 key on the remote control.

Listening to Internet radio

You can listen to Internet radio stations from all over the world.

NOTE

- You may not be able to receive some Internet radio stations.
- The unit uses the vTuner Internet radio station database service. This service may be discontinued without notice.

Playback of Internet radio

Use the MusicCast CONTROLLER app installed on your mobile device to select an Internet radio station.

NOTE

- Register the unit as a MusicCast-enabled device (p.19) before listening to Internet radio.

- 1 Use the MusicCast CONTROLLER app to select the unit's room (Room1, etc.).**
- 2 Tap  (Net Radio).**
- 3 Select a station from "Locations", "Genres", etc.**

HINT

- When an Internet radio station is registered with No. 1, 2, or 3 in "Favorites" with the MusicCast CONTROLLER app, the registered Internet radio station can be played with the NET RADIO 1, 2, or 3 key on the remote control.

Using the MusicCast CONTROLLER app to bookmark a station

- 1 Select the desired Internet radio station.**
- 2 Tap  in the playback screen, and then tap "Add Bookmark".**



Tuning into registered Internet radio stations

- 1 Tap "Bookmarks", and then tap "My_Favorites" to select the desired Internet radio station.**

Playing back music with AirPlay

The AirPlay function allows you to play back iTunes or iPod music on the unit via network.

HINT

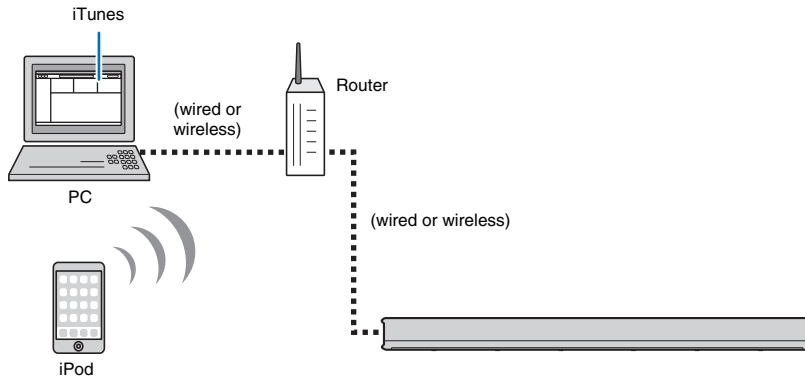

- This section describes "iPod touch", "iPhone" and "iPad" as the "iPod". "iPod" refers to "iPod touch", "iPhone" and "iPad", unless otherwise specified.



NOTE

- AirPlay works with iPhone, iPad, and iPod touch with iOS 4.3.3 or later, Mac with OS X Mountain Lion or later, and Mac and PC with iTunes 10.2.2 or later.

HINT

- When the unit is turned on for the first time after purchase, the  indicator flashes slowly. While the  indicator is flashing, network settings from your iOS device (an iPhone, etc.) can be applied to the unit to connect the unit to a wireless network. The  indicator does not flash if the unit's NETWORK jack is connected to a router using a cable (wired connection).



Display Wi-Fi settings on the iOS device and select the unit from "SETUP A NEW AIRPLAY SPEAKER...".

Example



When the following screen is displayed, select the network (access point) to which the unit will be connected.

Example

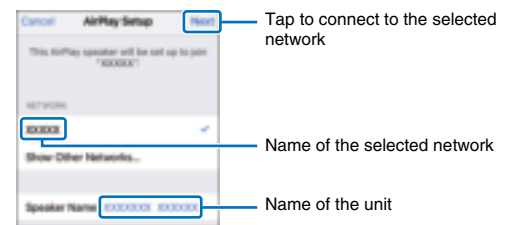

If the unit is connected to a network using the MusicCast CONTROLLER app, network settings will be changed to those of the MusicCast CONTROLLER app.

Playback of iTunes/iPod music contents

Follow the procedure below to play back iTunes/iPod music contents on the unit.

1 Turn on the unit, and start iTunes on the PC or display the playback screen on the iPod.

If the iTunes/iPod recognizes the unit, the AirPlay icon () appears.

iTunes (example)



iPod (example)



NOTE

- If the icon does not appear, check whether the unit and PC/iPod are connected to the router properly.

2 On the iTunes/iPod, click (tap) the AirPlay icon and select the unit as the audio output device.

iTunes (example)

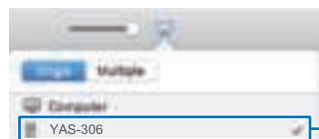

iPod (example)



The unit

3 Select a song and start playback.

To operate playback, use the Music app on the iPod or iTunes on the PC.

HINT

- When the network standby function (p.30) is enabled, the unit automatically turns on when iTunes/iPod playback begins.
- You can adjust the unit's volume from the iTunes/iPod during playback.

Caution

When you use iTunes/iPod controls to adjust volume, the volume may be unexpectedly loud. This could result in damage to the unit or speakers. If the volume suddenly increases during playback, stop playback on the iTunes/iPod immediately.

Playing back music stored on mobile devices

Use this function to play music stored on your mobile device over a network.

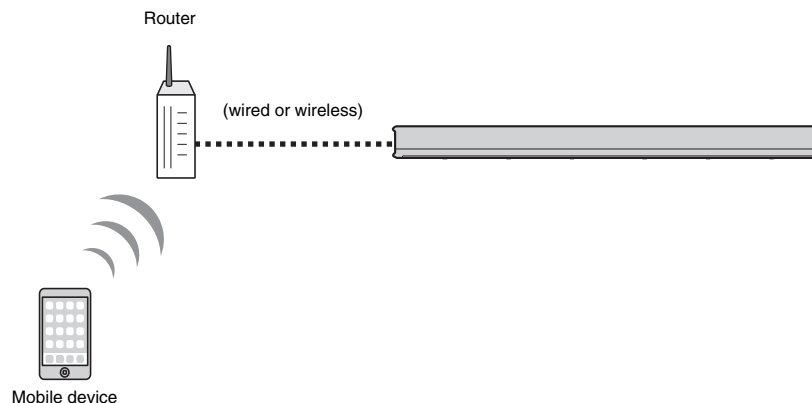

Using a mobile device to play songs

Use the MusicCast CONTROLLER app installed on your mobile device to operate playback.

NOTE

- Register the unit as a MusicCast-enabled device (p.19) before playing music files.

1 Use the MusicCast CONTROLLER app to select the unit's room (Room1, etc.).

2 Tap .

3 Select a song from "Playlists", "Artists", etc.

Caution

When you use mobile device controls to adjust volume, the volume may be unexpectedly loud. This could result in damage to the unit or speakers. If the volume suddenly increases during playback, stop playback on the mobile device immediately.

Settings

Using the TV's remote control to adjust the unit's volume

The unit can be “taught” to read signals from a TV's remote control. This allows the TV and unit to be turned on or off simultaneously, or the volume to be adjusted, using the TV's remote control.

NOTE

- This function is available only if the TV's remote control uses infrared (IR) signal. A remote control that uses radio signals cannot be used.

For cable or satellite set-top box users

Use the TV's remote control (not the remote control for the cable or satellite set-top box) to teach the unit TV remote control commands.

Once the unit is taught TV remote control commands, the remote control for the cable or satellite set-top box can be used to operate the unit.

1 Turn off the unit and the TV.

If the TV is on while the unit is learning TV remote control commands, light emitted by the TV may interfere with the learning process.

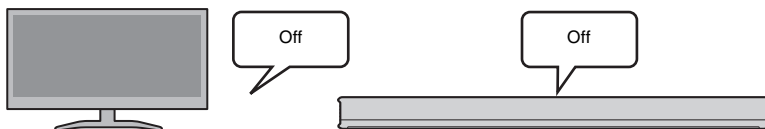

2 Point the unit's remote control at the appropriate remote control sensor on the unit, and hold down the LEARN key for at least 3 seconds.

The unit will enter learning mode. The unit's indicators will flash as shown below.



NOTE

- Only the TV's remote control and the keys on the unit are used for steps 3 through 6. The unit's remote control is not used.
- If the unit has already learned functions, indicators will glow as follows.

Mute: BD/DVD

Volume (-): ANALOG

Volume (+): BLUETOOTH

Power: NET

If the unit is taught TV remote control commands by following steps 3 through 7, all previous learning will be cleared. To prevent this, press the LEARN or (power) key on the unit's remote control to cancel learning mode.

- Learning takes place all at once. Be sure to teach the unit all necessary TV remote control commands at once, as attempting to teach the unit additional commands later will clear all previous learning.

3 Teach the unit the TV remote control's "Mute" command.

3-1 Press the key on the unit.

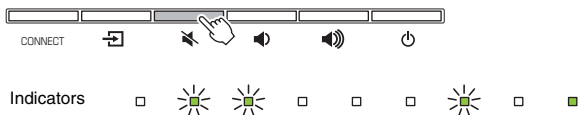

3-2 Point the TV's remote control at the remote control sensor on the unit, hold down the mute key for at least 1 second, and then release it for at least 1 second. Perform this operation twice.

The position of the remote control sensor varies depending upon the installation of the unit (p.8, 9).

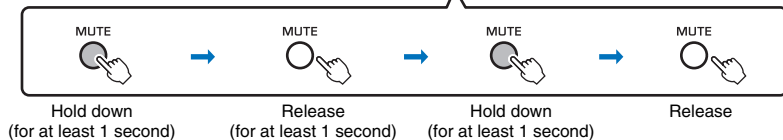
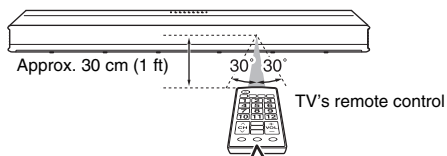

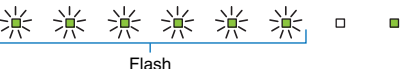
Result	Bleep/buzzer	Indicators
Successfully learned	Once	 Glow
Failed to learn Repeat from Step 3-1.	Twice	 Flash

Troubleshooting the unit's failure to learn commands

- ✓ Is the TV turned off?
- ✓ Is direct sunlight or fluorescent light striking the unit and interfering with operation?
- ✓ Are you using the TV's remote control for Steps 3 through 6? (The unit's remote control is not used.)
- ✓ Are you using the remote control within the range indicated above?
- ✓ Are you holding down keys on the TV's remote control for at least 1 second, and then releasing them for at least 1 second?

If the unit fails to learn commands even after checking all of the above, hold down and release the key on the TV's remote control three times.

4 Teach the unit the TV remote control's "Volume (-)" command.

4-1 Press the key on the unit.

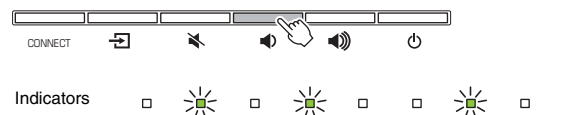

4-2 Point the TV's remote control at the remote control sensor on the unit, hold down the volume (-) key for at least 1 second, and then release it for at least 1 second. Perform this operation twice.

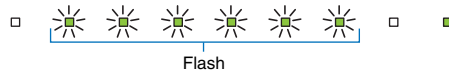
Result	Bleep/buzzer	Indicators
Successfully learned	Once	 Glow
Failed to learn Repeat from Step 4-1.	Twice	 Flash

5 Teach the unit the TV remote control's "Volume (+)" command.

5-1 Press the key on the unit.

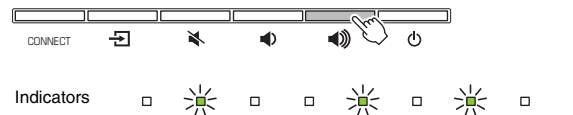

5-2 Point the TV's remote control at the remote control sensor on the unit, hold down the volume (+) key for at least 1 second, and then release it for at least 1 second. Perform this operation twice.

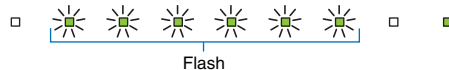

Result	Bleep/buzzer	Indicators
Successfully learned	Once	 Glow
Failed to learn Repeat from Step 5-1.	Twice	 Flash

6 Teach the unit the TV remote control's "Power" command.

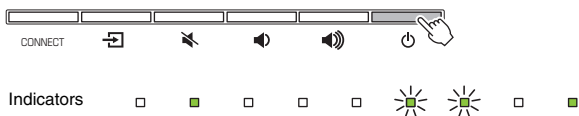
6-1 Press the  key on the unit.



6-2 Point the TV's remote control at the remote control sensor on the unit, hold down the power key for at least 1 second, and then release it for at least 1 second. Perform this operation twice.

Result	Bleep/buzzer	Indicators
Successfully learned	Once	 Glow
Failed to learn Repeat from Step 6-1.	Twice	 Flash

7 To finish the learning mode, press the LEARN key on the unit's remote control.

This completes the necessary settings. Now you can operate the unit with the TV remote control's mute key, volume keys, or power key.



HINT

- The unit exits learning mode automatically if no operations are performed for 5 minutes.
- You can press the  key on the unit's remote control to finish learning mode.

About TV volume

If the learning function is used to teach the unit the TV remote control's "Volume (+)" command, TV volume may increase along with the unit's volume when the TV's remote control is used to increase volume. Should this occur, set TV volume as low as possible using the button on the TV itself, or disable output from the TV's internal speaker(s).

HINT

- If the volume of the speaker(s) built into the TV cannot be adjusted, speaker output can be disabled by connecting a device such as headphones to the headphones (earphones) jack on the TV. Refer to documentation supplied with the TV for details.

Clearing all learned commands

1 Turn off the unit, and then hold down the LEARN key on the unit's remote control for more than 3 seconds.

The unit enters learning mode. When the unit is in learning mode, the indicators flash as shown below.



2 Hold down the key on the unit for more than 3 seconds.



Indicators corresponding to learned commands turn off, and the indicators flash as shown below.

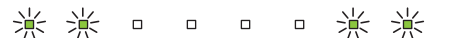

If the clearing is completed, you will hear the bleep sound three times.

3 Press the LEARN key on the unit's remote control.

Using an external subwoofer

The unit has dual built-in subwoofers; however you can connect an external subwoofer when you want to enhance low frequency sound. Connect a subwoofer to the SUBWOOFER OUT jack of the unit. Sound is output from both the built-in subwoofers and external subwoofer.

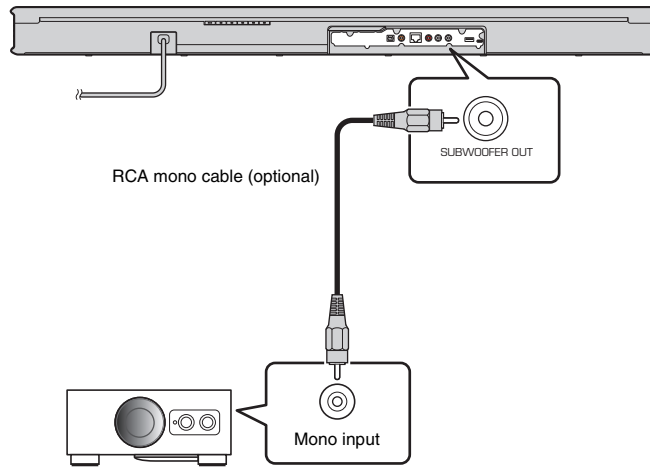

NOTE



- Use an external subwoofer with built-in amplifier.

Enabling/disabling the auto power standby function

Enabling the auto power standby function prevents the unit from remaining on when not in use.

NOTE

- By default, the auto power standby function is enabled on Europe and U.K. models, and disabled on other models.
- When the auto power standby function is enabled, the unit automatically turns off in any of the following situations.
 - No operations for 8 hours
 - No audio input and no operations for 20 minutes when BLUETOOTH or NET is selected as the input source.

- 1 Turn off the unit.
- 2 Hold down the  key and press the  key on the unit.



The auto power standby function is enabled or disabled, and the unit turns on. For several seconds immediately after the unit is turned on, the indicator shows auto power standby function status.

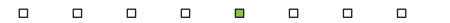

Off (enabled), glows (disabled)

Enabling/disabling the network standby function

Enabling the network standby function allows the unit to be turned on or off using a mobile or *Bluetooth* device as follows.

- When the unit is turned off, it will turn on with the following playback operations.
 - Play back with AirPlay
 - Music files stored on a DLNA-compliant network attached storage (NAS) unit are played
- The unit can also be turned on and off using the MusicCast CONTROLLER app installed on your mobile device.
- When a *Bluetooth* device is connected to this unit while it is off, this unit turns on and the input source switched to BLUETOOTH.

NOTE

- By default, the network standby function is enabled.

- 1 Turn off the unit.
- 2 Hold down the  key and press the  key on the unit.



The network standby function is enabled or disabled, and the unit turns on. For several seconds immediately after the unit is turned on, the indicator shows network standby function status.

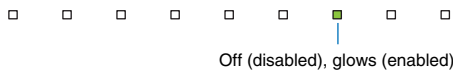

HINT

- The unit consumes more power when it is off with the network standby function enabled than it does when it is off with this function disabled.

Enabling/disabling a wireless (Wi-Fi) connection

Enable or disable a wireless (Wi-Fi) connection.

NOTE

- By default, a wireless (Wi-Fi) connection is enabled.

- 1 Turn off the unit.
- 2 Hold down the **CONNECT** key and press the  key on the unit.



The wireless (Wi-Fi) connection is enabled or disabled, and the unit turns on. For several seconds immediately after the unit is turned on, the indicator shows wireless (Wi-Fi) connection status.

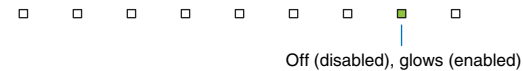

HINT

- When the wireless (Wi-Fi) connection is disabled, connecting the unit to a network with the MusicCast CONTROLLER app also enables the wireless (Wi-Fi) connection.



Enabling/disabling the *Bluetooth* function

Enable or disable the *Bluetooth* function.

NOTE

- By default, the *Bluetooth* function is enabled.

1 Turn off the unit.

2 Hold down the  key and press the  key on the unit.



The *Bluetooth* function is enabled, and the unit turns on. For several seconds immediately after the unit is turned on, the indicator shows *Bluetooth* function status.



Updating the unit's firmware

New firmware that provides additional features or product improvements will be released as needed. Firmware can be updated using the MusicCast CONTROLLER app installed on a mobile device.

Cautions

- Do not operate the unit or disconnect the power cable or network cable during firmware update.
- If the Internet connection speed is slow, or the unit is connected to the wireless network, network update may not be possible depending on the condition of the network connection. Should this occur, try again at a later time.
- For details on update, visit the Yamaha website.

When a new firmware is released, the "Update new firmware now?" message is displayed on the MusicCast CONTROLLER app's screen.

1 Tap "Yes".

The firmware update will begin.

A progress bar indicating update progress will be displayed by the app while firmware is updated. Update progress can also be confirmed using the indicators on the unit.



HINT

- If there are multiple firmware updates, the indicators will start glowing as each firmware update begins.
- If "Later" is selected, tap  (Setup) in the app's room selection screen, and then select "New firmware is available". Follow the on-screen instructions to update the firmware.

If the update is completed successfully, the "Firmware update completed" message will be displayed by the app, and all indicators on the unit will flash.



2 Press the key on the unit.



The firmware update is complete.

NOTE

- If the firmware update fails, the "Failed to update MusicCast device" message will be displayed by the app, and the indicator at far right on the unit will flash blue. Press the  key to turn unit off and then on again, and try updating the firmware again. If the update fails again, check the network connection.

Initializing the unit

Follow the procedure below to initialize the unit.

1 Turn off the unit.

2 Hold down the key and press the key on the unit until all indicators flash.

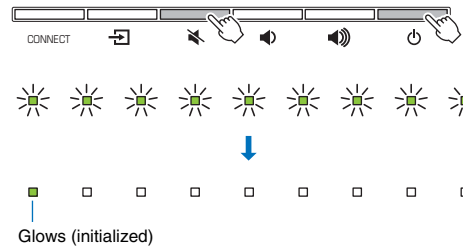

Troubleshooting

Refer to the table below when the unit does not function properly. If the problem you are experiencing is not listed below or if the instructions below do not help, turn off the unit, disconnect the power cable, and contact the nearest authorized Yamaha dealer or service center.

First, check the following:

- ① **The power cables of the unit, TV and playback devices (such as BD/DVD players) are connected to AC wall outlets securely.**
- ② **The unit, TV and playback devices (such as BD/DVD players) are turned on.**
- ③ **The connectors of each cable are securely inserted into jacks on each device.**

Power and system

Problem	Cause	Remedy
The power turns off suddenly.	When the auto power standby function is enabled, the unit automatically turns off in any of the following situations: - No operations have been performed for 8 hours - BLUETOOTH or NET is selected as the input source, but no audio has been input to the unit or no operations have been performed with the unit for more than 20 minutes.	Turn on the unit again. If the auto power standby function is not used, disable the function (p.29).
	The protection circuitry has been activated. (The STATUS indicator flashes.)	After confirming that all connections are made properly, turn on the unit again. If the power still turns off frequently, unplug the power cable from the AC wall outlet and contact the nearest authorized Yamaha dealer or service center.
The power cannot be turned on.	The protection circuitry has been activated three times consecutively. (If you try to turn on the power in this condition, the STATUS indicator will flash.)	To protect the product, the power cannot be turned on. Unplug the power cable from the AC wall outlet and contact the nearest authorized Yamaha dealer or service center.
All indicators go out although the unit is turned on (it may seem that the unit is turned off).	The unit is configured so that indicators do not glow or flash unless the unit is being operated.	Use the DIMMER key to select the desired brightness (p. 15).

Problem	Cause	Remedy
The unit does not function correctly.	The internal microcomputer is frozen, due to an external electric shock (such as lightning or excessive static electricity) or to a drop in the power supply voltage.	Hold down the  key on the unit for more than 10 seconds to turn on the unit. (If the problem persists, unplug the power cable from the AC wall outlet and plug it again.)
The unit turns on by itself.	Another <i>Bluetooth</i> device is being operated nearby.	Terminate <i>Bluetooth</i> connection with the unit (p.16).
The TV's 3D glasses do not work.	The unit is blocking the TV's 3D glasses transmitter.	Confirm the position of the TV's 3D glasses transmitter, and position the unit so that it does not obstruct the transmitter.

Audio

Problem	Cause	Remedy
No sound.	Another input source is selected.	Select an appropriate input source (p. 12).
	The mute function is activated.	Cancel the mute function (p. 13).
	The volume is too low.	Turn up the volume (p. 13).
	The power cable of the unit is not connected properly.	Make sure that the power cable of the unit is connected to an AC wall outlet securely (p. 10).
	Input jacks on a playback device are connected.	Connect the input jack on the unit and the output jack on the playback device.
	Signals that the unit cannot play back are being input.	Change the digital audio output setting on the playback device to PCM, Dolby Digital or DTS Digital Surround.
No sound is coming from the subwoofer.	The volume of the subwoofer is too low.	Turn up the volume of the subwoofer (p. 13).
	The playback source does not contain low-frequency signals.	Play back a sound source containing low-frequency signals, and confirm that the sound is output from the subwoofer.
The volume decreases when the unit is turned on.	The automatic volume adjustment function is activated. To prevent excessive loudness, the unit automatically controls its volume within a certain level when the unit is turned on.	Turn up the volume as required (p. 13).

Problem	Cause	Remedy
No surround effect.	Stereo playback is selected.	Select surround playback (p. 12).
	The volume is too low.	Turn up the volume (p. 13).
	The TV or playback device is set to output 2 channel audio (such as PCM) only.	Change the digital audio output setting on the TV or playback device to BitStream.
	Sound is also heard from the TV built-in speakers.	Set the TV volume to minimum (p. 10).
	The listening position is too close to the unit.	The listening position should be at some distance from the unit.
Noise is heard.	The unit is too close to another digital or high-frequency device.	Move those devices away from the unit.

Remote control

Problem	Cause	Remedy
The unit cannot be operated using the remote control.	The unit is out of the operating range.	Use the remote control within the operating range (p.3).
	The batteries are weak.	Replace with new batteries (p.3).
	The remote control sensor of the unit is exposed to direct sunlight or strong lighting.	Adjust the lighting angle, or reposition the unit.
The TV cannot be operated when the TV's remote control is pointed toward the unit's remote control sensor.	The unit and TV are too far apart (or too close), preventing proper operation of the unit's TV remote repeater function.	Position the unit so that it is more than 5 cm (2 in) away from the TV (p.8).
	There are obstacles between the unit and the TV (cables, etc.), preventing proper operation of the unit's TV remote repeater function.	Remove obstacles between the unit and the TV.
	The TV's remote control does not use infrared signals.	The unit's TV remote repeater function cannot be used.
	Signals transmitted from the TV's remote control and the unit's TV remote repeater interfere with each other, making it difficult for the TV to receive signals.	Reposition the unit so that it does not obstruct the remote control sensor on the TV, and point the TV's remote control at the remote control sensor on the TV to control the TV.
The unit does not learn TV remote control commands.	The TV's remote control key was not held down long enough.	Hold down the key for at least 1 second and release it for at least 1 second. Perform this operation twice. If the unit fails to learn functions, perform this operation three times (p.27).
	The TV's remote control does not use infrared signals. (Some remote controls may not function even if it uses infrared signals.)	The TV's remote control cannot be used to teach the unit TV remote control commands. Use the unit's remote control to operate the unit.
	The TV's remote control is not pointed at the unit's remote control sensor.	Point the TV's remote control at the unit's remote control sensor (p.27).

Problem	Cause	Remedy
The unit does not learn TV remote control commands.	The batteries of the TV's remote control are weak.	Replace with new batteries.
	The remote control sensor of the unit is exposed to direct sunlight or strong lighting.	Adjust the lighting angle, or reposition the unit.
	The transmission of the remote control signal was disturbed by the TV screen light.	Turn off the TV (p.26).
	The remote control for the cable or satellite set-top box is used for learning.	Use the TV's remote control for learning, then use the remote control for the set-top box to operate the unit.
Sound comes from the TV when the unit's volume is increased using the TV's remote control (when the unit has been taught TV remote control commands).	Audio output is enabled on the TV.	Change the TV setting to disable the TV speaker output. If a setting to disable the speaker output is not available on your TV, try the following methods. - Connect headphones to the headphones jack on the TV. - Set the TV volume to minimum.
	When the power key on the TV's remote control is pressed, power status for the unit and the TV is reversed (e.g., when the unit is turned on, the TV turns off) (when the unit has been taught TV remote control commands).	The power of the TV was on when you performed the learning operation.

Bluetooth

Receiving

Problem	Cause	Remedy
Unable to connect the unit to a Bluetooth device.	The <i>Bluetooth</i> function is disabled.	Enable the function (p.31).
	<i>Bluetooth</i> is not selected as the input source.	Select <i>Bluetooth</i> as the input source (p.16).
	Another <i>Bluetooth</i> device is connected.	Terminate the current <i>Bluetooth</i> connection, and connect to the device from which audio should be received (p.16).
	A <i>Bluetooth</i> adaptor, etc. that you want to connect to the unit has a password other than "0000".	Use a <i>Bluetooth</i> adaptor, etc. whose password is "0000" (p.16).
	The device does not support A2DP.	Connect to a <i>Bluetooth</i> audio device that supports A2DP.
	The unit and device are too far apart.	Position the <i>Bluetooth</i> device so that it is less than 10 m (33 ft) from this unit and connect the device to this unit.
	There is a device (microwave oven, wireless LAN, etc.) outputs signals in the 2.4 GHz frequency band nearby.	Move this unit away from the device that is emitting radio frequency signals.
No sound is heard or the sound is intermittent via the unit.	The device is not set to send <i>Bluetooth</i> audio signals to the unit.	Check that the <i>Bluetooth</i> function of the device is set properly.
	Playback on the device has not been performed.	Perform playback on the device.
	The device's volume is set to minimum.	Turn up the volume level on the device.
	The unit and device are too far apart.	Move the <i>Bluetooth</i> device so that it is less than 10 m (33 ft) from this unit.
	There is a device (microwave oven, wireless LAN, etc.) outputs signals in the 2.4 GHz frequency band nearby.	Move this unit away from the device that is emitting radio frequency signal.
	The <i>Bluetooth</i> connection of the unit with the device is disconnected.	Perform <i>Bluetooth</i> connection operations again (p.16).

Transmitting

Problem	Cause	Remedy
Cannot make the unit connected to the Bluetooth device.	The <i>Bluetooth</i> function is disabled.	Enable the function (p.31).
	Another <i>Bluetooth</i> device is connected.	Terminate the current <i>Bluetooth</i> connection, and connect to the device to which audio should be transmitted (p.17).
	The device does not support A2DP.	Connect to a <i>Bluetooth</i> audio device that supports A2DP.
	The unit and device are too far apart.	Position the <i>Bluetooth</i> device so that it is less than 10 m (33 ft) from this unit and connect the device to this unit.
	There is a device (microwave oven, wireless LAN, etc.) outputs signals in the 2.4 GHz frequency band nearby.	Move this unit away from the device that is emitting radio frequency signals.
	No sound is heard or the sound is intermittent via the Bluetooth device.	The device is not set to receive <i>Bluetooth</i> audio signals from the unit.
The device's volume is set to minimum.		Turn up the volume level on the device.
The sound to be transmitted is not playing.		Use the MusicCast CONTROLLER app to play sound from devices other than <i>Bluetooth</i> devices (p.17).
The unit and device are too far apart.		Move the <i>Bluetooth</i> device so that it is less than 10 m (33 ft) from this unit.
There is a device (microwave oven, wireless LAN, etc.) outputs signals in the 2.4 GHz frequency band nearby.		Move this unit away from the device that is emitting radio frequency signals.
The <i>Bluetooth</i> connection of the unit with the device is disconnected.		Perform <i>Bluetooth</i> connection operations again (p.17).
Attempted to establish a connection during playback with AirPlay.		Playback with AirPlay cannot be transmitted. Terminate AirPlay playback and try again to establish a connection (p.24).

Network

Problem	Cause	Remedy
Playback stops unexpectedly and files cannot be played continuously.	The folder contains some files that cannot be played via the unit.	Delete or move files (including video or hidden files) that cannot be played via the unit from the folder on your PC (media server).
The unit does not detect the PC (media server).	The media sharing setting is not correct.	Configure the sharing setting and select the unit as a device to which music contents are shared (p.22).
	Some security software installed on your PC (media server) is blocking the access of the unit to your PC (media server).	Check the settings of security software installed on your PC (media server).
	The PC (media server) is not on the same network as the unit and mobile device.	Check the PC's (media server's) network settings, and connect the PC (media server) to the same network to which the unit and mobile device are connected.
The files in the PC (media server) cannot be viewed or played back.	The files are not supported by the unit or the PC (media server).	Use the file format supported by both the unit and the PC (media server) (p.22).
The Internet radio cannot be played.	The selected Internet radio station is currently not available.	There may be a network problem at the radio station, or the service may have been stopped. Try the station later or select another station.
	The selected Internet radio station is currently broadcasting silence.	Some Internet radio stations broadcast silence at certain of times of the day. Try the station later or select another station.
	Access to the network is restricted by the firewall settings of your network devices (such as the router).	Check the firewall settings of your network devices. The Internet radio can be played only when it passes through the port designated by each radio station. The port number varies depending on the radio station.
Firmware update fails.	It may not be possible depending on the condition of the network.	Try again at a later time (p.31).
The iPod does not recognize the unit when using AirPlay.	The unit and iPod/mobile device are connected to different SSIDs on the same access point.	Check the network connections for the unit and your mobile device, and connect them to the same SSID.

Problem	Cause	Remedy
The unit cannot connect to the Internet via a wireless router (access point).	The wireless router (access point) is turned off.	Turn on the wireless router (access point).
	The unit and the wireless router (access point) are too far apart.	Place the unit and the wireless router (access point) closer to each other.
	There is an obstacle between the unit and the wireless router (access point).	Move the unit and the wireless router (access point) in a location where there are no obstacles between them.
Wireless network is not found.	There is a device (microwave oven, wireless LAN, etc.) outputs signals in the 2.4 GHz frequency band nearby.	Move this unit away from the device that is emitting radio frequency signals.
	Access to the network is restricted by the firewall settings of the wireless router (access point).	Check the firewall setting of the wireless router (access point).

Specifications

Item		Specifications
Amplifier Section	Maximum Rated Output Power	Front L/R 30 W x 2 ch
		Subwoofer 60 W
Front L/R Section	Type	Acoustic suspension type
	Driver	5.5 cm (2-1/8") cone non-magnetic shielding type x 2
	Frequency Response	150Hz to 22kHz
	Impedance	6Ω
Tweeter Section	Type	—
	Driver	19 mm (3/4") balanced dome magnetic shielding type x 2
	Frequency Response	4kHz to 23kHz
	Impedance	4Ω
Subwoofer Section	Type	Bass reflex type
	Driver	7.5 cm (3") cone non-magnetic shielding type x 2
	Frequency Response	55Hz to 150Hz
	Impedance	3Ω
Decoder	Supported audio signal	PCM (2ch) Dolby Digital (up to 5.1ch) DTS Digital Surround (up to 5.1ch)
Input Jacks	Digital (Optical)	1 (TV)
	Digital (Coaxial)	1 (BD/DVD)
	Analog (RCA/stereo)	1 pair (ANALOG)
Output Jack	Analog (RCA/monaural)	1 (SUBWOOFER OUT)
Other Jacks	Service jack	1 (SERVICE ONLY)
	LAN	1 (NETWORK)
Network	Ethernet standard: 100BASE-T/10BASE-T	
	Supported codecs	WAV (PCM format only) /AIFF/FLAC: up to 192 kHz ALAC: up to 96 kHz MP3/WMA/MPEG-4 AAC: up to 48 kHz
	Compatible with DLNA ver. 1.5 AirPlay supported Internet Radio	

Item		Specifications
Wireless LAN (Wi-Fi)	Wireless LAN Standards	IEEE802.11b/g/n
	Radio Frequency Band	2.4 GHz
Bluetooth	Bluetooth version	Ver. 2.1 +EDR
	Radio Frequency Band	2.4 GHz
	Supported protocols	Receiving: A2DP, AVRCP Transmitting: A2DP
	Supported codecs	Receiving: SBC, MPEG-4 AAC Transmitting: SBC
	Wireless output	Bluetooth Class 2
	Range (line-of-sight)	Approx. 10 m (33 ft)
	Supported content protection method	SCMS-T (receiving)
General	Power Supply	U.S.A. and Canada models: AC 120 V, 60Hz Brazil and Taiwan models: AC 110 - 120 V, 50/60Hz China model: AC 220V, 50Hz Other models: AC 220 - 240 V, 50/60Hz
	Power Consumption	22 W
	Standby Power Consumption	Network Standby Off: 0.3 W Network Standby On (Wi-Fi + Bluetooth): 1.9 W Network Standby On (Wired/Wi-Fi/Bluetooth): 1.8/1.9/1.7 W
	Dimensions (W x H x D)	950 x 72 x 131 mm (37-3/8" x 2-7/8" x 5-1/8") (installing the unit in front of a TV, etc.) 950 x 131 x 80 mm (37-3/8" x 5-1/8" x 3-1/8") (mounting the unit on a wall, with spacer)
	Weight	4.9 kg (10.8 lbs)

* The contents of this manual apply to the latest specifications as of the publishing date.
To obtain the latest manual, access the Yamaha website then download the manual file.



This system is equipped with Yamaha's AIR SURROUND XTREME virtual sound technology that achieves superior positional, high-grade 7.1 channel surround sound using the sound bar.



MusicCast is a trademark or registered trademark of Yamaha Corporation.



Manufactured under license from Dolby Laboratories. Dolby, Dolby Audio, Pro Logic, and the double-D symbol are trademarks of Dolby Laboratories.



For DTS patents, see <http://patents.dts.com>. Manufactured under license from DTS Licensing Limited. DTS, the Symbol, & DTS and the Symbol together are registered trademarks, and DTS Digital Surround is a trademark of DTS, Inc. © DTS, Inc. All Rights Reserved.



DLNA™ and DLNA CERTIFIED™ are trademarks or registered trademarks of Digital Living Network Alliance. All rights reserved. Unauthorized use is strictly prohibited.



The Wi-Fi CERTIFIED Logo is a certification mark of Wi-Fi Alliance. The Wi-Fi Protected Setup Identifier Mark is a certification mark of Wi-Fi Alliance.

Wi-Fi, Wi-Fi Alliance, Wi-Fi CERTIFIED, Wi-Fi Protected Setup, WPA and WPA2 are trademark or registered trademark of Wi-Fi Alliance.



The *Bluetooth*® word mark and logos are registered trademarks owned by *Bluetooth* SIG, Inc. and any use of such marks by Yamaha Corporation is under license.

Bluetooth

Bluetooth is a technology for wireless communication employing the 2.4 GHz frequency band, which can be used without a license.

Handling Bluetooth communications

- The 2.4 GHz band used by *Bluetooth* compatible devices is a radio band shared by many types of equipment. While *Bluetooth* compatible devices use a technology minimizing the influence of other components using the same radio band, such influence may reduce the speed or distance of communications and in some cases interrupt communications.
- The speed of signal transfer and the distance at which communications is possible differs according to the distance between the communicating devices, the presence of obstacles, radio wave conditions and type of equipment.
- Yamaha does not guarantee all wireless connections between this unit and devices compatible with *Bluetooth* function.



"Made for iPod," "Made for iPhone," and "Made for iPad" mean that an electronic accessory has been designed to connect specifically to iPod, iPhone, or iPad, respectively, and has been certified by the developer to meet Apple performance standards. Apple is not responsible for the operation of this device or its compliance with safety and regulatory standards. Please note that the use of this accessory with iPod, iPhone, or iPad may affect wireless performance. Supports iOS 7 or later for setup using Wireless Accessory Configuration.

iTunes, AirPlay, iPad, iPhone, iPod, iPod nano, iPod touch, and Safari are trademarks of Apple Inc., registered in the U.S. and other countries.

AppStore

App Store is a service mark of Apple Inc.

Android / Google Play

Android and Google Play are trademarks of Google Inc.

Blu-ray

"Blu-ray Disc™", "Blu-ray™", and the logos are trademarks of the Blue-ray Disc Association.

Explanations regarding GPL

This product utilizes GPL/LGPL open-source software in some sections. You have the right to obtain, duplicate, modify, and redistribute this open-source code only. For information on GPL/LGPL open source software, how to obtain it, and the GPL/LGPL license, refer to the Yamaha Corporation website (<http://download.yamaha.com/sourcecodes/musiccast/>).

Bluetooth protocol stack (Blue SDK)

Copyright 1999-2014 OpenSynergy GmbH

All rights reserved. All unpublished rights reserved.

Windows

Windows is a registered trademark of Microsoft Corporation in the United States and other countries.

Internet Explorer, Windows Media Audio and Windows Media Player are either registered trademarks or trademarks of Microsoft Corporation in the United States and/or other countries.



Yamaha Global Site
<http://www.yamaha.com/>

Yamaha Downloads
<http://download.yamaha.com/>

Manual Development Group
© 2016 Yamaha Corporation

Published 06/2016 KS-A0

YH928A0/EN