

**SMART
OUTDOOR
CAMERA**

Manual



SINJI

INDEX

English	4
Nederlands	14
Français	24
Deutsch	34
Español	44
Italiano	54
Portuguese	64



SINJI

1. PACKAGE CONTENTS

Please check if the camera is intact and all accessories are included.

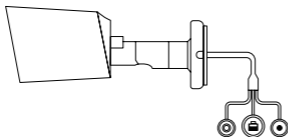

Camera x1



User manual x1

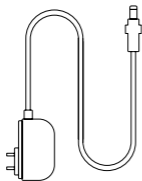

Power adapter x1



Sealed hose kit x1



Antenna x1



Line buckle x4

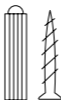

Screw x4



Waterproof tape x2

2. APPEARANCE

Please adjust the installation angle and tighten the three screws as shown in the image. To readjust the angle, please loosen the screws before adjusting them.

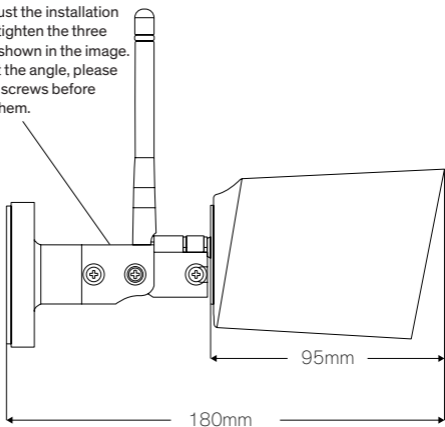

Note:

Please note that adjusting the angle multiple times may cause wear of the screws (the latch will wear out the joints).

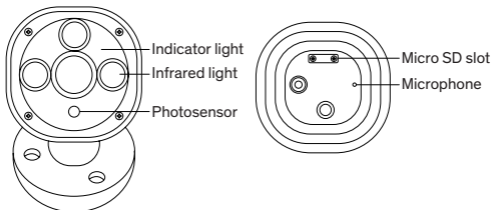

3. INSTALLATION INSTRUCTIONS

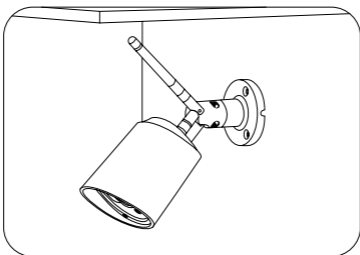

Wall mounted

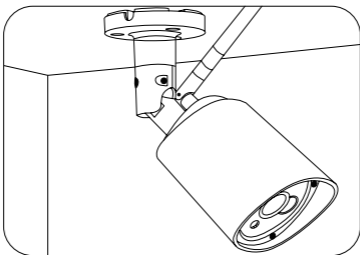

Ceiling mounted

Note:

1. Please pay attention to the waterproofing measures for outdoor installation. See following images for a detailed instruction.
2. Please pay attention to outdoor lightning protection.

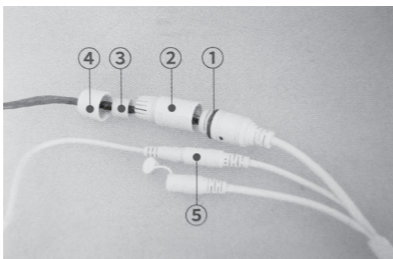

- Fit the red O ring in the net port seat ①.
- Tighten the ①, ②, ③, and ④ parts.
- Connect the power cord to the ⑤ power port.

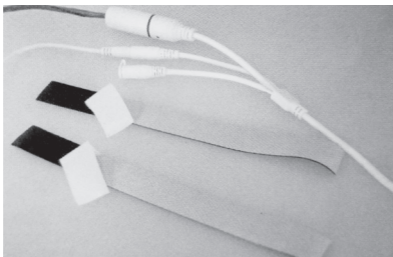

- Remove the paper at the back of the waterproof tape.



- When applying the waterproof tape, keep tension on the tape by stretching it during assembly. This way the waterproof tape works best.

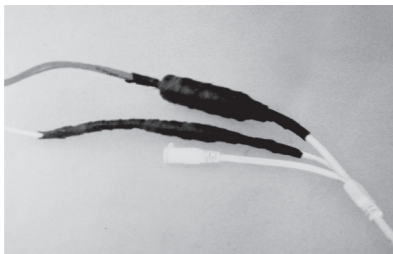

- The result after wrapping waterproof tape.

4. INSTRUCTIONS FOR USE

1. **Connecting the Smart Outdoor Camera**

Connect the Smart Outdoor Camera to a power source using the included power adapter.

2. **App installation**

Go to the App Store on your mobile device to download the app "Doby".



Sign up with your email address and choose a password. If you already have an account, please tap "Sign in".



3. Add device

Open “Doby” [Home], tap “+” to search devices.
Choose “Camera (Outdoor Version)”.

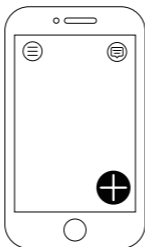

Wired connection

Please check if the camera and app are connected to the same network and the net led indicator is lit. Select the device CID, and tap “Next”.

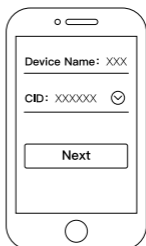
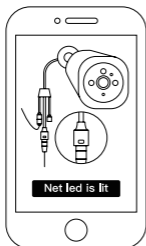

WiFi connection

- Please make sure the WiFi indicator on the Outdoor Camera is flashing blue. If not, please press and hold the WiFi button for a few seconds until the WiFi indicator blinks.

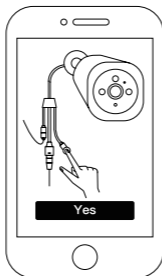

- Via [Settings]>[Wi-Fi] on your mobile device, connect to DOG-00***, enter the code "11111111". Return to the Doby app and tap "Next".



- Choose a device name, for example “Garden”. Choose a network and enter the password. Tap “Next”. The Smart Outdoor Camera will start connecting to the network and the WiFi indicator will flash red. It may take a few minutes until the connection is established. When the WiFi indicator turns blue, the camera has connected successfully. Tap “Done” on your mobile device. You are now ready to use the Smart Outdoor Camera.

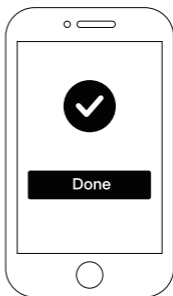
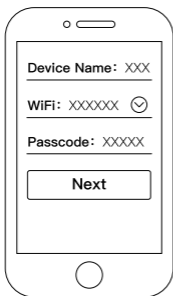

5. PROBLEMS AND SOLUTIONS

1. How far is the monitoring range?

In daylight the camera has a visual distance of 50 meters. With infrared night vision the visual distance is about 15 meters.

2. The Smart Outdoor Camera gives the status “offline” after connecting.

- Ensure the WiFi password for your home network is entered correctly in the settings menu of the “Doby” application.
- Ensure your mobile device is connected to the same WiFi network as your camera to make the initial connection.

3. The SD Card cannot be detected.

Please ensure the SD card is formatted as FAT32.

6. TECHNICAL SPECIFICATIONS

Lens:	Wide-angle lens
Angle:	Diag. 105°, horiz. 90°, vert. 60°
Video compression:	H.264
Resolution:	1280 × 960 @15fps
Audio:	Single microphone
WiFi Protocol Support:	IEEE802.11 b/g/n (2.4GHz)
Encryption:	WPA2 / WPA / WEP / OPEN
Network:	Wi-Fi/Cable RJ45
Power:	12V/1A
Operating Conditions:	Temperature -30~60°C, Humidity <90%
Size:	67 × 105 × 145mm

1. INHOUD VAN DE VERPAKKING

Controleer of de camera intact is en alle accessoires in de doos zitten.

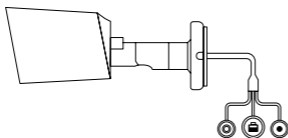

Camera x1



Handleiding x1

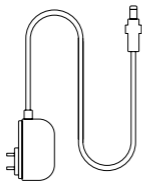

Voedingsadapter x1



Kabel behuizing x1



Antenne x1



Lijngesp x4



Schroef x4



Waterdichte tape x2

2. UITERLIJK

Pas de installatiehoek aan en draai de drie schroeven vast zoals wordt weergegeven in de afbeelding. Om de hoek opnieuw aan te passen, draait u de schroeven los voordat u ze afstelt.

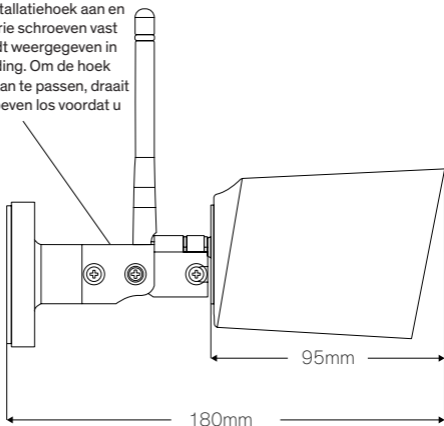

Let op:

Houd er rekening mee dat het meerdere keren aanpassen van de hoek kan leiden tot slijtage van de schroeven (de vergrendeling zal de naden verslijten).

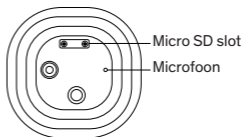
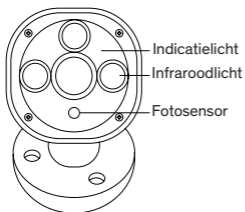

3. INSTRUCTIES VOOR INSTALLATIE

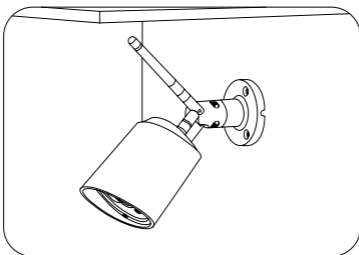

Muurmontage

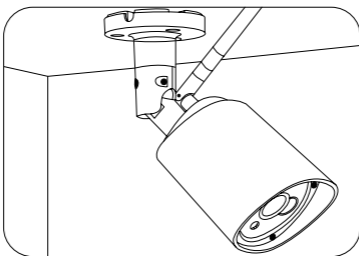

Plafondmontage

Let op:

1. Let op water-dichtende maatregelen voor installatie buitenshuis. Zie de volgende afbeeldingen voor een gedetailleerde instructie.
2. Let op bliksembeveiliging.

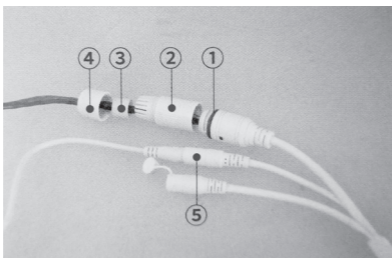

- Plaats de rode O-ring in de netpoortzitting ①.
- Draai de onderdelen ①, ②, ③, en ④ vast.
- Sluit het netsnoer aan op de voedingspoort ⑤.

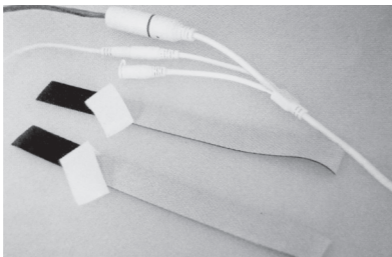

- Verwijder het papier aan de achterkant van de waterdichte tape.



- Houd bij het aanbrengen van de waterdichte tape spanning op de tape door deze tijdens de montage uit te rekken. Op deze manier werkt de waterdichte tape het best.

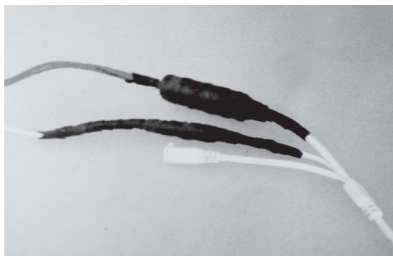

- Het resultaat na het wikkelen van waterdichte tape.

4. INSTRUCTIES VOOR GEBRUIK

1. **Verbind de Smart Outdoor Camera**

Verbind de Smart Outdoor Camera aan een voedingsbron door middel van de meegeleverde kabel.

2. **Installatie van de app**

Ga naar de App Store op uw mobiele apparaat om de “Doby” app te downloaden.



Registreer met uw e-mail en kies een wachtwoord. Als u al een account heeft, tik op “Sign in”.



3. Voeg de Smart Outdoor Camera toe aan uw mobiele apparaat

Open "Doby" [Home], tik "+" om naar apparaten te zoeken. Kies "Camera (Outdoor Version)".

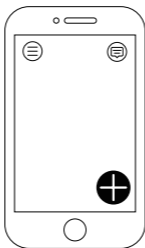

Bedrade verbinding

Controleer of de camera en de app op hetzelfde netwerk zijn aangesloten en of de led-indicator voor het netwerk brandt. Selecteer de apparaat-CID en tik op "Next".

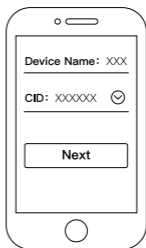
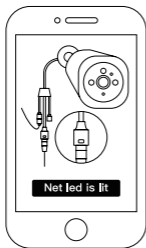

Draadloze (WiFi) verbinding

- Zorg ervoor dat de WiFi-indicator op de Smart Outdoor Camera blauw knippert. Indien dit niet het geval is, druk op de WiFi-knop en houd die enkele seconden ingedrukt tot de WiFi-indicator knippert.

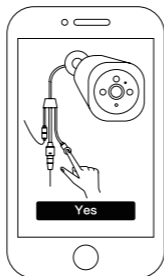

- Via [Settings]>[Wi-Fi] op uw mobiele apparaat verbindt u met DOG-00***, met het wachtwoord "11111111". Ga terug naar "Doby", tik "Next".



- Kies een naam voor het apparaat, bijvoorbeeld "Tuin". Kies een netwerk en geef het wachtwoord in. Tik "Next". De Smart Outdoor Camera zal met het netwerk verbinden, de WiFi-indicator zal rood knipperen. Dit kan enkele minuten duren. Als de WiFi-indicator blauw wordt, is de camera succesvol verbonden. Tik "Done" op uw mobiele apparaat. U kunt de Smart Outdoor Camera nu gebruiken.

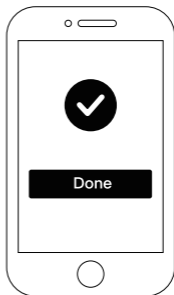
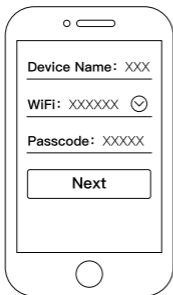

5. HULP BIJ PROBLEMEN

1. Hoe ver is het bewakingsbereik?

Bij daglicht heeft de camera een visuele afstand van 50 meter. Met infrarood nachtzicht is de visuele afstand ongeveer 15 meter.

2. De Smart Outdoor Camera geeft de status “offline” na verbinden.

- Zorg ervoor dat het WiFi wachtwoord voor uw thuisnetwerk goed is ingetoetst in het instellingenmenu van de “Doby” app.
- Zorg ervoor bij het verbinden van de camera dat uw mobiele apparaat is verbonden met hetzelfde WiFi netwerk als uw camera.

3. De SD-kaart kan niet gedetecteerd worden.

Zorg ervoor dat de SD-kaart is geformatteerd als FAT32.

6. TECHNISCHE SPECIFICATIES

Lens:	Groothoeklens
Hoek:	Diag. 105°, horiz. 90°, vert. 60°
Videocompressie:	H.264
Resolutie:	1280 × 960 @15fps
Audio:	Enkele microfoon
WiFi-protocol:	IEEE802.11 b/g/n (2.4GHz)
Encryptie:	WPA2 / WPA / WEP / OPEN
Netwerk:	Wi-Fi/kabel RJ45
Vermogen:	12V/1A
Werkomstandigheden:	Temperatuur -30~60°C, Vochtigheid <90%
Afmetingen:	67 × 105 × 145mm

1. CONTENU DE L'EMBALLAGE

Veillez vérifier que la caméra est bien intacte et que tous les accessoires sont présents.

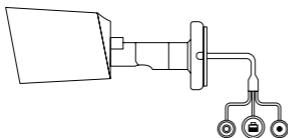

Camera x1



Manuel d'utilisation x1

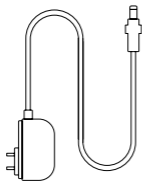

Adaptateur électrique x1



Set pour etancher x1



Antenne x1



Fermoir de corde x4

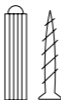

Vis x4



Ruban adhesif
impermeable x2

2. APPARENCE

Veillez ajuster l'angle d'installation et serrer les trois vis comme montré sur l'image. Afin de réajuster l'angle, veuillez desserrer les vis avant de les ajuster.

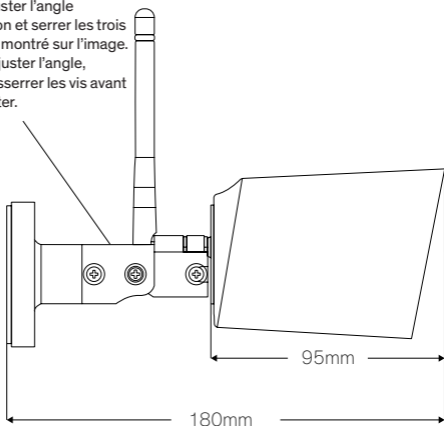

Note :

Veillez noter que le fait d'ajuster l'angle à plusieurs reprises peut user les vis (le verrouillage va user les jonctions).

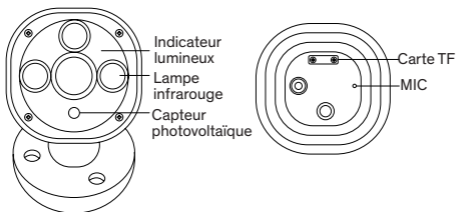

3. INSTRUCTIONS D'INSTALLATION

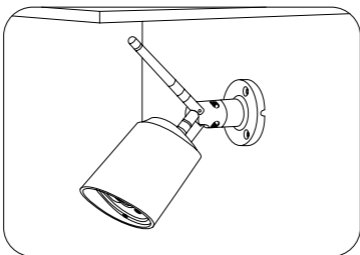

Montage mural

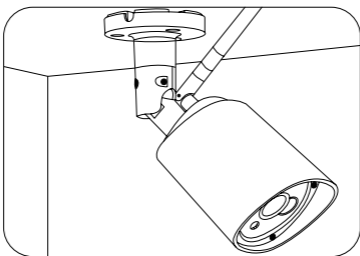

Montage plafond

Note :

1. Veuillez être attentif aux mesures d'étanchéité nécessaires pour des installations extérieures. Voir les images ci-dessous pour des instructions détaillées.
2. Veuillez être attentif à la protection parafoudre.

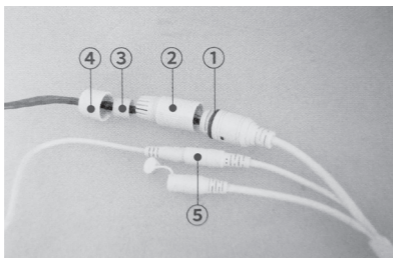

- Placez l'O-ring rouge au fond du port réseau ①.
- Serrez les éléments ①, ②, ③, et ④.
- Branchez le câble secteur au port d'alimentation ⑤.

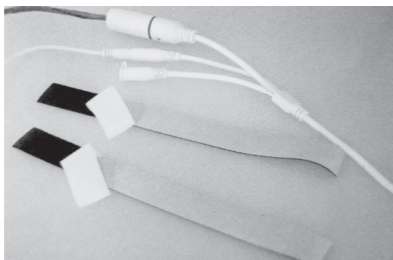

- Retirez le papier au verso de l'adhésif imperméable.



- Lorsque vous appliquez le ruban, maintenez une tension sur l'adhésif en l'étirant durant l'assemblage. C'est de cette façon que l'adhésif imperméable fonctionne le mieux.

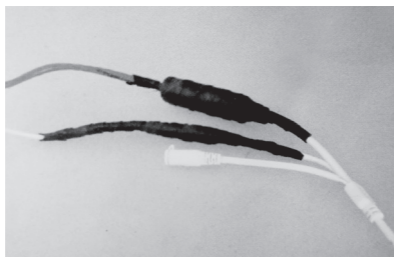

- Le résultat après enveloppement avec le ruban imperméable.

4. INSTRUCTIONS D'UTILISATION

1. Brancher la Smart Outdoor Camera

Branchez la Smart Outdoor Camera à une source d'alimentation en utilisant l'adaptateur électrique inclus.

2. Installation de l'appli

Allez sur l'App Store sur votre appareil mobile afin de télécharger l'appli « Doby ».



Inscrivez-vous avec votre adresse email et choisissez un mot de passe. Si vous avez déjà un compte, veuillez cliquer sur «Sign in ».

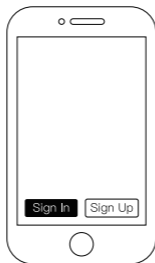

3. Ajouter un appareil

Ouvrez « Doby » [Home], cliquez sur « + » afin de chercher des appareils. Choisissez « Camera (Outdoor Version) ».

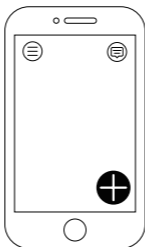

Connexion filaire

Veillez vérifier que la caméra et l'appli soient bien connectées au même réseau et que le voyant réseau est allumé. Sélectionnez l'appareil CID, et cliquez sur « Next ».

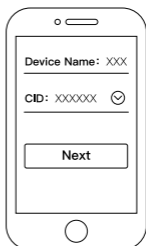
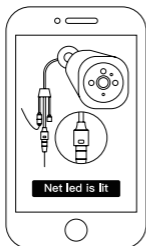

Connexion WiFi

- Veuillez vous assurer que l'indicateur wifi de la Smart Outdoor Camera clignote en bleu. Si ce n'est pas le cas, maintenez le bouton wifi appuyé pendant quelques secondes.

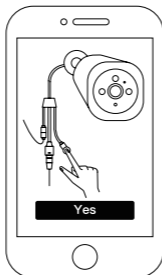

- Via [Settings]>[Wi-Fi] sur votre appareil mobile, connectez-vous à DOG-00***, et entrez le code « 11111111 ». Retournez sur l'appli Doby et cliquez sur « Next ».



- Choisissez un nom pour l'appareil, par exemple « jardin ». Sélectionnez un réseau et entrez le mot de passe. Cliquez sur « Next ». La Smart Outdoor Camera va se connecter au réseau et l'indicateur wifi va devenir rouge. Cela peut prendre quelques minutes avant que la connexion ne soit établie. Lorsque l'indicateur wifi devient bleu, la caméra s'est connectée avec succès. Cliquez sur « Done » sur votre appareil mobile. Vous êtes maintenant prêt à utiliser la Smart Outdoor Camera.

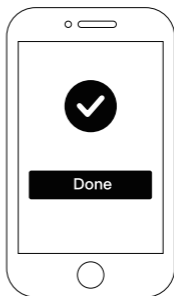
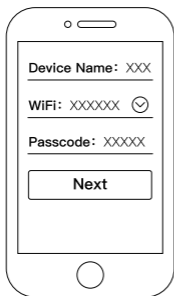

5. PROBLÈMES ET SOLUTIONS

1. Quelle est la portée de la surveillance ?

En journée, la caméra a une portée visuelle de 50 mètres. La vision nocturne infrarouge a une portée d'environ 15 mètres.

2. La Smart Outdoor Camera affiche « offline » après connexion.

- Assurez-vous que le mot de passe wifi de votre réseau est correctement entré dans le menu des paramètres de l'application « Doby ».
- Assurez-vous que votre appareil mobile soit bien connecté au même réseau wifi que votre caméra afin d'effectuer la connexion initiale.

3. La carte SD n'est pas détectée.

Assurez-vous que la carte SD est bien formatée en FAT32.

6. CARACTÉRISTIQUES TECHNIQUES

Lentille :	Lentille angle large
Angle :	Diag. 105, horiz. 90, vert. 60
Compression vidéo :	H.264
Résolution :	1280 × 960@15fps
Audio :	Microphone unique
protocole WiFi :	IEEE802.11 b/g/n/ (2.4GHz)
Cryptage :	WPA2/WPA/WEP/OPEN
Réseau :	Wi-Fi/Câble RJ45
Alimentation :	12V/1A
Conditions d'utilisation :	Température -30 à 60°C, Humidité <90%
Taille :	67 × 105 × 145mm

1. PACKUNGSINHALT

Bitte überprüfen Sie, ob die Kamera intakt ist und alle Zubehörteile enthalten sind.

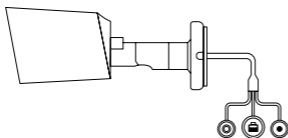

Kamera x1



Bedienungsanleitung x1

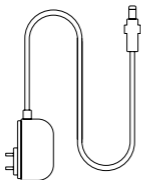

Netzteil x1



Versiegeltes Schlauchset x1



Antenne x1



Kabelbinder x4



Schraube x4



Wasserfestes
Klebeband x2

2. ÄUSSERES

Bitte justieren Sie den Installationswinkel und ziehen Sie die drei Schrauben wie in der Abbildung gezeigt an. Um den Winkel neu einzustellen, lösen Sie bitte die Schrauben, bevor Sie sie einstellen.

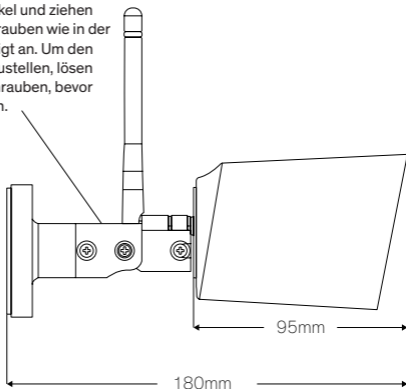

Hinweis:

Bitte beachten Sie, dass das mehrfache Einstellen des Winkels zu einem Verschleiß der Schrauben führen kann (der Riegel nutzt die Verbindungen ab).

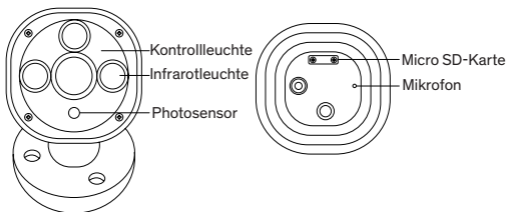

3. INSTALLATIONSANWEISUNGEN

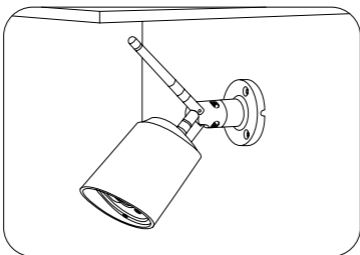

Wandmontage

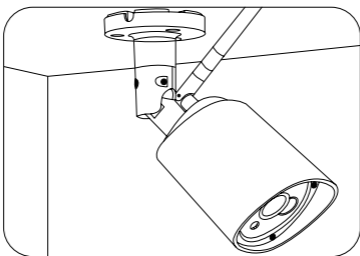

Deckenmontage

Hinweis:

1. Bitte beachten Sie die Abdichtungsmaßnahmen für den Außenbereich. Siehe folgende Bilder für eine detaillierte Anleitung.
2. Bitte achten Sie auf Blitzschutz für den Außenbereich.

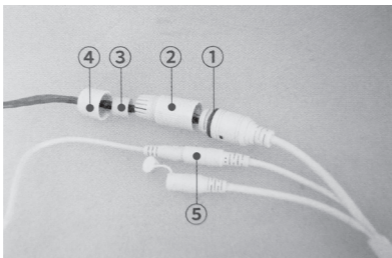

- Setzen Sie den roten O-Ring in den Netzanschluss ①.
- Ziehen Sie die Teile ①, ②, ③, und ④ fest.
- Verbinden Sie das Netzkabel mit dem Stromanschluss ⑤.

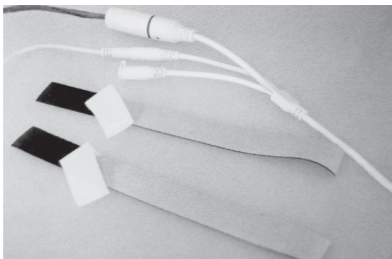

- Entfernen Sie das Papier auf der Rückseite des wasserdichten Klebebands.



- Halten Sie beim Anbringen des wasserdichten Bands das Band gespannt, indem Sie es während der Montage dehnen. Auf diese Weise funktioniert das wasserdichte Klebeband am besten.

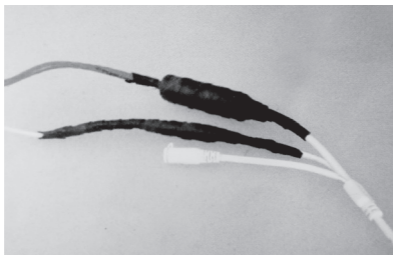

- Das Ergebnis nach dem Umwickeln mit wasserfestem Klebeband.

4. ANWENDUNGSHINWEISE

1. Anschließen der Smart Outdoor Camera

Verbinden Sie die Smart Outdoor Camera über das mitgelieferte Netzteil mit einer Stromquelle.

2. Installation der App

Rufen Sie den App Store auf Ihrem Mobilgerät auf, um die "Doby" App herunterzuladen.



Melden Sie sich mit Ihrer E-Mail-Adresse an und wählen Sie ein Passwort. Wenn Sie bereits einen Account haben, tippen Sie bitte auf "Sign in".



3. Gerät hinzufügen

Öffnen Sie "Doby" [Home], tippen Sie auf "+", um Geräte zu suchen. Wählen Sie "Camera (Outdoor Version)".

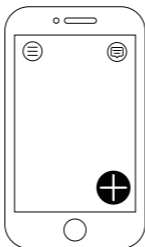

Kabelverbindung

Bitte überprüfen Sie, ob Kamera und App mit dem gleichen Netzwerk verbunden sind und die Netz-LED leuchtet. Wählen Sie die Geräte-CID und tippen Sie auf "Next".

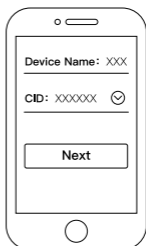
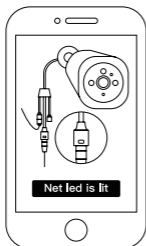

WLAN-Verbindung

- Bitte stellen Sie sicher, dass die WiFi - Anzeige auf der Smart Outdoor Camera blau blinkt. Wenn nicht, drücken und halten Sie die WiFi-Taste für einige Sekunden, bis die WiFi-Anzeige blinkt.

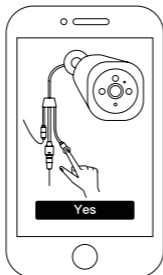

- Über [Settings]> [Wi-Fi] auf Ihrem Mobilgerät stellen Sie eine Verbindung DOG-00*** her, geben Sie den Code ein "11111111" ein. Kehren Sie zur Doby App zurück und tippen Sie auf "Next".



- Wählen Sie einen Gerätenamen, zum Beispiel "Garten". Wählen Sie ein Netzwerk und geben Sie das Kennwort ein. Tippen Sie auf "Next". Die Smart Outdoor Camera beginnt, sich mit dem Netzwerk zu verbinden und die WLAN-Anzeige blinkt rot. Es kann einige Minuten dauern, bis die Verbindung hergestellt ist. Wenn die WLAN-Anzeige blau leuchtet, hat die Kamera erfolgreich eine Verbindung hergestellt. Tippen Sie auf Ihrem Mobiltelefon auf "Done". Sie können die Smart Outdoor Camera jetzt verwenden.

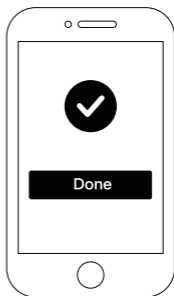
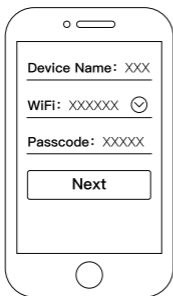

5. PROBLEME UND LÖSUNGEN

1. Wie weit ist der Überwachungsbereich?

Bei Tageslicht hat die Kamera eine Sichtweite von 50 Metern. Bei Infrarot-Nachtsicht beträgt die Sichtweite etwa 15 Meter.

2. Die Smart Outdoor Camera zeigt nach dem Verbinden den Status "offline" an.

- Stellen Sie sicher, dass das WLAN-Passwort für Ihr Heimnetzwerk im Einstellungsmenü der "Doby" App korrekt eingegeben ist.
- Stellen Sie sicher, dass Ihr Mobilgerät mit demselben WiFi-Netzwerk wie Ihre Kamera verbunden ist, um die erste Verbindung herzustellen.

3. Die SD-Karte wird nicht erkannt.

Bitte stellen Sie sicher, dass die SD-Karte als FAT32 formatiert ist.

6. TECHNISCHE EIGENSCHAFTEN

Linse:	Weitwinkelobjektiv
Winkel:	Diag. 105, horiz. 90, vert. 60
Videokompression:	H.264
Auflösung:	1280 × 960 @ 15fps
Audio:	Einzelmikrofon
WiFi Protokoll:	IEEE802.11 b / g / n / (2,4 GHz)
Verschlüsselung:	WPA2 / WPA / WEP / OPEN
Netzwerk:	Wi-Fi / Cadle RJ45
Leistung:	12V / 1A
Betriebsbedingungen:	Temperatur -30 ~ 60°C, Luftfeuchtigkeit <90%
Größe:	67 × 105 × 145mm

1. CONTENIDO DEL PAQUETE

Por favor, compruebe que la cámara esté intacta y que se incluyan todos los accesorios.

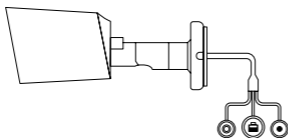

Cámara x1



Manual del usuario x1

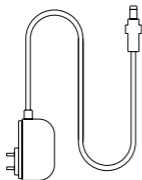

Adaptador de corriente x1



Conjunto de sellado para cable x1



Antenna x1



Hebilla de línea x4



Tornillos x4



Cinta adhesiva impermeable x2

2. APARIENCIA

Por favor, ajuste el ángulo de instalación y apriete los tres tornillos como se muestra en la imagen. Para reajustar el ángulo, afloje antes los tornillos.

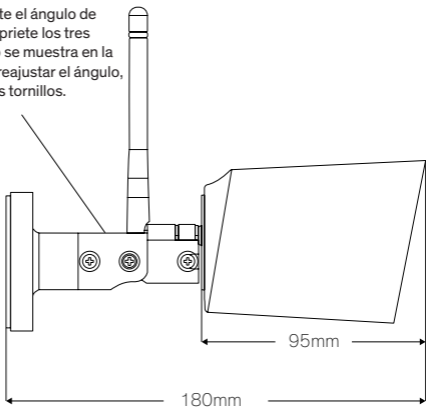

Nota:

Tenga en cuenta que múltiples reajustes del ángulo pueden desgastar los tornillos (el pasador desgastará las juntas).

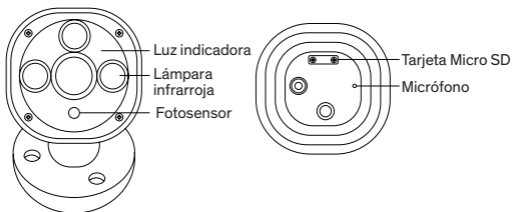

3. INSTRUCCIONES DE INSTALACIÓN

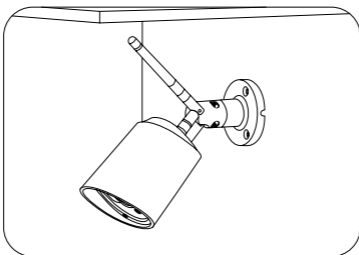

Montaje en pared

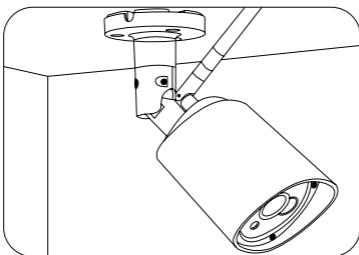

Montaje en techo

Nota:

1. Por favor, preste atención a las medidas de protección contra el agua para la instalación en exteriores. Observe las imágenes siguientes para entender las instrucciones detalladas.
2. Por favor, preste atención a las medidas de protección contra rayos en exterior.

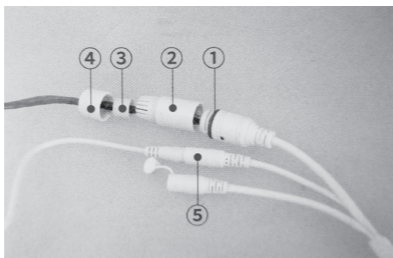

- Encaje el anillo rojo O en la base del puerto de red ①.
- Ajuste las piezas ①, ②, ③, y ④.
- Conecte el cable de corriente al puerto de alimentación ⑤.

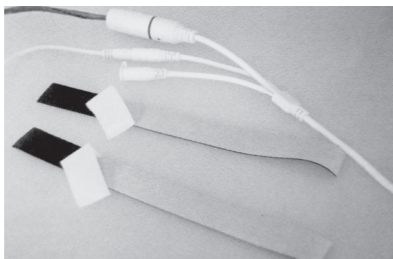

- Retire el papel de la cinta adhesiva impermeable.



- Cuando aplique la cinta impermeable, manténgala tensa estirándola antes de adherirla. De este modo dará mejor rendimiento.

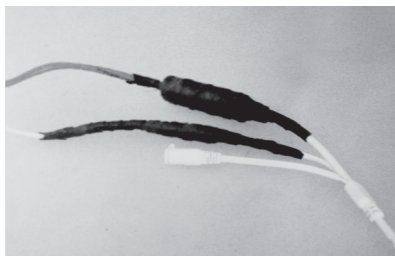

- El resultado después de envolver la cinta impermeable.

4. INSTRUCCIONES DE USO

1. Conectar la Smart Outdoor Camera

Conecte la SmartOutdoor Camera a una fuente de alimentación utilizando el adaptador de corriente incluido.

2. Instalación de la App

Abra "Doby" [Home] y pulse "+" para buscar dispositivos. Seleccione "Camera (Outdoor Version)".



Regístrese con su dirección de correo electrónico y elija una contraseña. Si ya tiene una cuenta, haga clic en "Sign in".



3. Añadir un dispositivo

Abra "Doby" [Home] y pulse "+" para buscar dispositivos. Seleccione "Camera (Outdoor Version)".

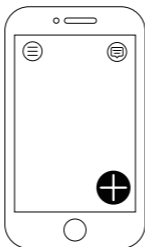

Conexión por cable

Por favor, compruebe que la cámara y la app estén conectadas a la misma red y que el indicador LED de red esté encendido. Seleccione el dispositivo CID y haga clic en "Next".

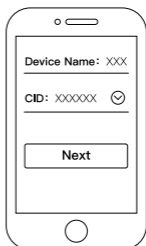
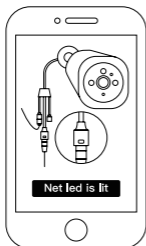

Conexión WiFi

- Asegúrese de que el indicador WiFi de la Smart Outdoor Camera parpadea en azul. Si no, mantenga pulsado el botón WiFi durante unos segundos hasta que el indicador WiFi parpadee.

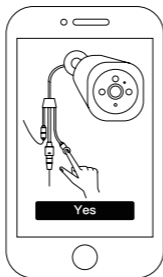

- Vaya a [Settings]>[Wi-Fi] en su dispositivo móvil, conéctelo a DOG-00*** e introduzca el código "11111111". Vuelva a la aplicación Doby y haga clic en "Next".



- Escoja un nombre de dispositivo, por ejemplo, "Jardín". Escoja una red e introduzca la contraseña. Pulse "Next". La Smart Outdoor Camera empezará el proceso de conexión con la red y el indicador WiFi parpadeará en rojo. Pueden pasar unos minutos hasta que se establezca la conexión. Cuando el indicador WiFi se ponga azul, la cámara se habrá conectado con éxito. Dele a "Done" en su dispositivo móvil. Ya puede utilizar la Smart Outdoor Camera.

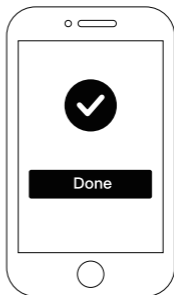
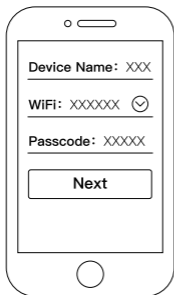

5. PROBLEMAS Y SOLUCIONES

1. ¿Cuál es el alcance de supervisión de la cámara?

Con luz de día la cámara tiene un alcance visual de 50 metros. Con la visión infrarroja nocturna la distancia visual es de unos 15 metros.

2. La Smart Outdoor Camera pone en su status “offline” después de conectarla.

- Asegúrese de que la contraseña WiFi de su red doméstica esté correctamente introducida en el menú de configuración de la aplicación “Doby”.
- Asegúrese de que su dispositivo móvil esté conectado a la misma red WiFi que la cámara para realizar la conexión inicial.

3. No se detecta la tarjeta SD.

Asegúrese de que la tarjeta SD esté formateada como FAT32.

6. ESPECIFICACIONES TÉCNICAS

Lente:	Lente de gran angular
Ángulo:	Diagonal 105, horizontal 90, vertical 60
Compresión de vídeo:	H.264
Resolución:	1280 × 960@15fps
Audio:	Micrófono único
Protocolo de soporte WiFi:	IEEE802.11 b/g/n/ (2.4GHz)
Encriptación:	WPA2/WPA/WEP/OPEN
Red:	WiFi/Cable RJ45
Potencia:	12V/1A
Condiciones de operación:	Temperatura -30~60C, Humedad <90%
Dimensiones:	67 × 105 × 145mm

1. CONTENUTO DELLA CONFEZIONE

Si prega di verificare che la fotocamera sia intatta e che tutti gli accessori siano inclusi.

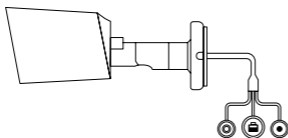

Telecamera x1



Manuale utente x1

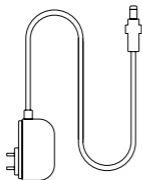

Alimentatore x1



Set di tenuta per cavo x1



Antenna x1



Passacavo x4

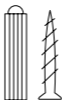

Vite x4



Nastro impermeabile x2

2. ASPETTO

Si prega di regolare l'angolo di installazione e stringere le tre viti come mostrato nell'immagine. Per regolare nuovamente l'angolo, allentare le viti prima della regolazione.

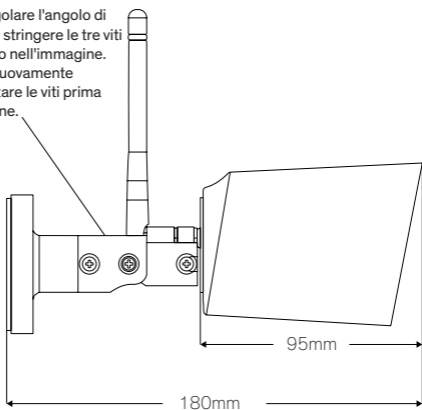

Nota:

Si prega di notare che la ripetuta regolazione dell'angolo può causare l'usura delle viti (il fermo tende ad usurare i giunti).

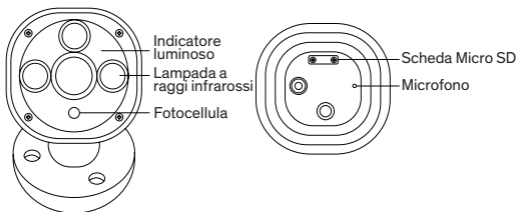

3. ISTRUZIONI DI MONTAGGIO

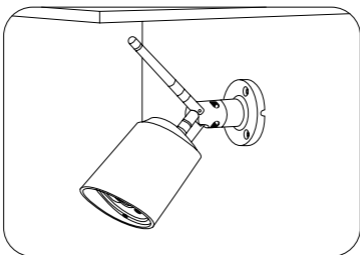

Montaggio a parete

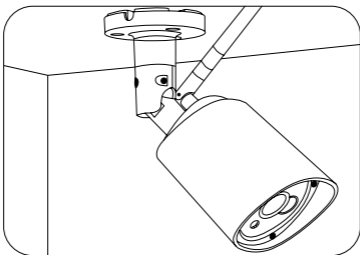

Montaggio a soffitto

Nota:

1. In caso di installazione all'esterno si prega di prestare attenzione agli accorgimenti per l'impermeabilizzazione. Consultare le seguenti immagini per una spiegazione dettagliata.
2. Prestare attenzione alla protezione antifulmine esterna.

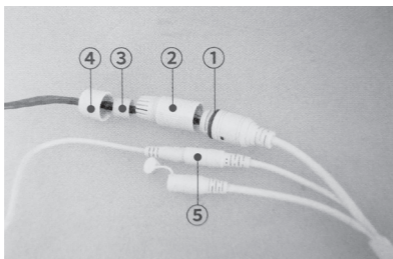

- Montare l'O-ring rosso nella sede della porta di rete ①.
- Stringere le parti ①, ②, ③, e ④.
- Collegare il cavo di alimentazione alla porta di alimentazione ⑤.

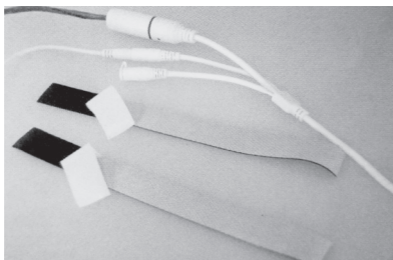

- Rimuovere la carta sul retro del nastro impermeabile.



- Durante l'applicazione del nastro impermeabile, mantenere la tensione sul nastro tendendolo durante il montaggio. In questo modo il nastro impermeabile si applica nel modo migliore.

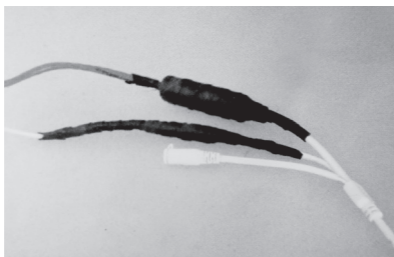

- Il risultato dopo aver avvolto il nastro impermeabile.

4. ISTRUZIONI D'USO

1. **Connessione della Smart Outdoor Camera**

Collegare la Smart Outdoor Camera a una fonte di alimentazione usando l'alimentatore incluso.

2. **Installazione dell'app**

Andare sull'App Store del proprio dispositivo mobile per scaricare l'app "Doby".



Registrarsi con il proprio indirizzo email e scegliere una password. Se si dispone già di un account, toccare su "Accedi".

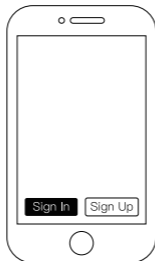

3. Aggiungere un dispositivo

Aprire "Doby" [Home], toccare "+" per cercare i dispositivi. Scegliere "Camera (Outdoor Version)".

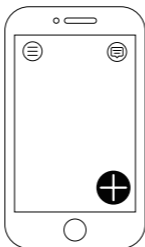

Connessione via cavo

Si prega di verificare che la fotocamera e l'app siano collegate alla stessa rete e che l'indicatore led di rete sia acceso. Selezionare il CID del dispositivo e toccare "Proseguì".

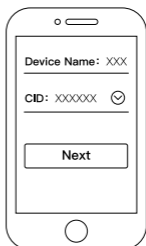
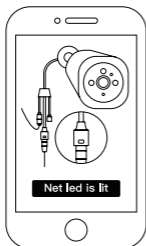

Connessione Wi-Fi

- Assicurarsi che l'indicatore WiFi sulla Smart Outdoor Camera lampeggi col colore blu. In caso contrario, tenere premuto il pulsante Wi-Fi per alcuni secondi fino a quando l'indicatore Wi-Fi non lampeggia.

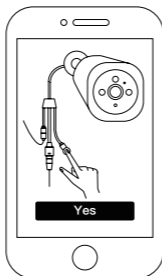

- Attraverso [Impostazioni]>[Wi-Fi] sul dispositivo mobile, connettersi a DOG-00*** e inserire il codice "11111111". Tornare all'app Doby e toccare "Prosegui".



- Scegliere un nome per il dispositivo, ad esempio "Giardino"
Scegliere una rete e inserire la password. Toccare "Prosegui".
La Smart Outdoor Camera avvierà la connessione alla rete e l'indicatore Wi-Fi lampeggerà col colore rosso. Potrebbero essere necessari alcuni minuti per stabilire la connessione. Quando l'indicatore Wi-Fi diventa blu, la fotocamera è collegata correttamente. Toccare "Fatto" sul proprio dispositivo mobile. Ora la Smart Outdoor Camera è pronta da usare.

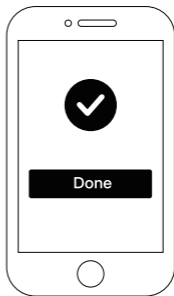
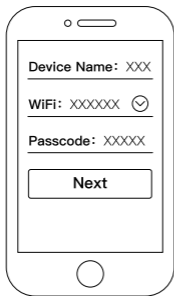

5. PROBLEMI E SOLUZIONI

1. Quanto è ampio il raggio di monitoraggio?

In luce del giorno, la fotocamera garantisce una distanza visiva di 50 metri. Con la visione notturna a infrarossi la distanza visiva è di circa 15 metri.

2. La Smart Outdoor Camera visualizza lo stato "disconnesso" dopo la connessione.

- Assicurarsi che la password Wi-Fi della rete domestica sia digitata correttamente nel menu delle impostazioni dell'applicazione "Doby".
- Per effettuare la connessione iniziale, assicurarsi che il proprio dispositivo mobile sia connesso alla stessa rete Wi-Fi della videocamera.

3. La scheda SD non viene rilevata.

Assicurarsi che la scheda SD sia formattata come FAT32.

6. SPECIFICHE TECNICHE

Obiettivo:	Obiettivo grandangolare
Angolo:	Diag. 105, orizz. 90, vert. 60
Compressione video:	H.264
Risoluzione:	1280 × 960@15fps
Audio:	Microfono singolo
Supporto protocollo Wi-Fi:	IEEE802.11 b/g/n/ (2,4 GHz)
Crittografia:	WPA2/WPA/WEP/OPEN
Rete:	Wi-Fi/Cavo RJ45
Alimentazione:	12V/1A
Condizioni operative:	Temperatura -30 ~ 60 °C, Umidità <90%
Dimensioni:	67 × 105 × 145 mm

1. CONTEÚDO DA EMBALAGEM

Por favor, verifique se a câmara está intacta e se todos os acessórios estão incluídos.

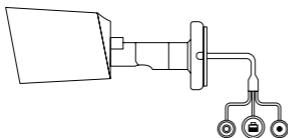

Câmara x1



Manual de utilizador x1

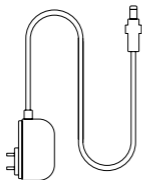

Adaptador de corrente x1



Kit de braçadeira x1



Antena x1



Encaixe de fio x4



Parafuso x4



Fita adesiva impermeável x2

2. ASPETO VISUAL

Ajuste o ângulo de instalação e aperte os três parafusos conforme mostrado na imagem. Para reajustar o ângulo, solte os parafusos antes de os ajustar.

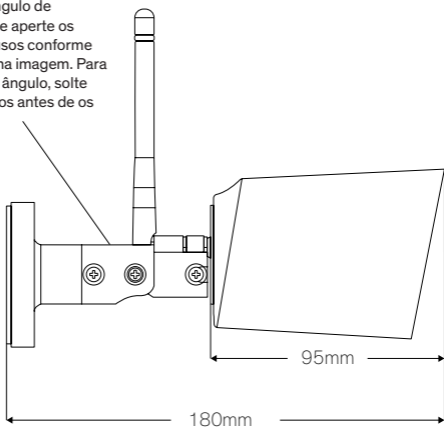

Nota:

Repare que ajustar o ângulo muitas vezes pode causar desgaste dos parafusos (a peça de fecho desgastará as juntas).

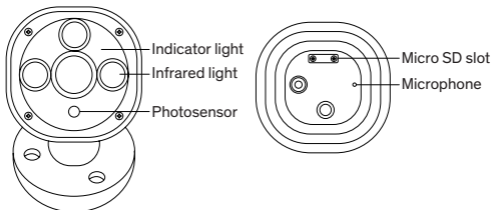

3. INSTRUÇÕES DE INSTALAÇÃO

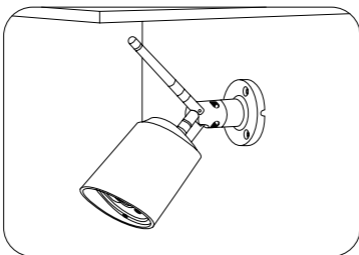

Montagem na parede

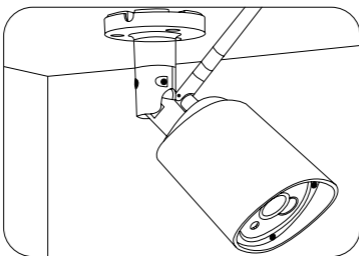

Montagem no teto

Nota:

1. Preste atenção às medidas de impermeabilização para instalação no exterior. Veja as imagens seguintes para uma instrução detalhada.
2. Preste atenção à proteção contra raios no exterior.

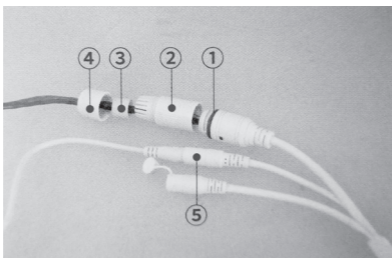

- Coloque o anel de vedação (anel O-ring) vermelho na entrada da porta de rede. ①.
- Aperte as peças ①, ②, ③ e ④.
- Ligue o cabo elétrico à porta de alimentação ⑤.

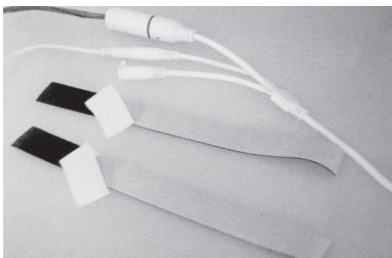

- Remova o papel da parte de trás da fita adesiva impermeável.



- Ao aplicar a fita adesiva impermeável, mantenha a tensão da fita, esticando-a durante a montagem. Desta forma, a fita impermeável atuará melhor.

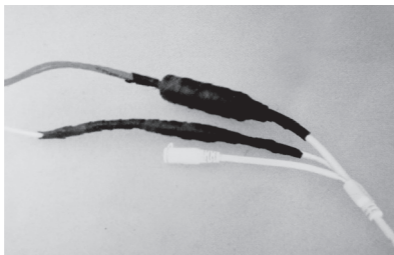

- O resultado depois de aplicar a fita adesiva impermeável.

4. INSTRUÇÕES DE UTILIZAÇÃO

1. Ligar a Smart Outdoor Camera

Ligue a Smart Outdoor Camera a uma tomada utilizando o adaptador de corrente incluído.

2. Instalação da App

Vá à App Store do seu dispositivo móvel para descarregar a aplicação “Doby”.



Registe-se com o seu endereço de e-mail e escolha uma palavra-passe. Caso já tenha uma conta, seleccione “Iniciar sessão” (Login).



3. Adicionar Dispositivo

Abra “Doby” [Ecrã inicial], toque em “+” para procurar dispositivos. Escolha “Camera (Outdoor Version)” [Câmara (Versão para exterior)].

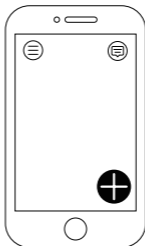

Ligação com cabos

Verifique se a câmara e a aplicação estão ligadas à mesma rede e que a luz indicadora de rede está acesa. Selecione o ID do dispositivo e toque em “Seguinte”.

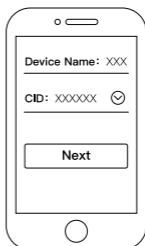
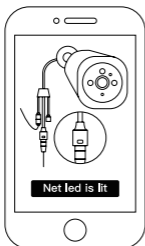

Ligação wi-fi

- Certifique-se de que a luz indicadora de wi-fi na Outdoor Camera (Câmara Exterior) está a piscar a azul. Se não estiver, prima e mantenha o botão wi-fi durante alguns segundos, até a luz indicadora começar a piscar.

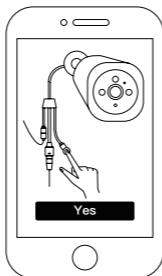

- Através de [Configurações]>[Wi-Fi] no seu dispositivo móvel, ligue-se a DOG-00***, introduza o código "11111111". Volte à aplicação Doby e toque em "Seguinte".



- Escolha um nome para o dispositivo – por exemplo “Jardim”. Selecione a rede e introduza a palavra-passe. Toque em “Seguinte”. A Smart Outdoor Camera começará a ligar-se à rede e a luz indicadora de wi-fi, começará a piscar a vermelho. Pode levar alguns minutos até que a ligação seja estabelecida. Quando a luz indicadora de wi-fi passart a azul, a ligação à câmara foi bem-sucedida. Clique em “Sair” no seu dispositivo móvel. Está agora pronta/o a utilizar a Smart Outdoor Camera.

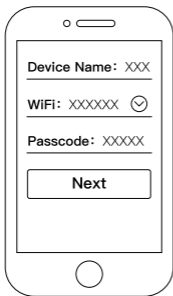

5. PROBLEMAS E SOLUÇÕES

1. Qual é o alcance da vigilância?

Com luz natural, a câmara tem uma distância visual de 50 metros. Com a visão noturna por infravermelhos, a distância visual é de cerca de 15 metros.

2. A câmara apresenta o estado do “offline” depois de efetuada a ligação.

- Assegure-se de que a palavra-passe wi-fi da sua rede doméstica foi introduzida corretamente no menu de configurações da aplicação “Doby”.
- Assegure-se de que o seu dispositivo móvel está ligado à mesma rede wi-fi do que a câmara para fazer a ligação inicial.

3. O Cartão SD Card não é detetado.

Assegure-se de que o cartão SD está formatado no sistema de ficheiros FAT32..

6. ESPECIFICAÇÕES TÉCNICAS

Lente:	lente grande angular
Ângulo:	diag 105°, horiz 90°, vert 60°
Compressão de vídeo:	H.264
Resolução:	1280 × 960 @15fps
Áudio:	Microfone simples
Protocolo Wi-Fi:	IEEE802.11 b/g/n (2.4GHz)
Encriptação:	WPA2 / WPA / WEP / OPEN
Rede:	Wi-Fi/Cable RJ45
Alimentação:	12V/1A
Condições de Funcionamento:	Temperatura -30~60°C,
Humidade	<90%
Dimensões:	67 × 105 × 145mm



SINJI

Made in China

www.sinjiproducts.com

© 2018 SINJI. All rights reserved.