



Architecture

21035

Solomon R. Guggenheim Museum®

New York City, USA



[LEGO.com/architecture/booklet](https://www.lego.com/architecture/booklet)

Solomon R. Guggenheim Museum



Widely regarded as an exceptional icon of the 20th century, the Solomon R. Guggenheim Museum launched the great age of museum architecture and proved that a collection's physical home could be as crucial a part of the museum experience as the work itself.



The Story of an Iconic Building

In June 1943, Frank Lloyd Wright was asked by Hilla Rebay, the art advisor to Solomon R. Guggenheim, to design a new building to house Guggenheim's four-year-old Museum of Non-Objective Painting.

The project would evolve into a complex struggle pitting the architect against his clients, city officials, the art world and public opinion. It would take over 15 years, 700 sketches and seven complete sets of working drawings before Wright's vision would be realized and the Solomon R. Guggenheim Museum would open its doors for the first time in 1959. By then both Guggenheim and Wright had died.

The location of the Guggenheim Museum on Fifth Avenue between 88th and 89th Streets is not accidental. Its proximity to Central Park was key; as close to nature as one can get in New York, the park affords relief from the noise and congestion of the city.

Nature not only provided the museum with a respite from New York's distractions, but also lent it inspiration. The Guggenheim Museum is an embodiment of Frank Lloyd Wright's attempts to utilize organic forms in architecture.

But even as it embraced nature, Wright's design also expresses his unique take on modernist architecture's rigid geometry. The building is a symphony of triangles, ovals, arcs, circles and squares.

Wright dispensed with the conventional approach to museum design, which led visitors through a series of interconnected rooms. Instead, he whisked people to the top of the building via elevator and led them downward at a leisurely pace on the gentle slope of a continuous ramp. The open rotunda afforded viewers the unique possibility of seeing several bays of work on different levels simultaneously.

The building itself has often been called the most important piece of art in the Guggenheim collection.

*["An idea is salvation
by imagination"]*

Frank Lloyd Wright



T H E S O L O M O N R G U G G E N H E I M M U



The Story Continues

When the museum opened to an enthusiastic public on October 21, 1959, just six months after Frank Lloyd Wright's death, the relationship between the breathtaking architecture of the building and the art it was built to display inspired both controversy and debate. One critic wrote that the museum "turned out to be the most beautiful building in America... never for a minute dominating the pictures being shown," while another insisted that the structure was "less a museum than a monument to Frank Lloyd Wright."

Wright had originally suggested the construction of a tall building behind the museum itself to house its administration and provide the perfect backdrop to his structure, but it would be 1992 before this was finally achieved.

Today the Guggenheim collection has grown substantially and is now shared with other sister museums around the world. The New York museum, however, remains the spiritual home of the collection and receives over one million visitors every year.





About the Architect

Arguably America's greatest architect and among the world's most gifted, Frank Lloyd Wright was also a man of boundless energy. In a career that spanned over 74 years, he designed more than 900 works – including houses, offices, churches, schools, libraries, bridges, museums and many other building types. Of that total, over 500 resulted in completed works. Today, over 400 of these buildings still remain.

Wright's creative mind was not only confined to architecture. He also designed furniture, fabrics, art glass, lamps, dinnerware, silver, linens and graphic arts. In addition, he was a prolific writer, an educator and a philosopher. He authored twenty books and countless articles and lectured throughout the United States, as well as in Europe.

Wright was born in 1867 in the rural farming town of Richland Center, Wisconsin, just two years after the American Civil War ended, and passed away at the age of 91 in 1959. While there is evidence of Wright attending both high school and the University of Wisconsin-Madison, there is no record of him graduating from either. In 1887 Wright moved to Chicago and by the early 1890s he was already head draftsman at the architectural firm of Adler & Sullivan.

Wright was recognized as a brilliant architect by his peers and continues to be revered today. No other architecture took greater advantage of setting and environment. No other architect glorified the sense of "shelter" as did Frank Lloyd Wright. As he famously stated: "A building is not just a place to be. It is a way to be."



Facts

Architect: Frank Lloyd Wright
Classification: Art Museum
Location: New York City, New York, USA
Architectural Style: Modern Movement
Height: 92 ft. (28 m)
Materials: Aluminum, Steel, Concrete
and Glass
Year: 1943-1959

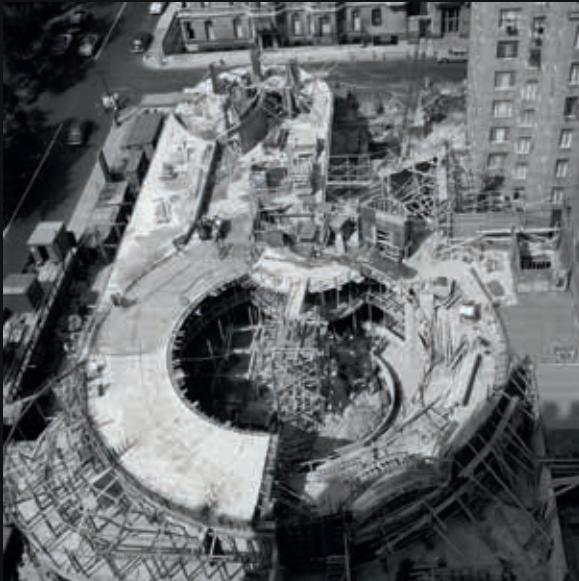

©The Solomon R. Guggenheim Foundation, New York



©The Solomon R. Guggenheim Foundation, New York



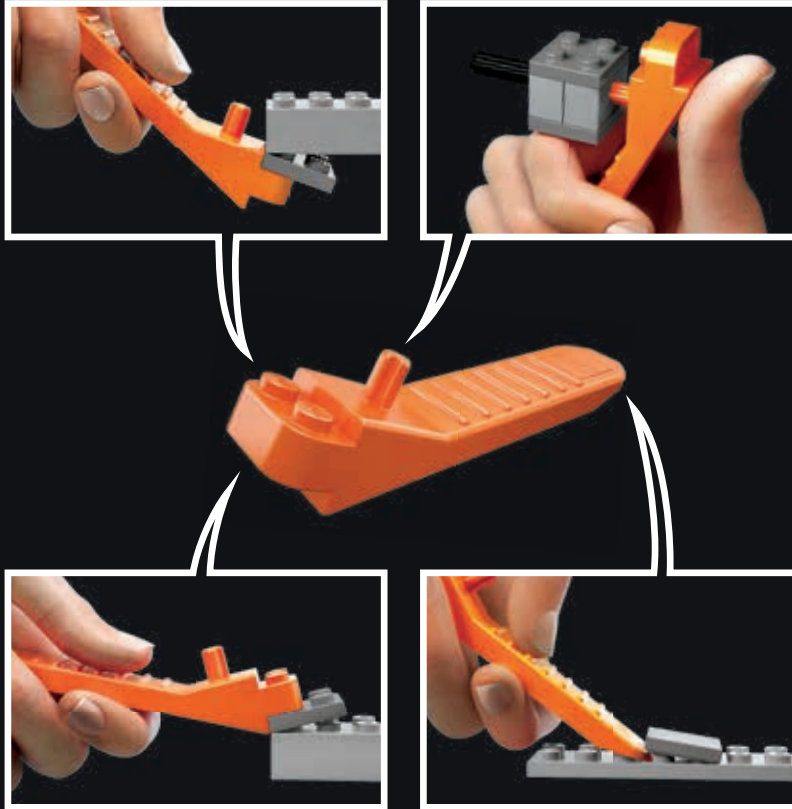

LEGO.com/brickseparator

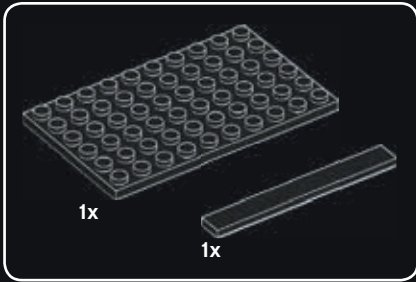
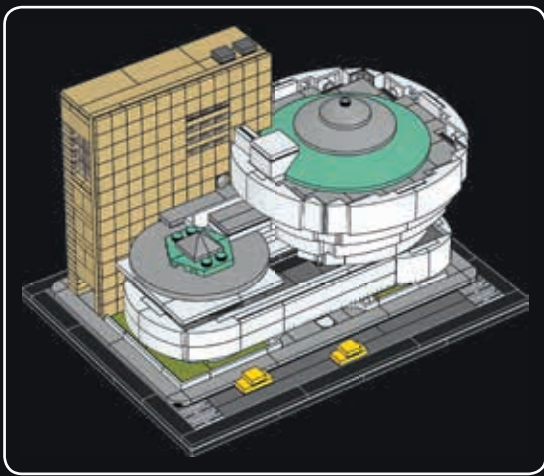

1

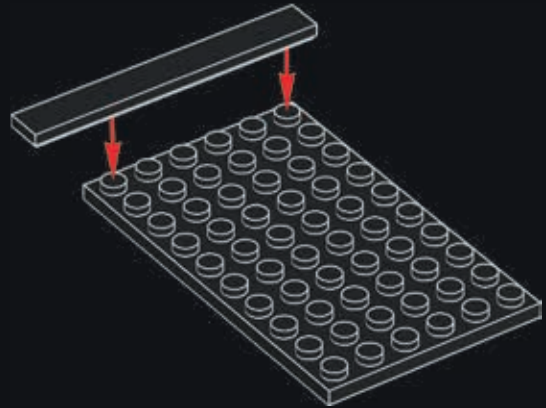

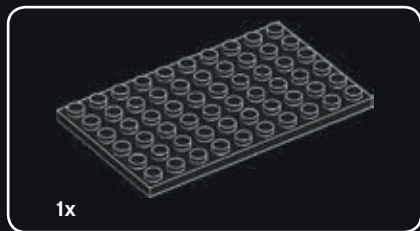

2

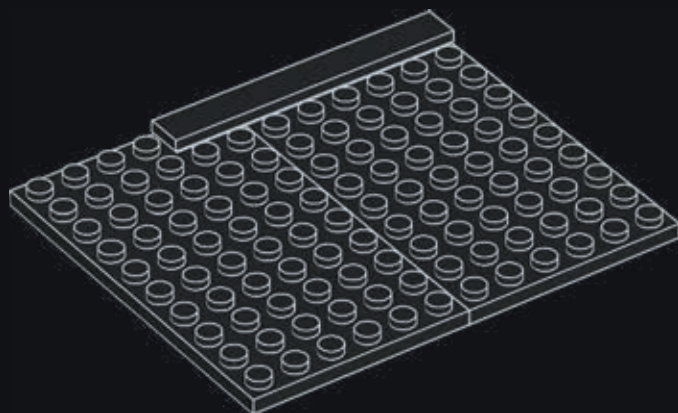



3

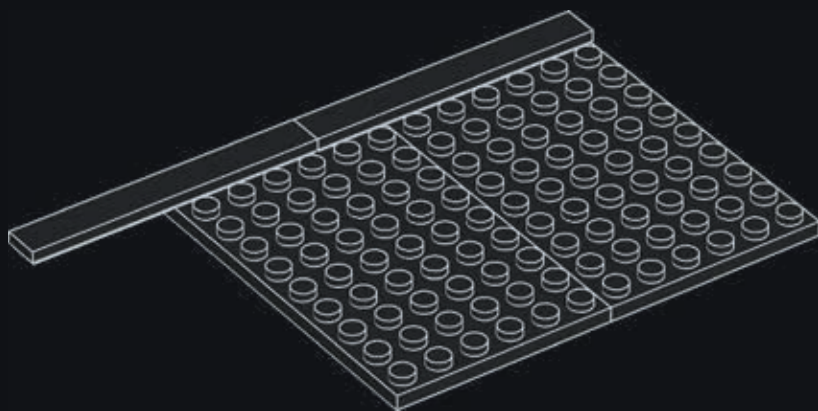

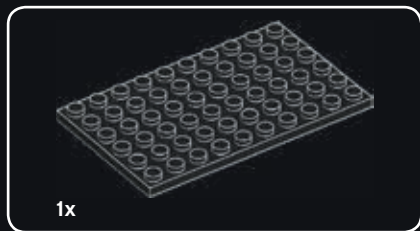

4

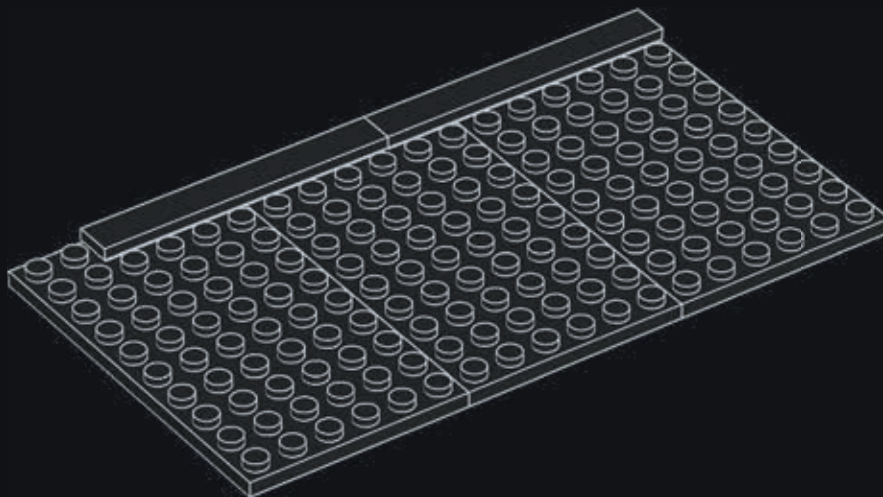



5

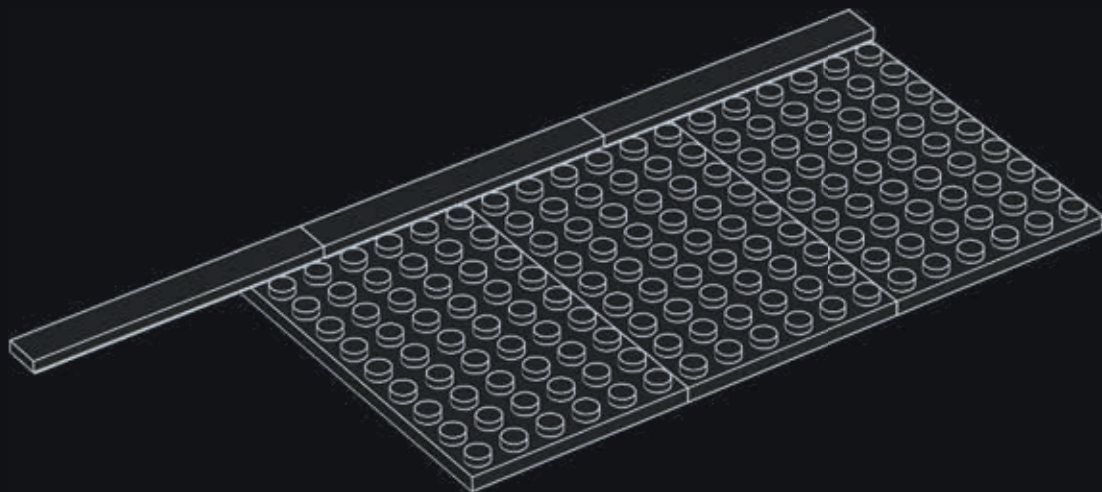

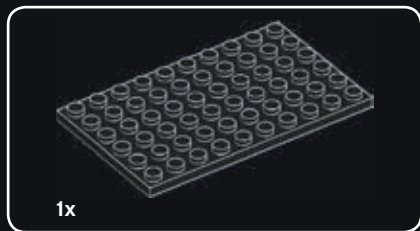

6

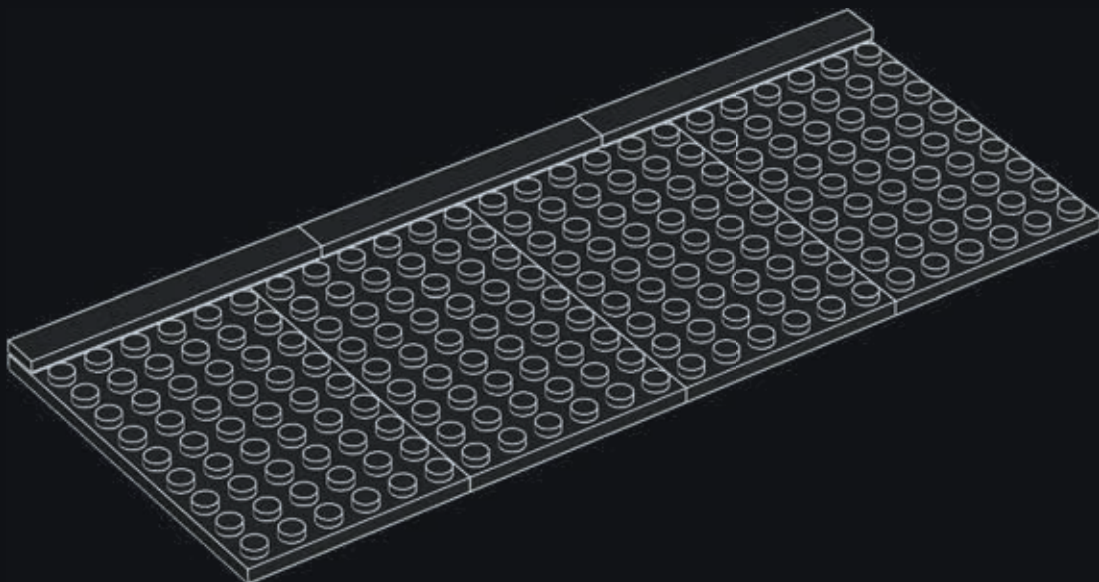

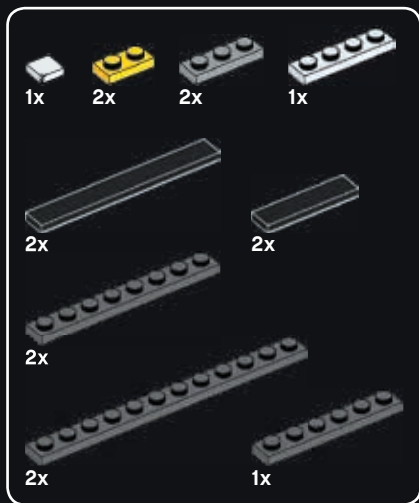

7

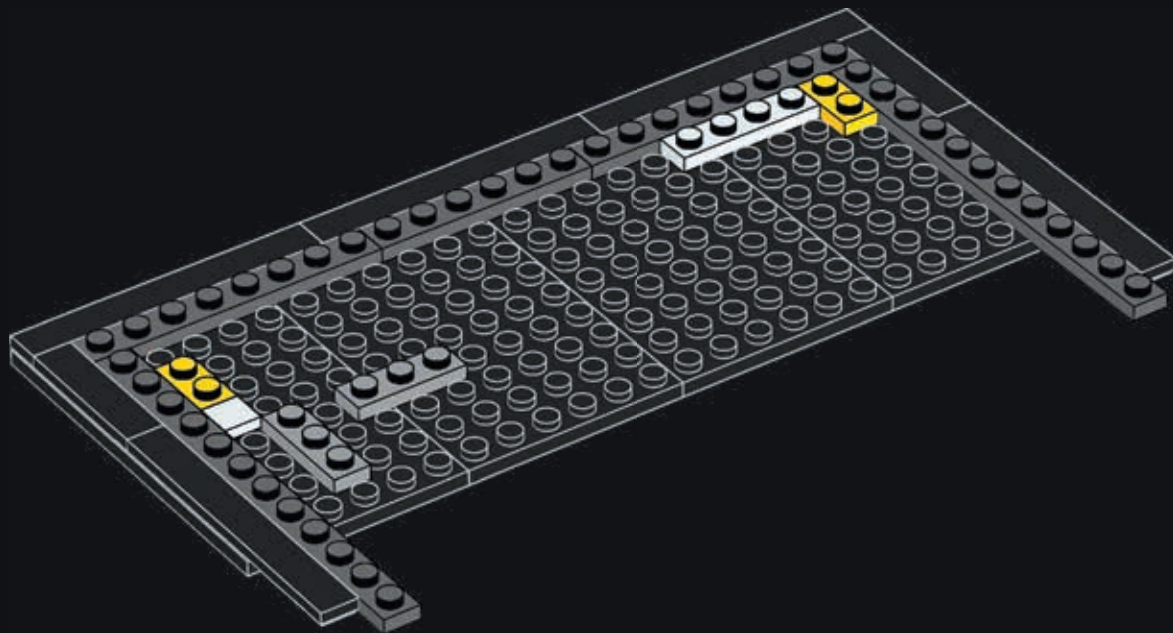

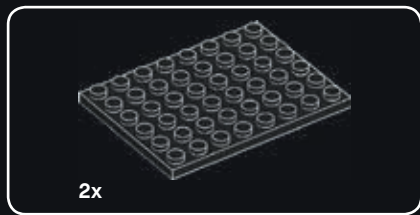

8

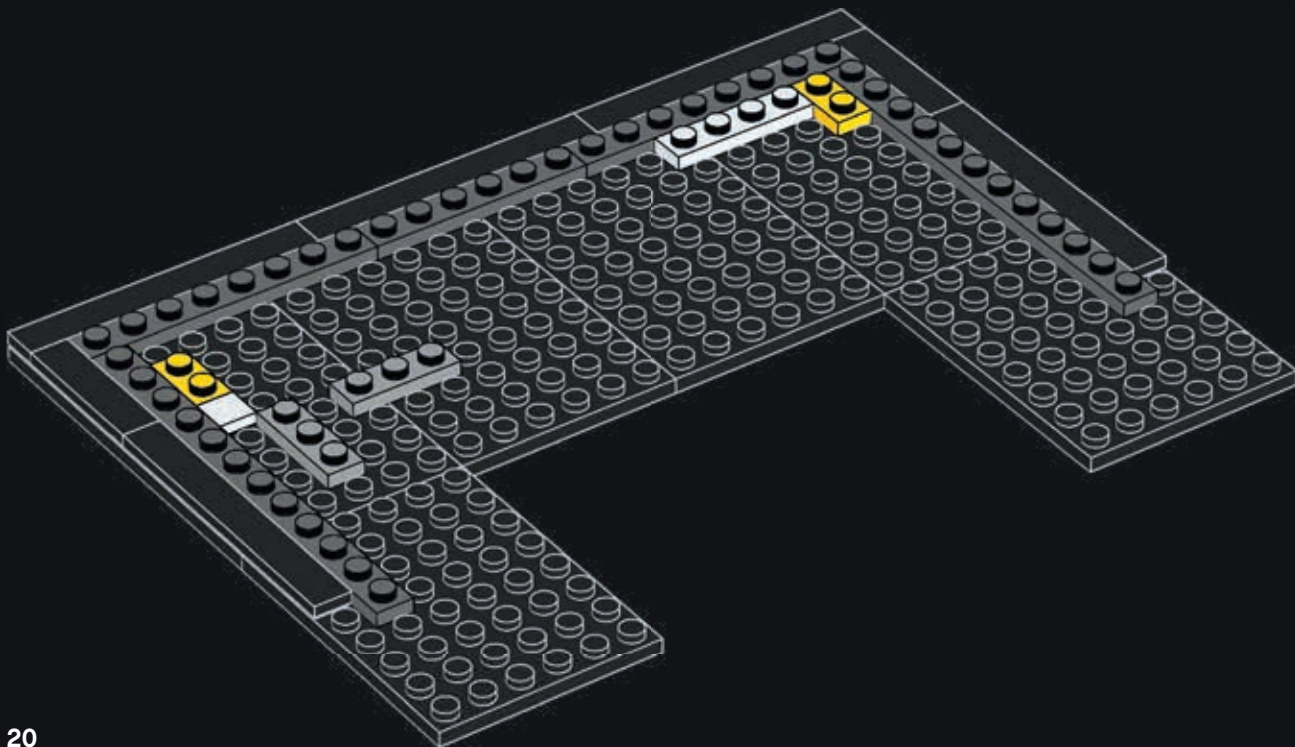

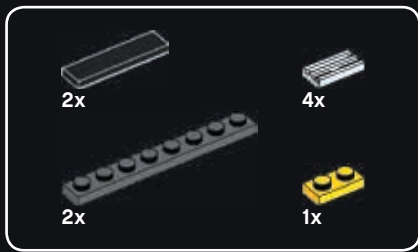

9

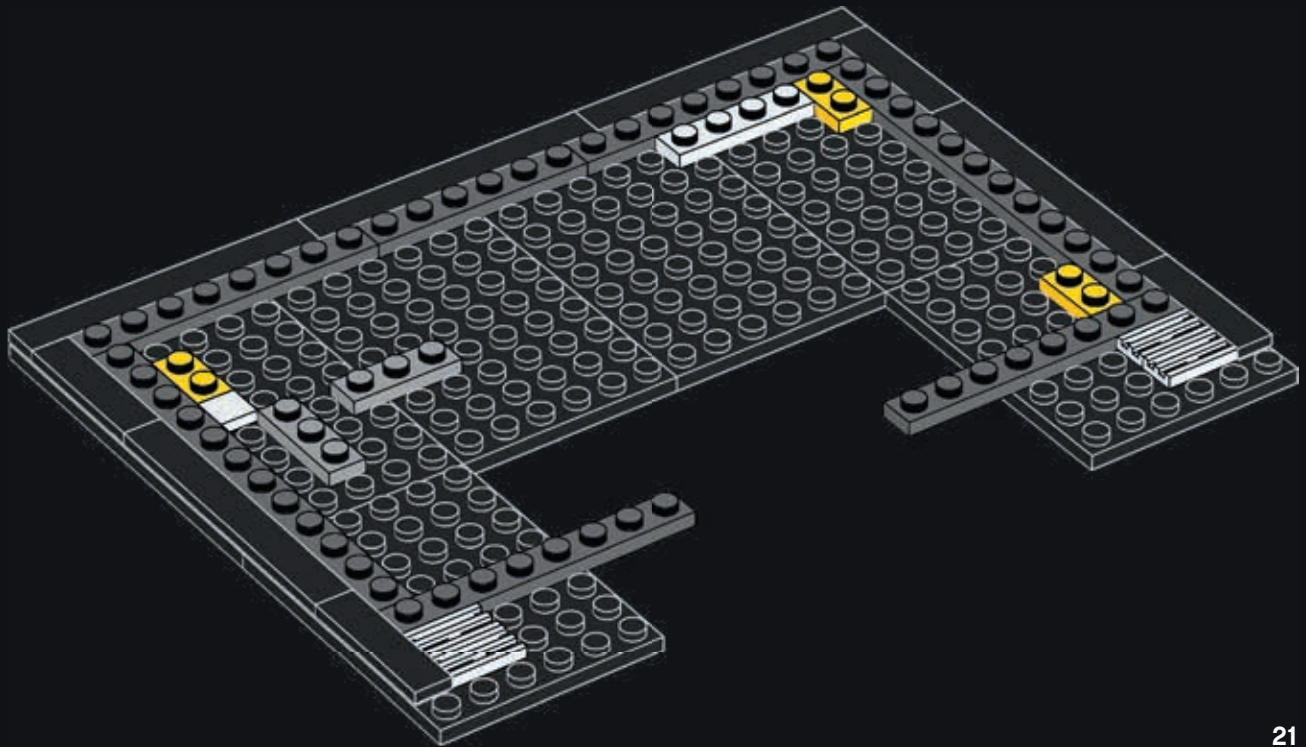

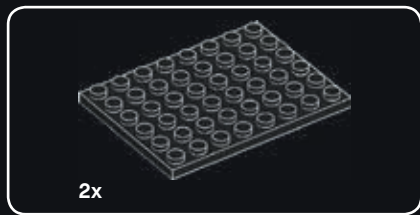

10

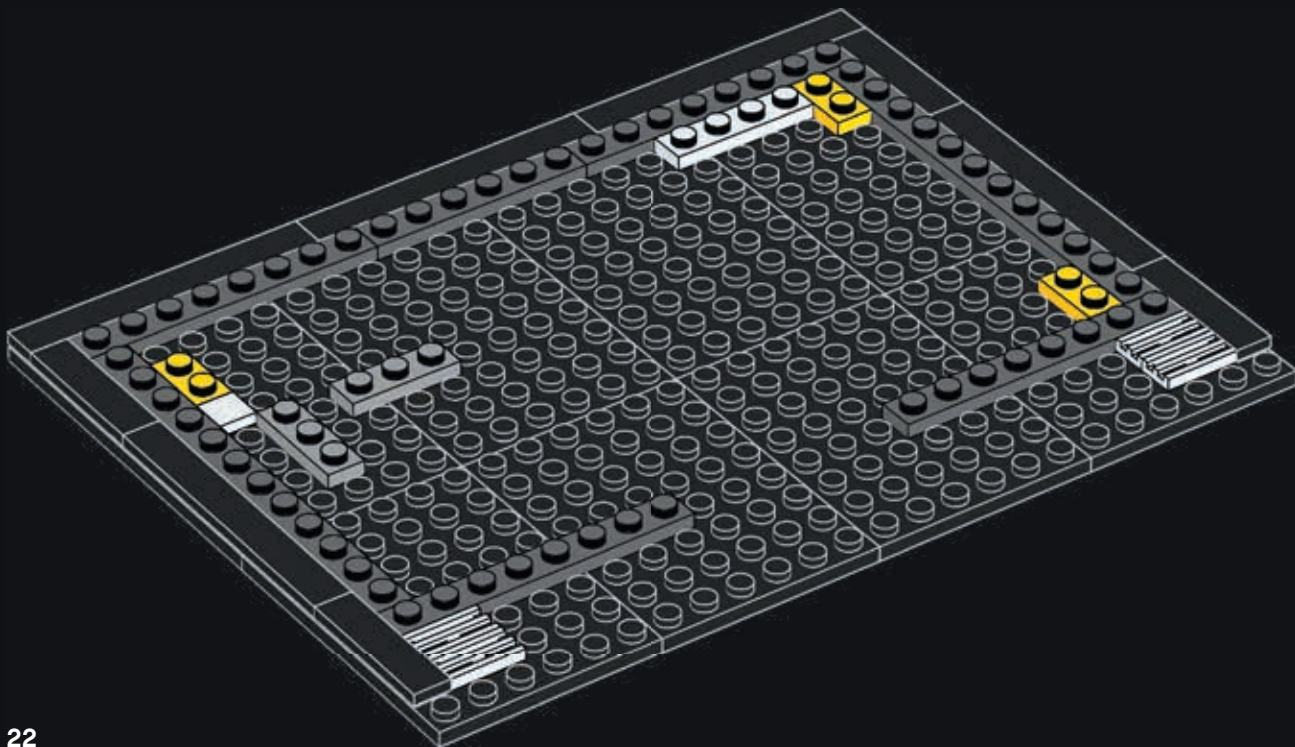

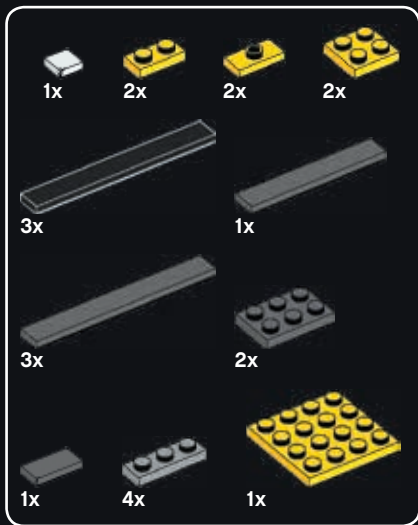

Frank Lloyd Wright insisted on designing every detail in the Guggenheim Museum, right down to the chairs and elevators.



11

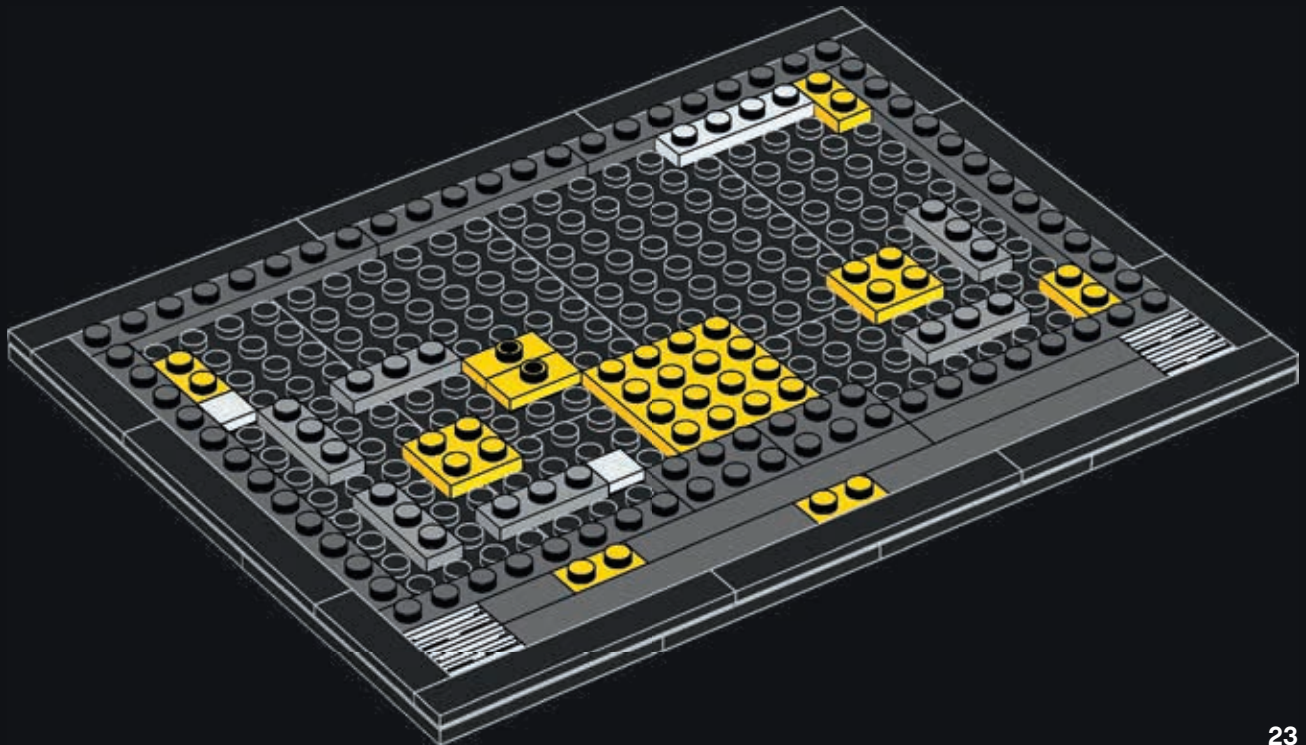

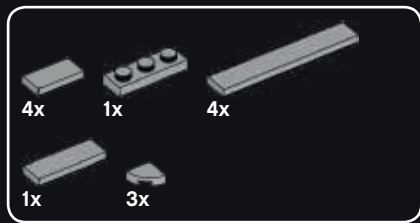

12

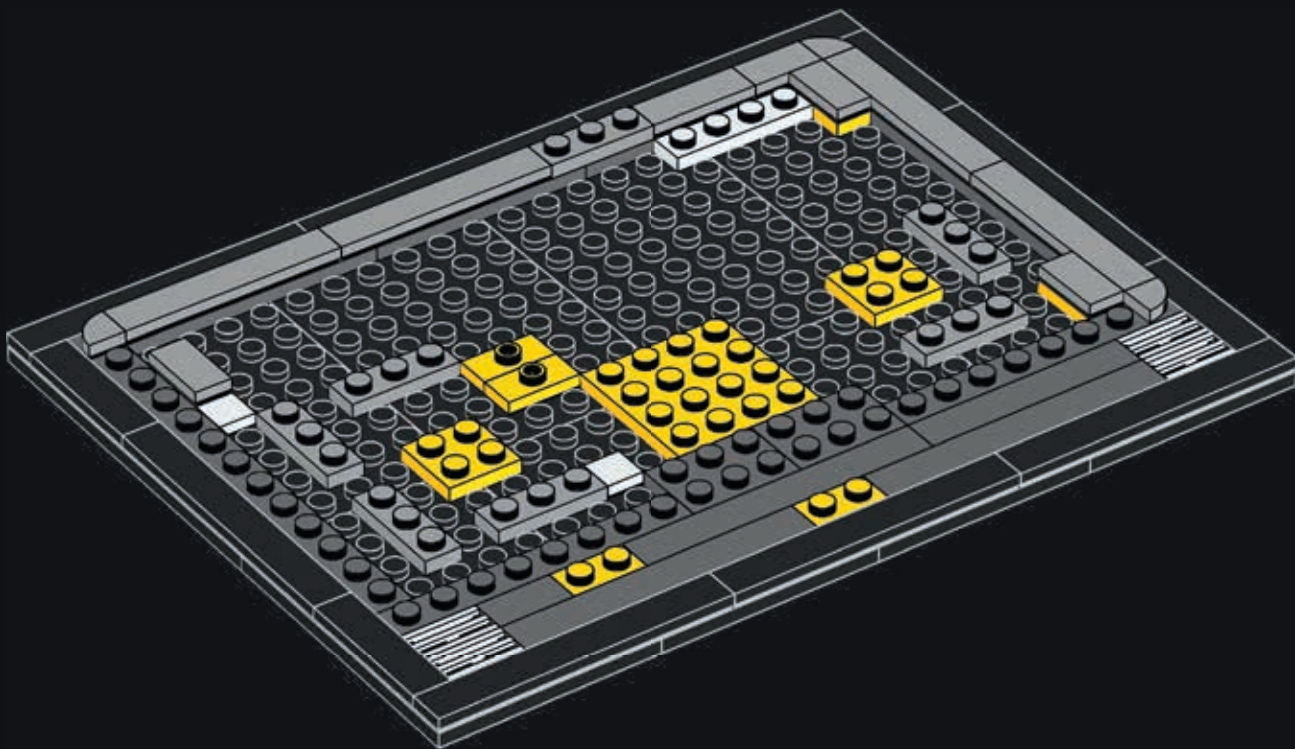

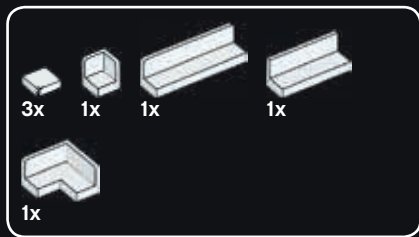

13

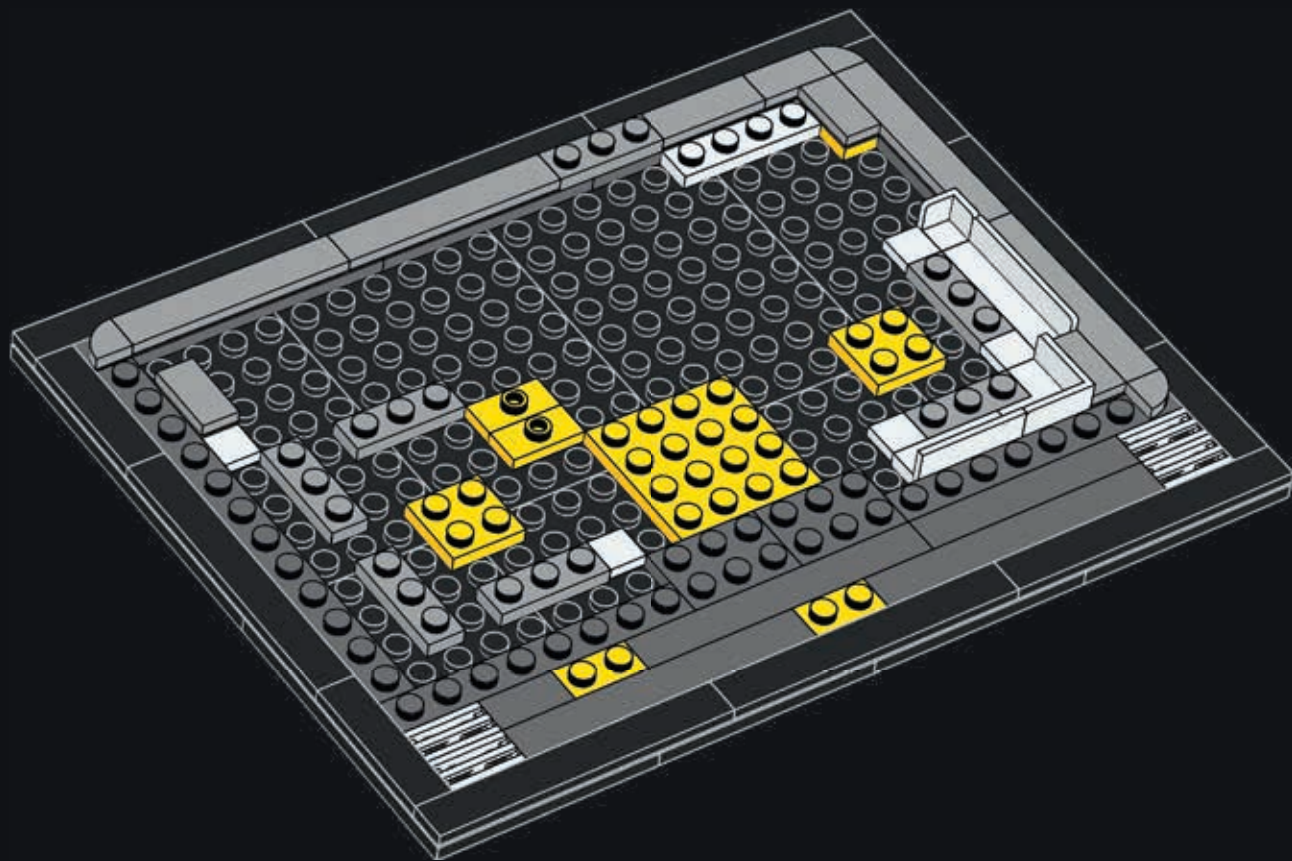



2x

14

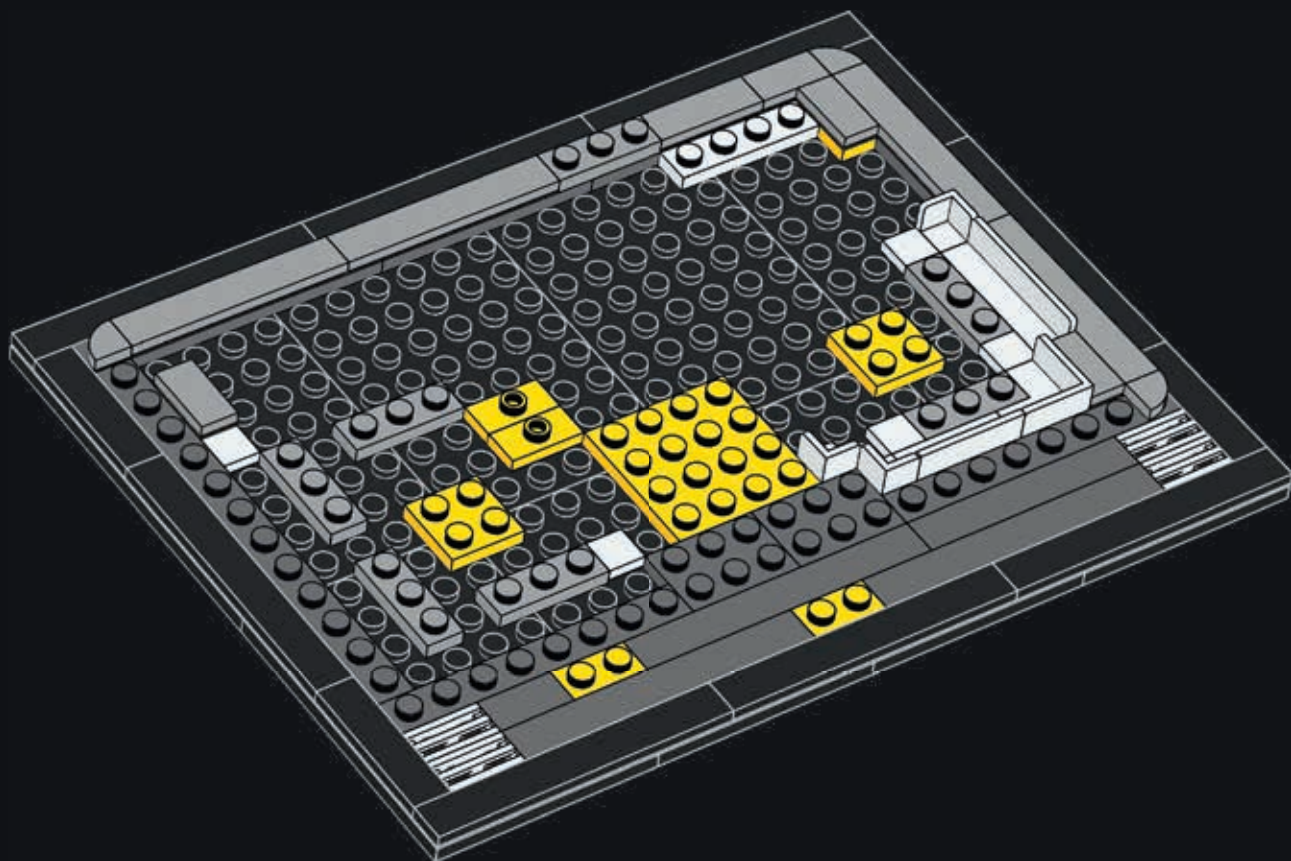



4x

15

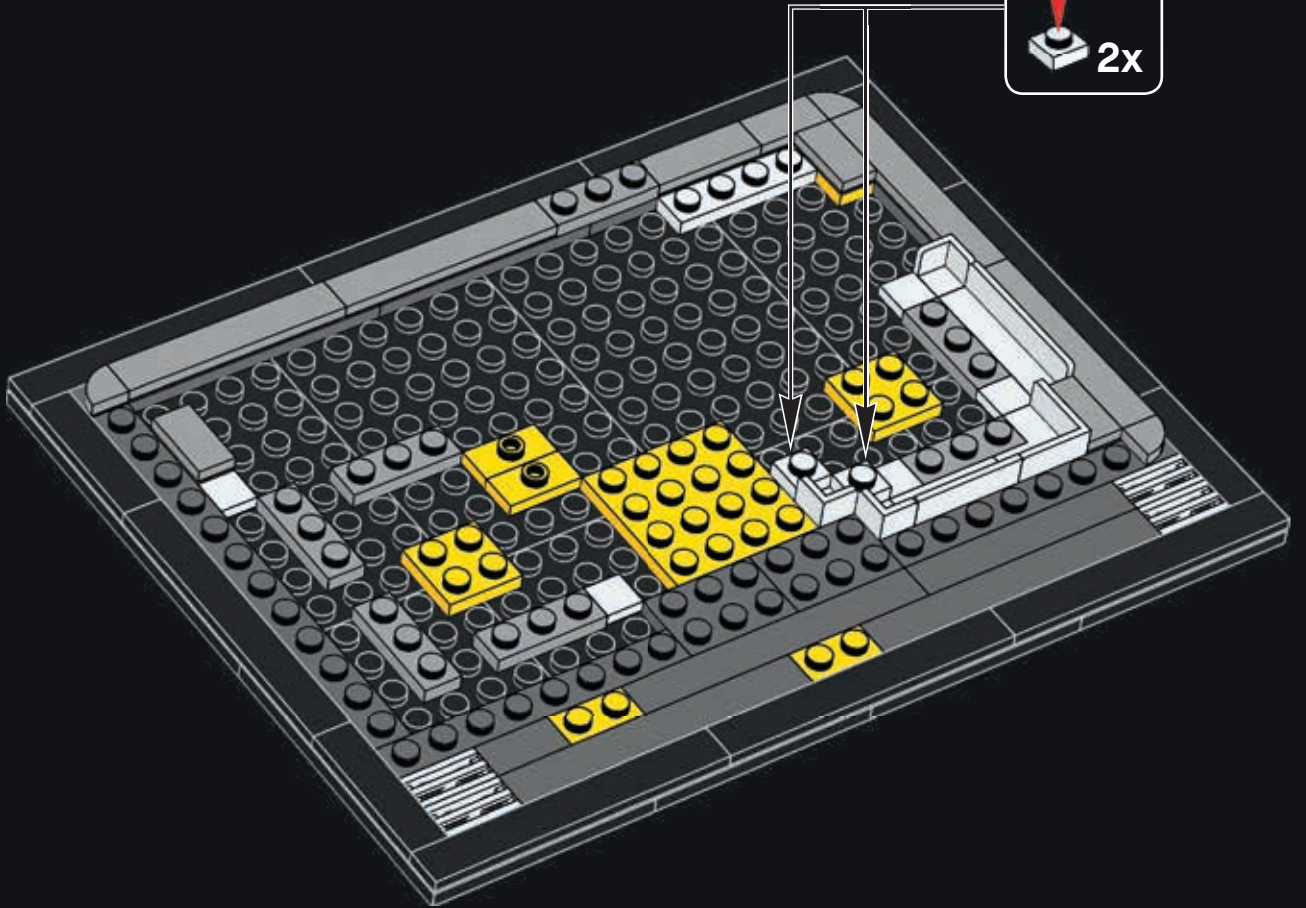



16

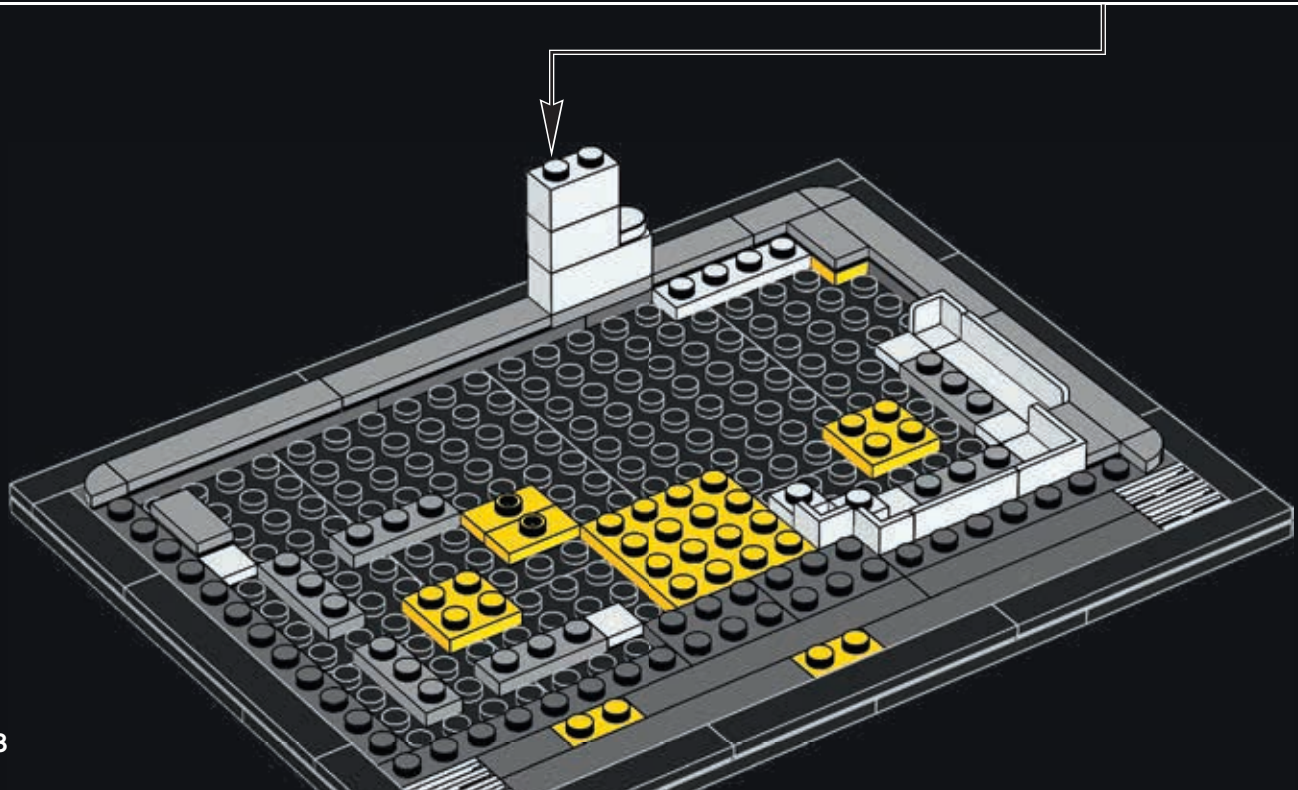

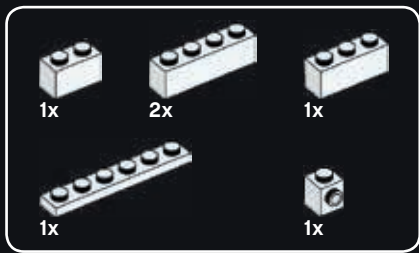

17

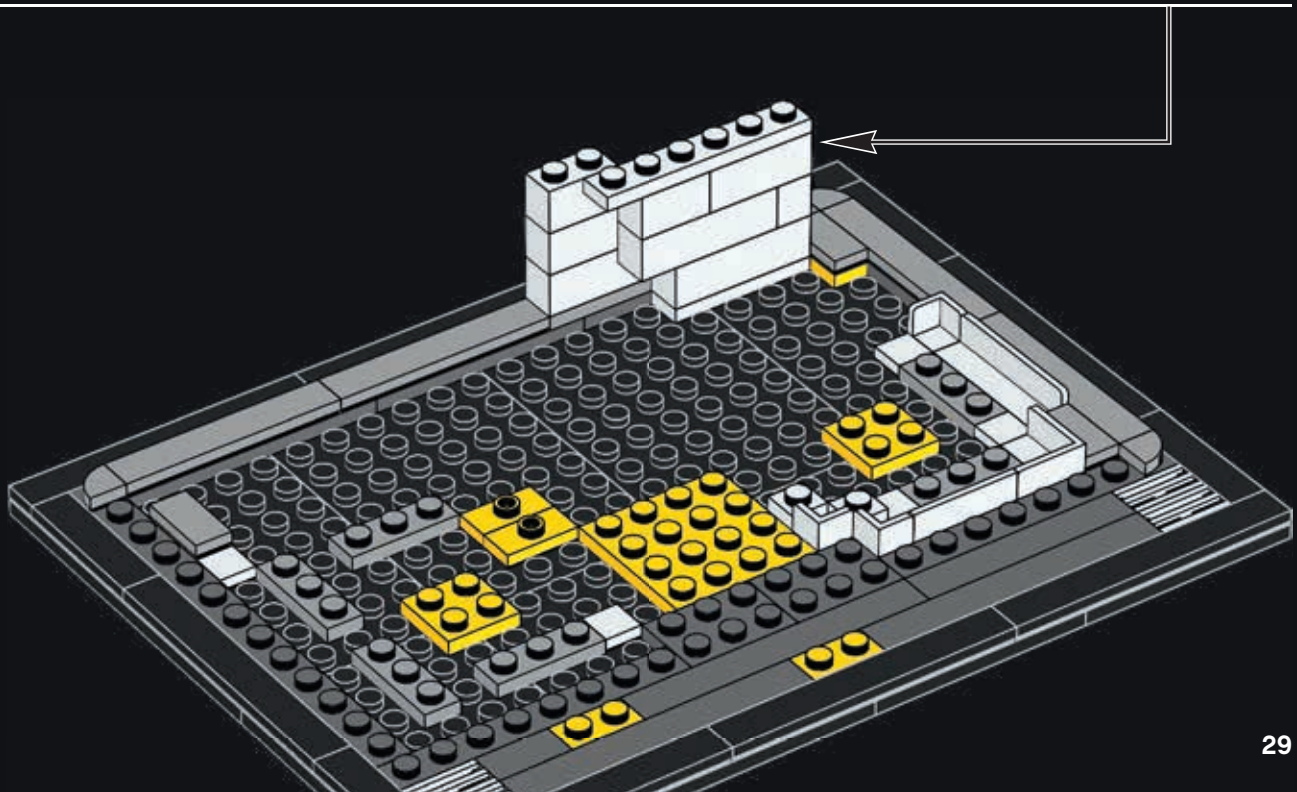
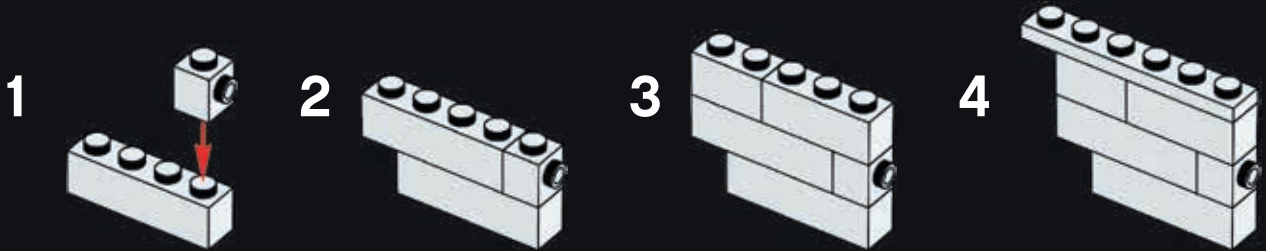



19

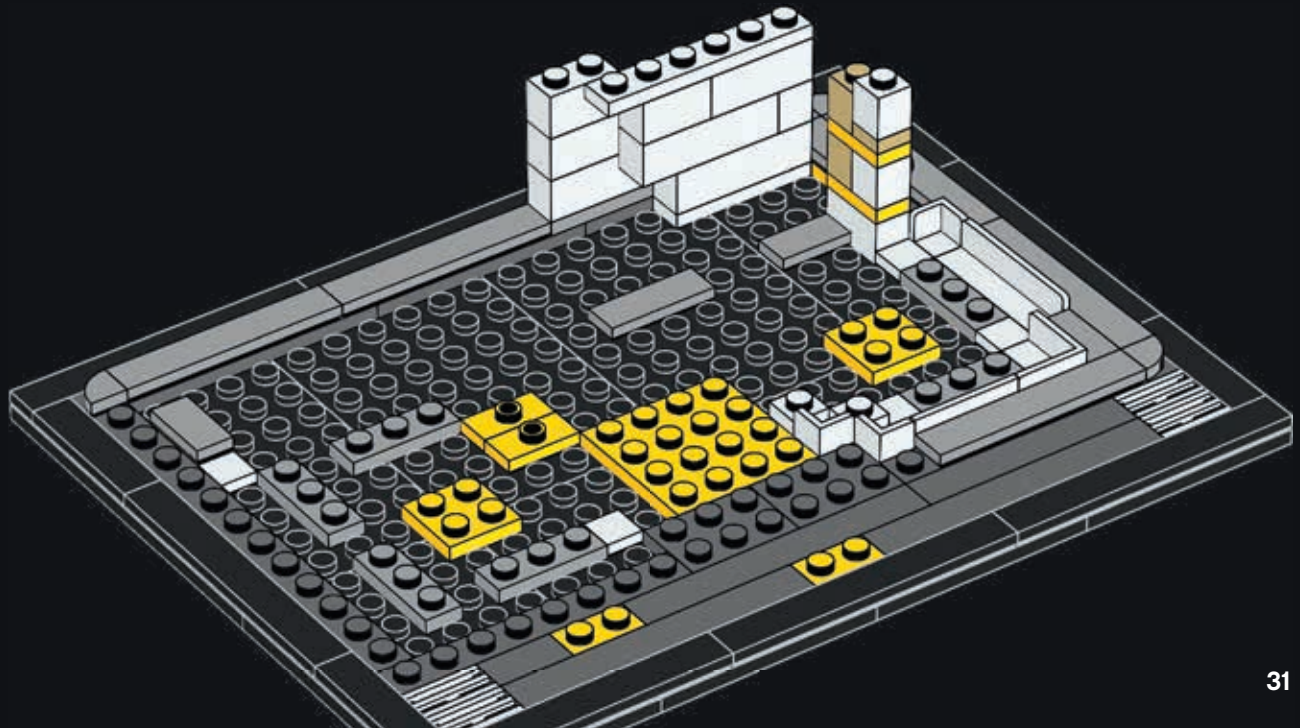



20

1

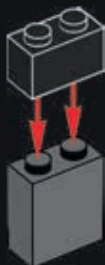

2



3

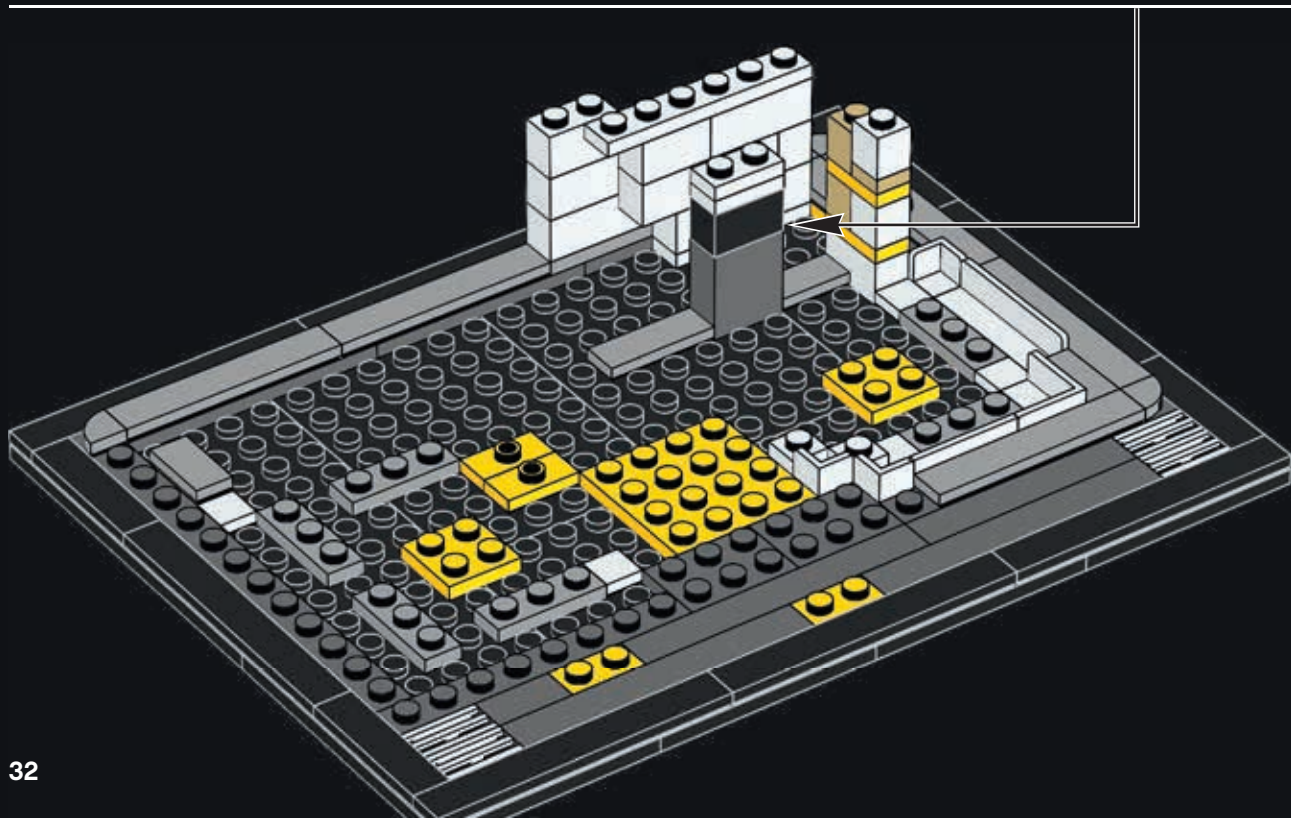

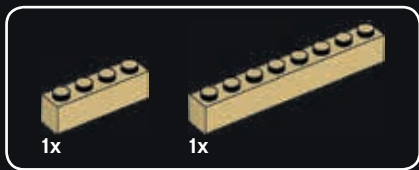

21

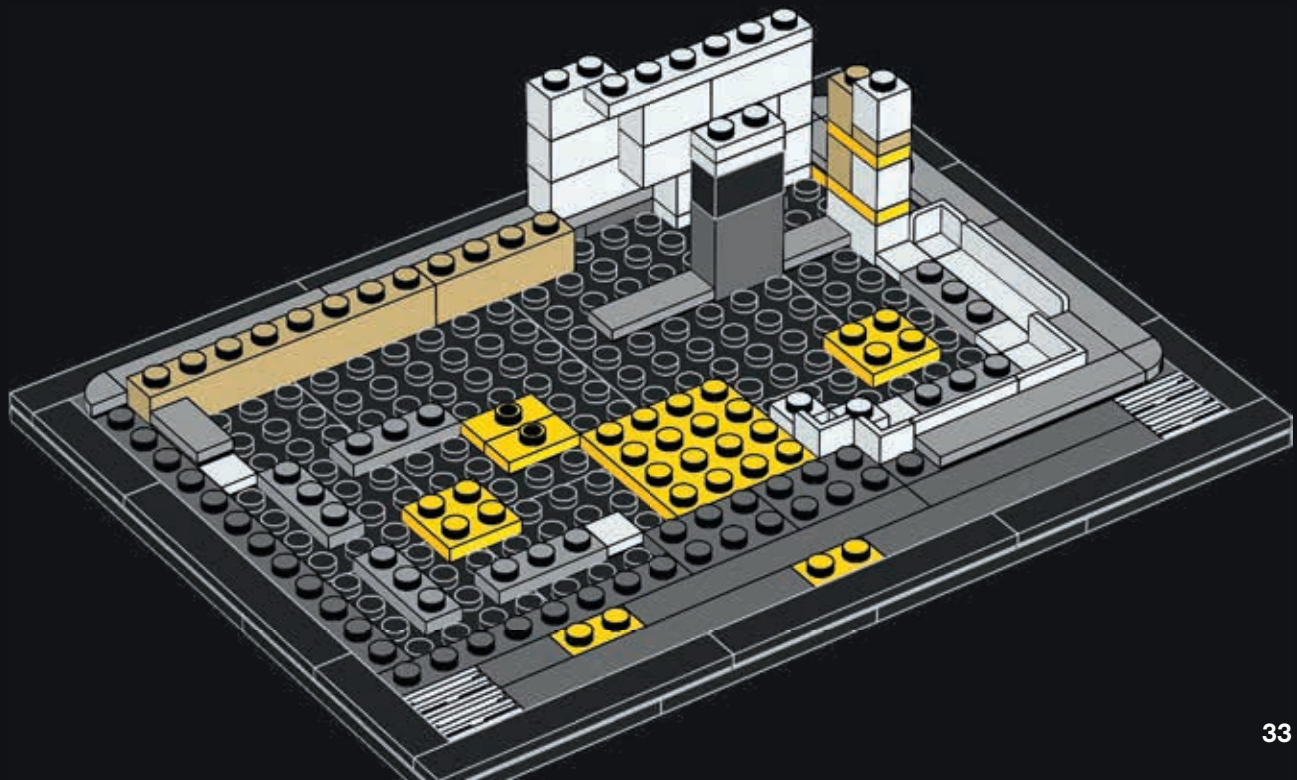

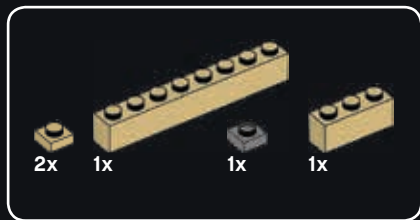

22

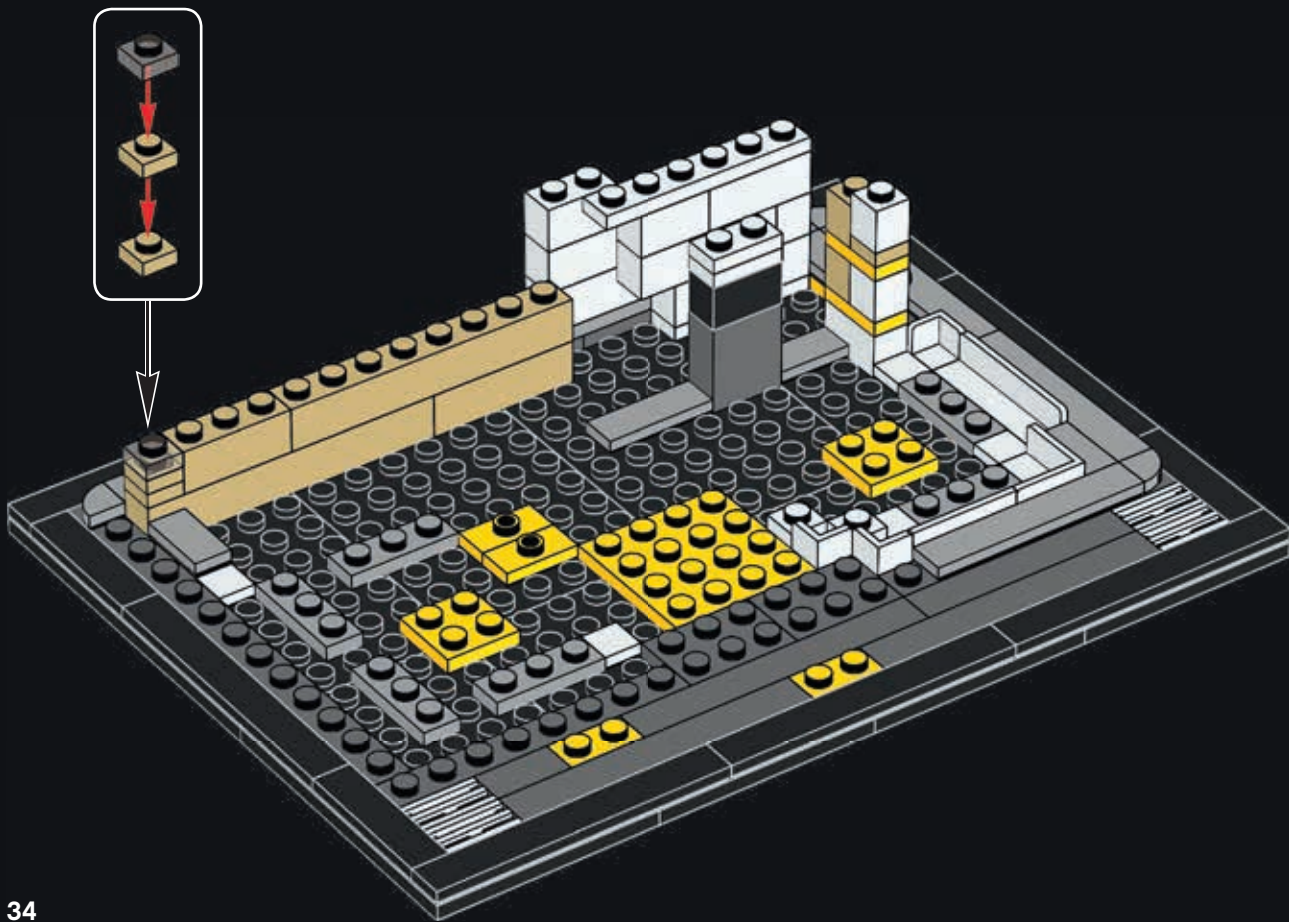



23

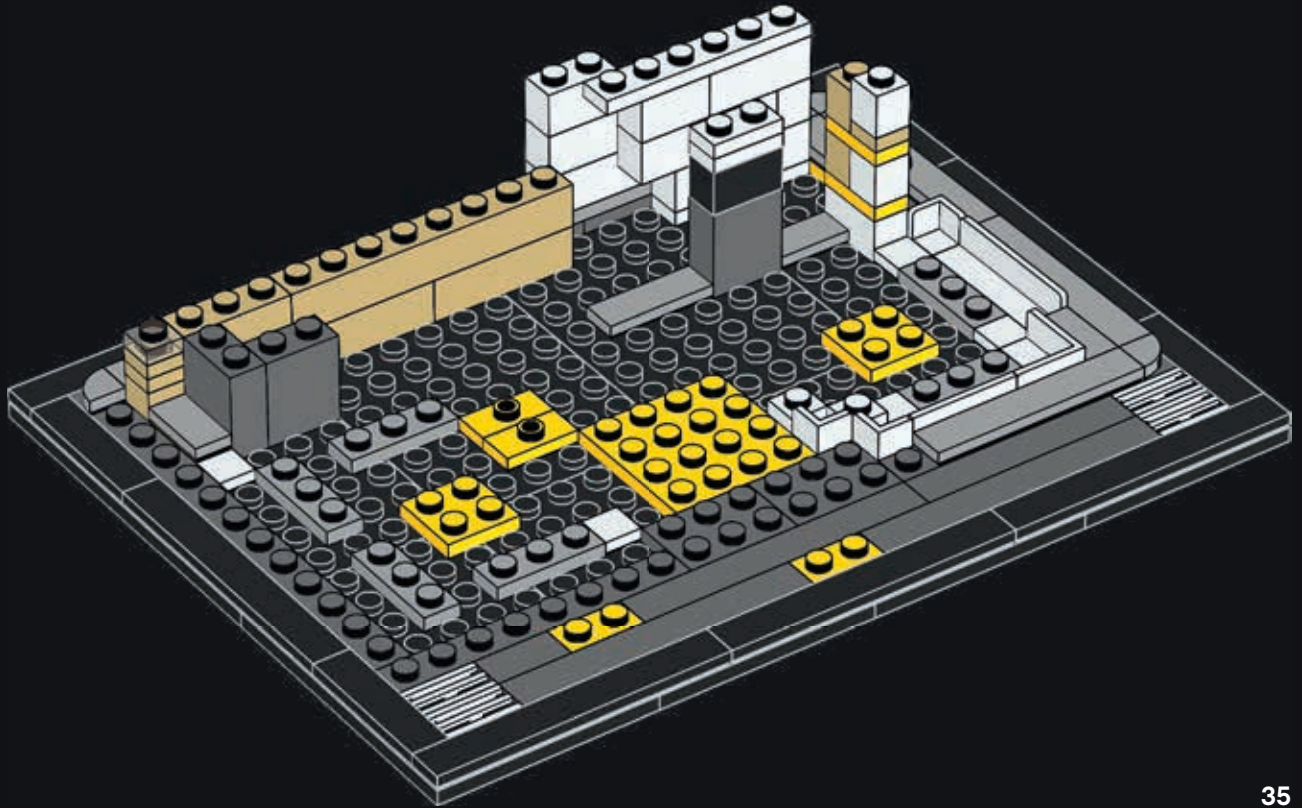



26

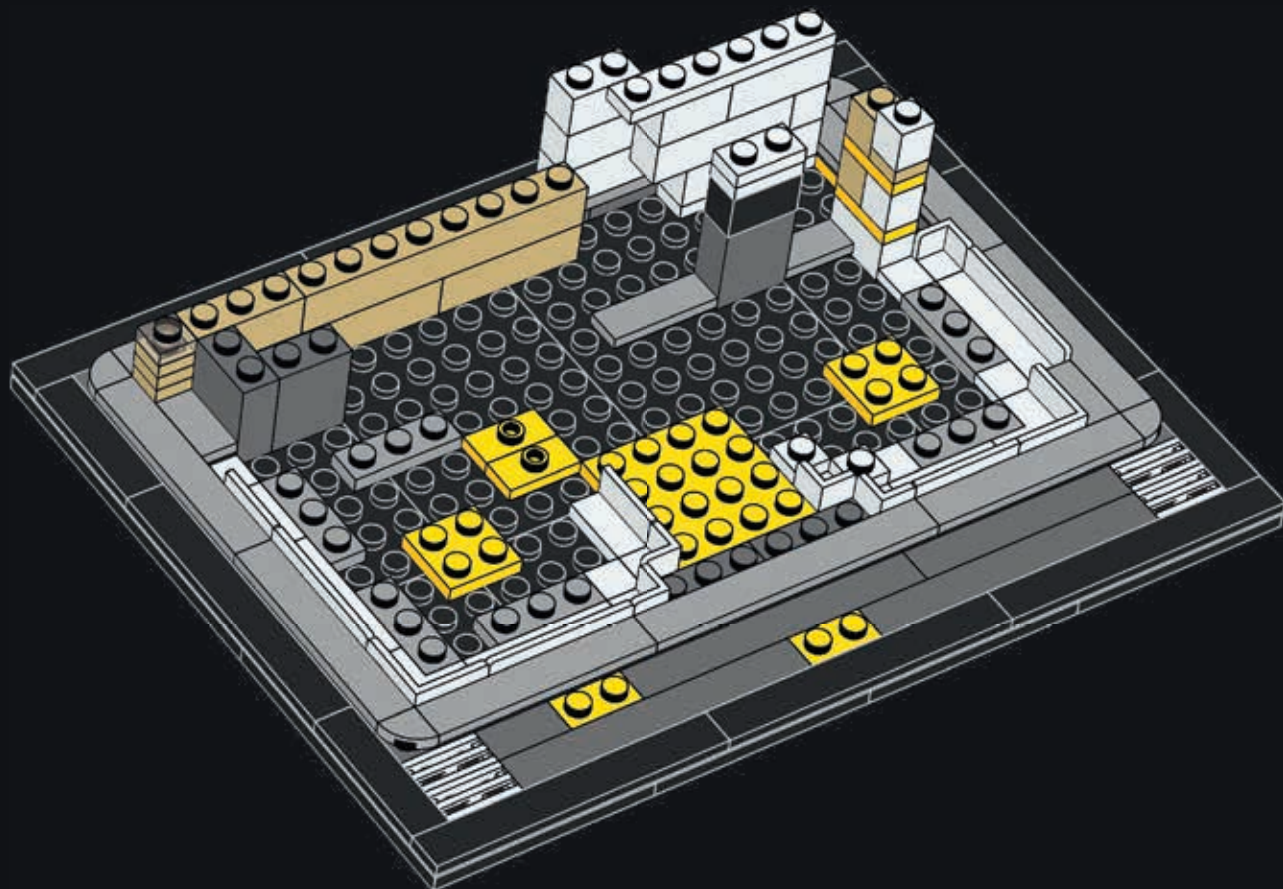

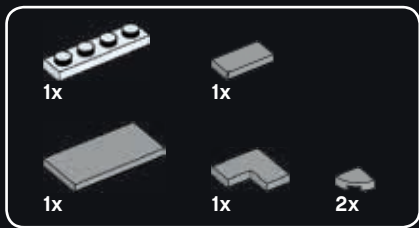

27

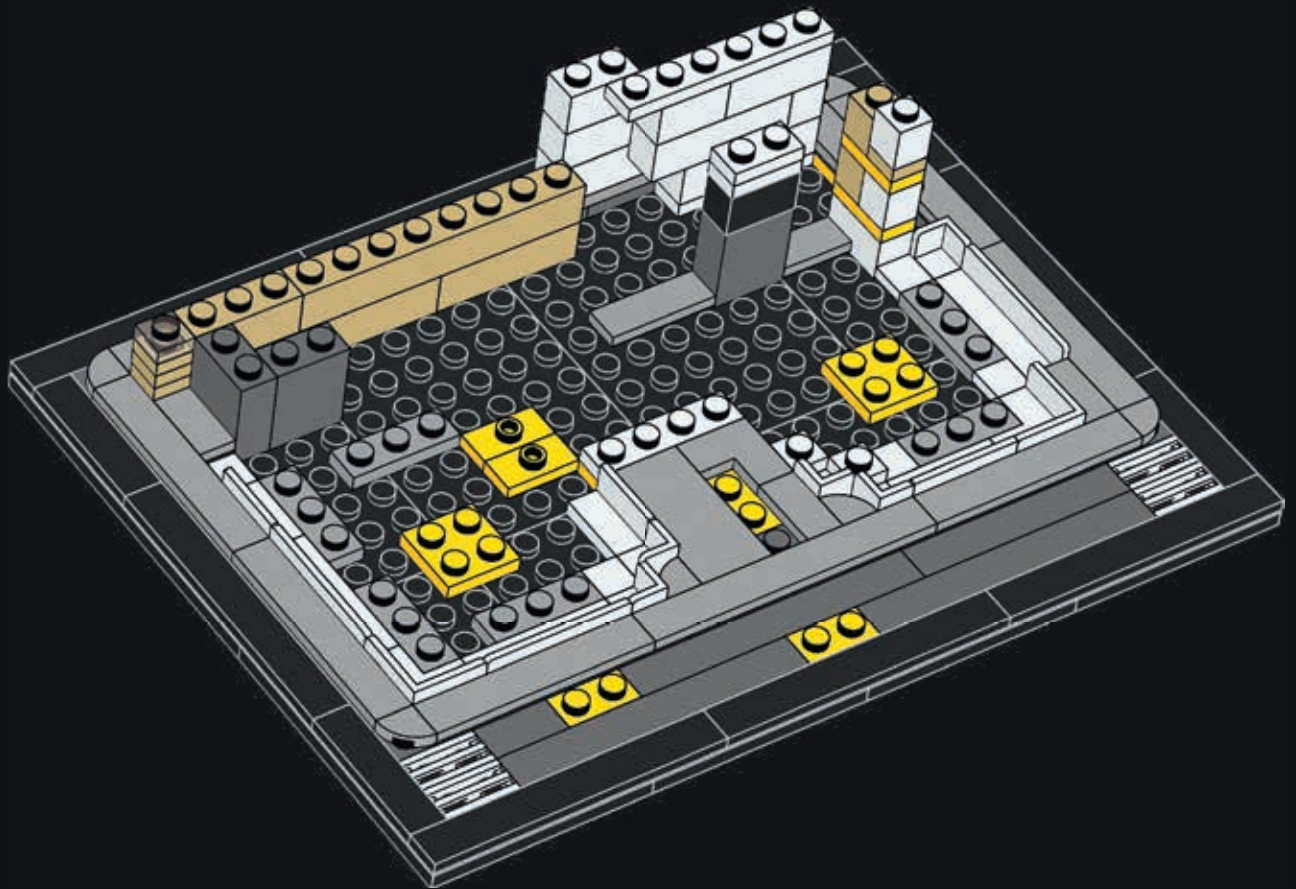



1x



2x

28

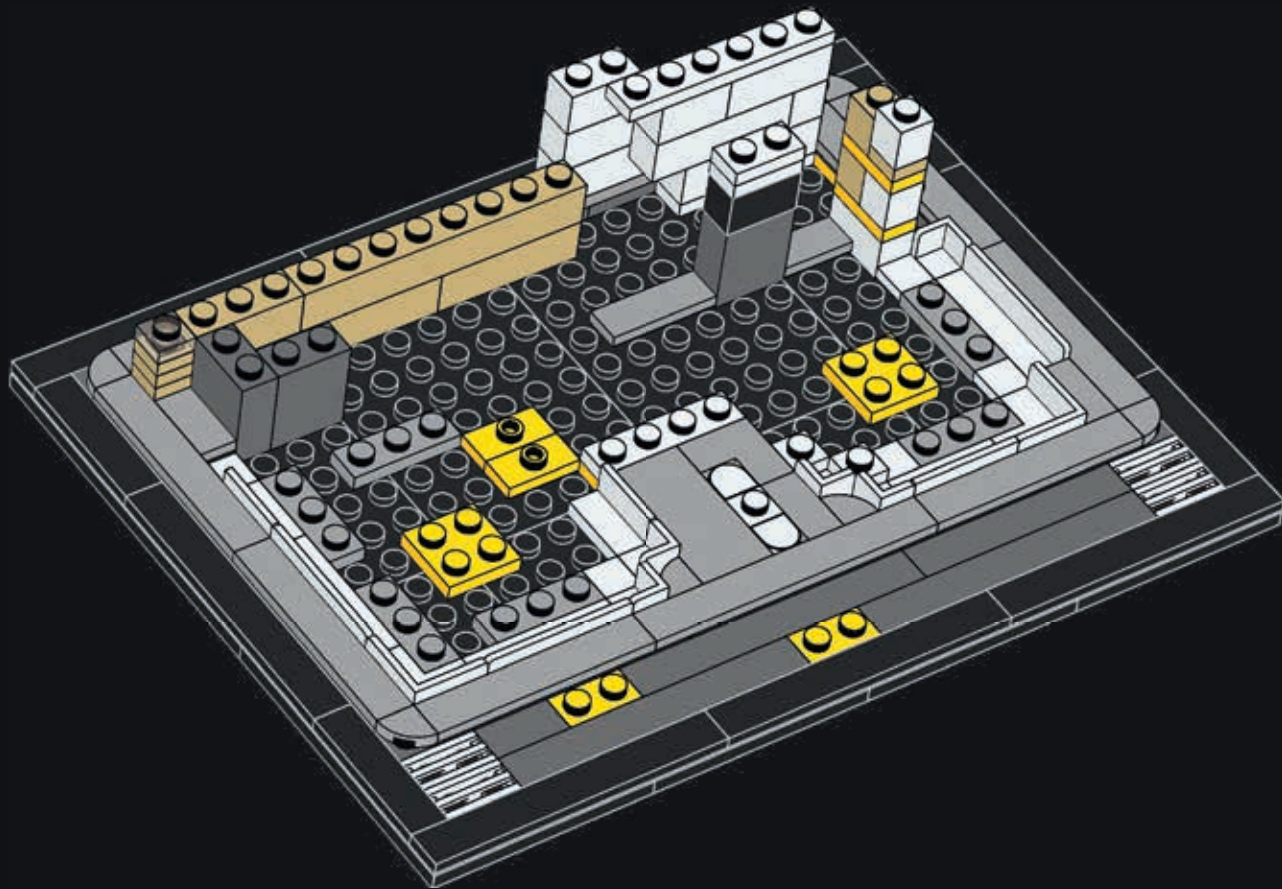



2x

29

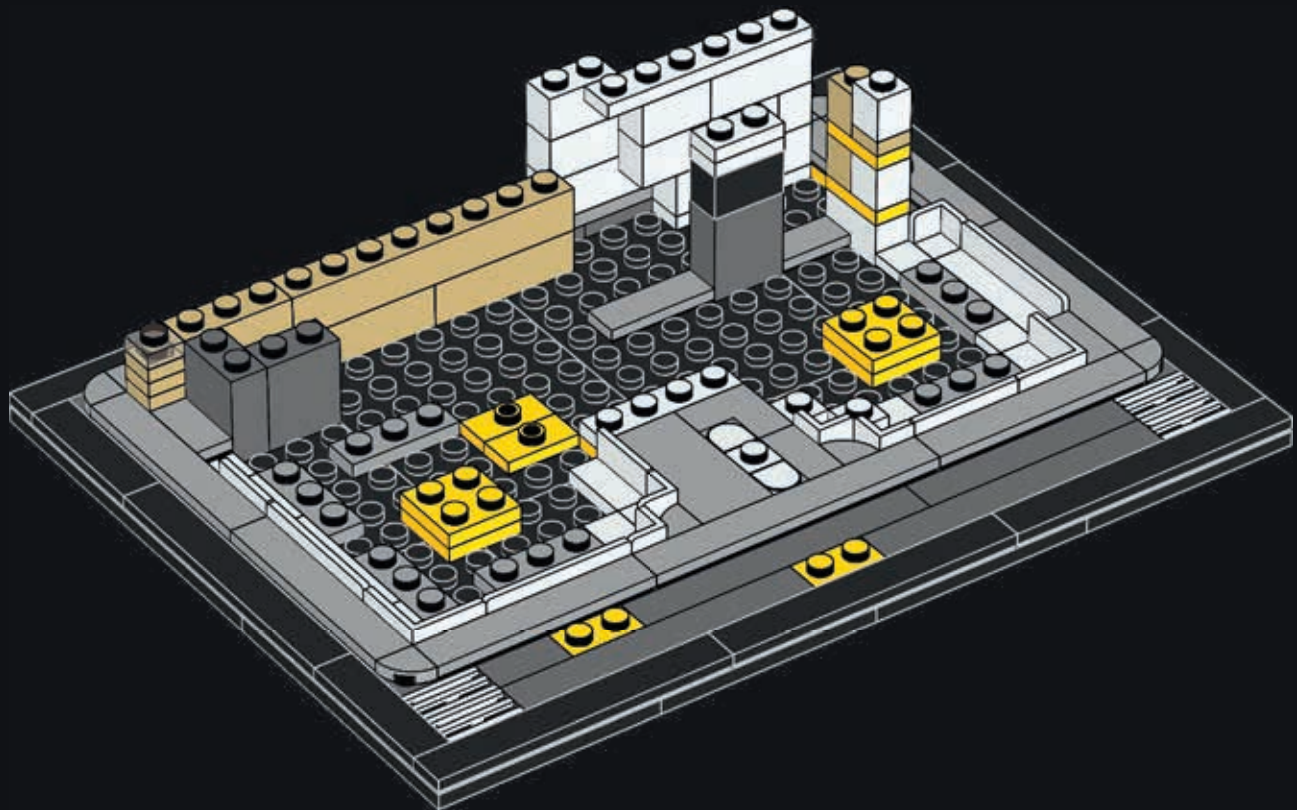



30

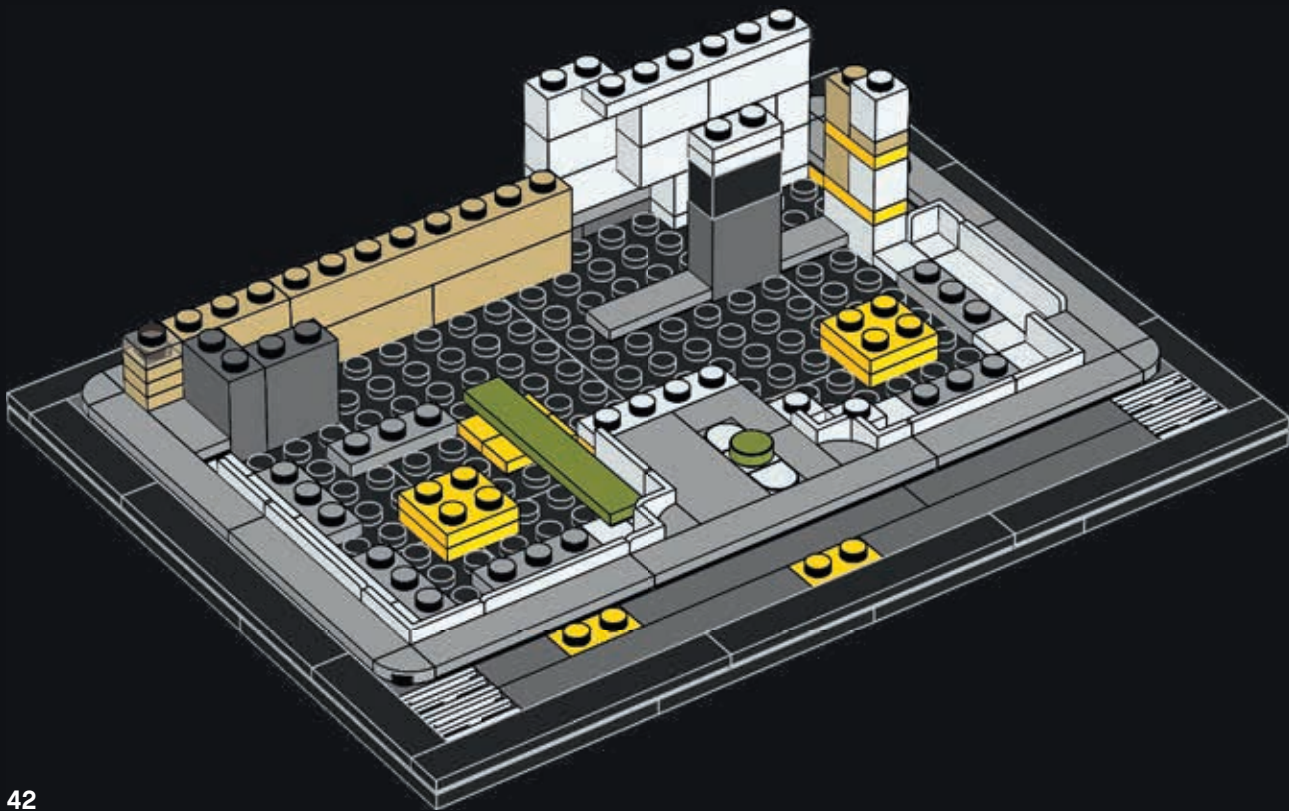



31

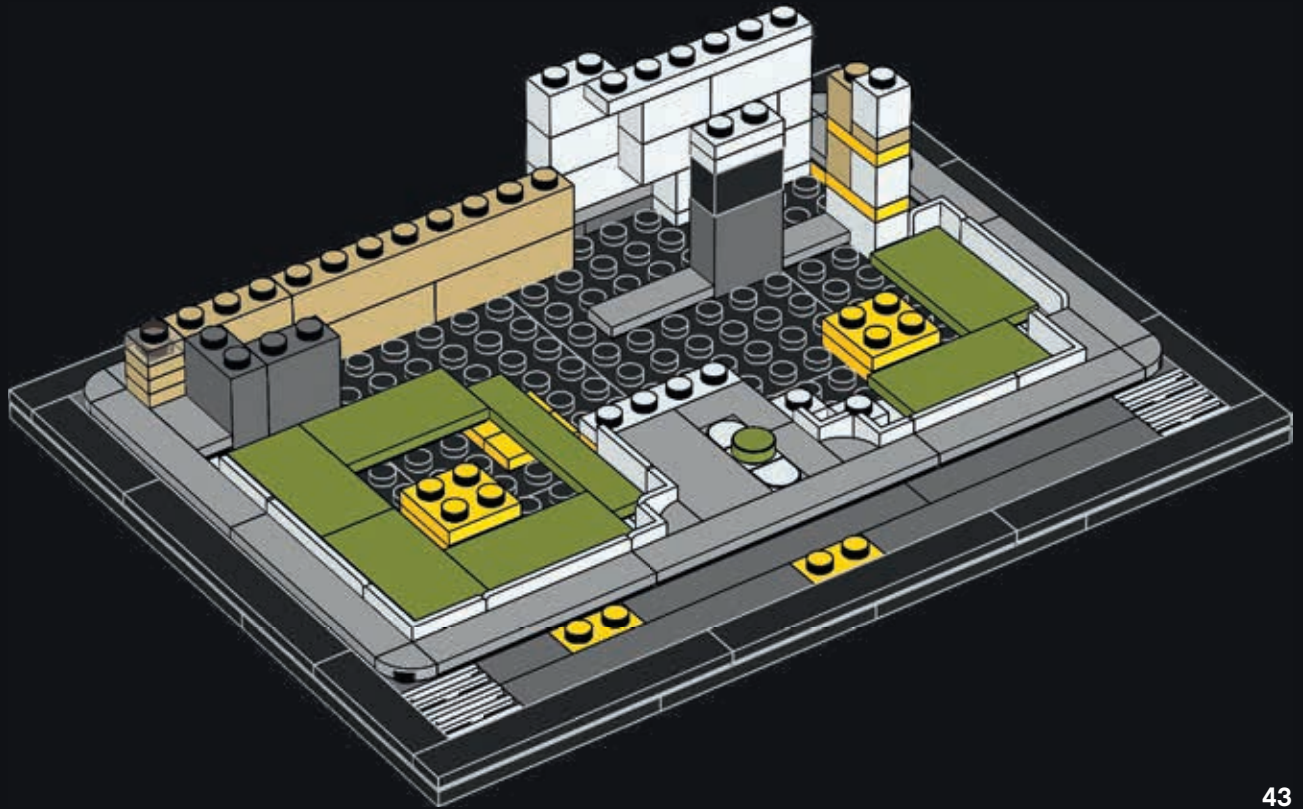

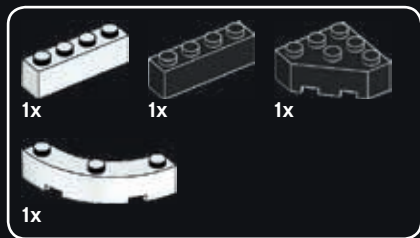

32

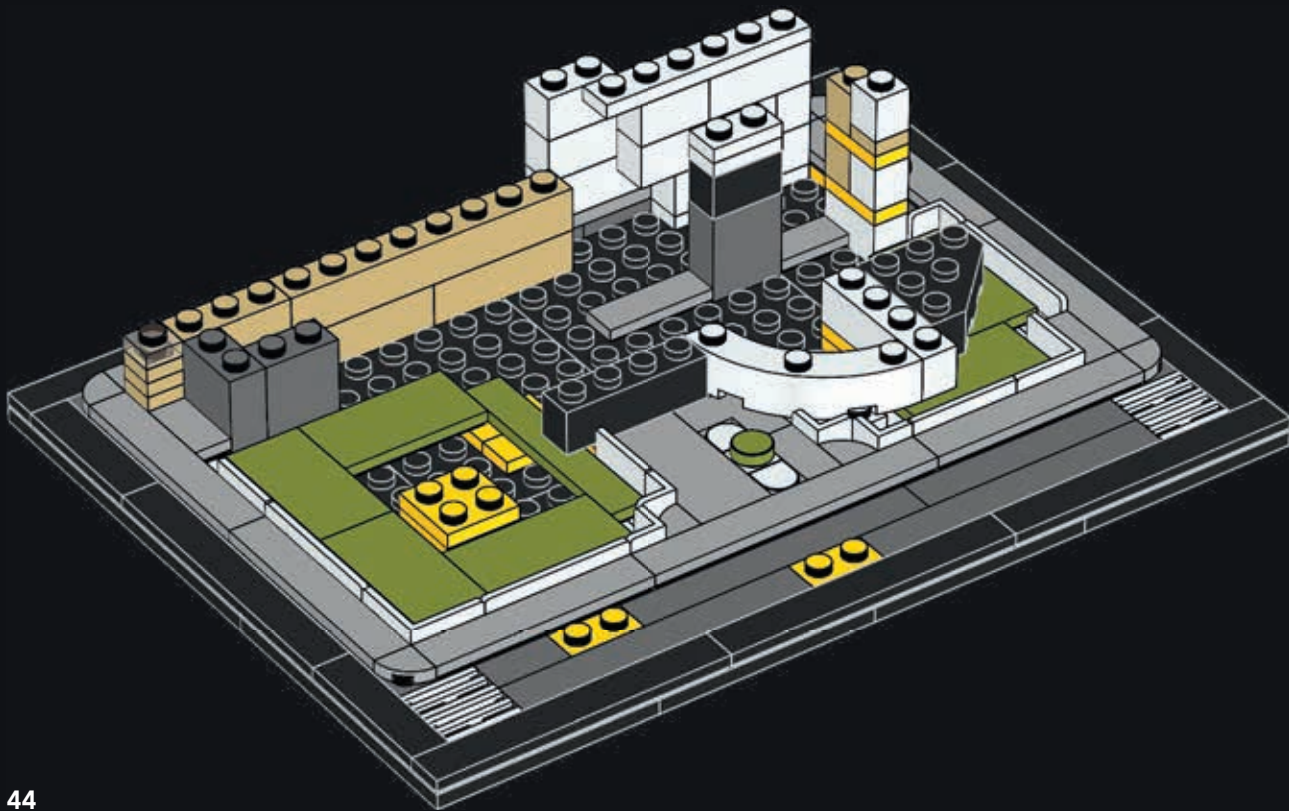



3x

33

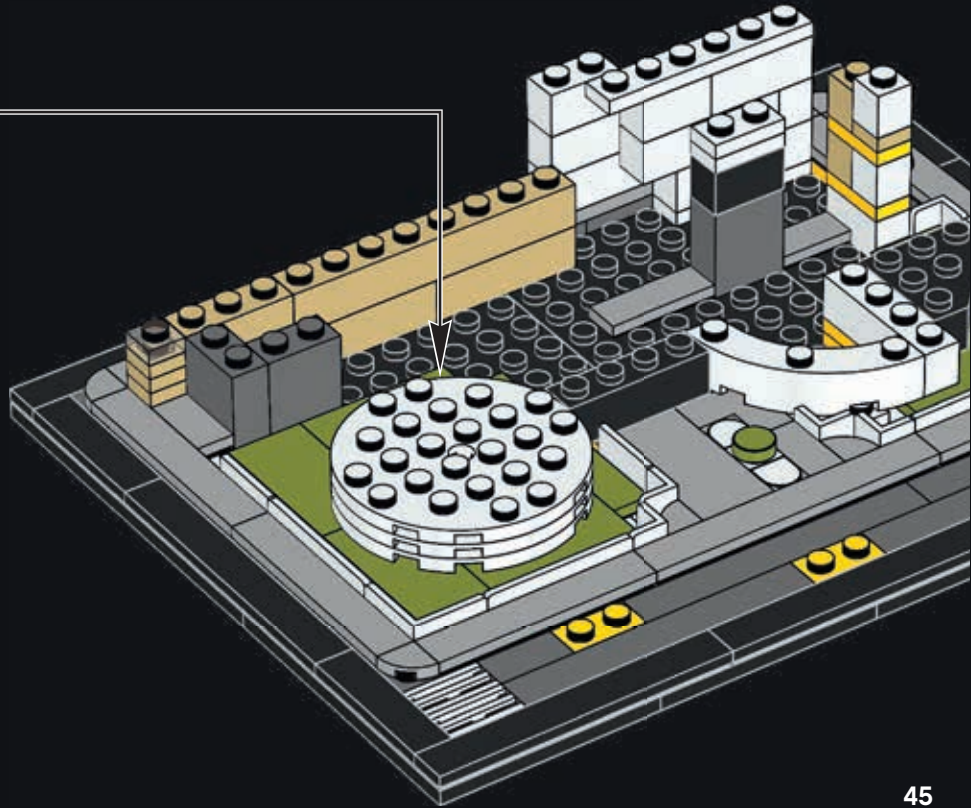
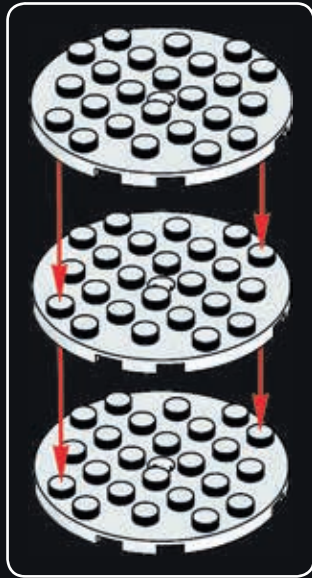

Frank Lloyd Wright originally wanted to call the Guggenheim the "Archeseum," which means "to see from the highest."



©The Solomon R. Guggenheim Foundation, New York



34

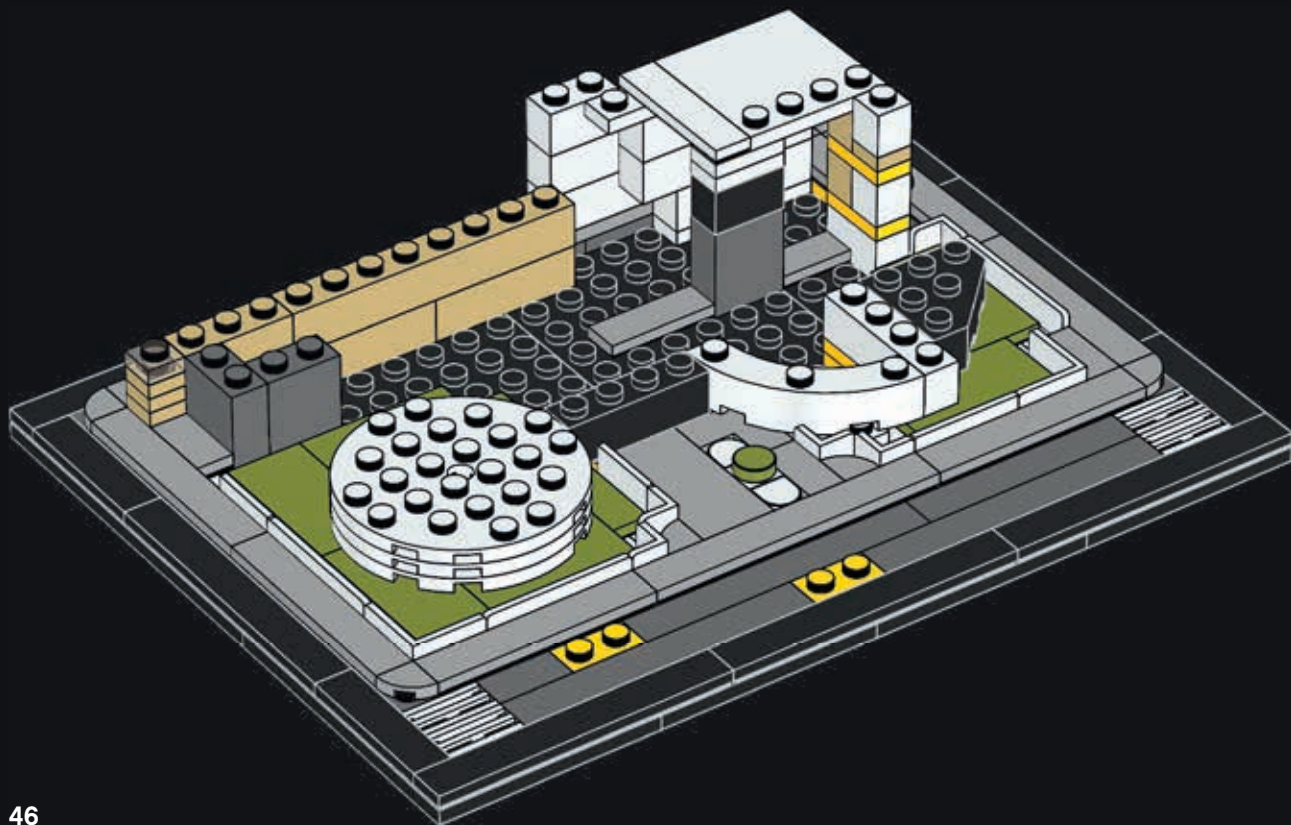



1x



1x

35

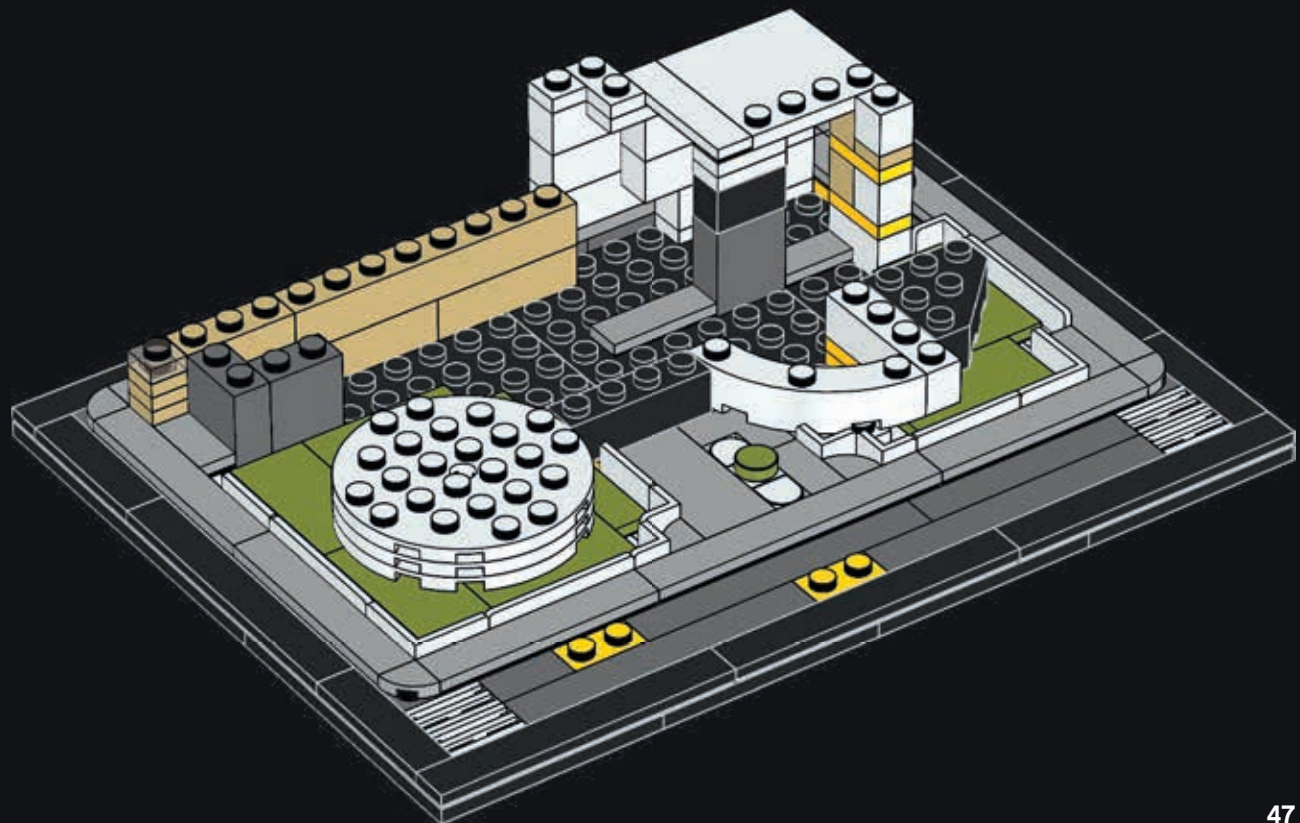

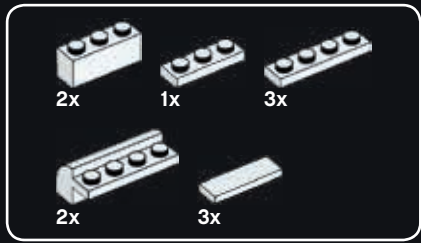

36

1

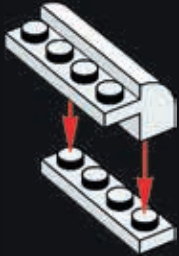

2

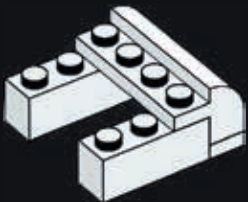

3

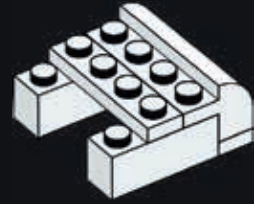

4

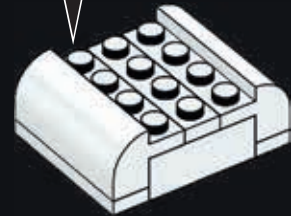
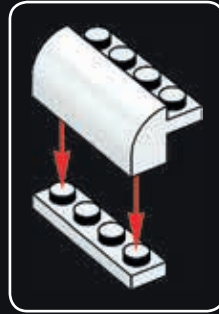

5

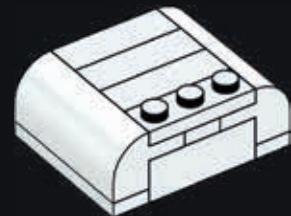

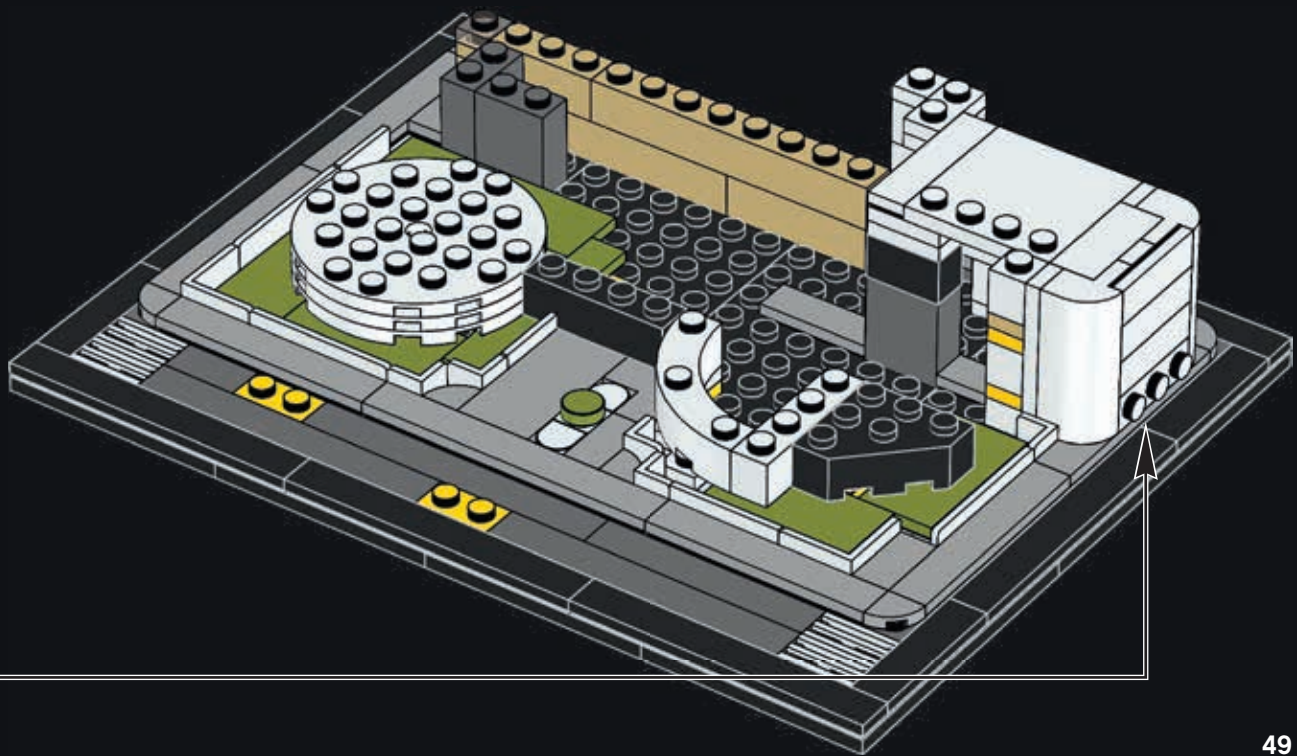

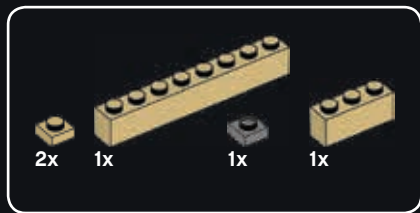

37

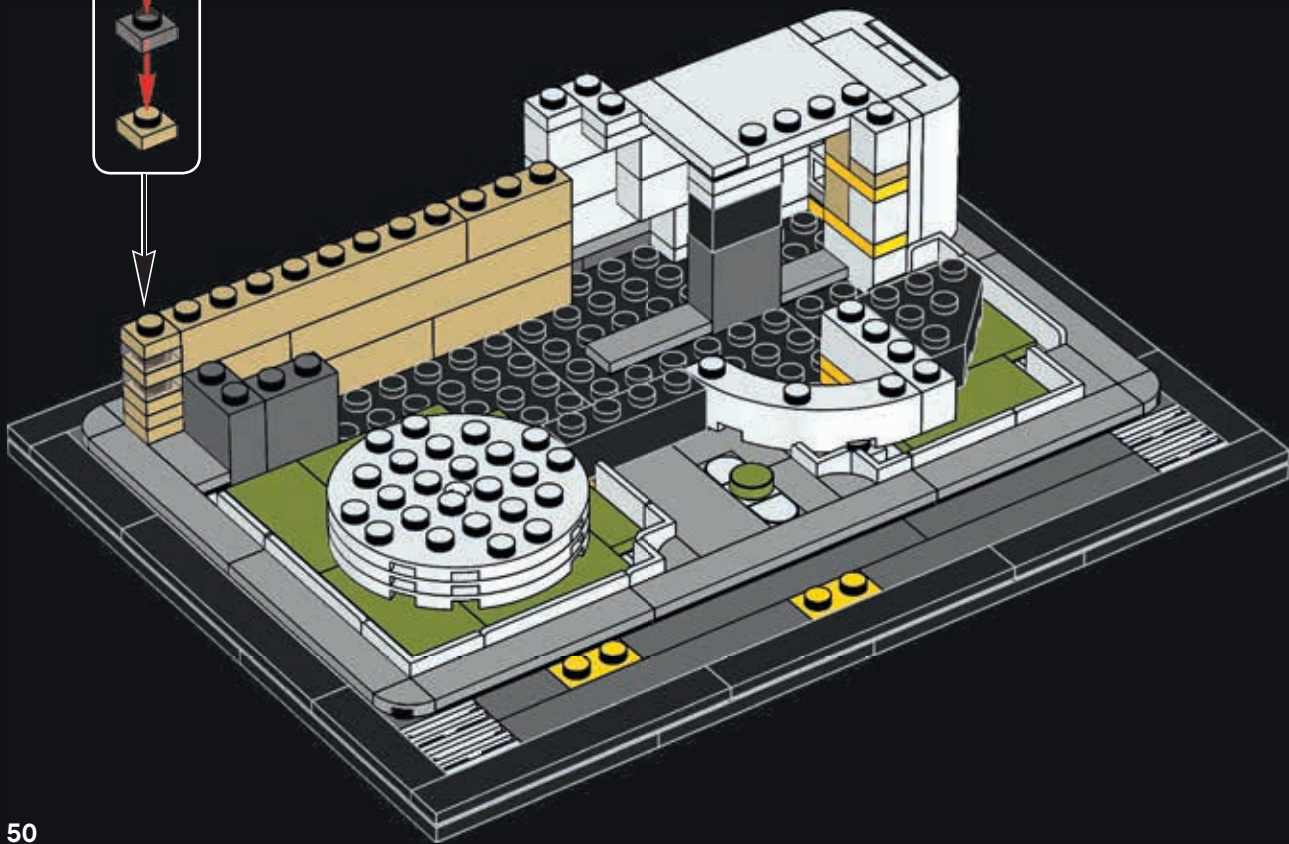
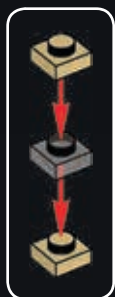



1x

38

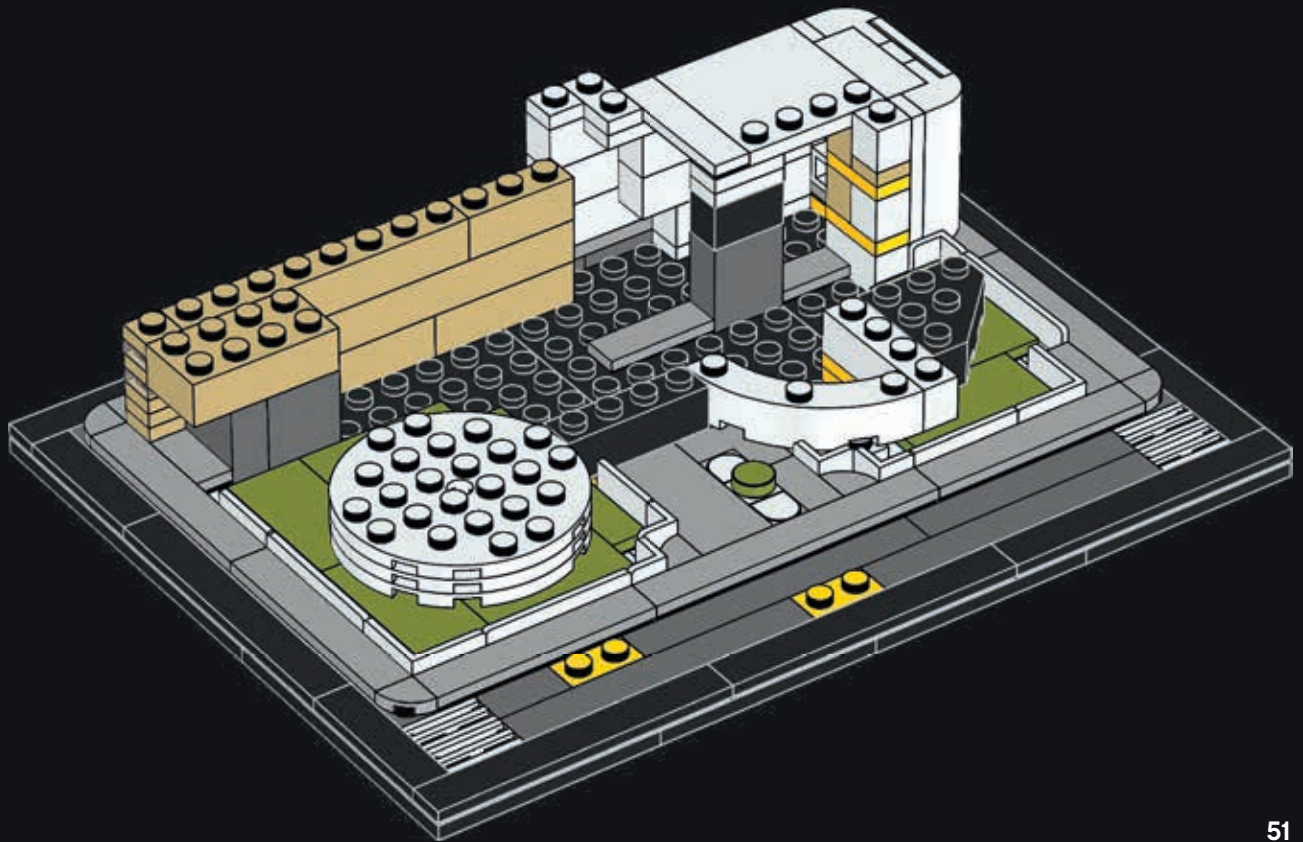

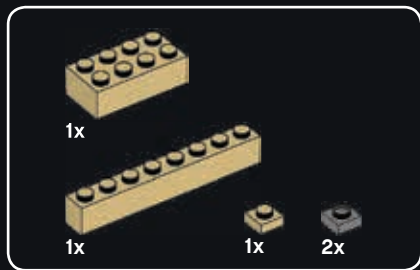

39

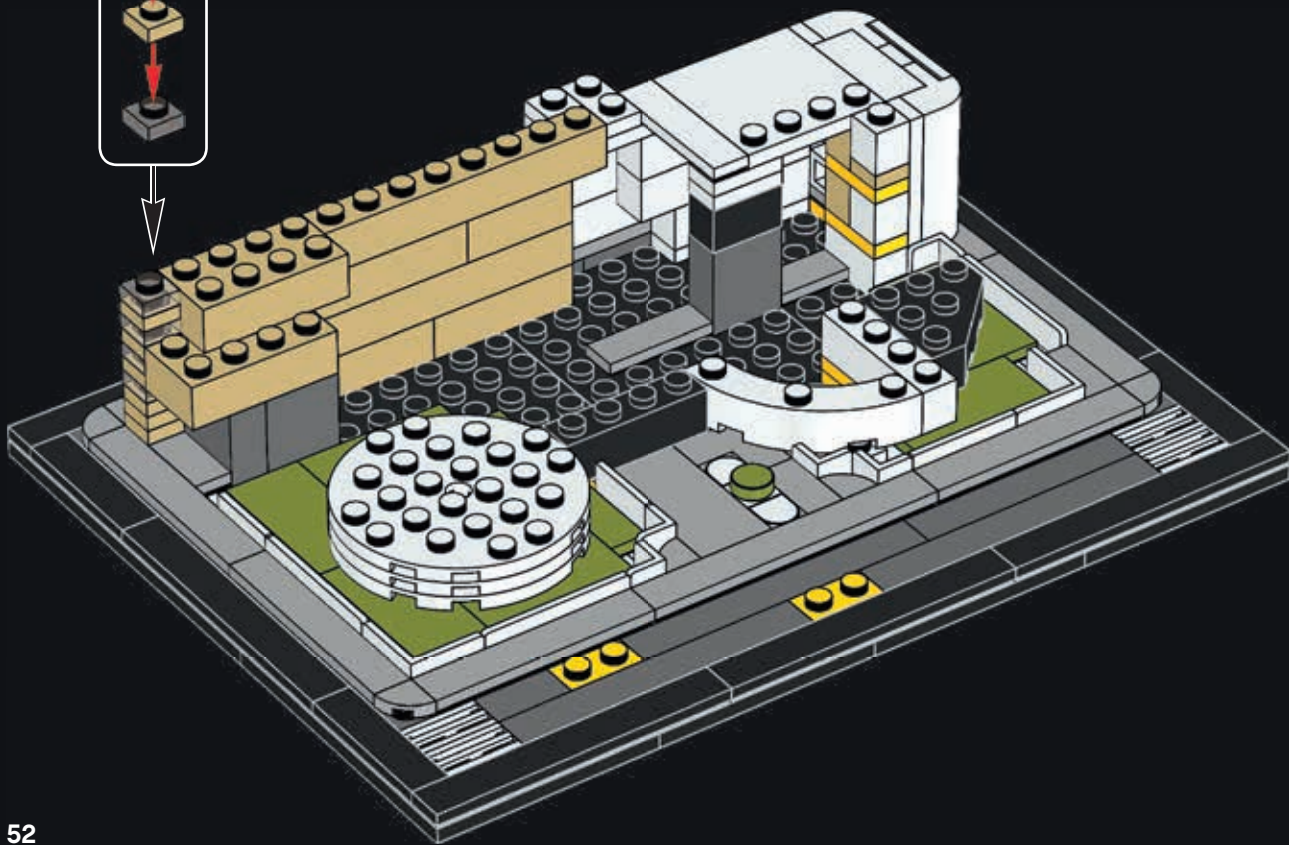



40

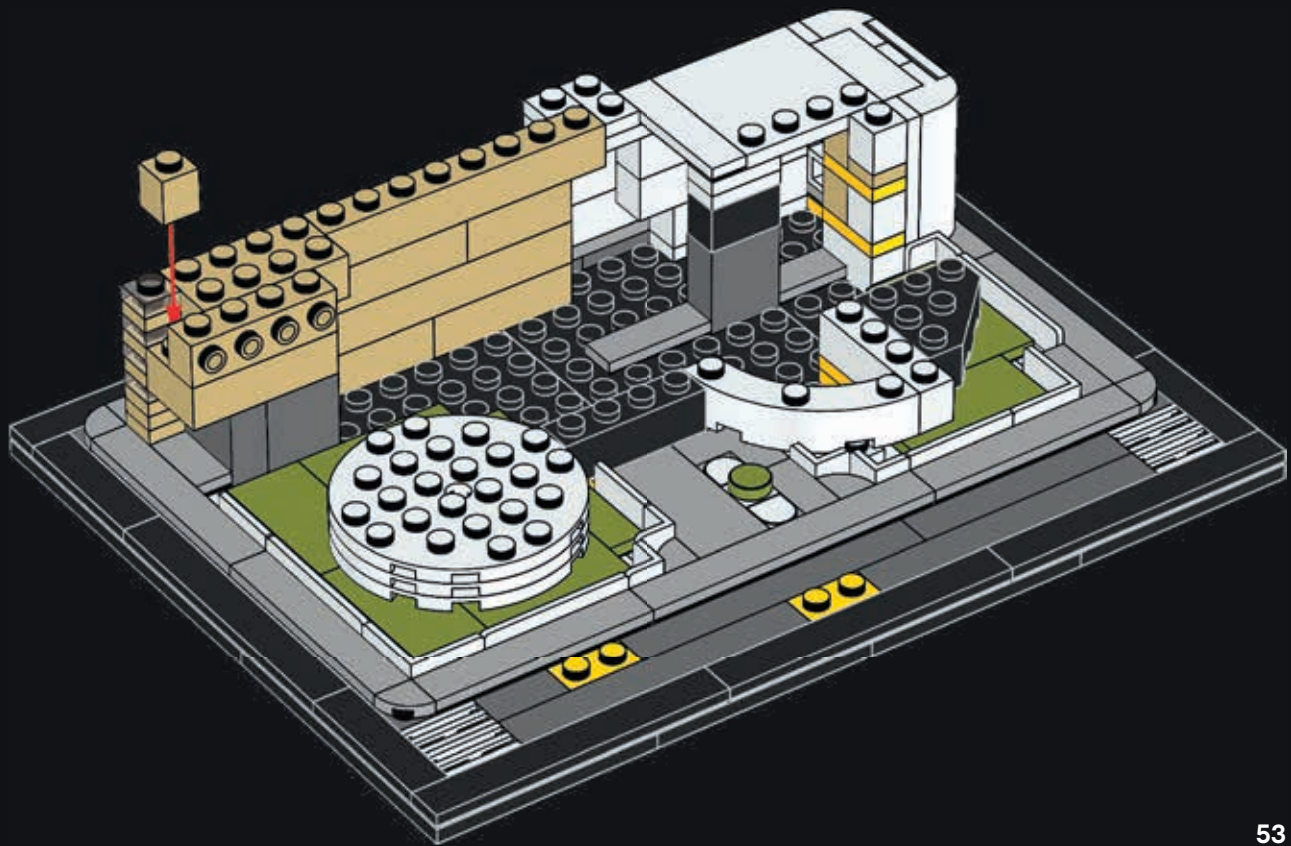

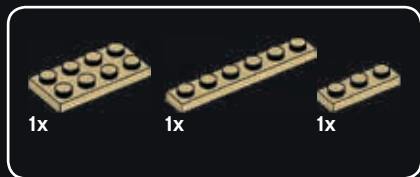

41

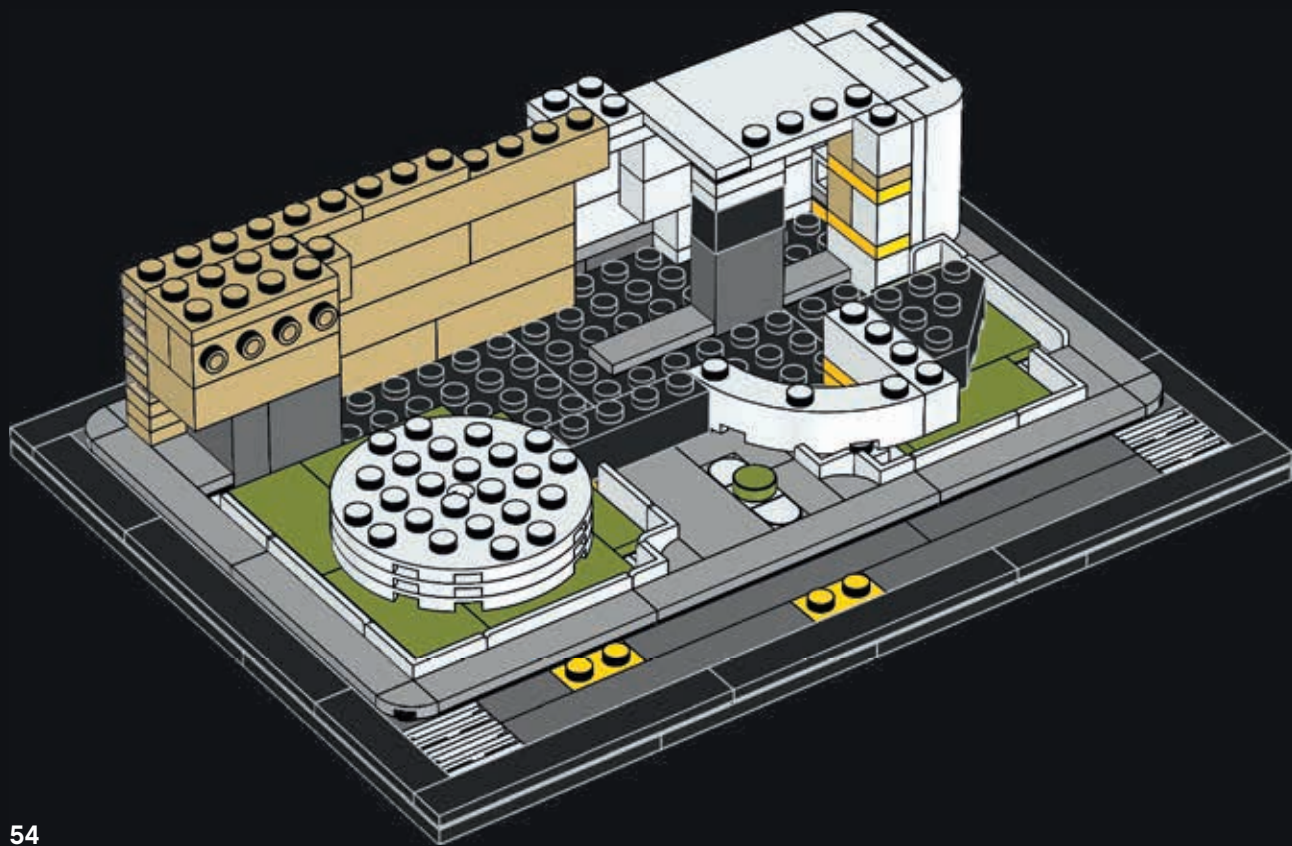



42

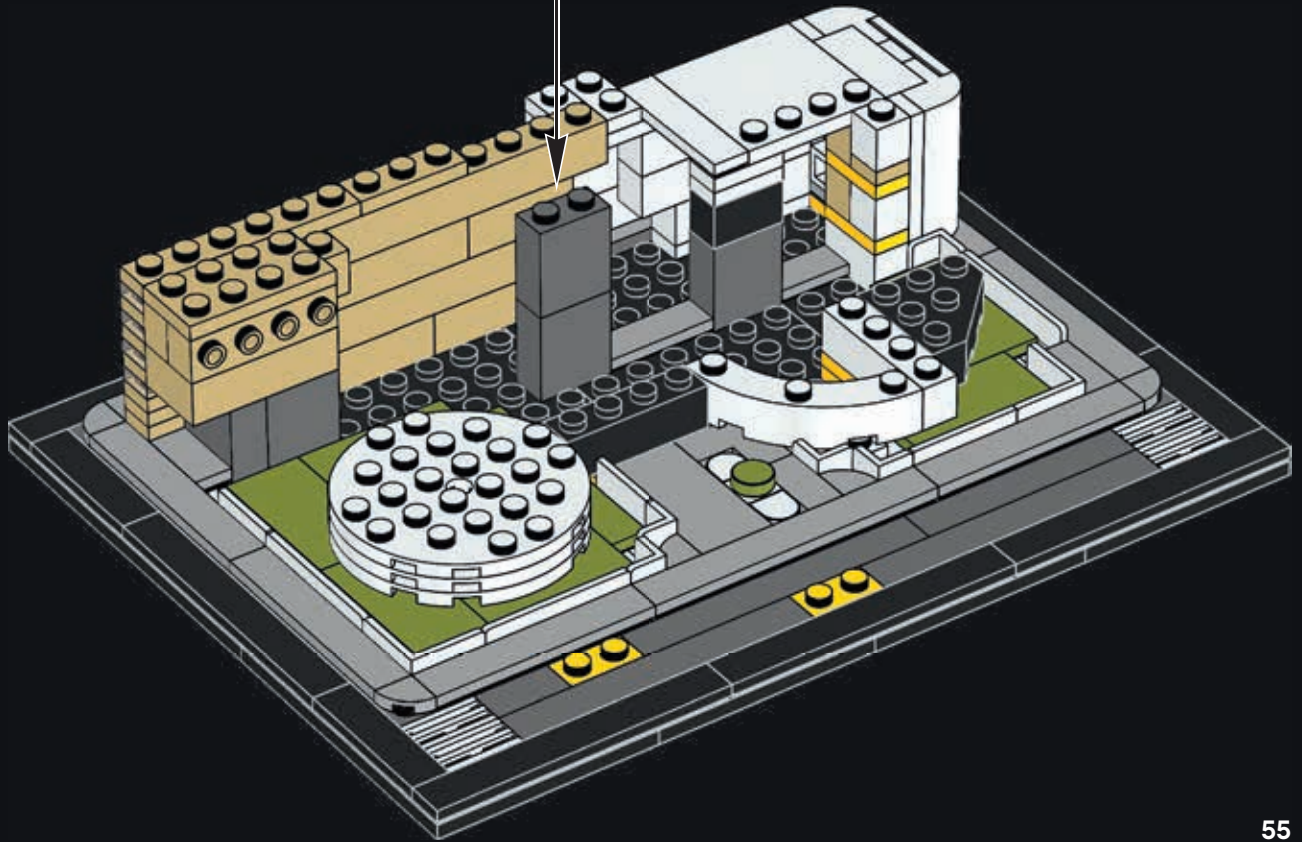
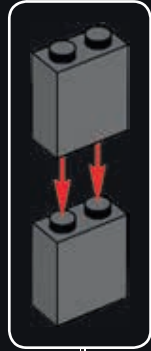



43

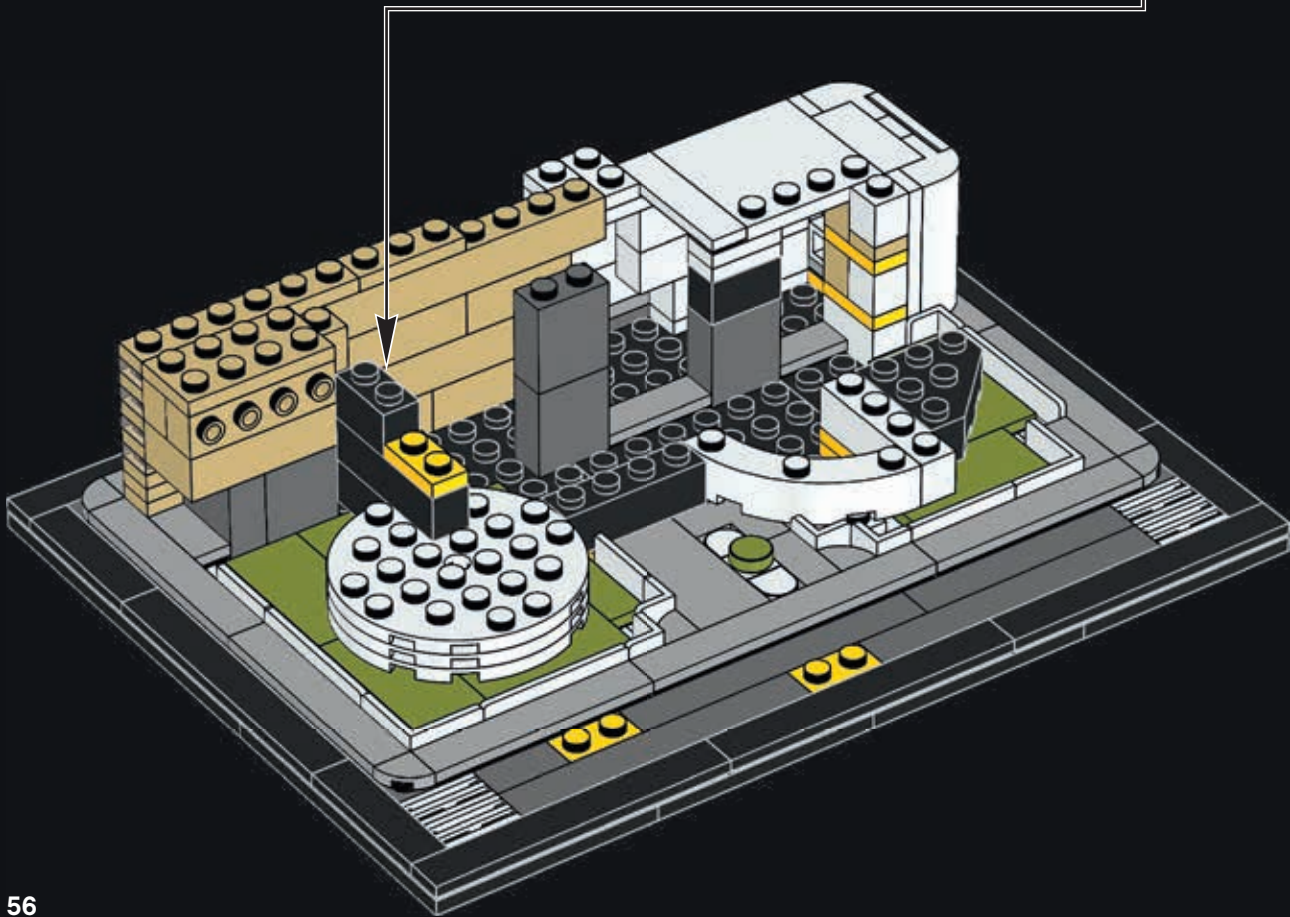
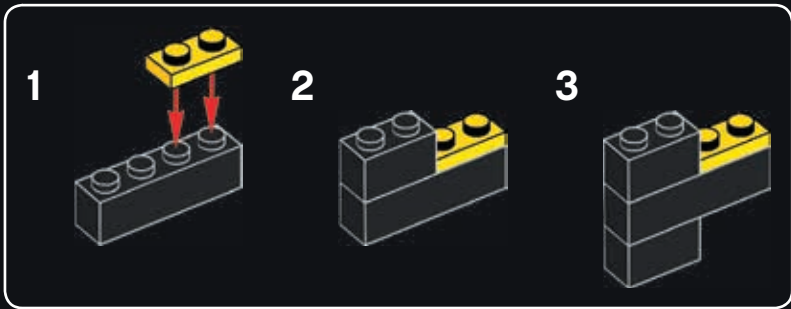

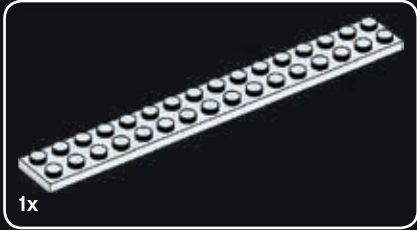
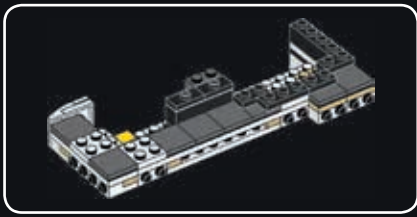

44



45





1x

46



1x

2x

47





48

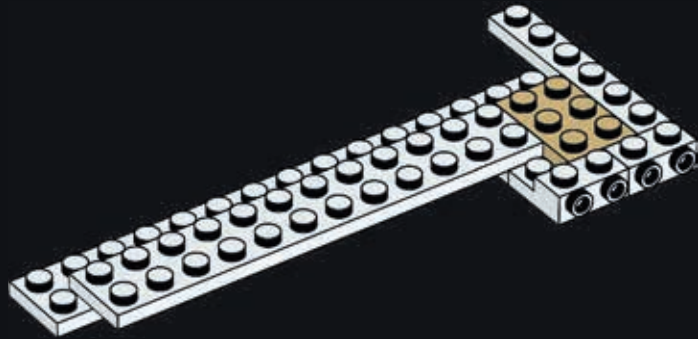

49

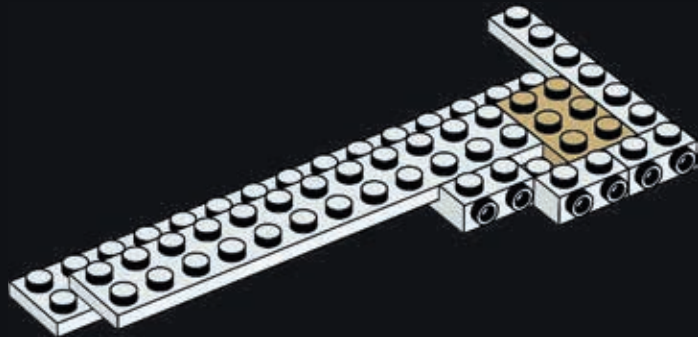



50

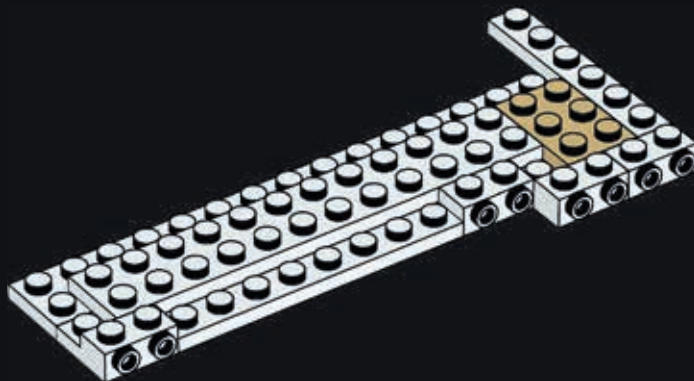

51

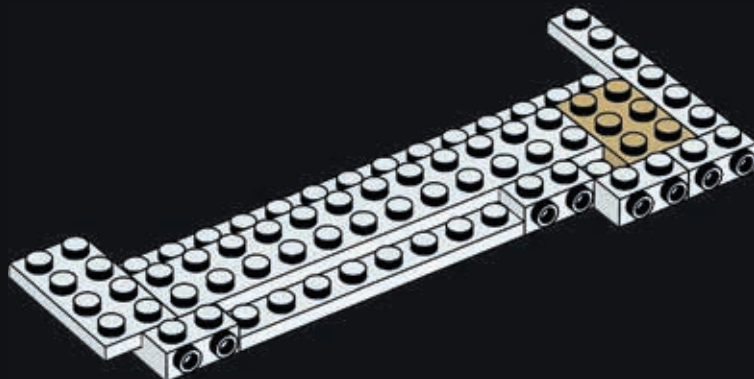



2x

52

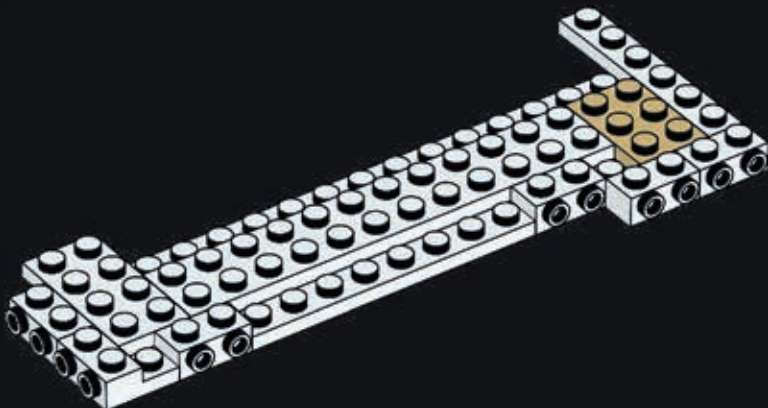

1x

53

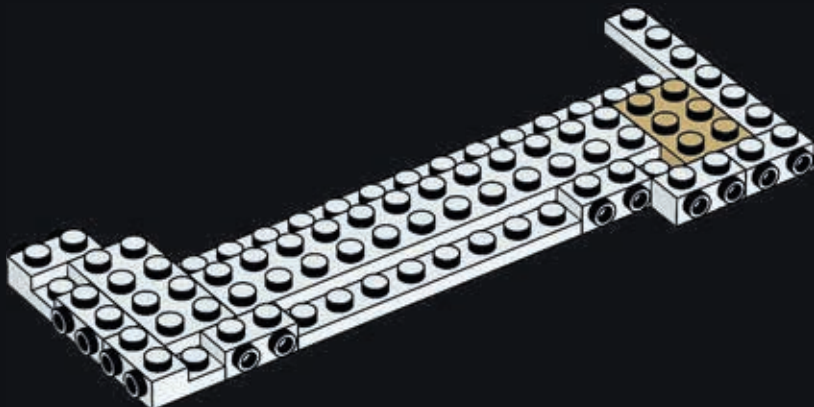



1x



5x

54

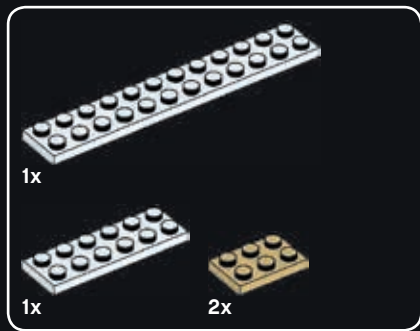
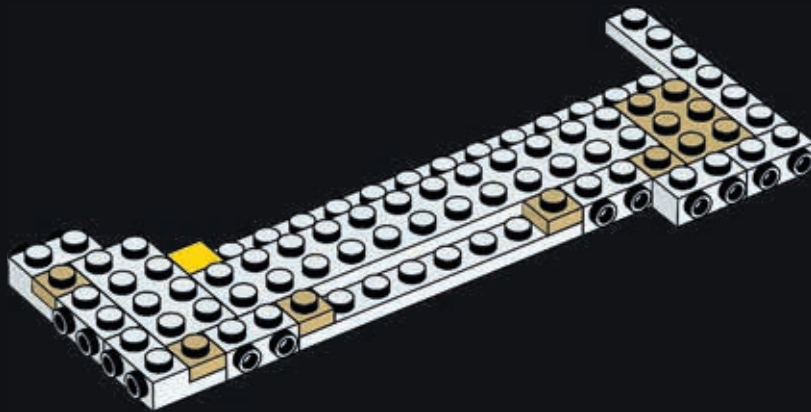

1x

1x

2x

55

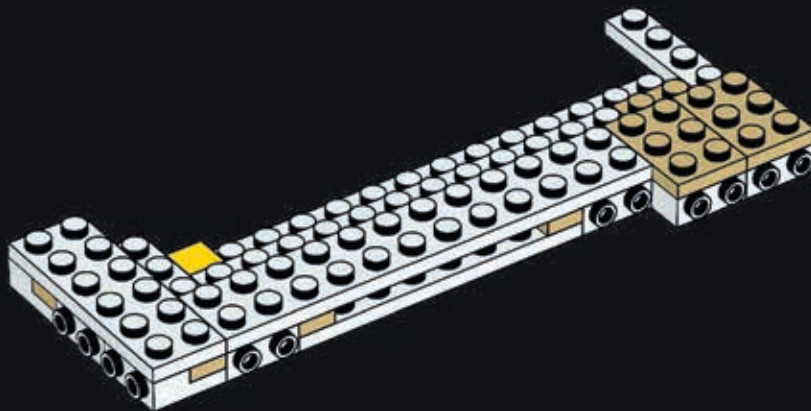

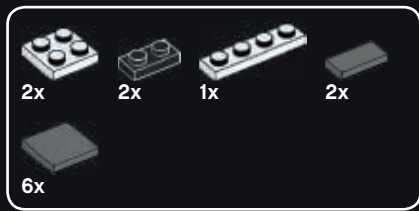

56

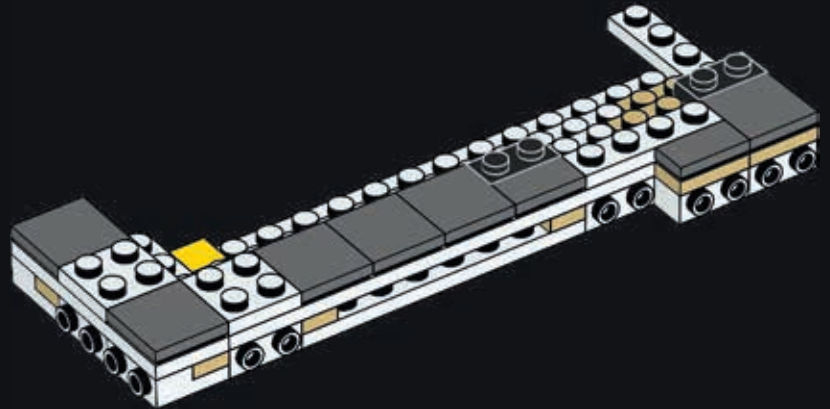

57

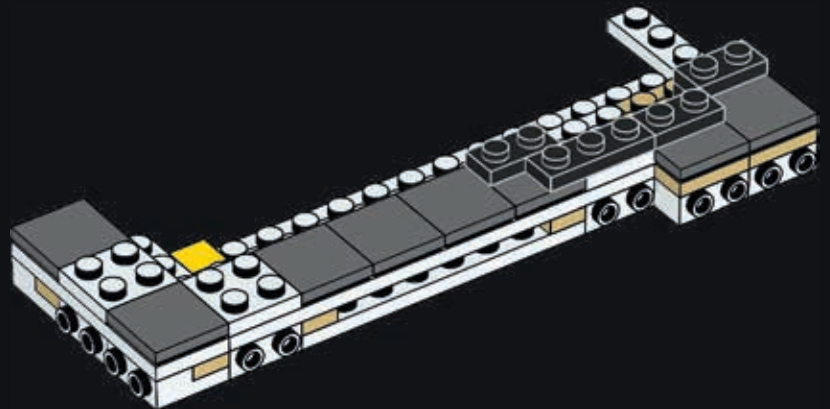

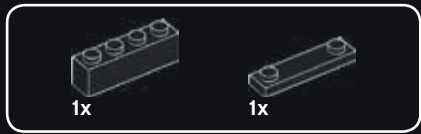

58

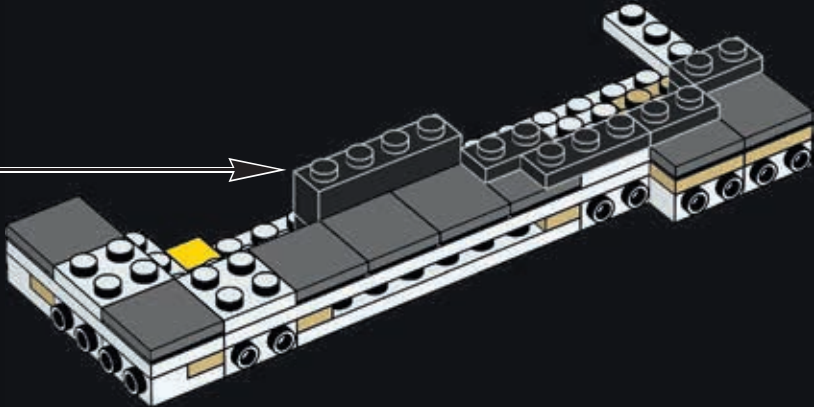
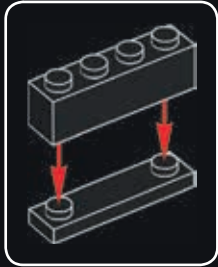

59

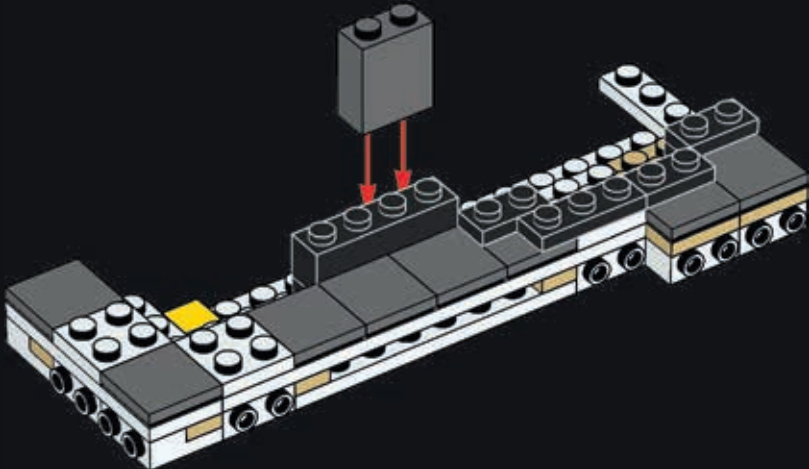



2x

60

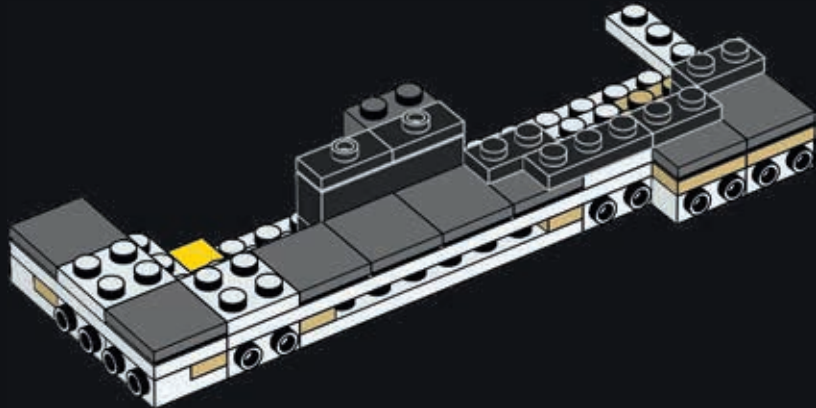

1x

61

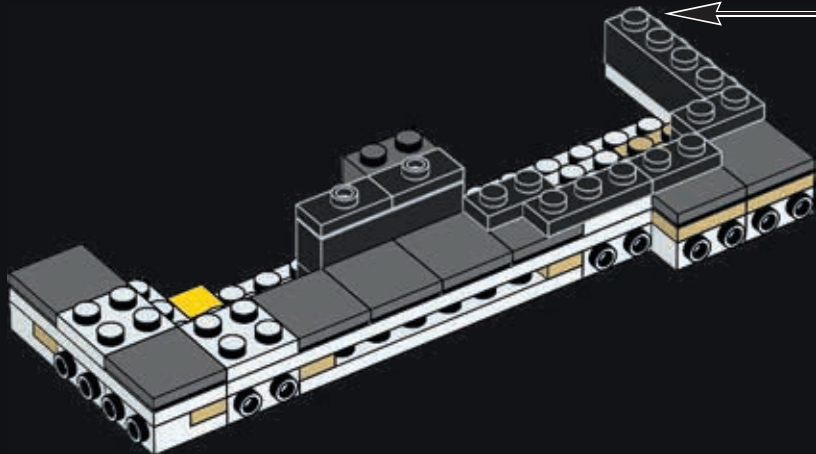



62

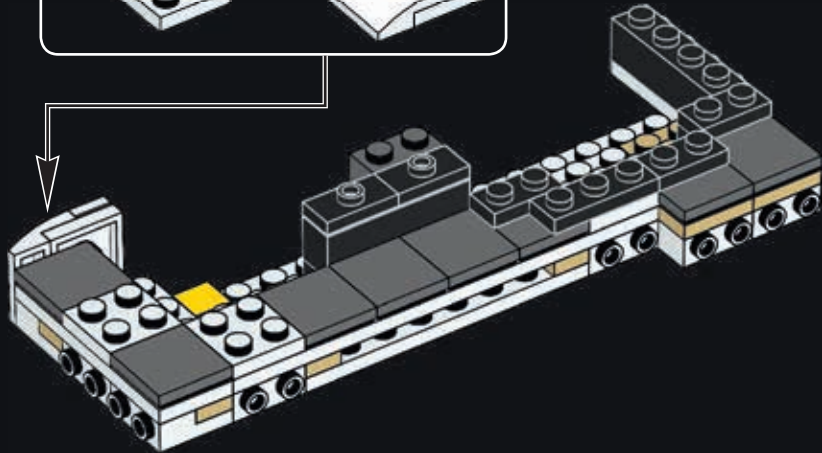
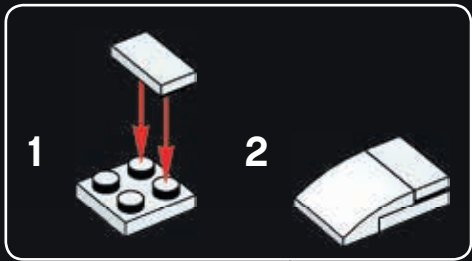

63

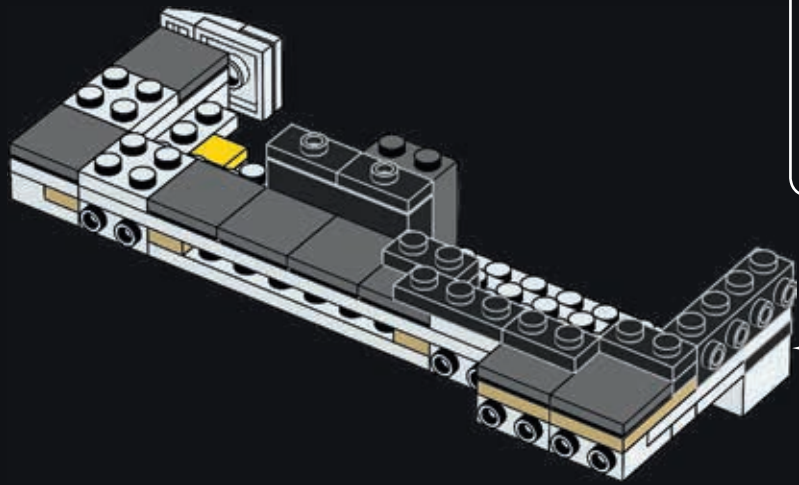
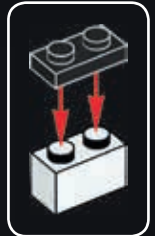

64

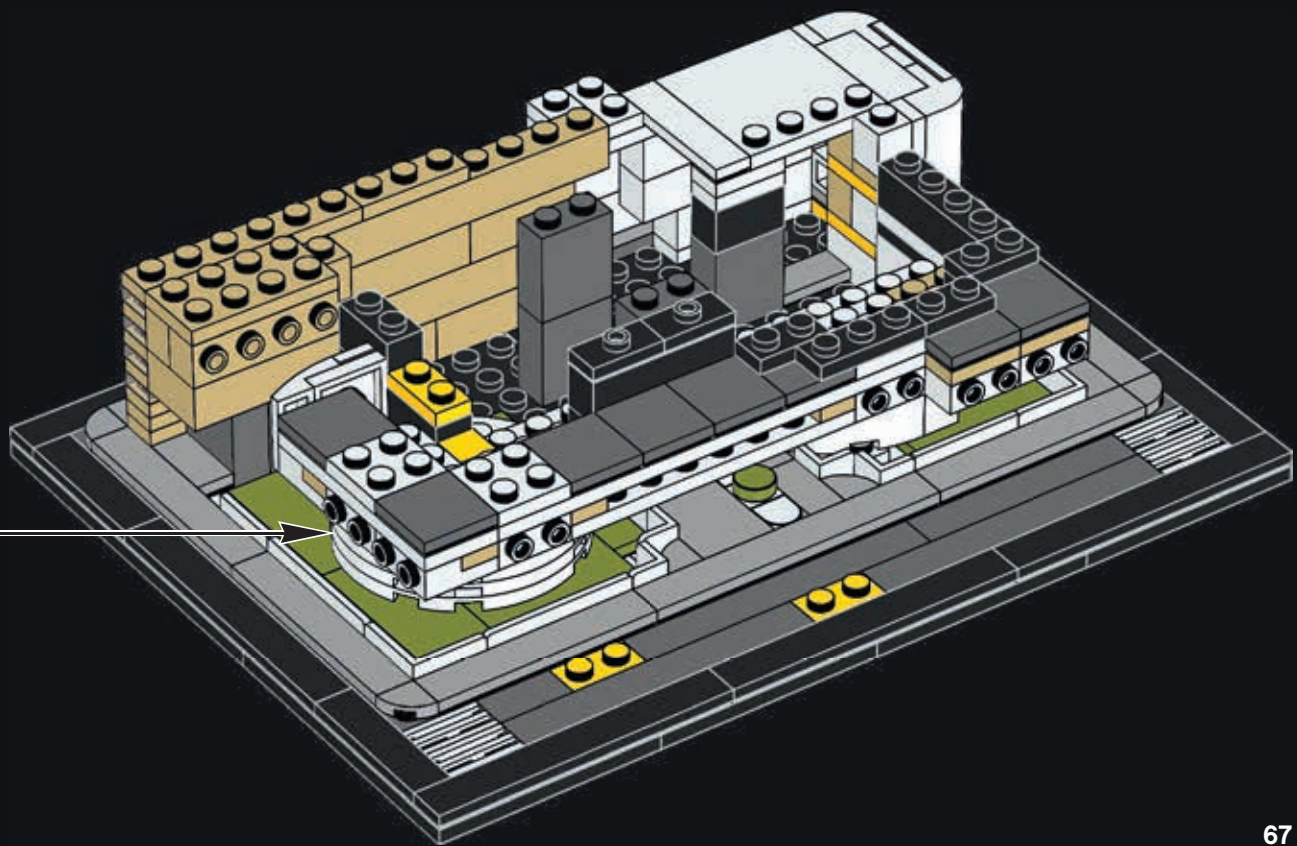

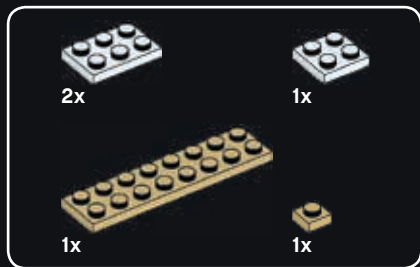

65

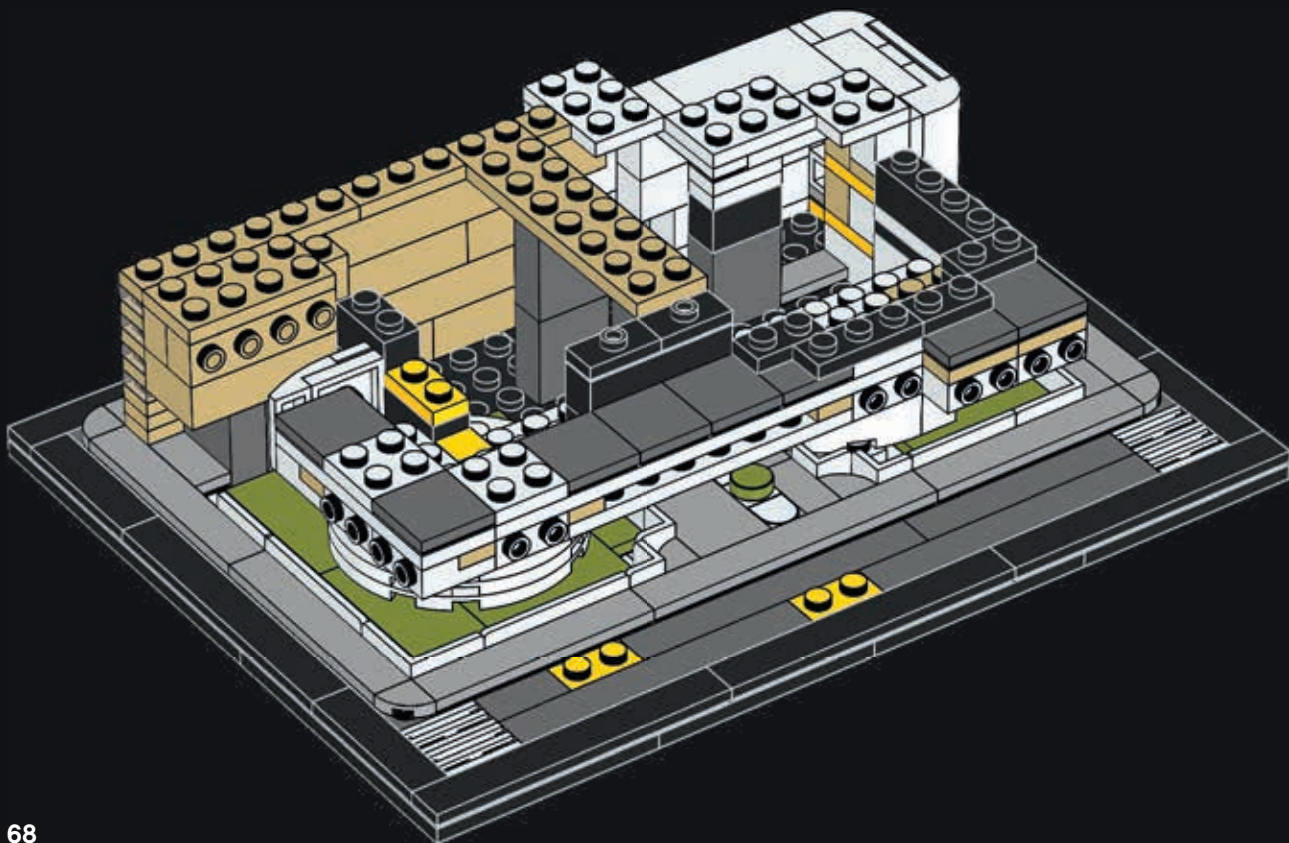

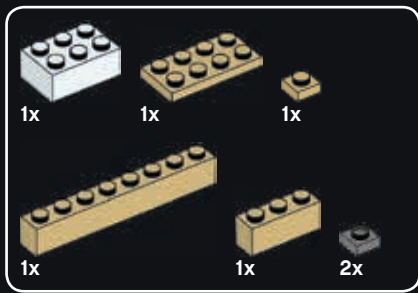

66

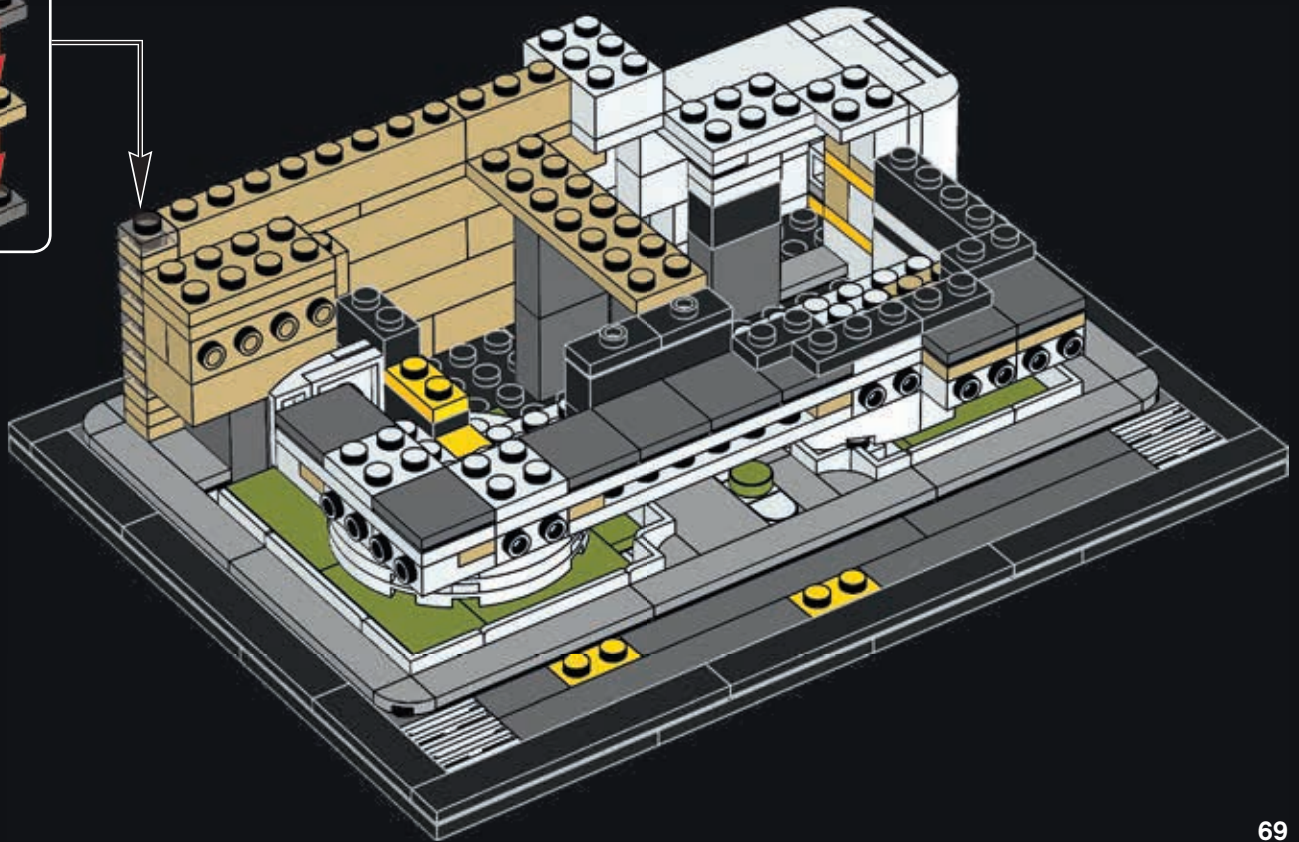
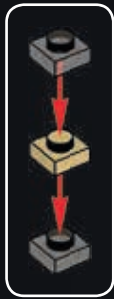

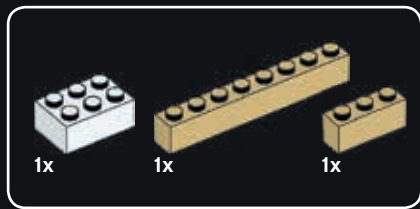

67

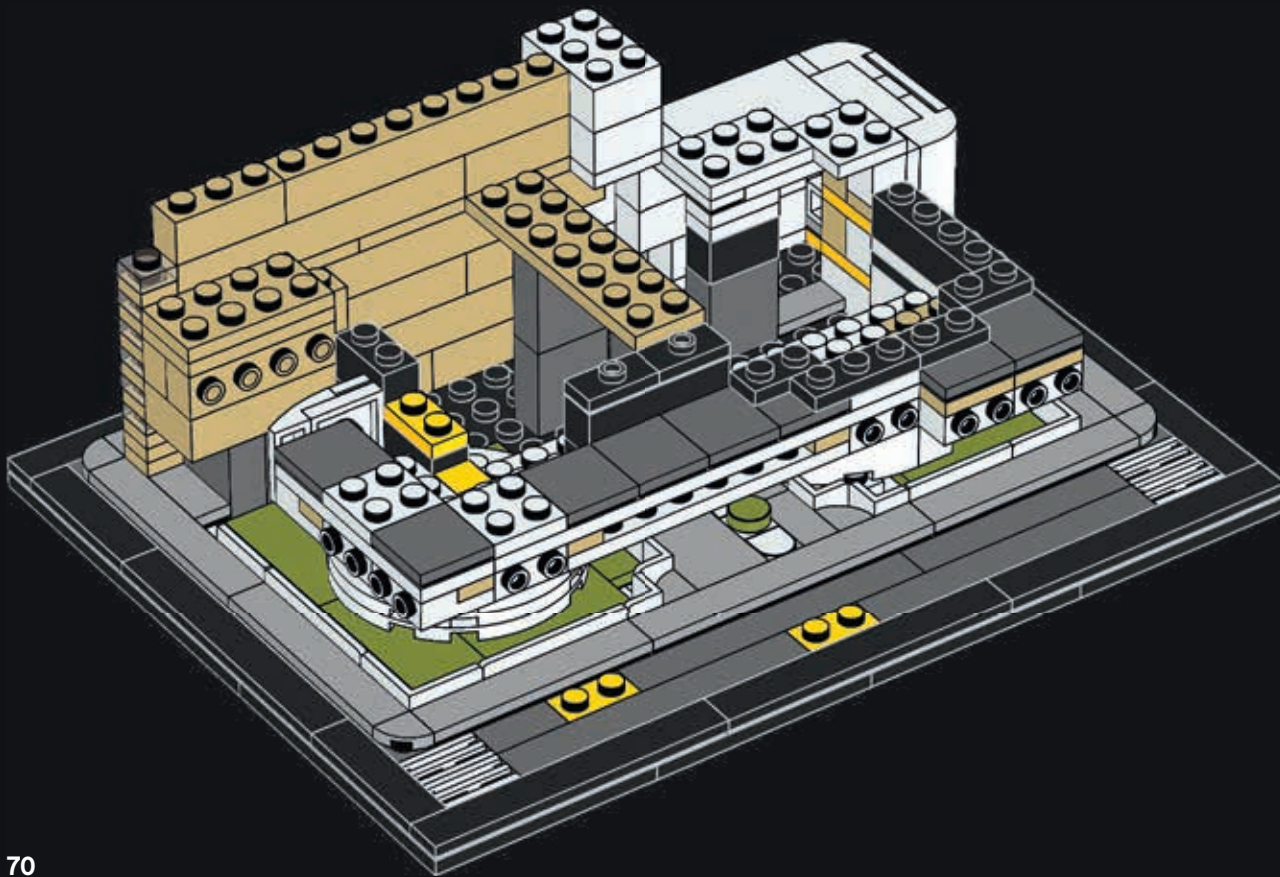



68

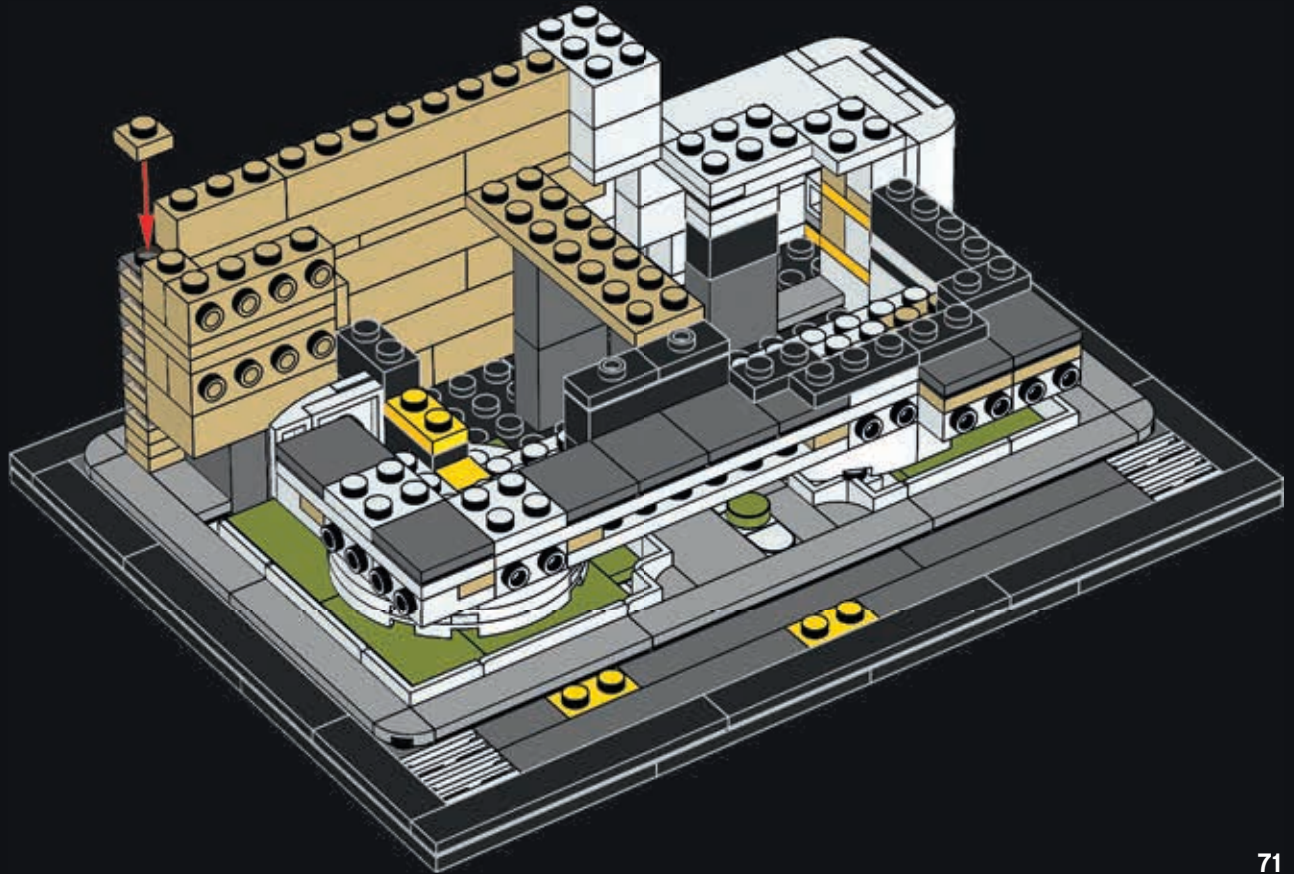



69

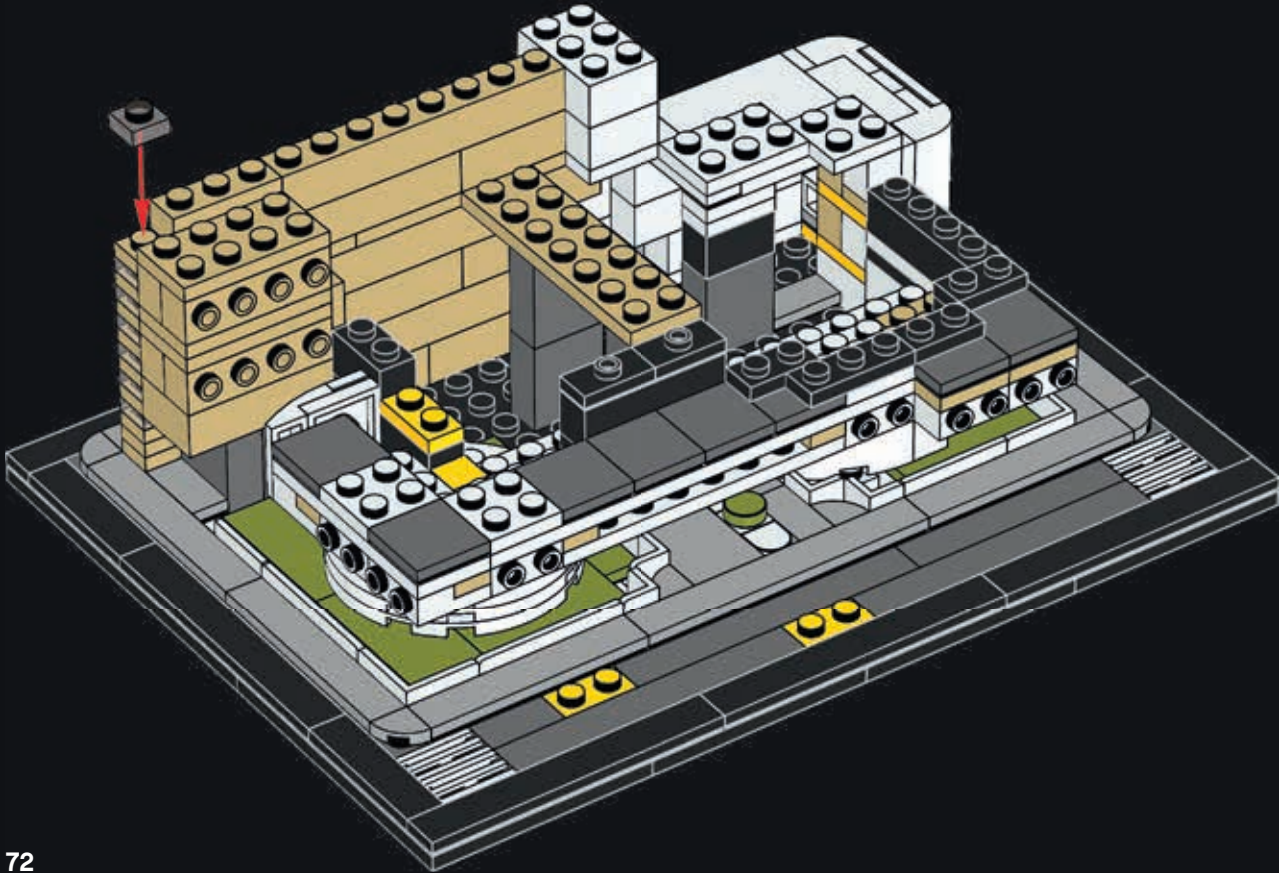



70

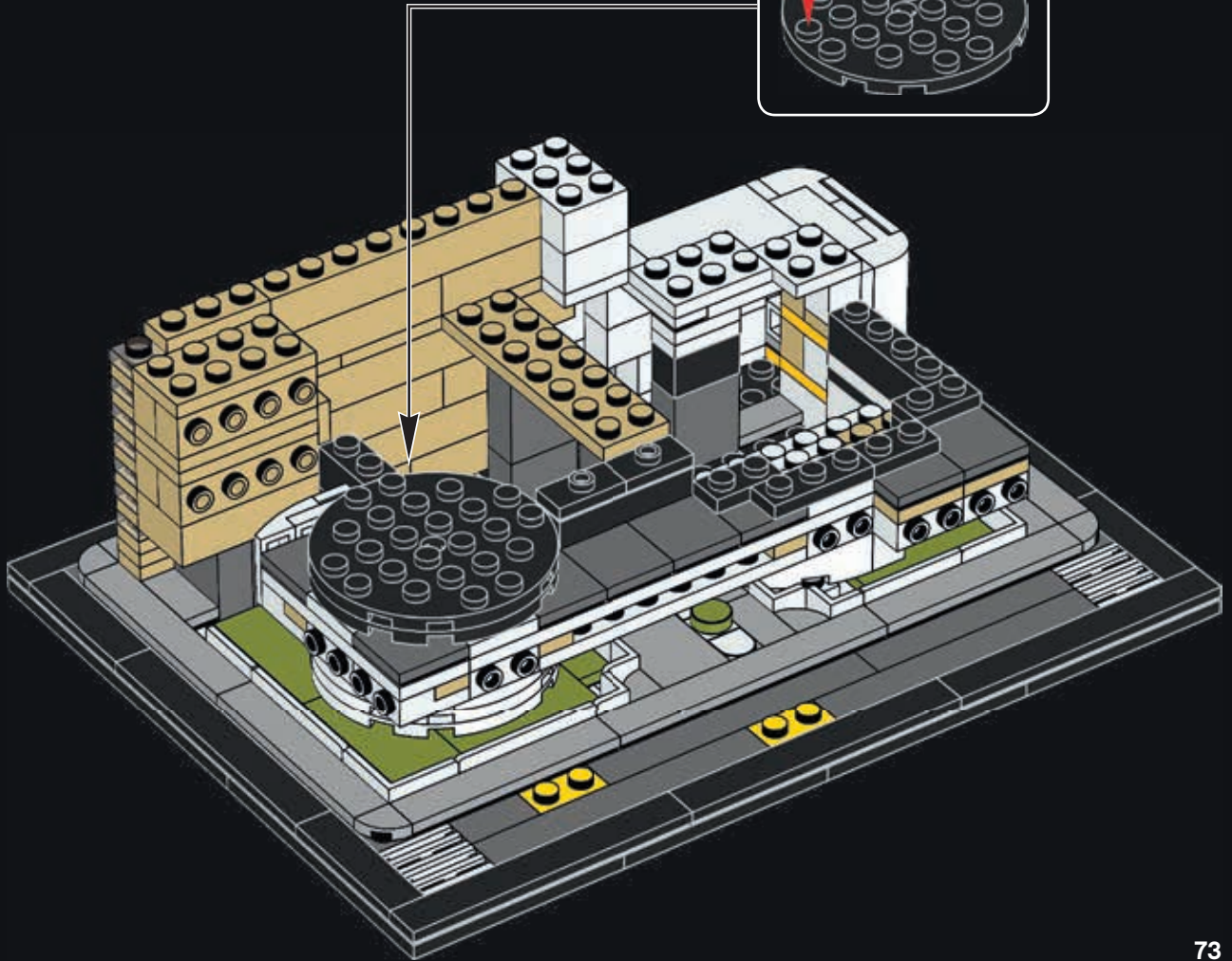
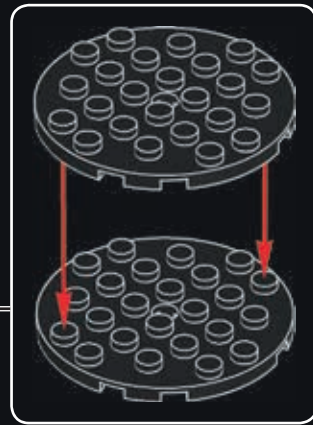



71

1



2

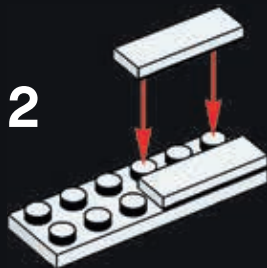

3

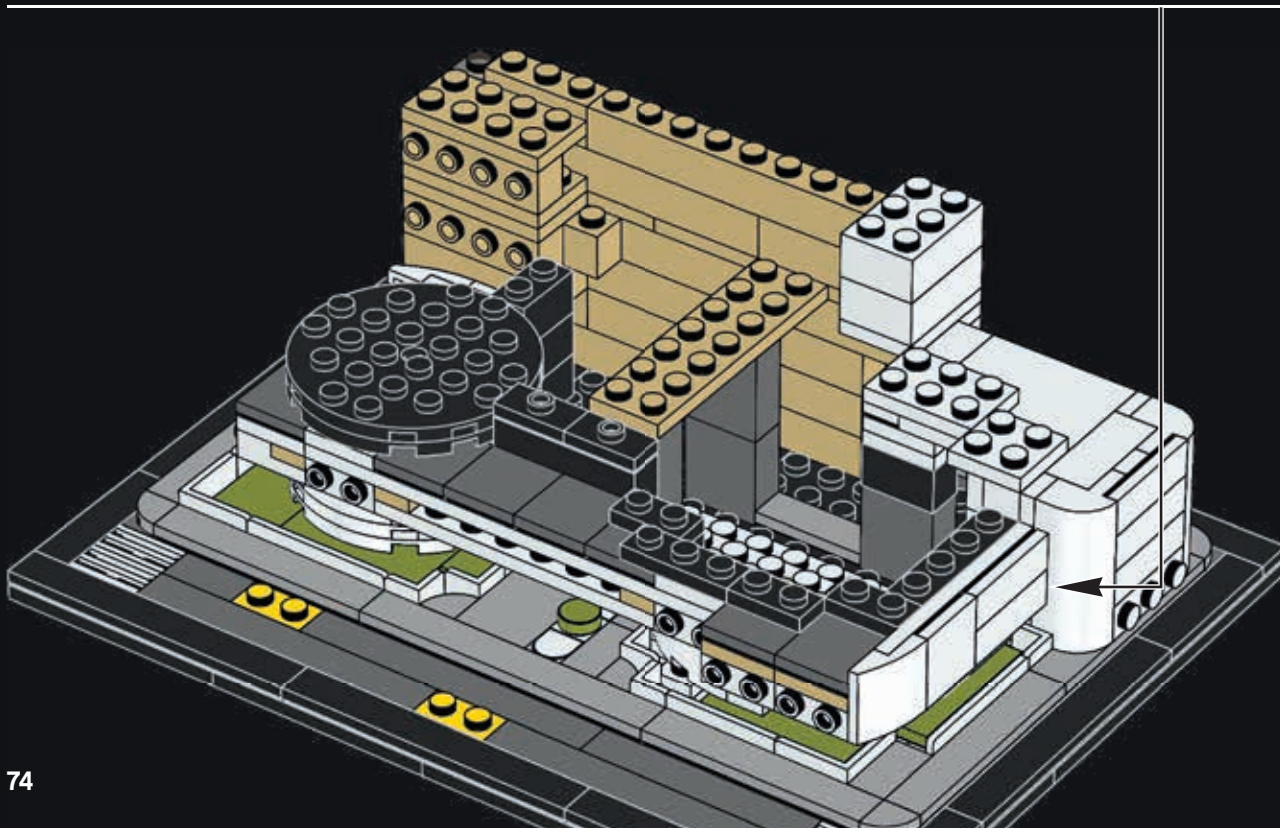
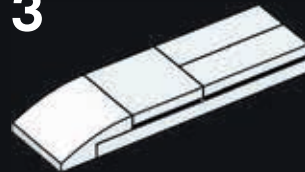



72

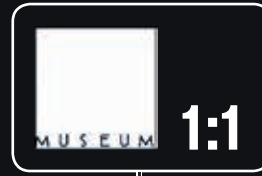

1



2

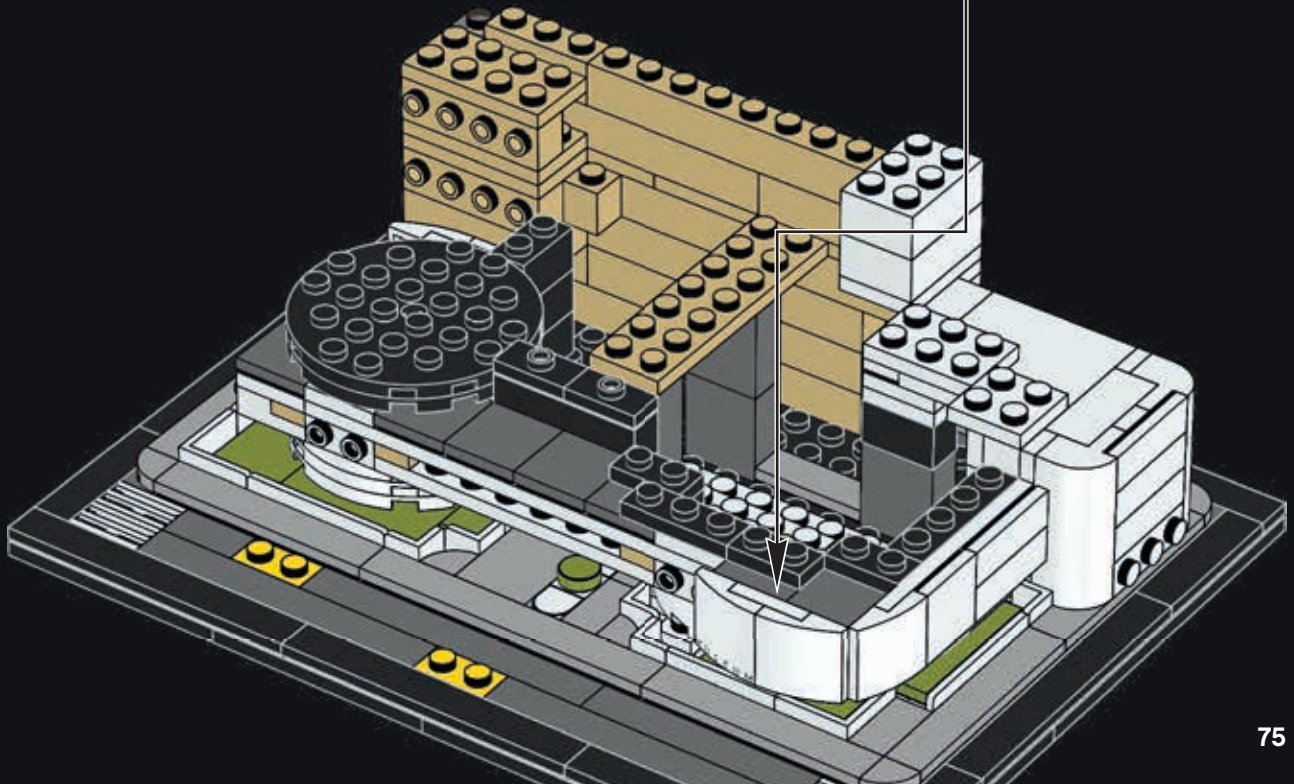

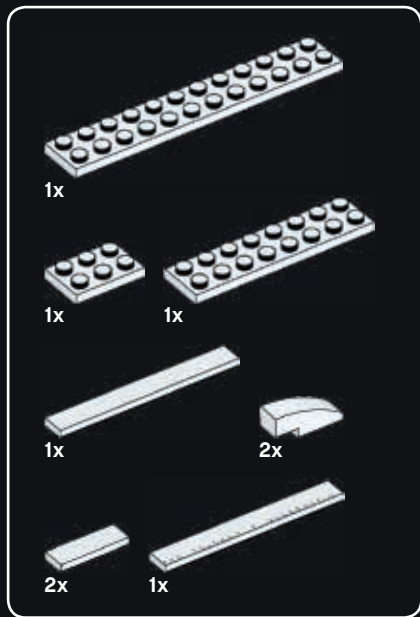

73

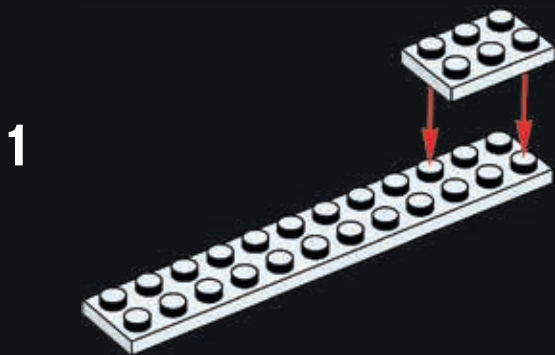

76

2



3



4

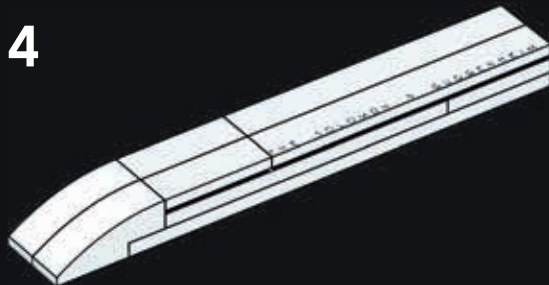

The seal on the floor of
the Guggenheim entrance
says, "Let each man
exercise the art he knows"
– Aristophanes 422 B.C.

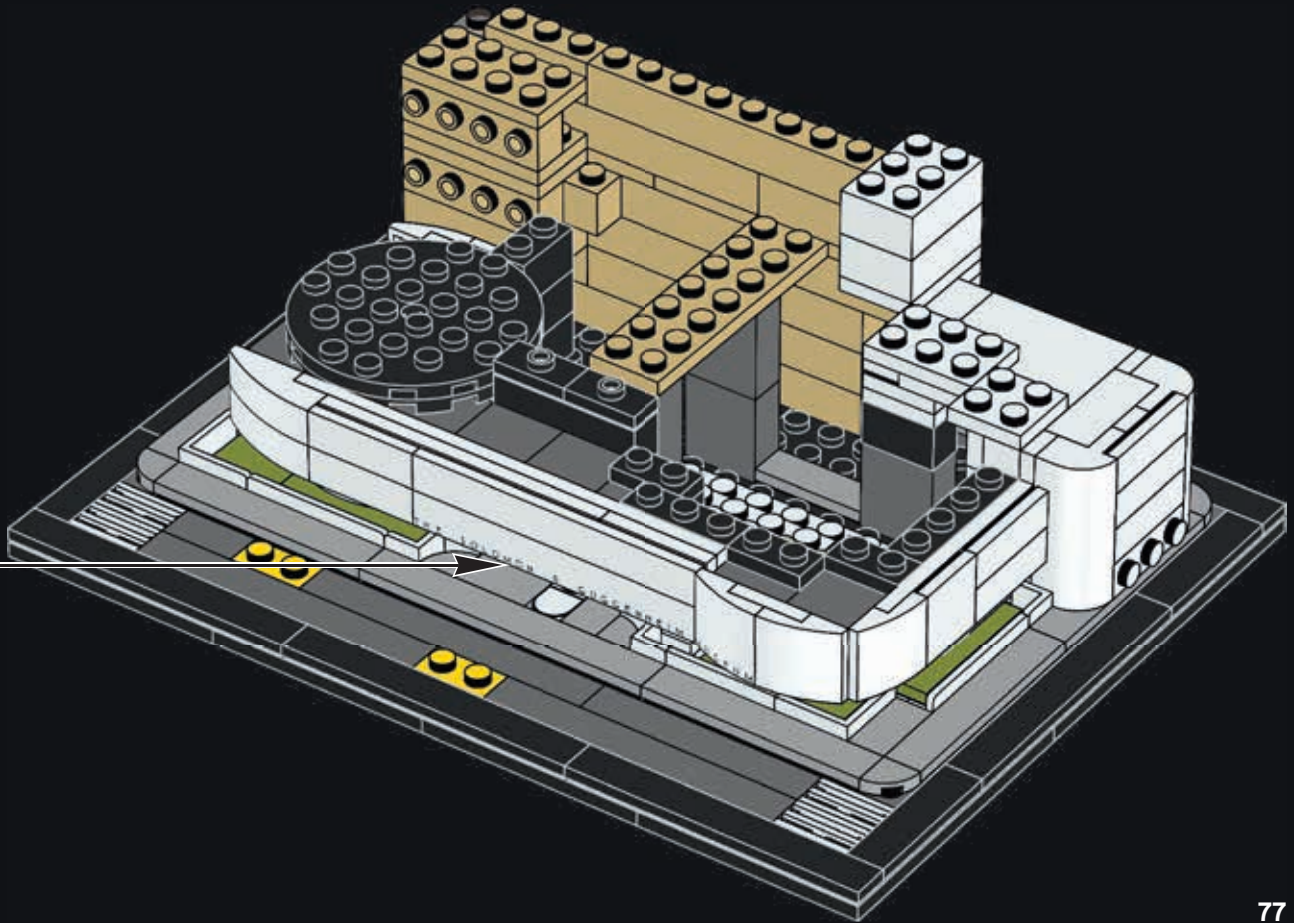



74

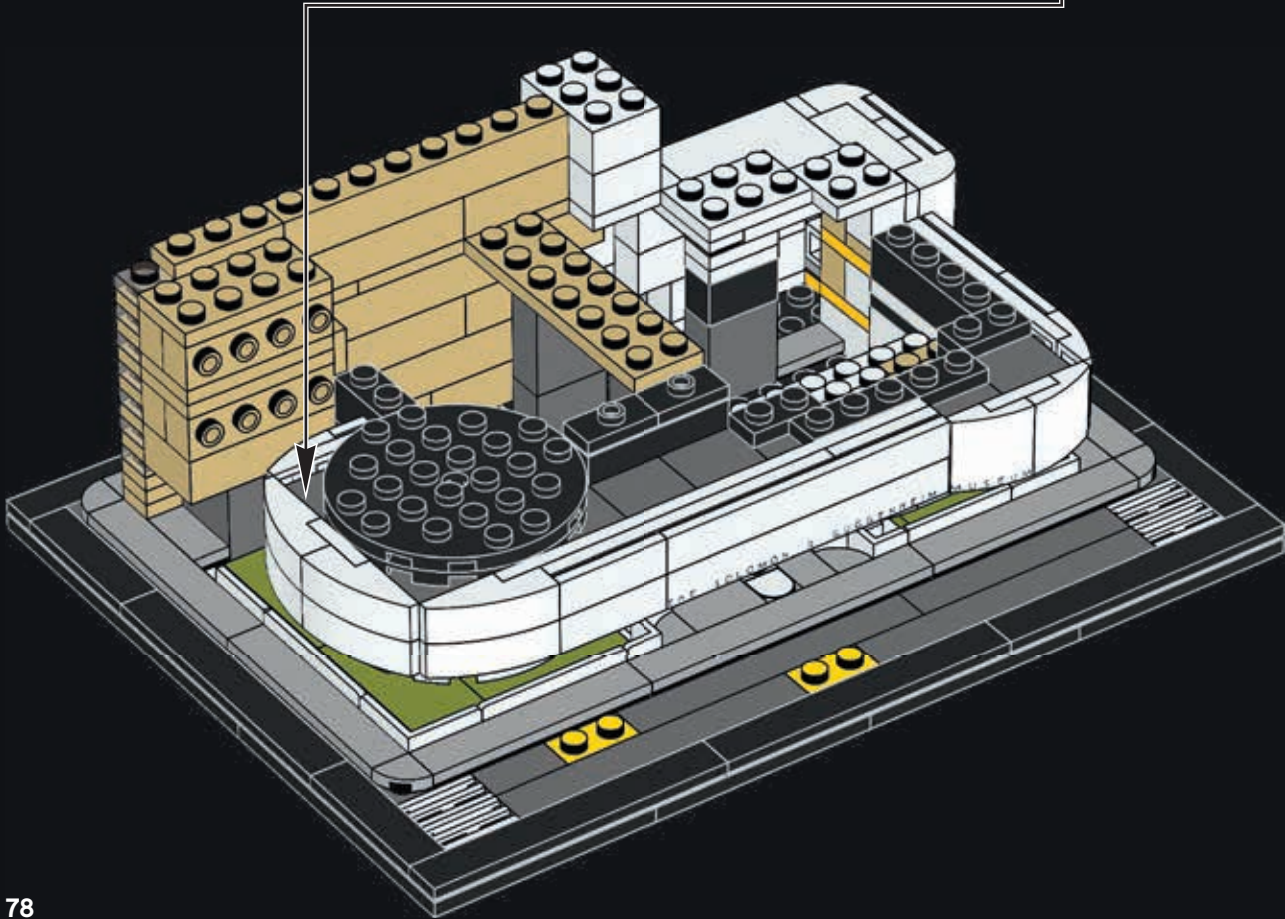
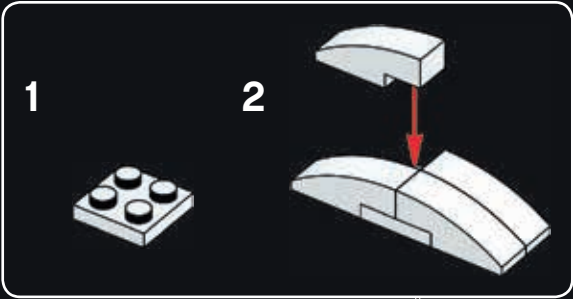



75

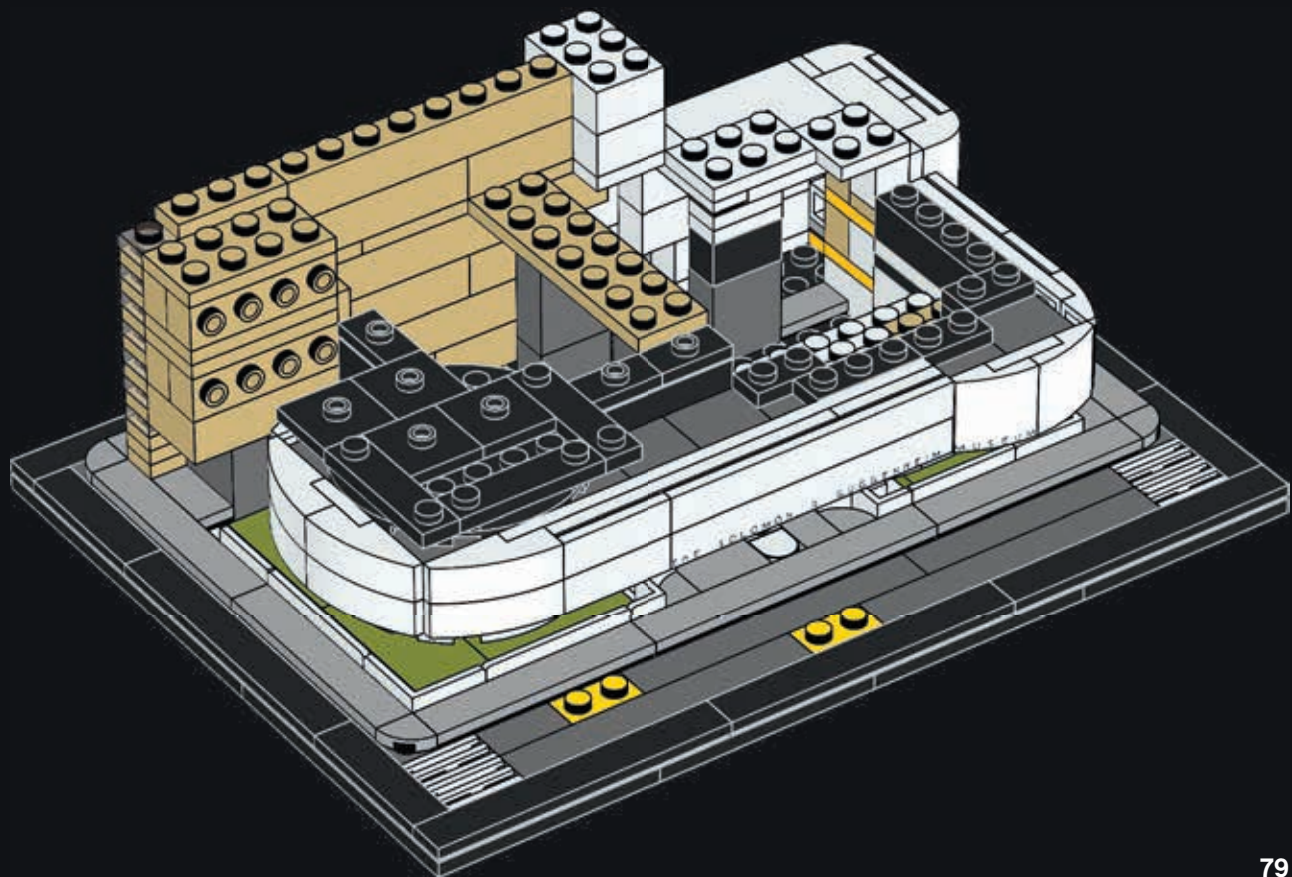



1x

76

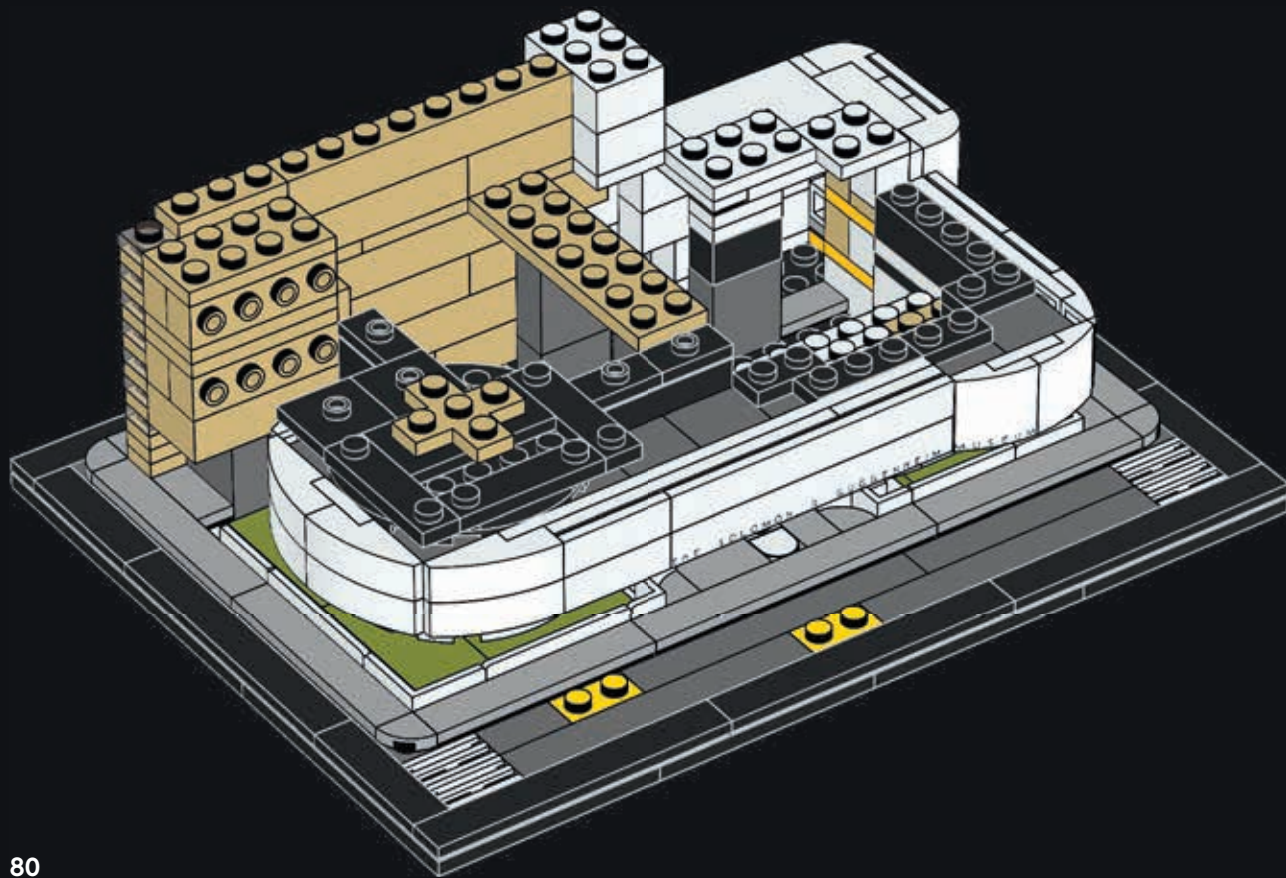



77

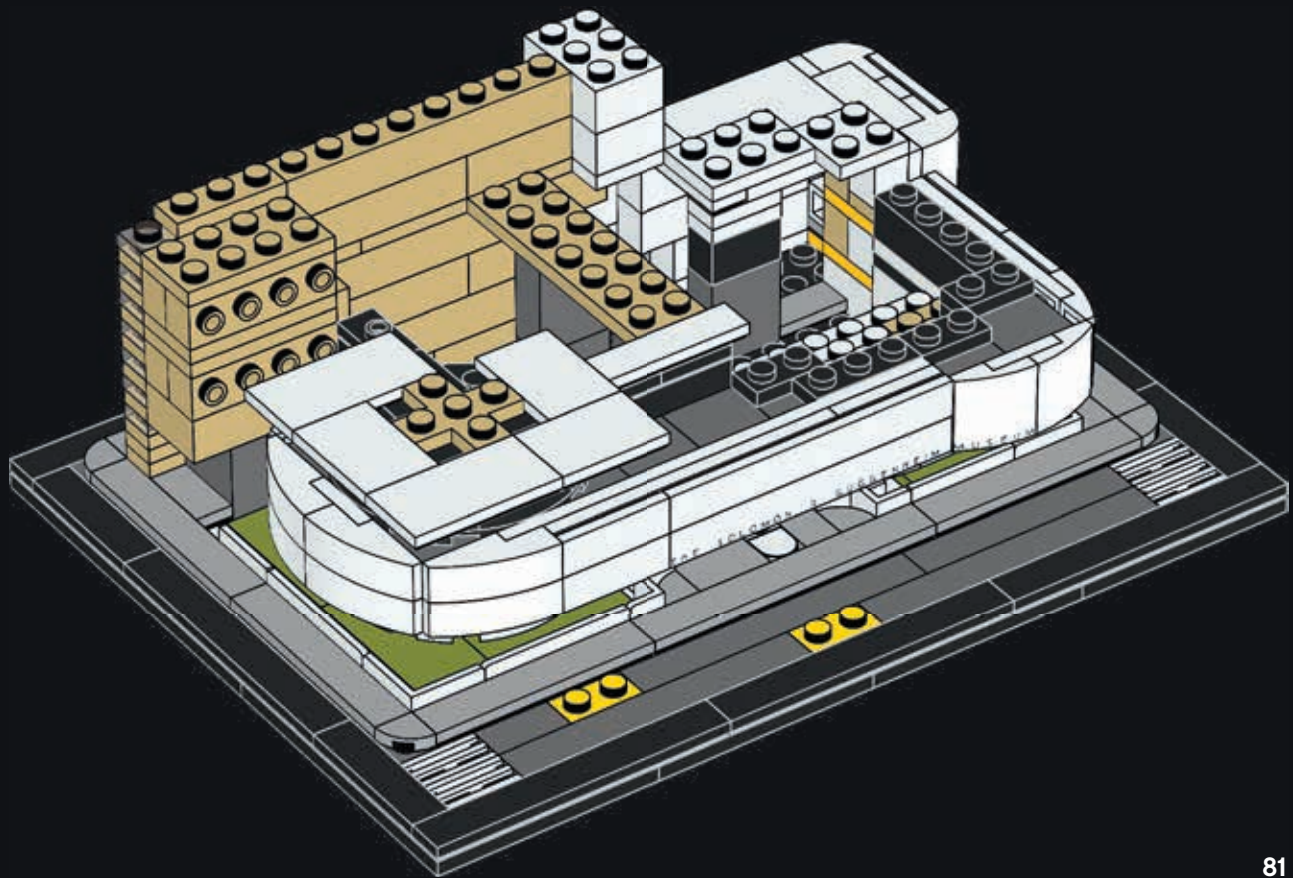



1x

78

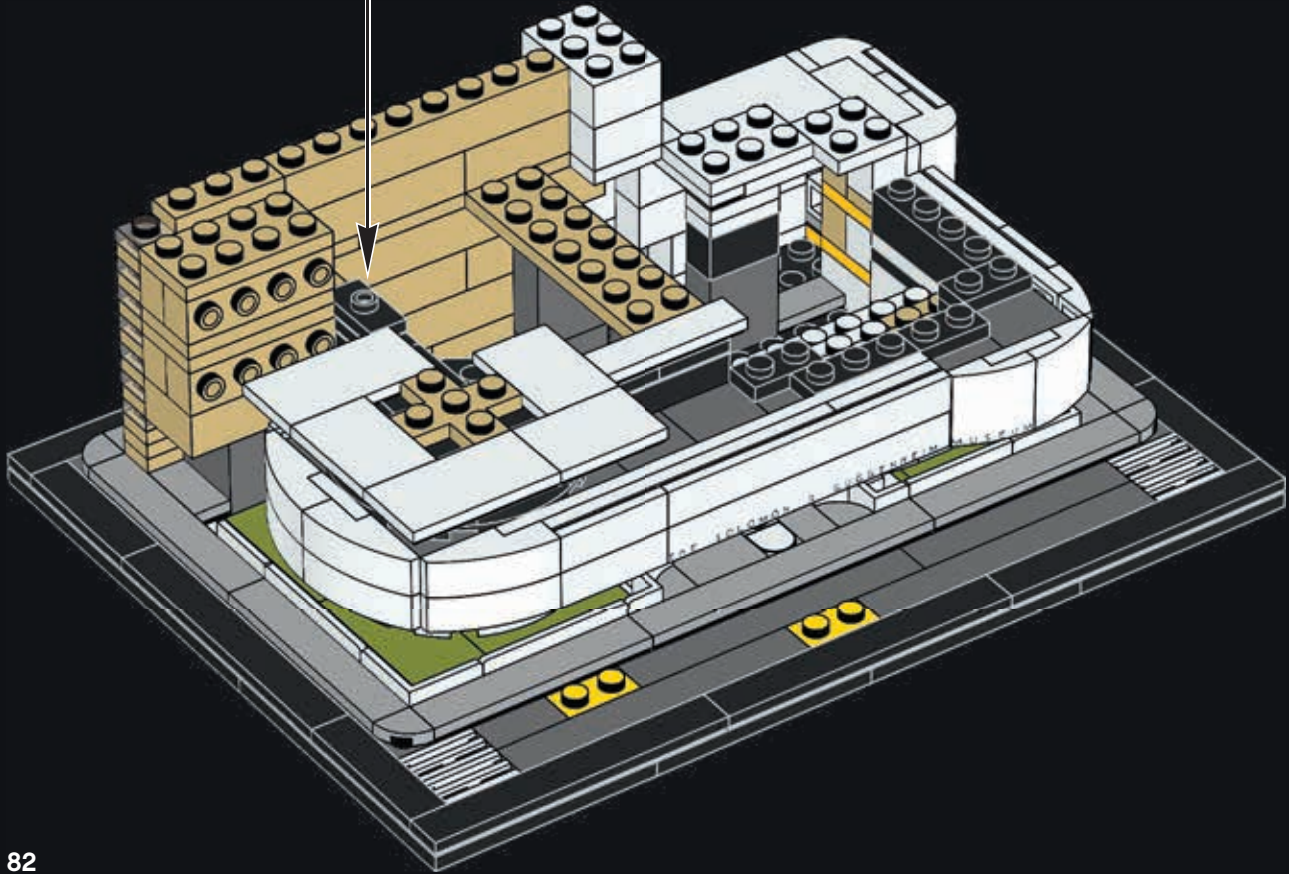



79

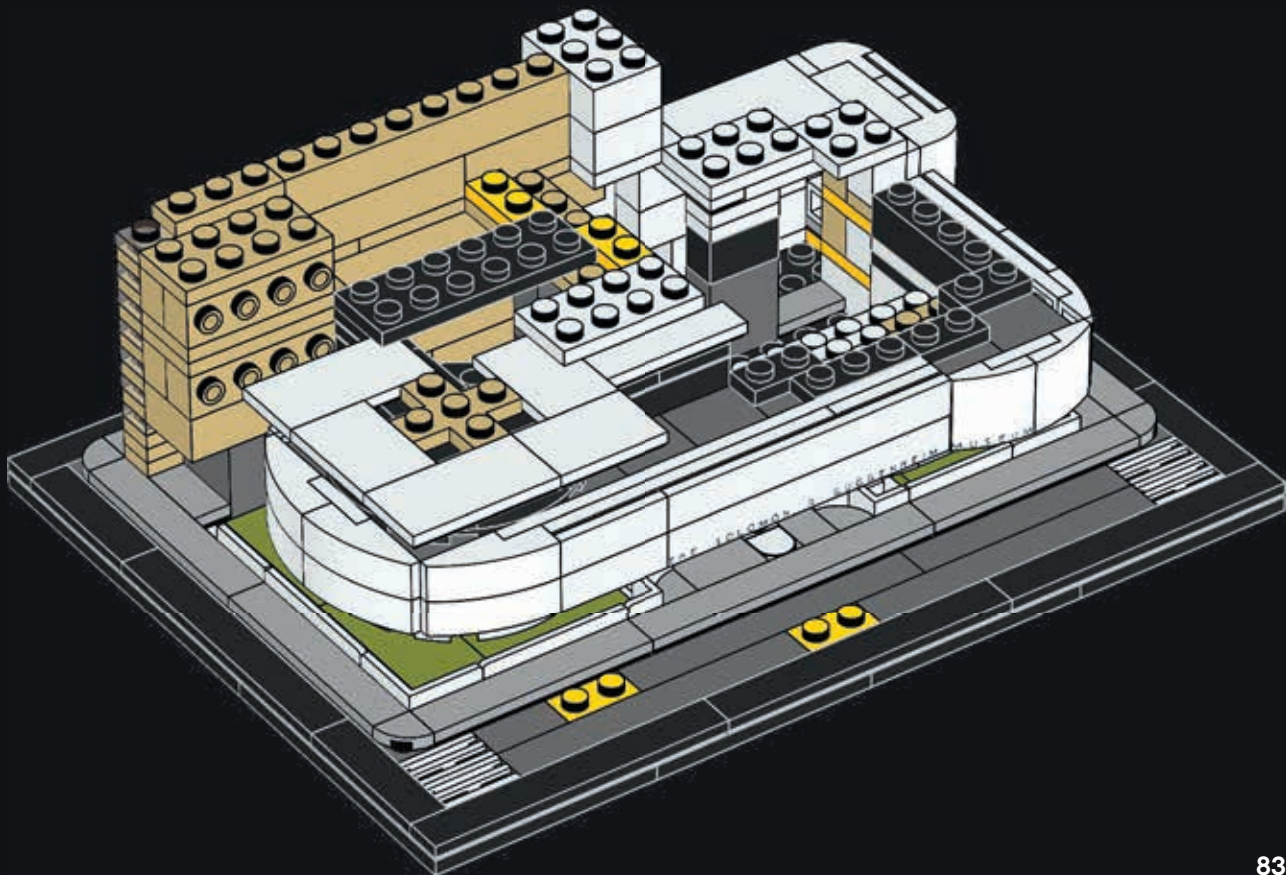

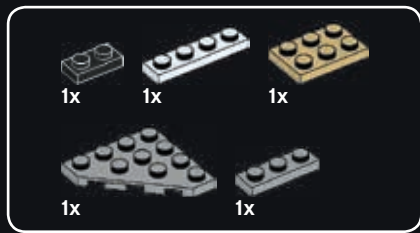

80

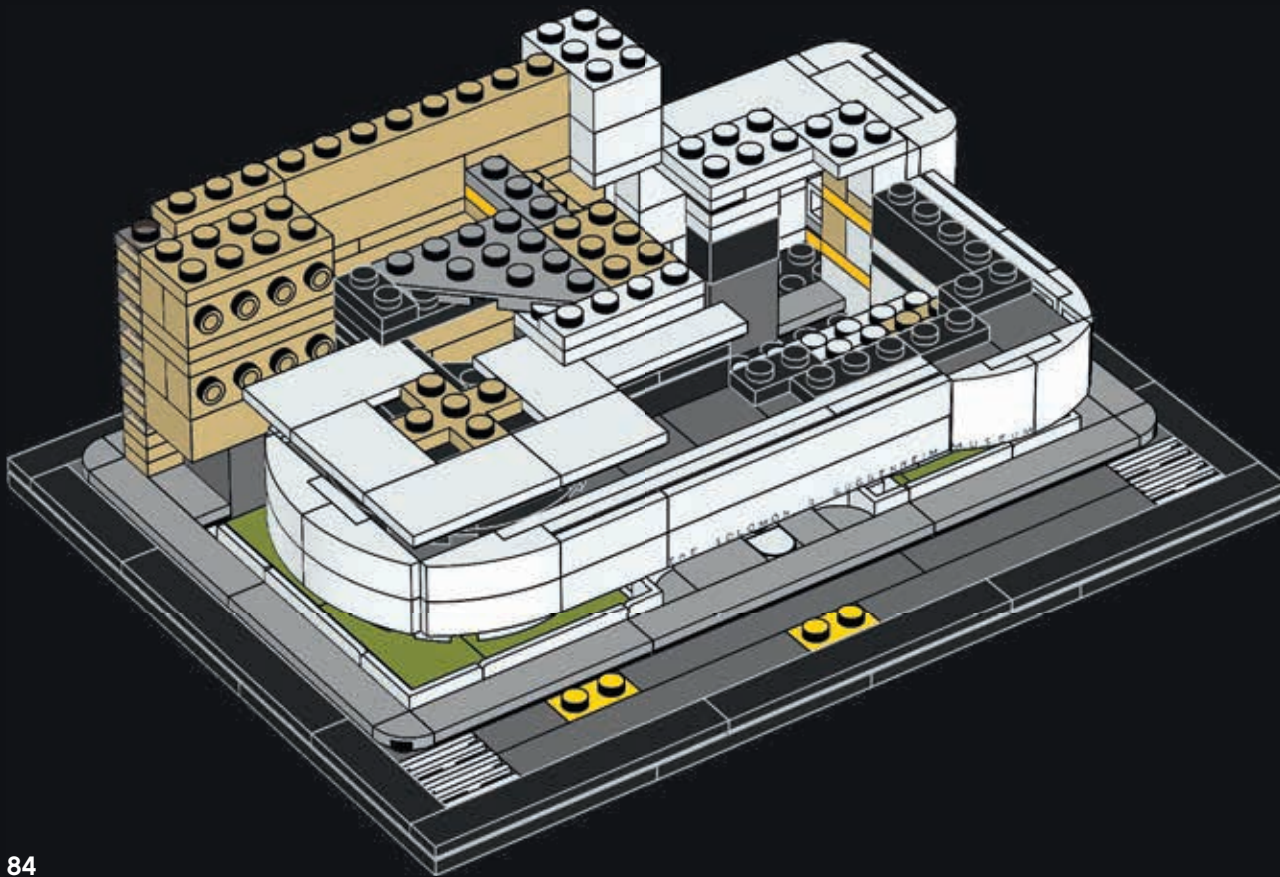



81

The Guggenheim building is made of 700 tons (635,000 kg) of steel and 7,000 cubic feet (198.2 cubic meters) of poured concrete.

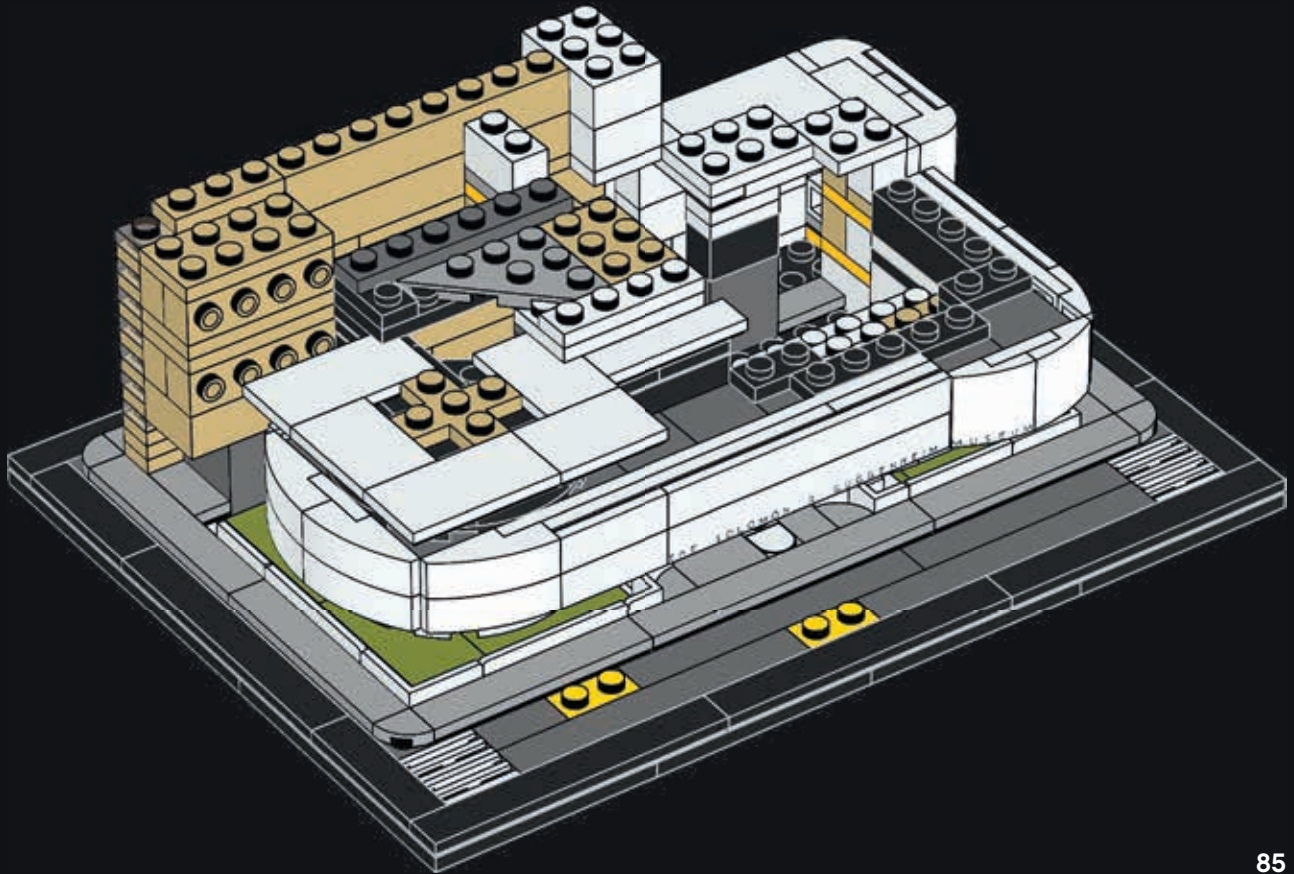



82

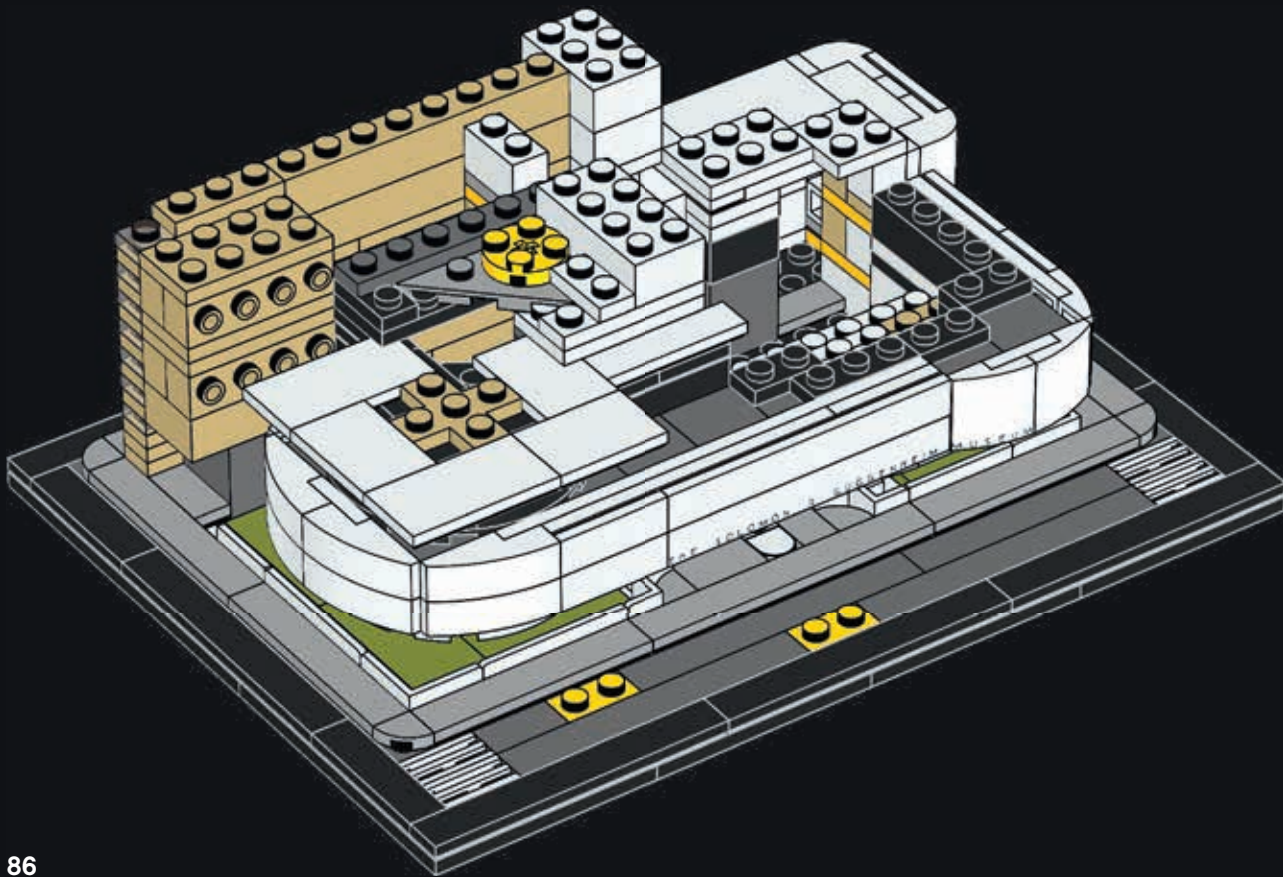



83

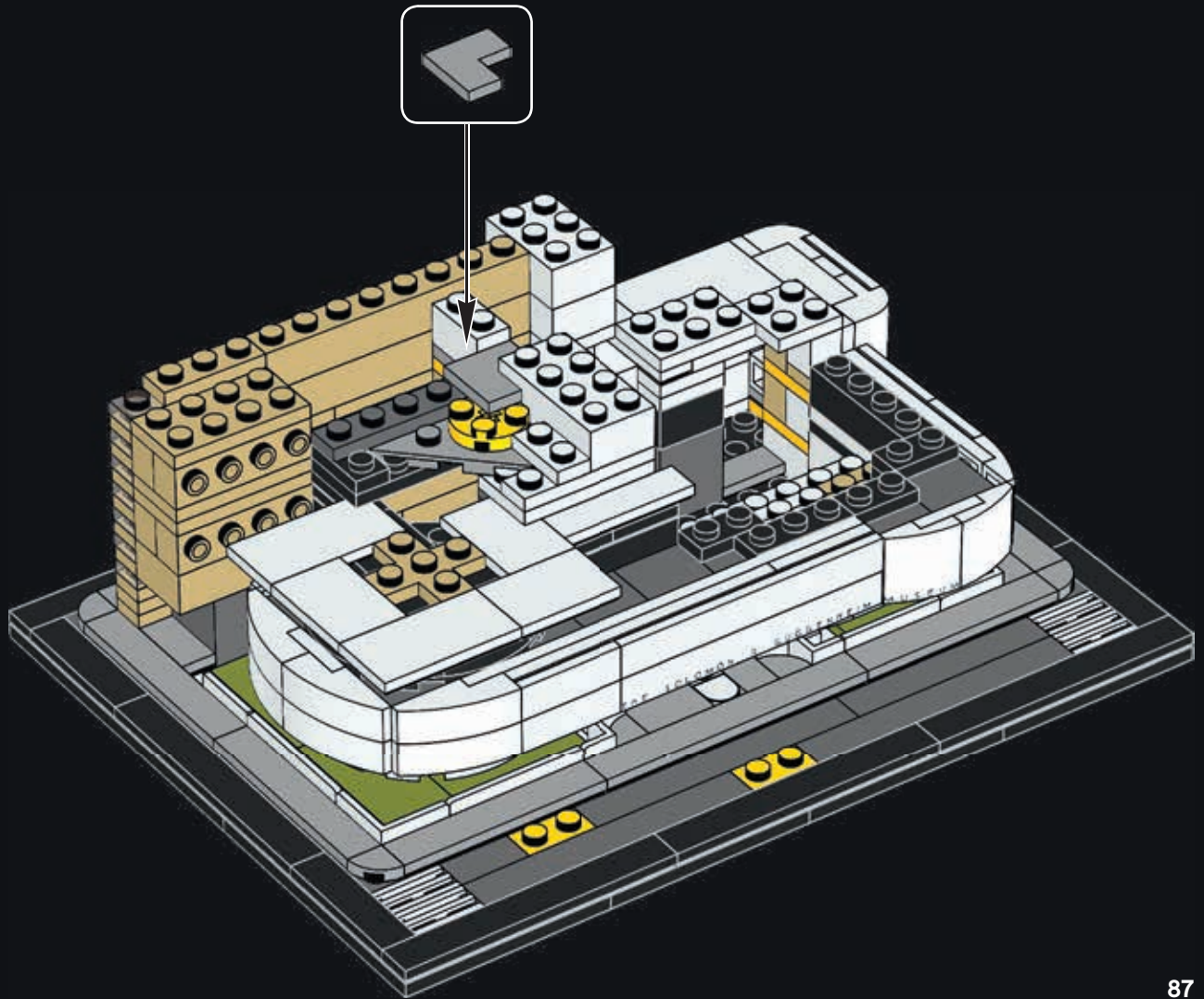

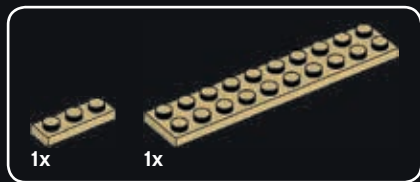

84

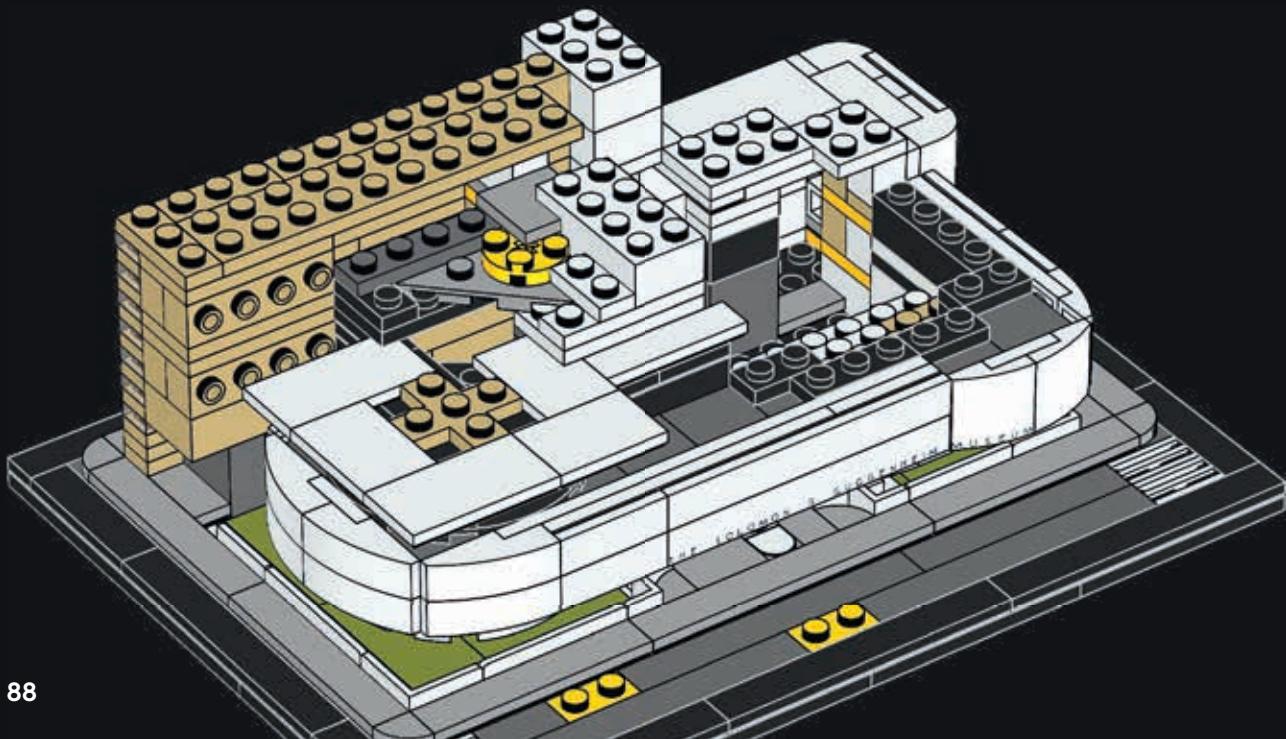



85

1



2



3



4

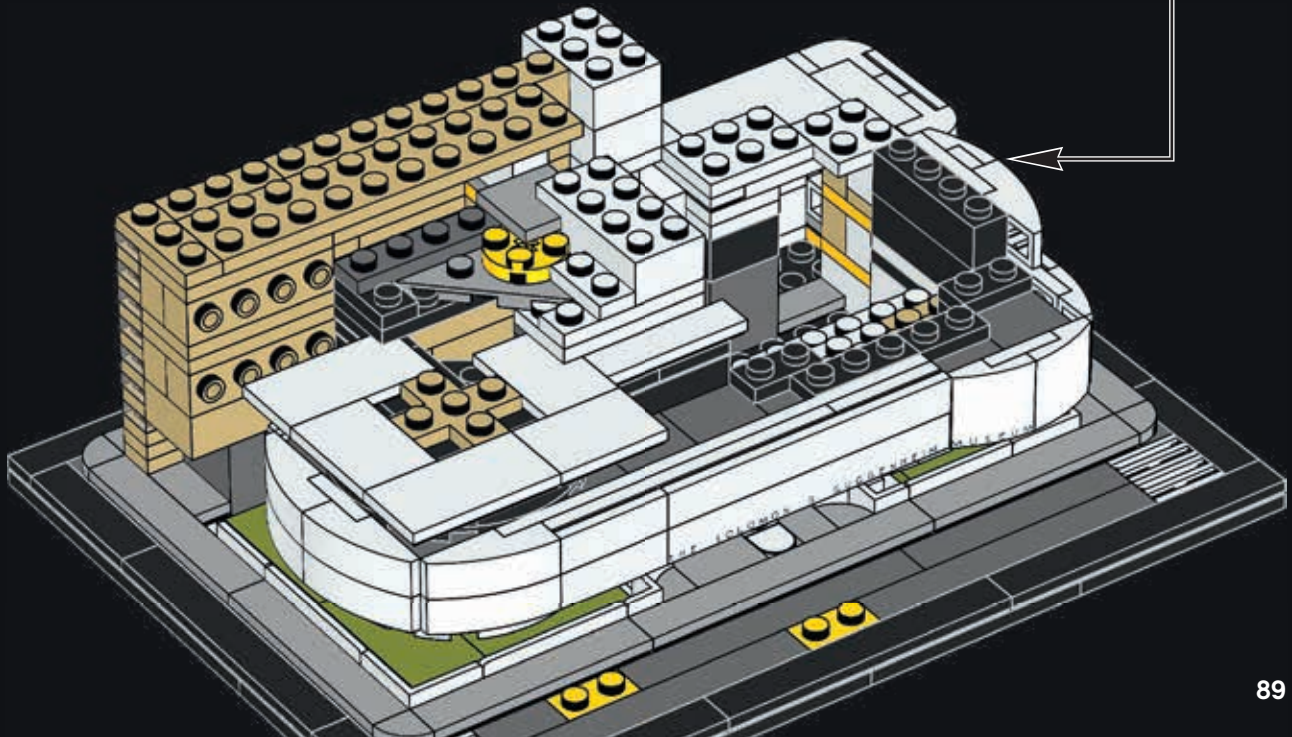
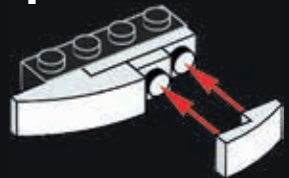

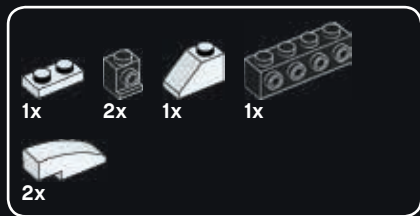

86

1

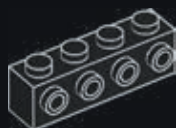

2



3



4

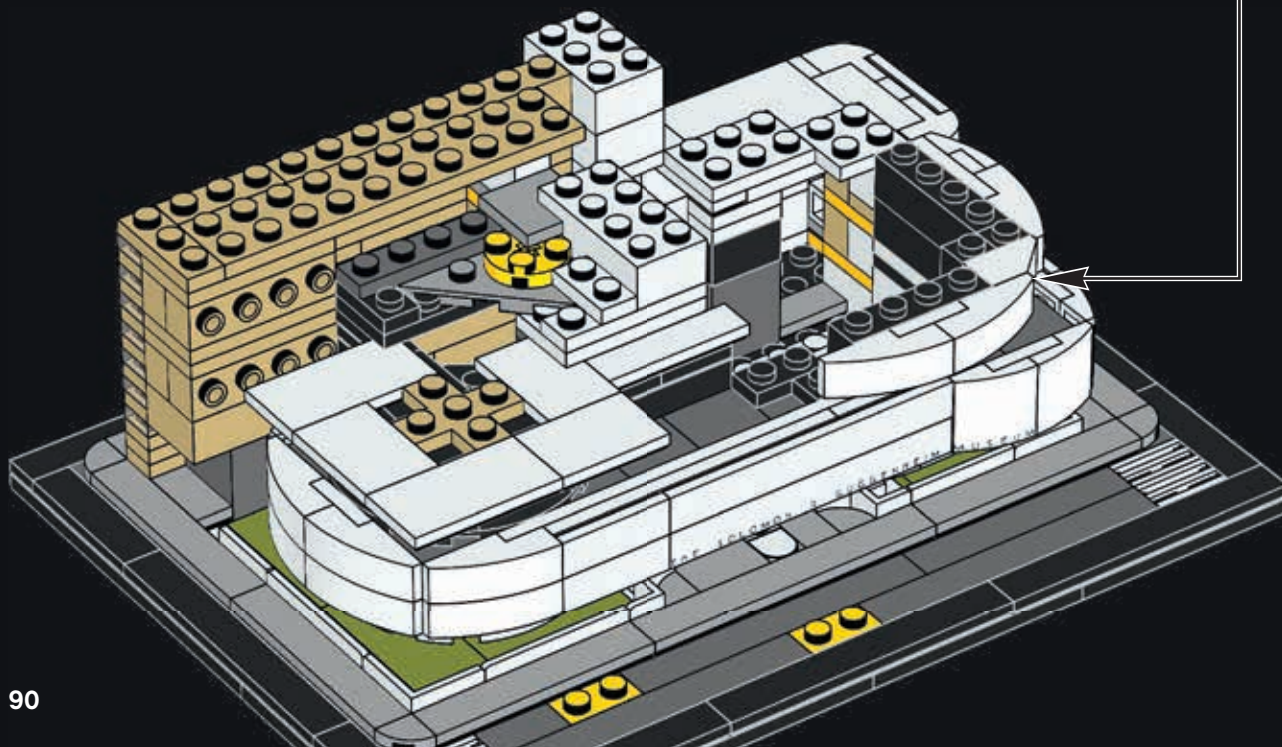
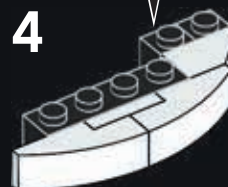



1x

87

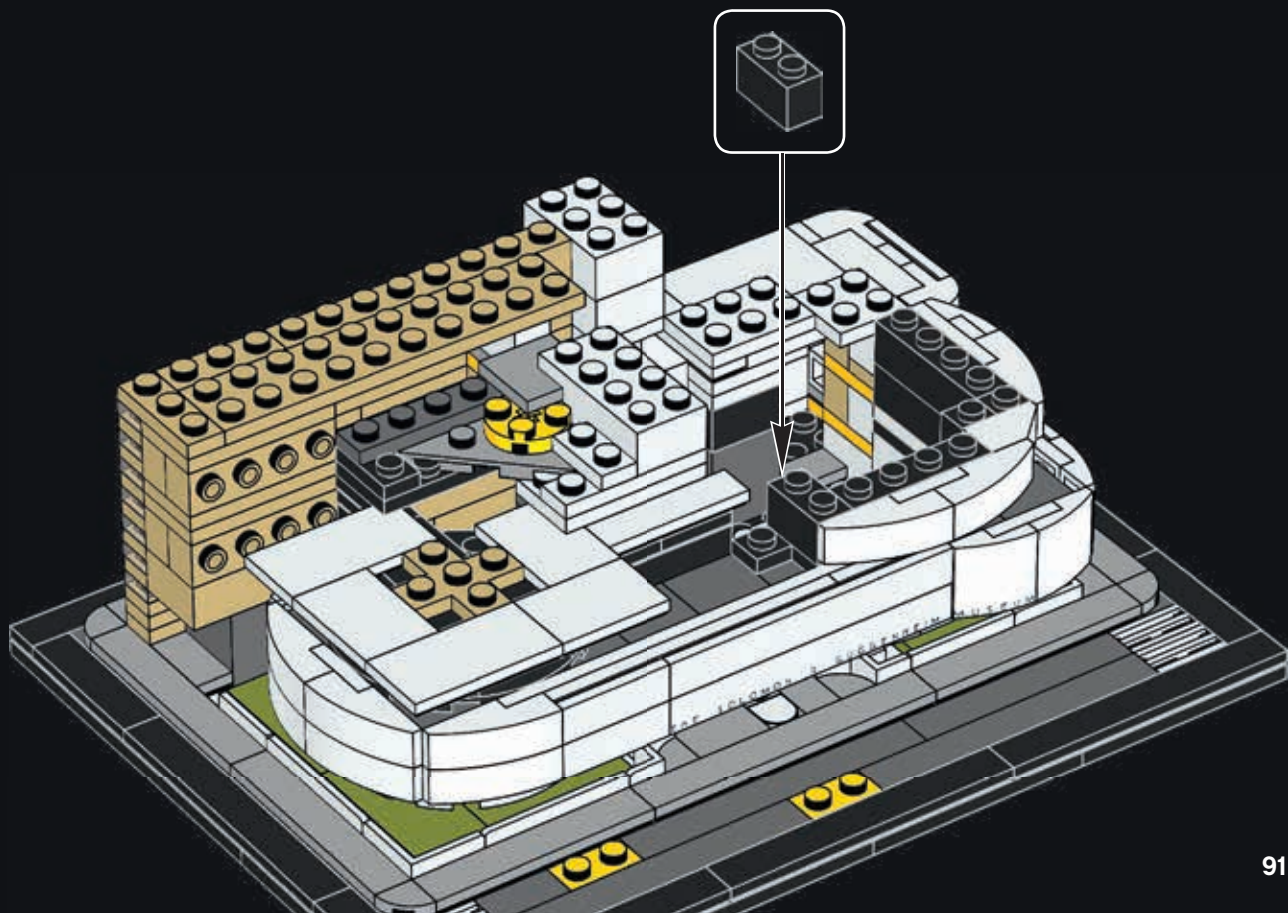

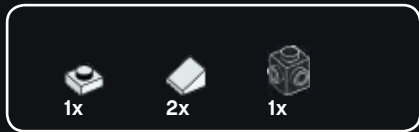

88

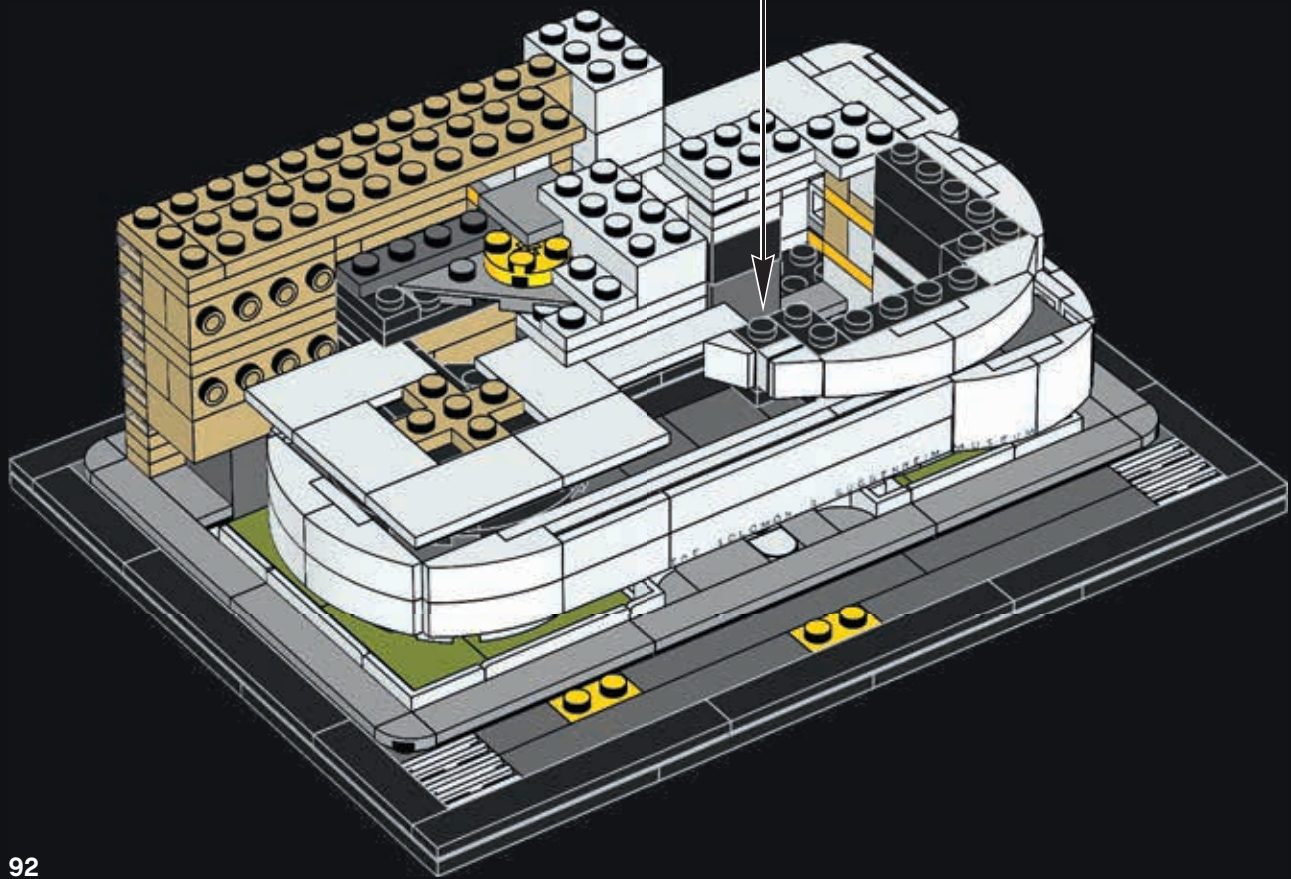



2x



1x



3x



1x

89

1

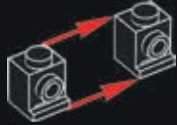

2



3



4



5

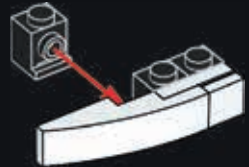

6



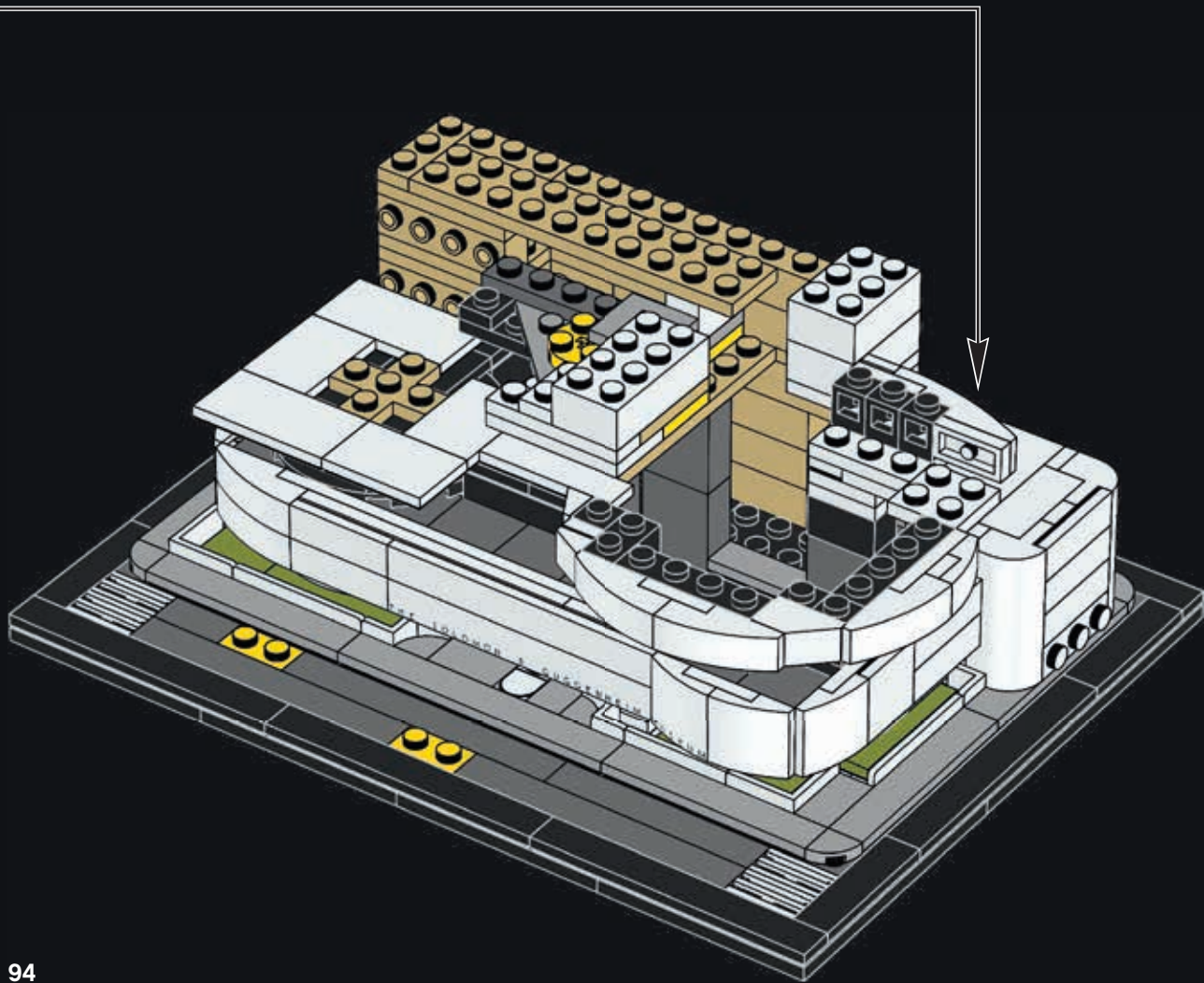



2x

90

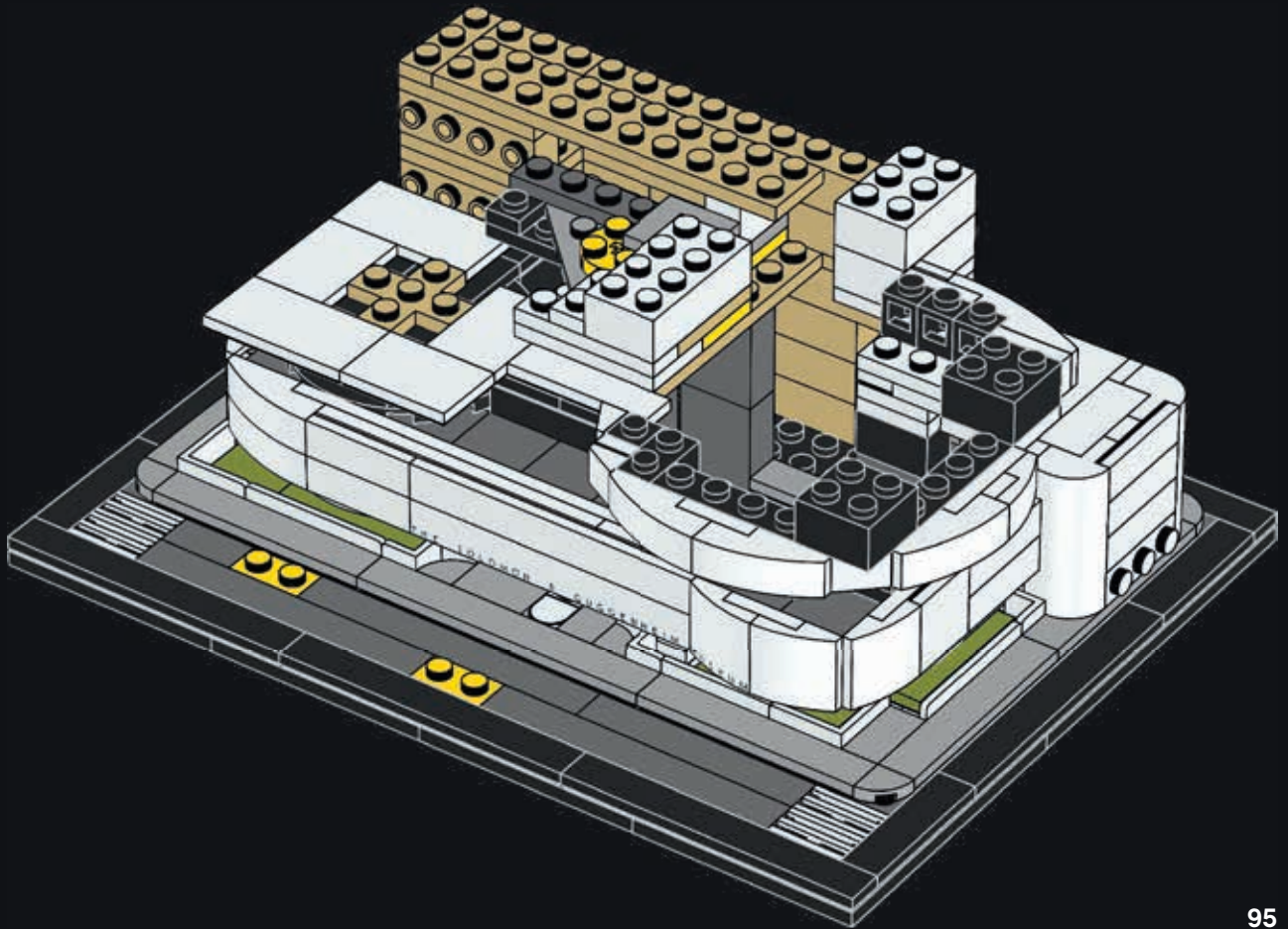



2x



91

1



2

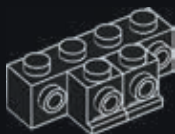

3

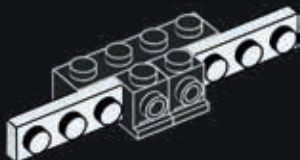

4

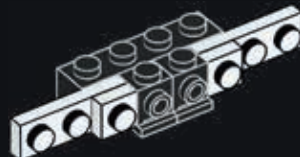

5



6

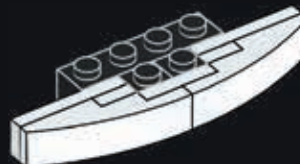

2x

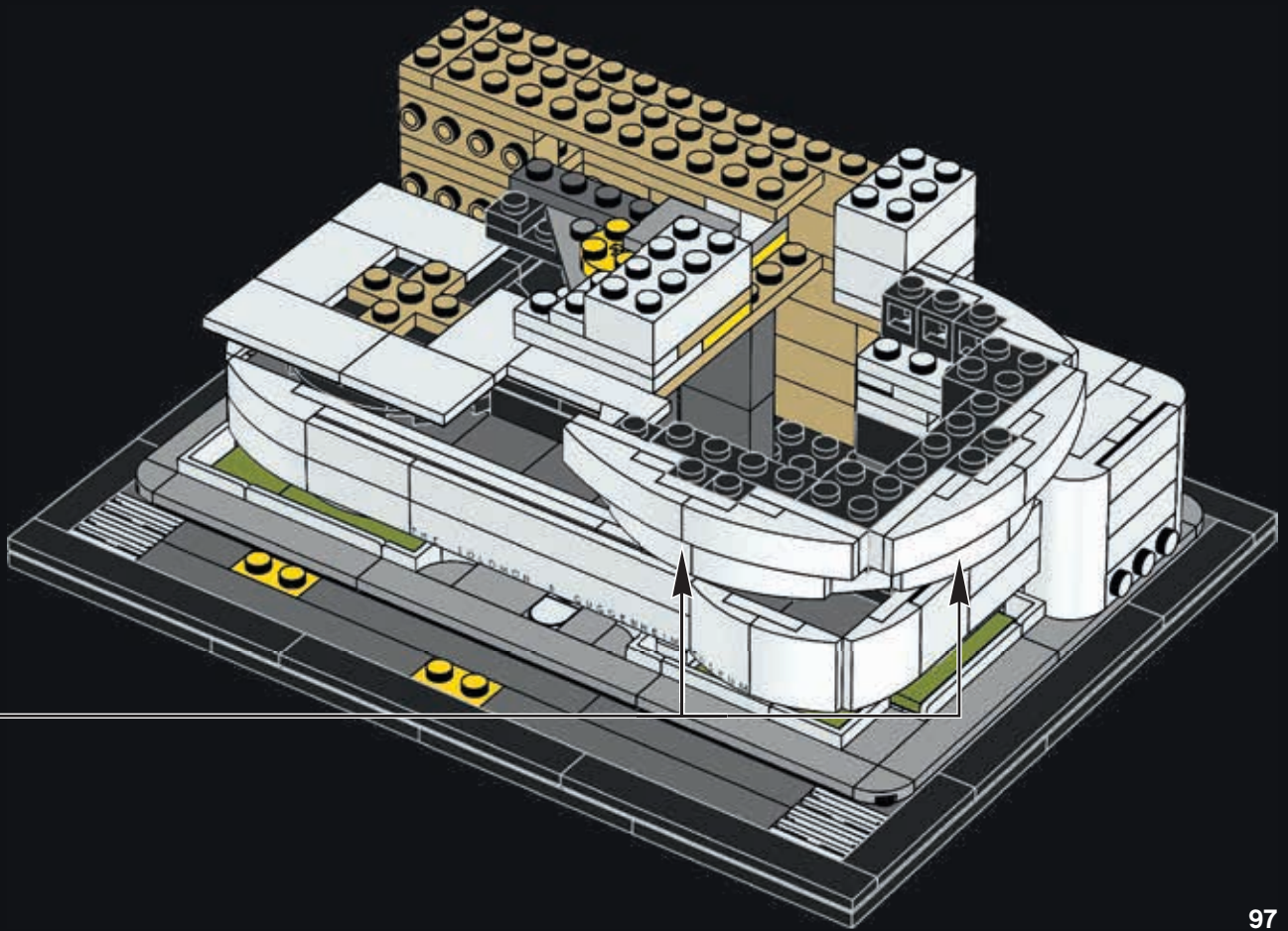



1x

92

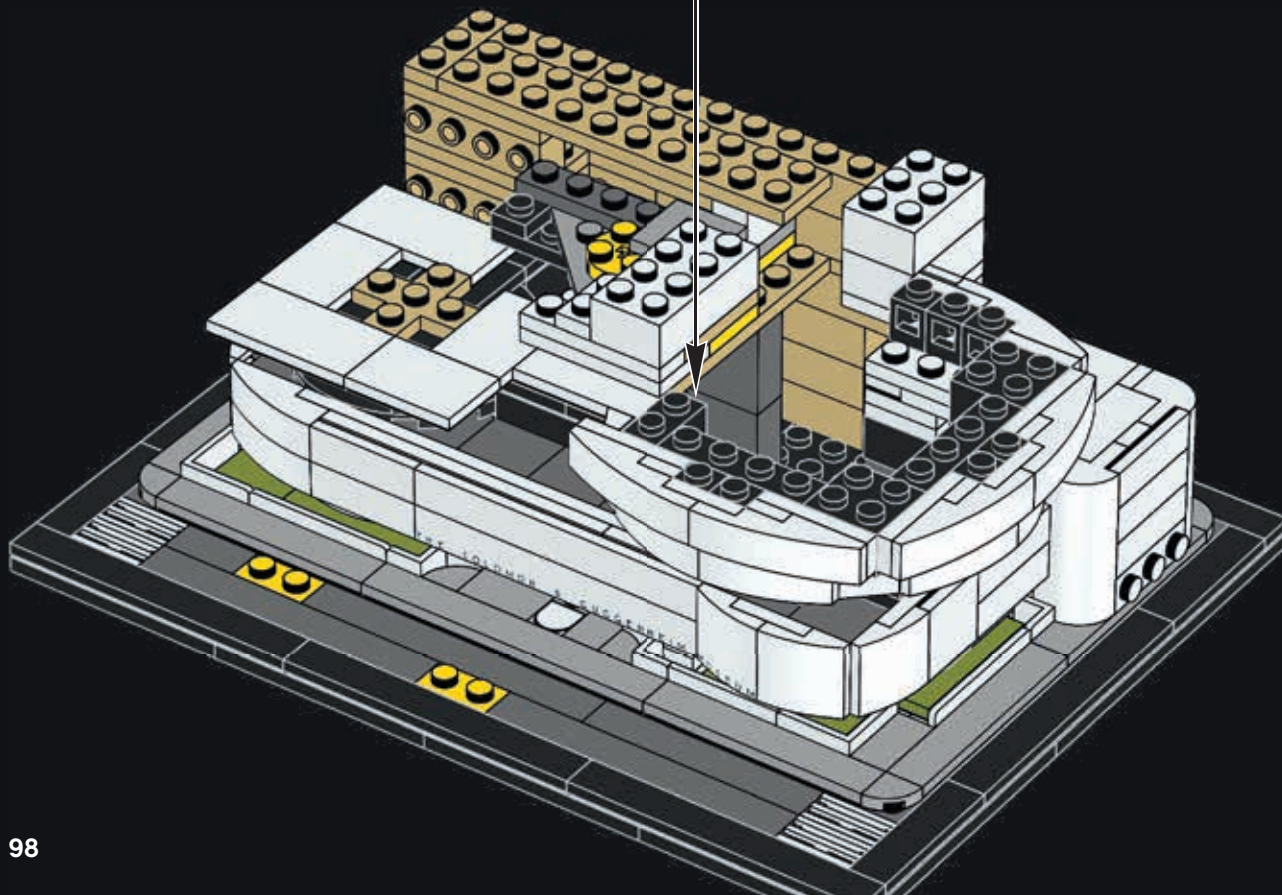

98



93

1



2



3



4

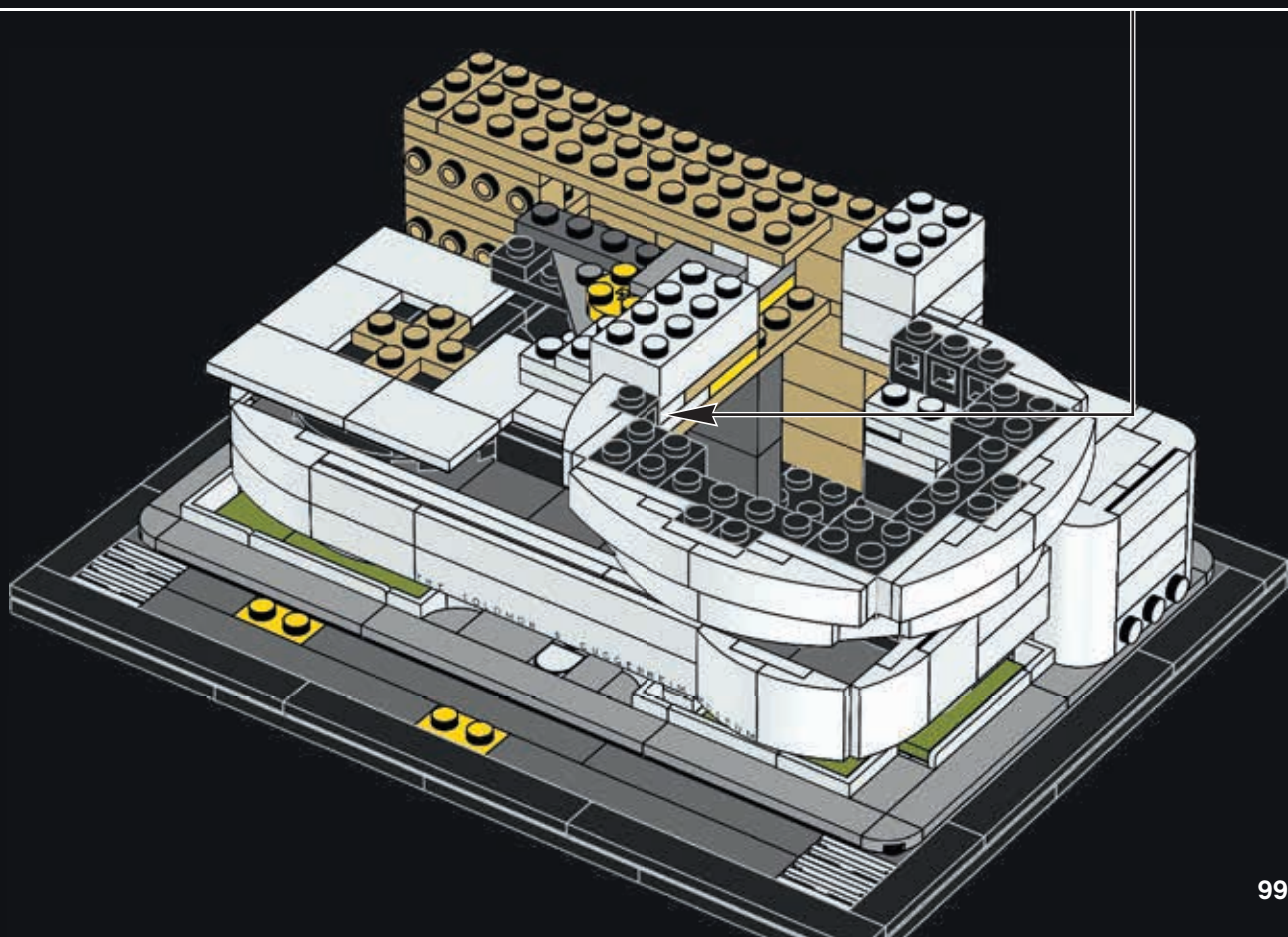
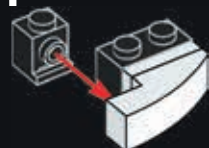



94

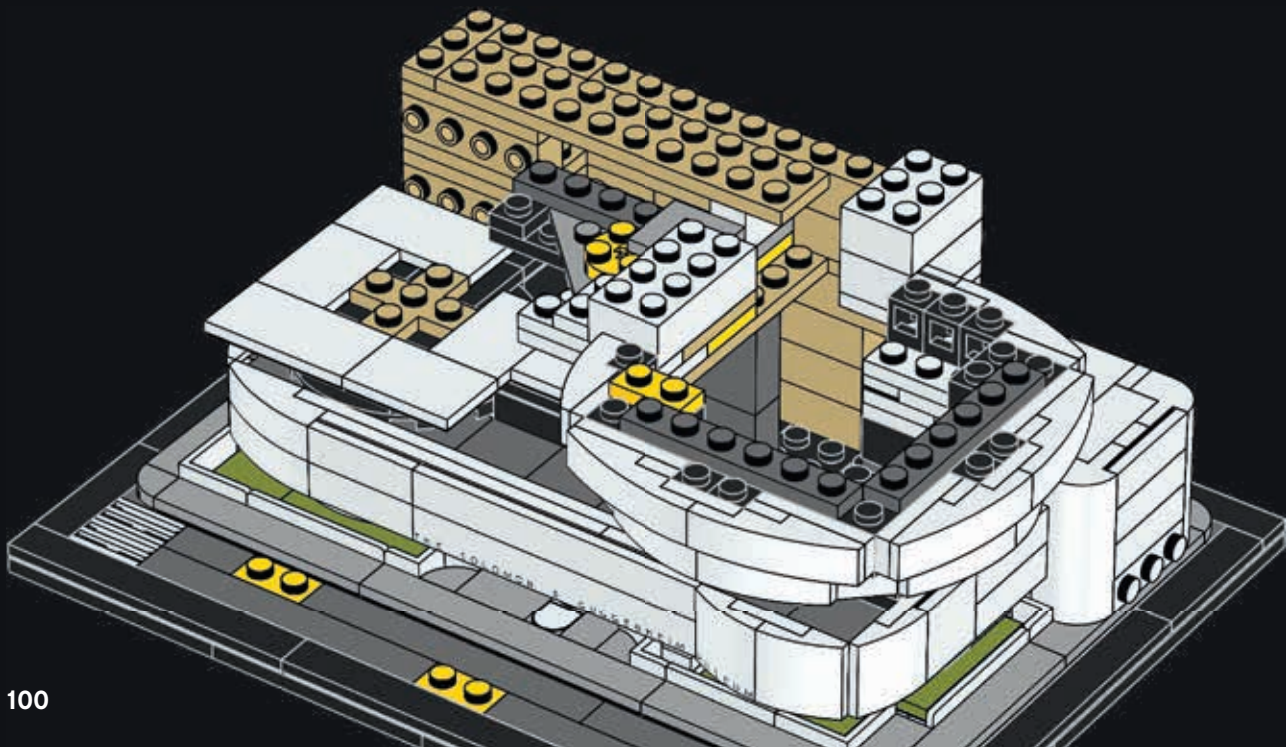

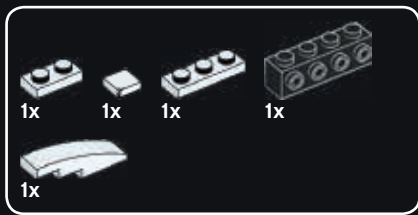

95

1

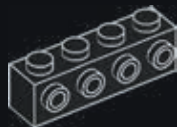

2



3



4

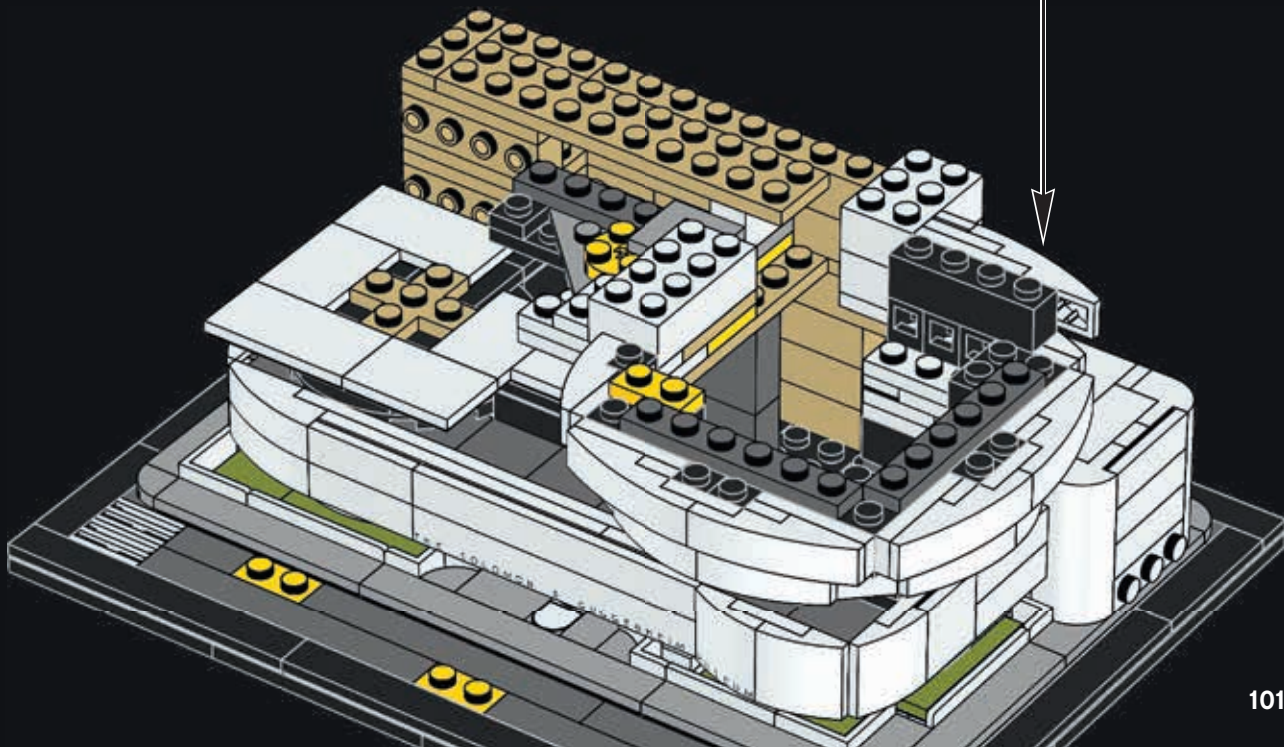



2x



1x

96

1

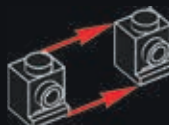

2

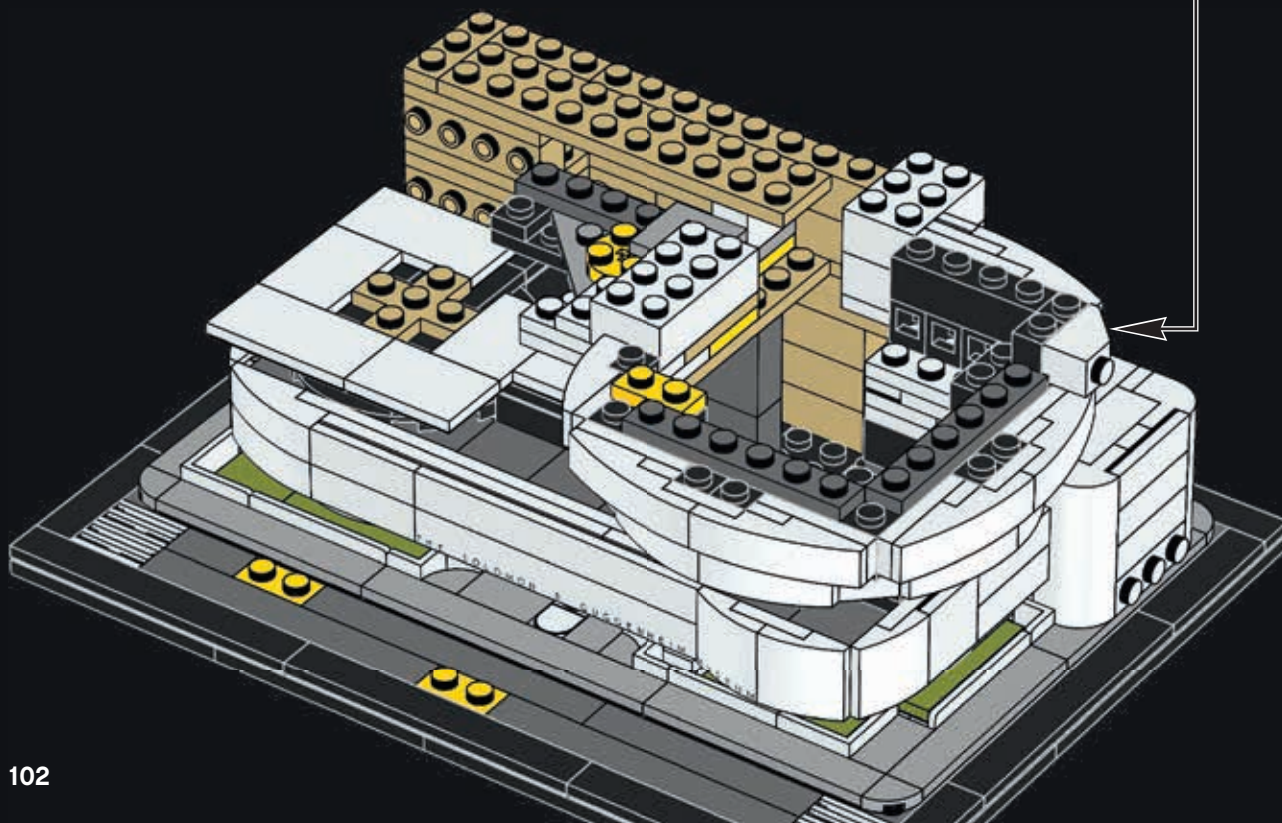

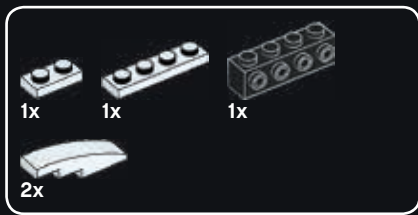

97

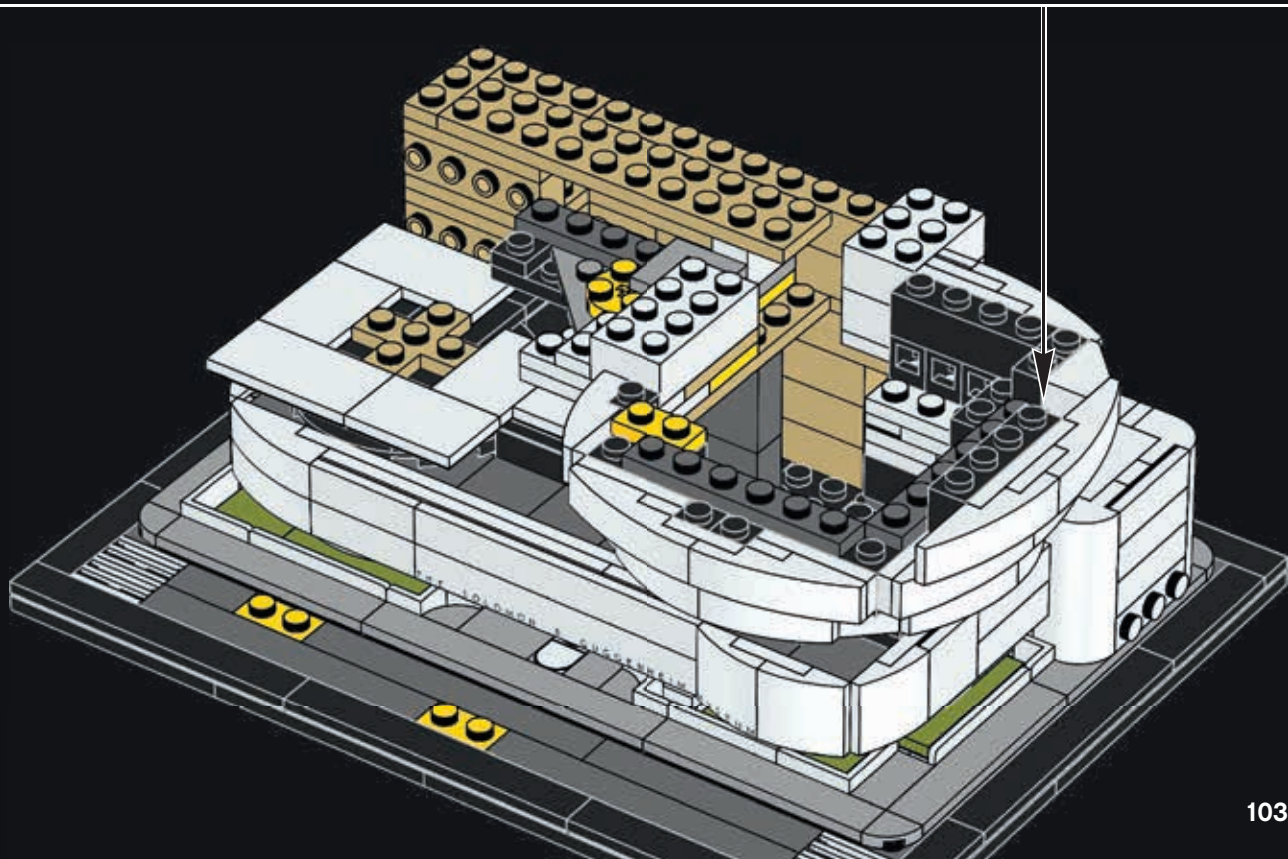



2x



1x

98

1

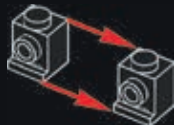

2

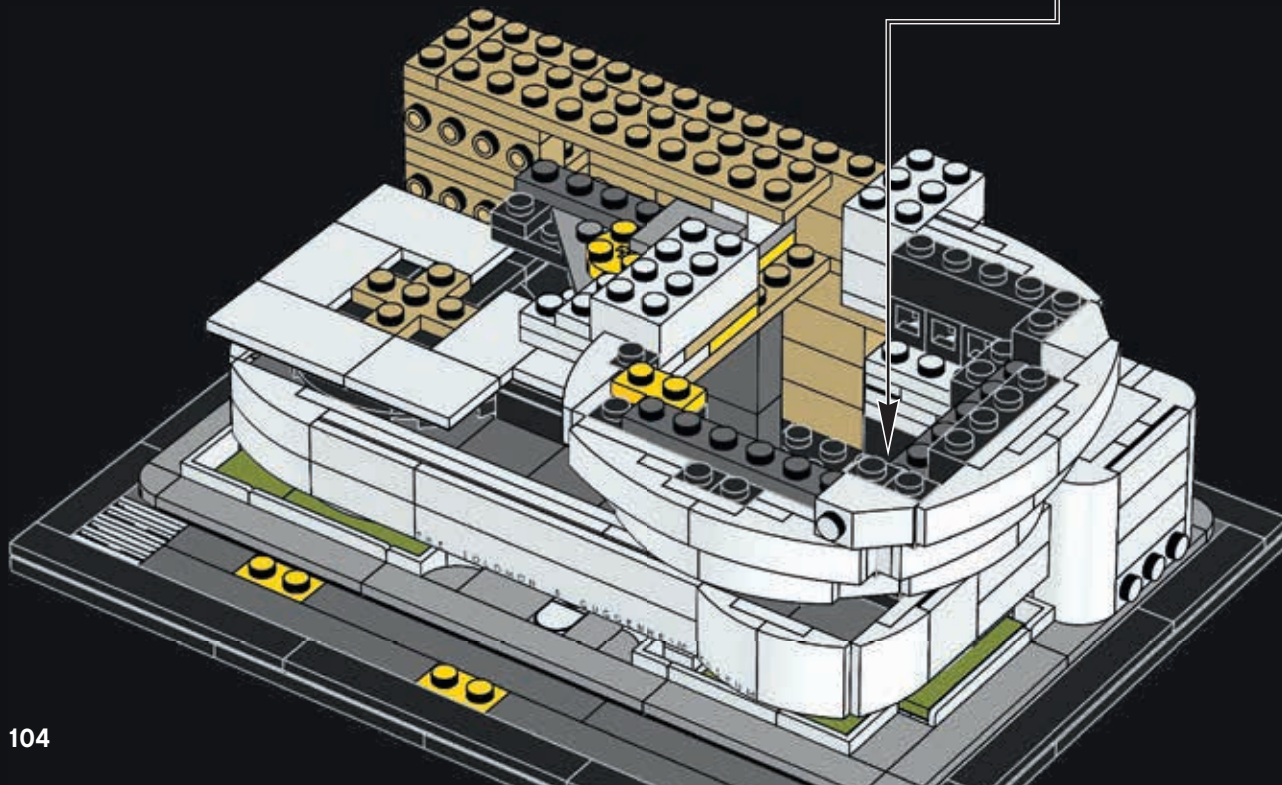

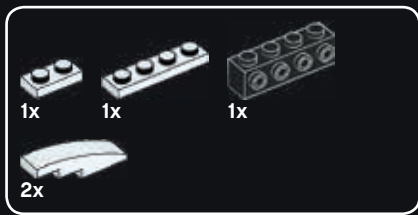

99

1

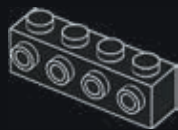

2

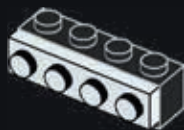

3



4

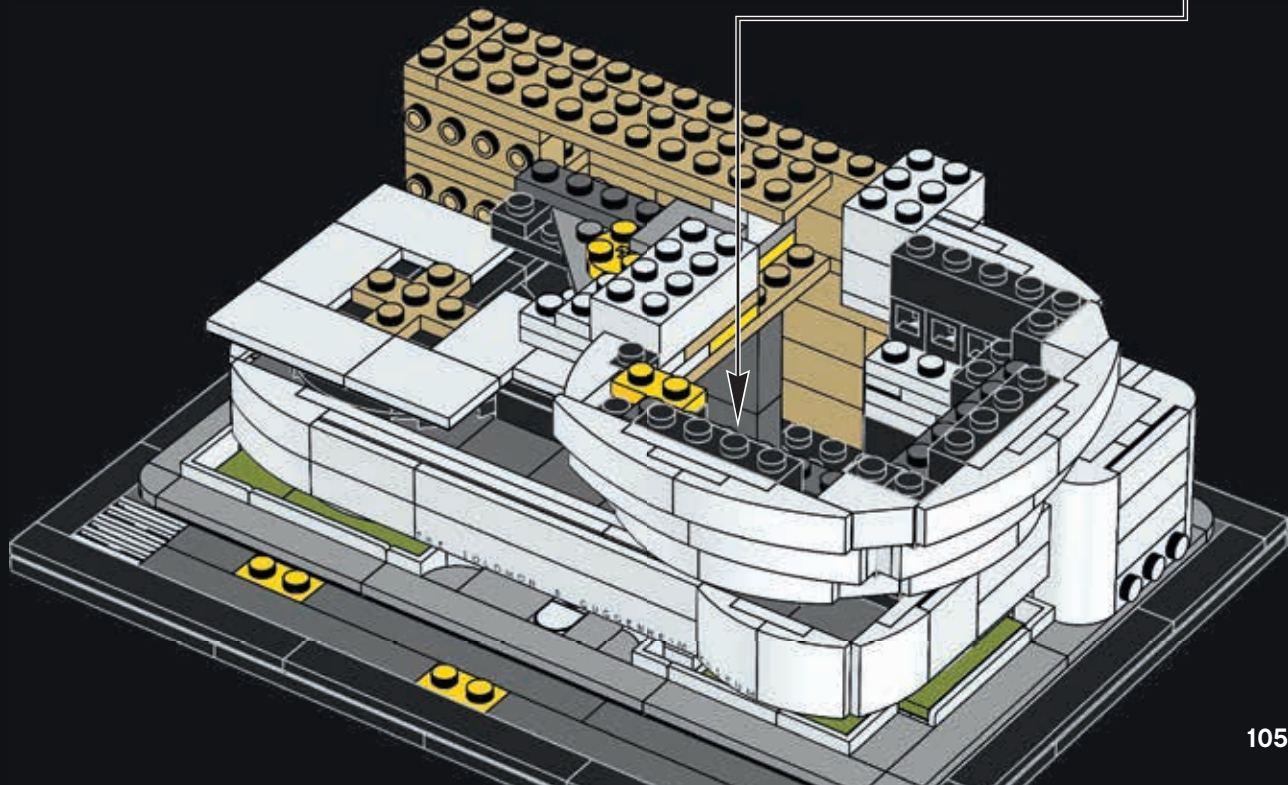

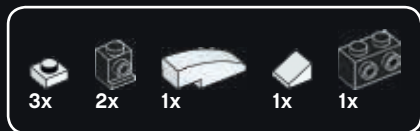

100

1



2



3



4



5

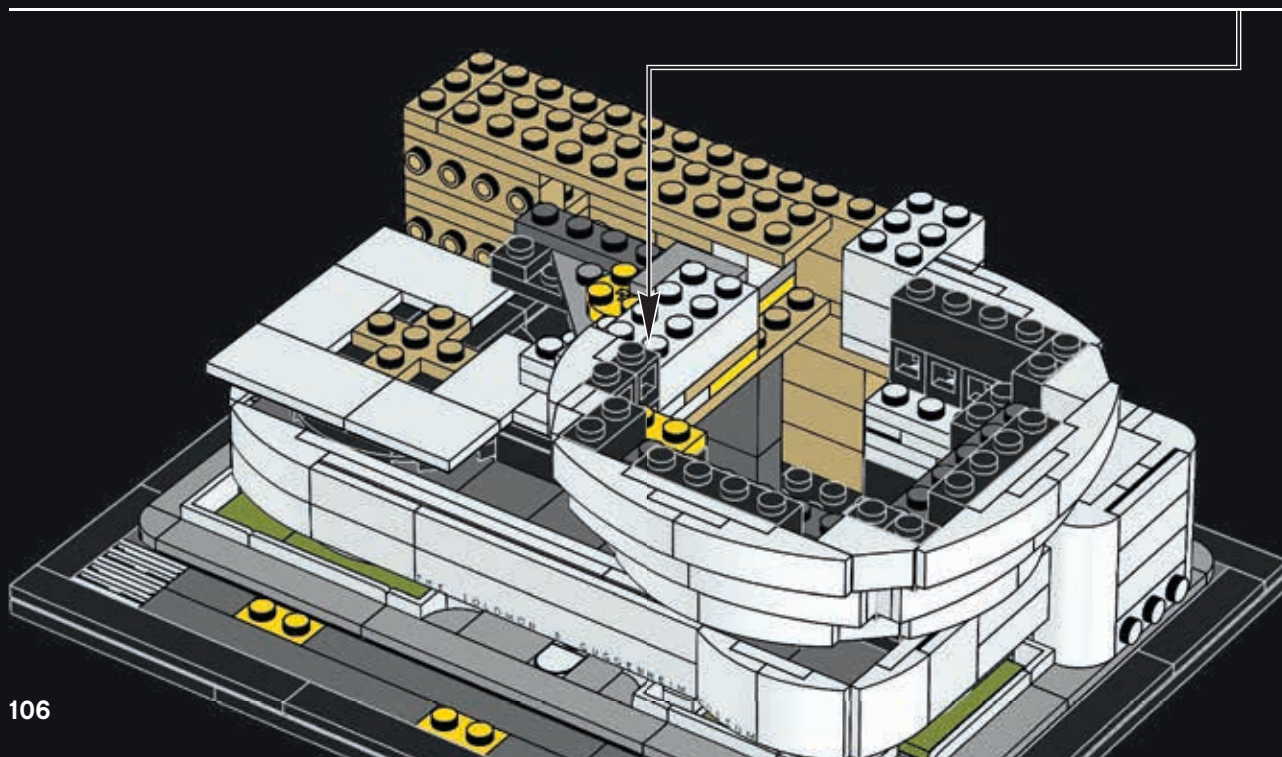
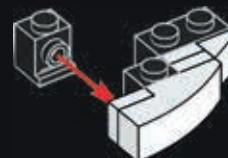

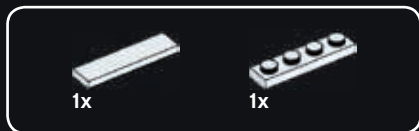

101

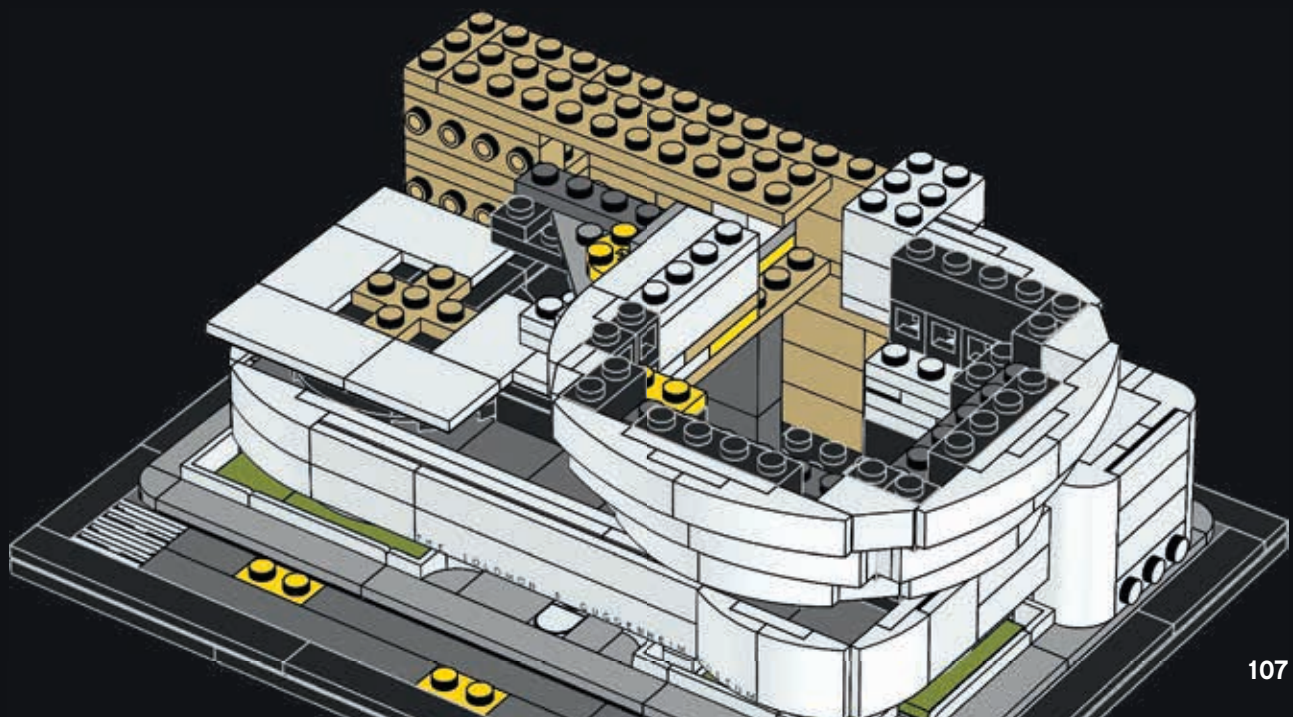



102

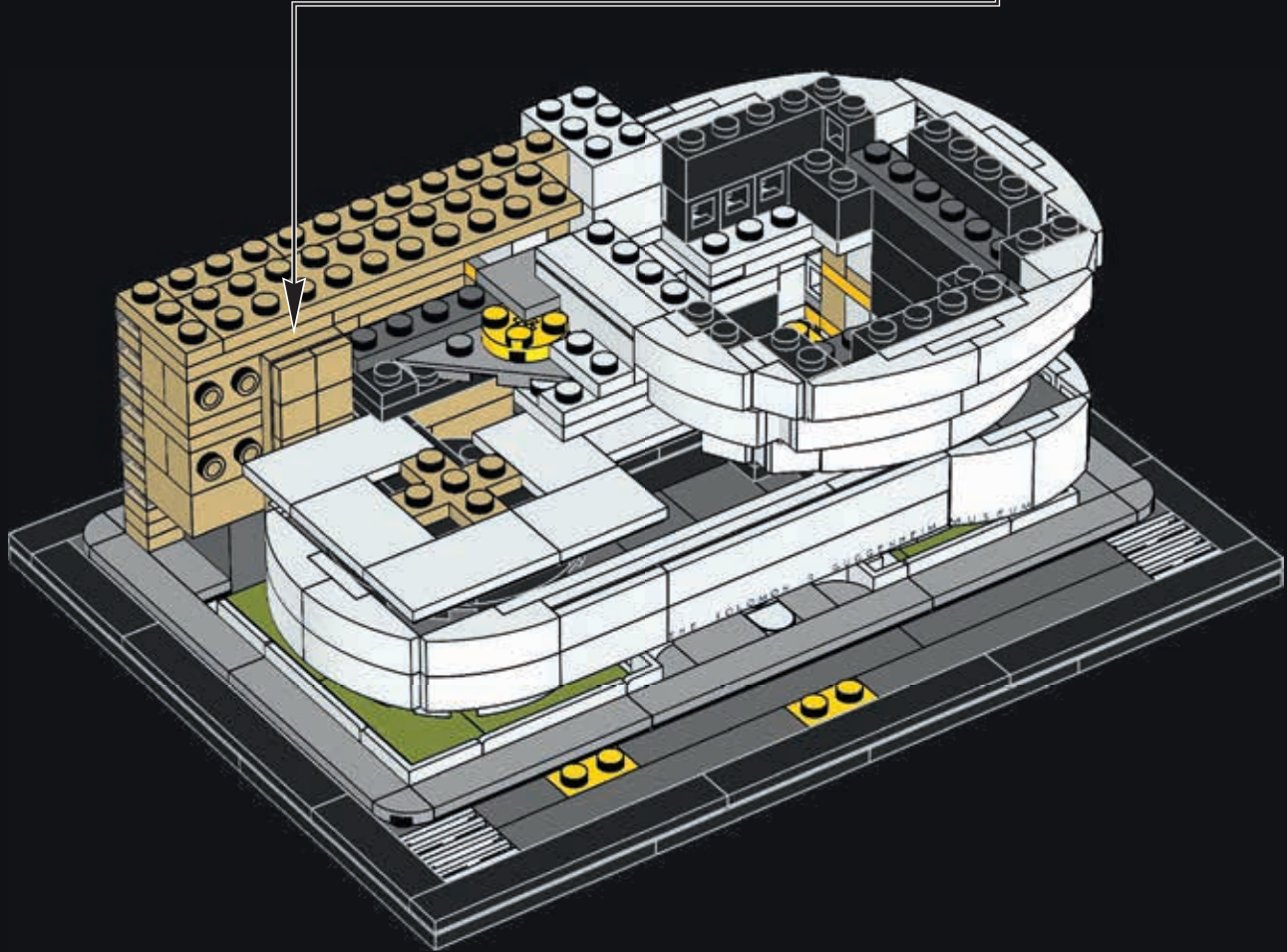
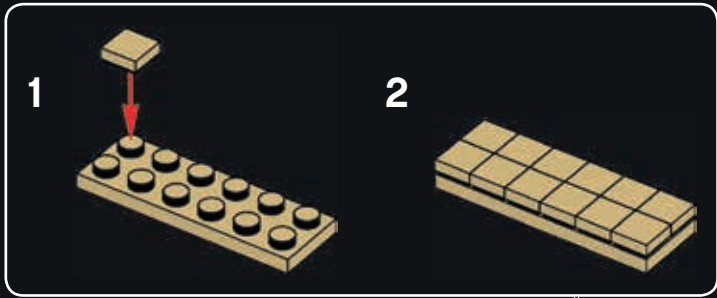

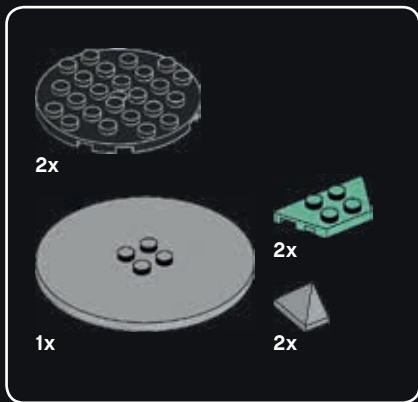

103

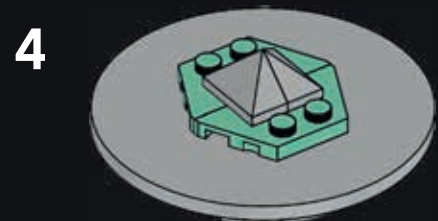
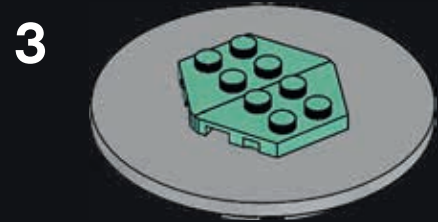
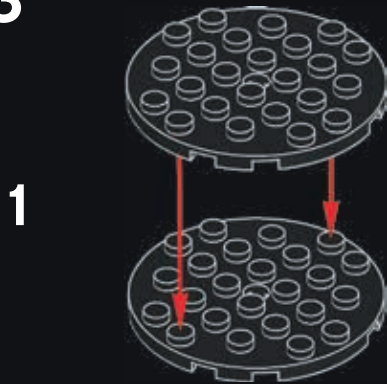

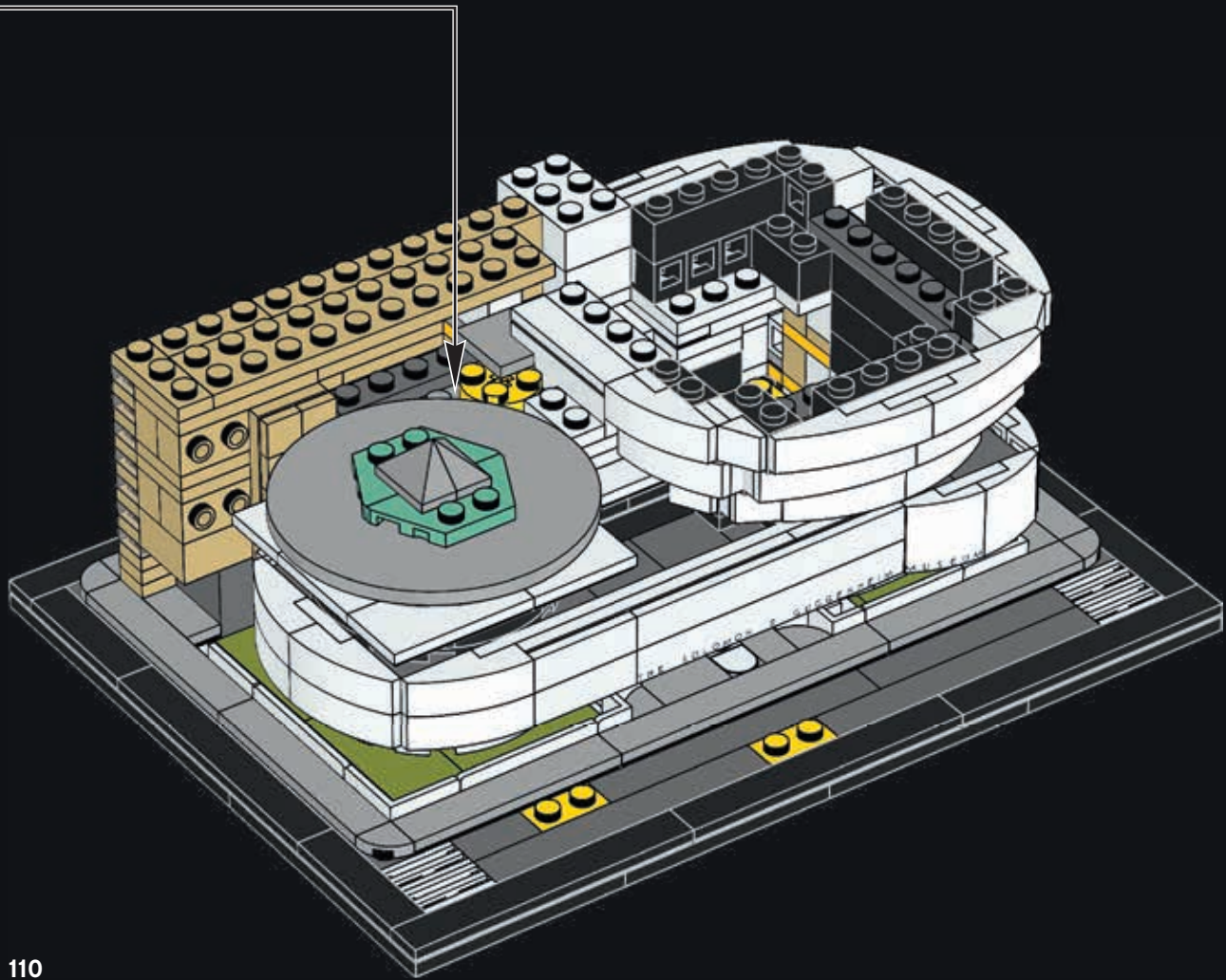



104

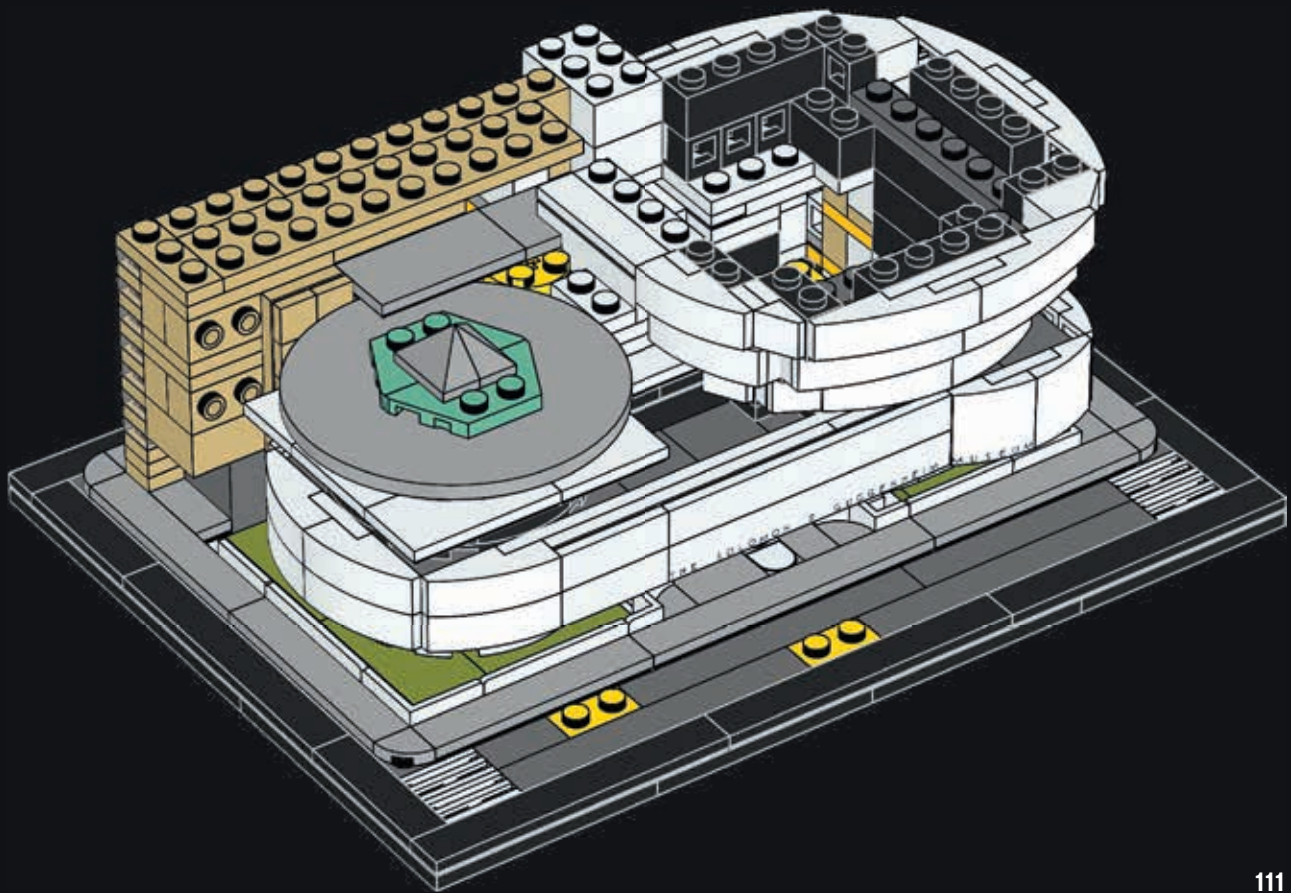



1x

105

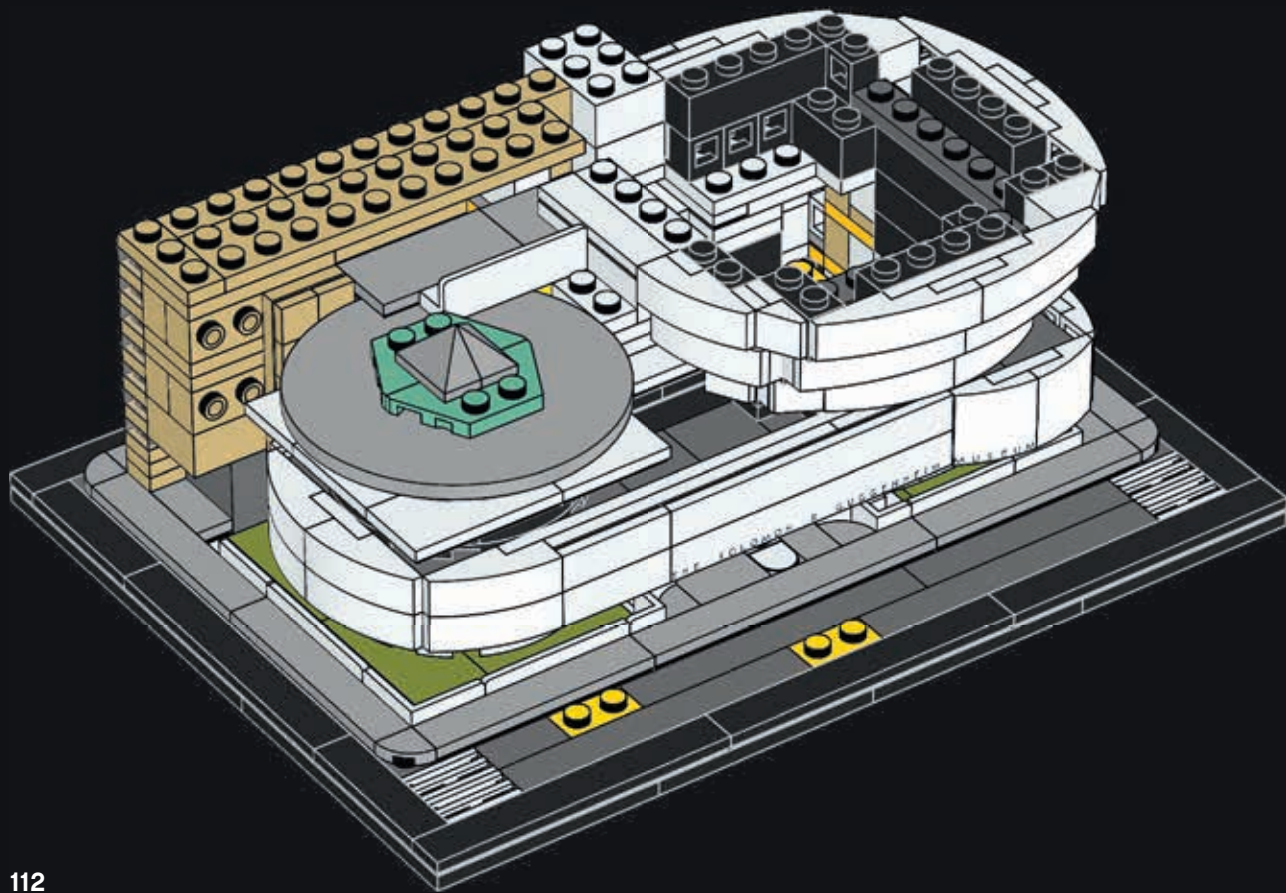



106

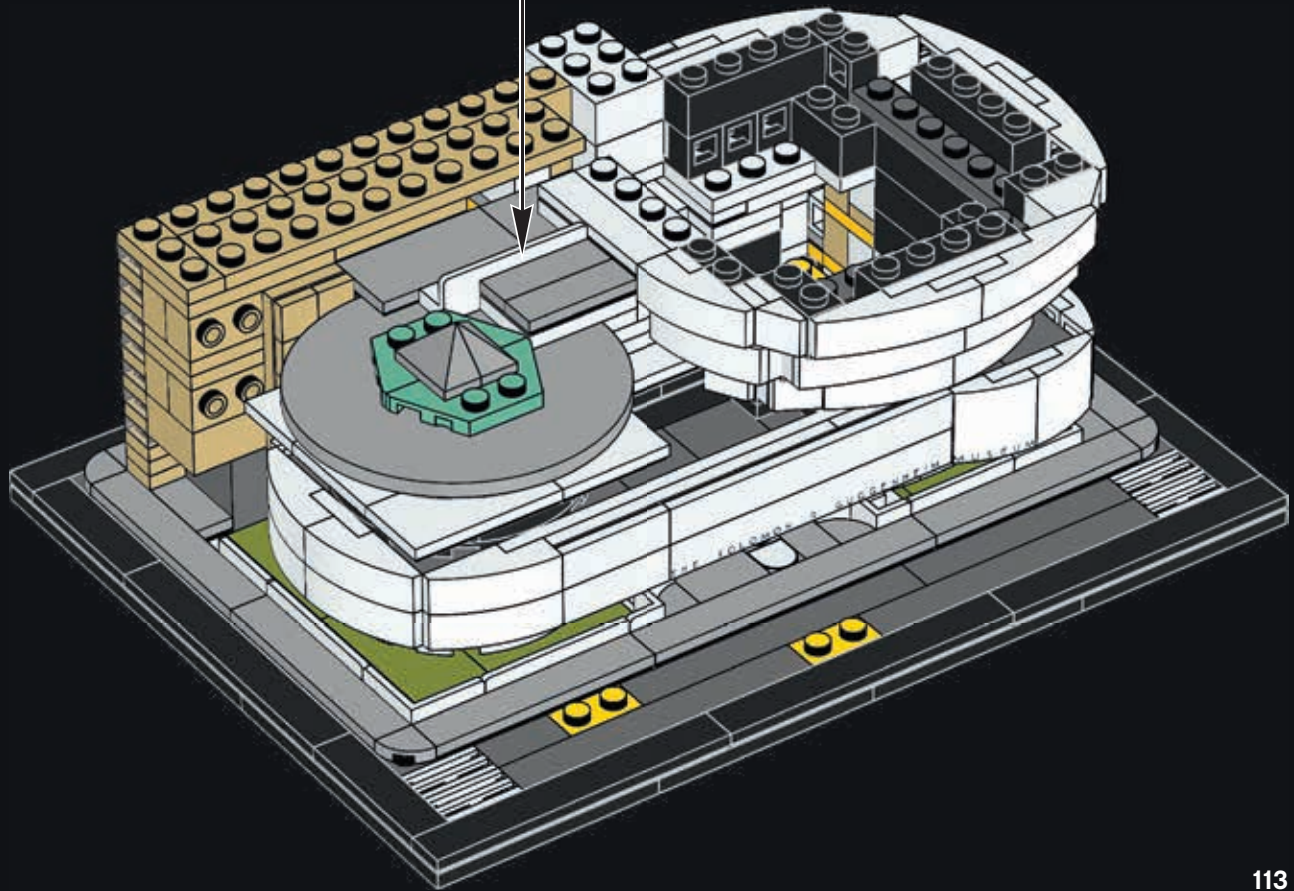



107

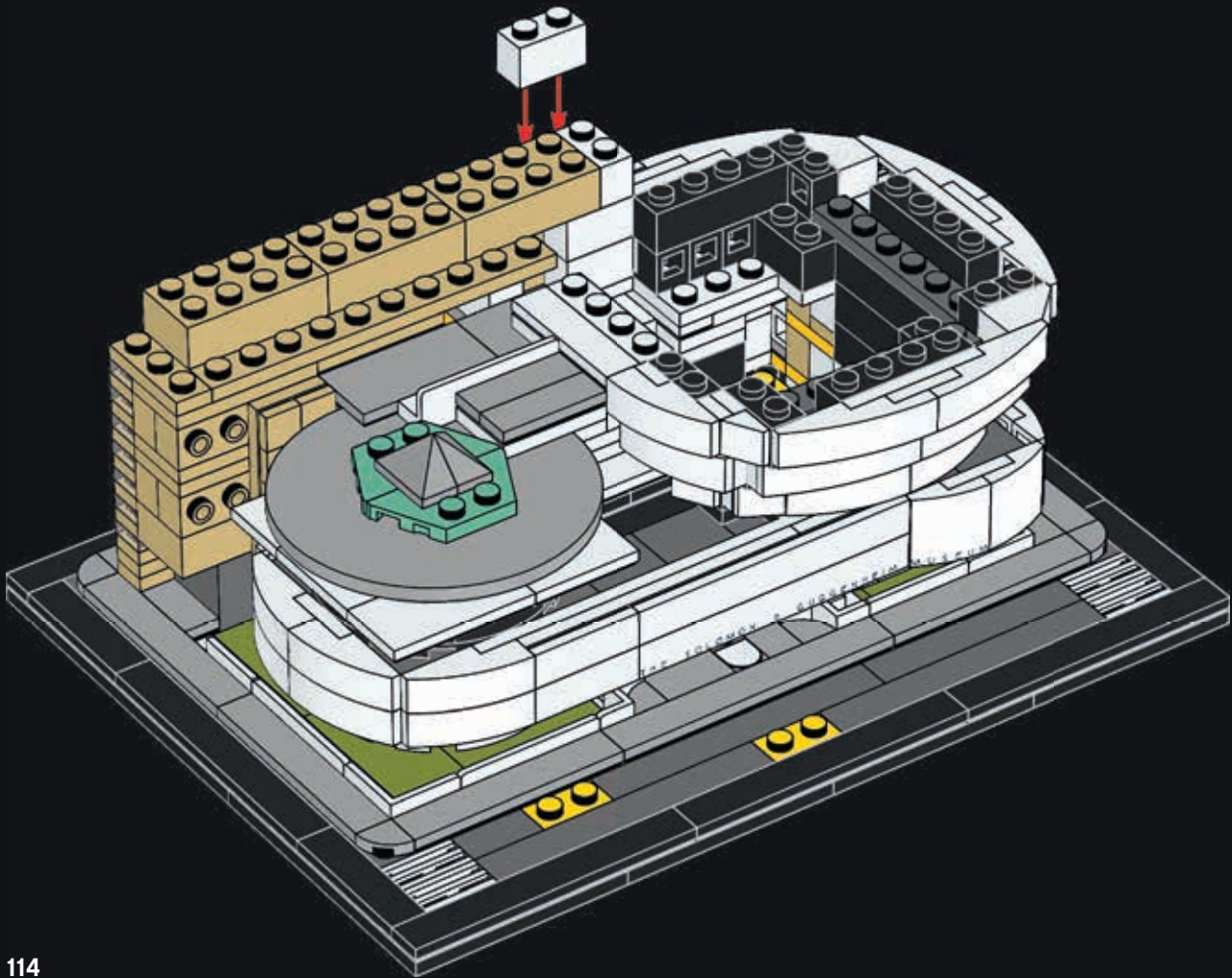



1x



1x



2x

108

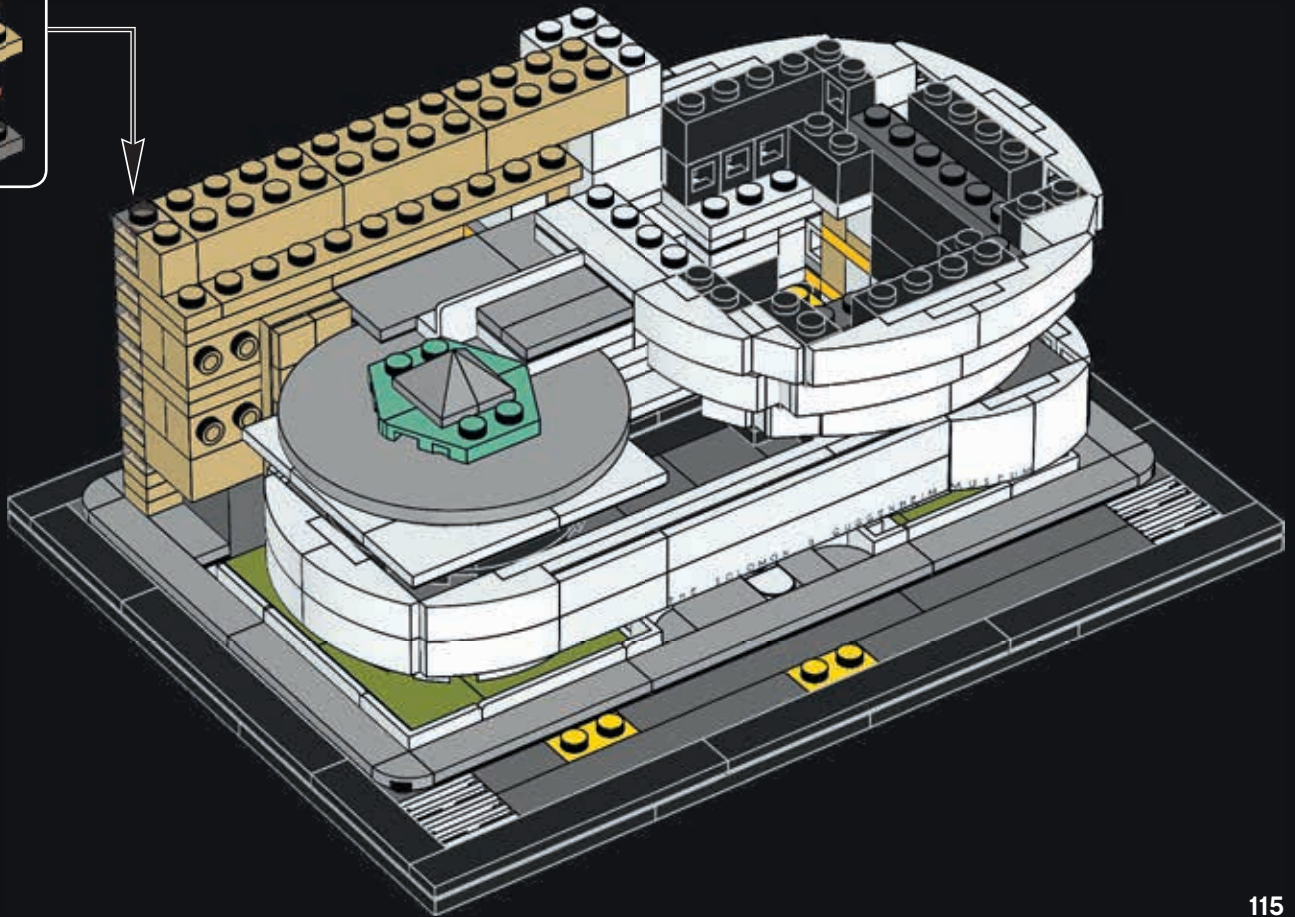



109

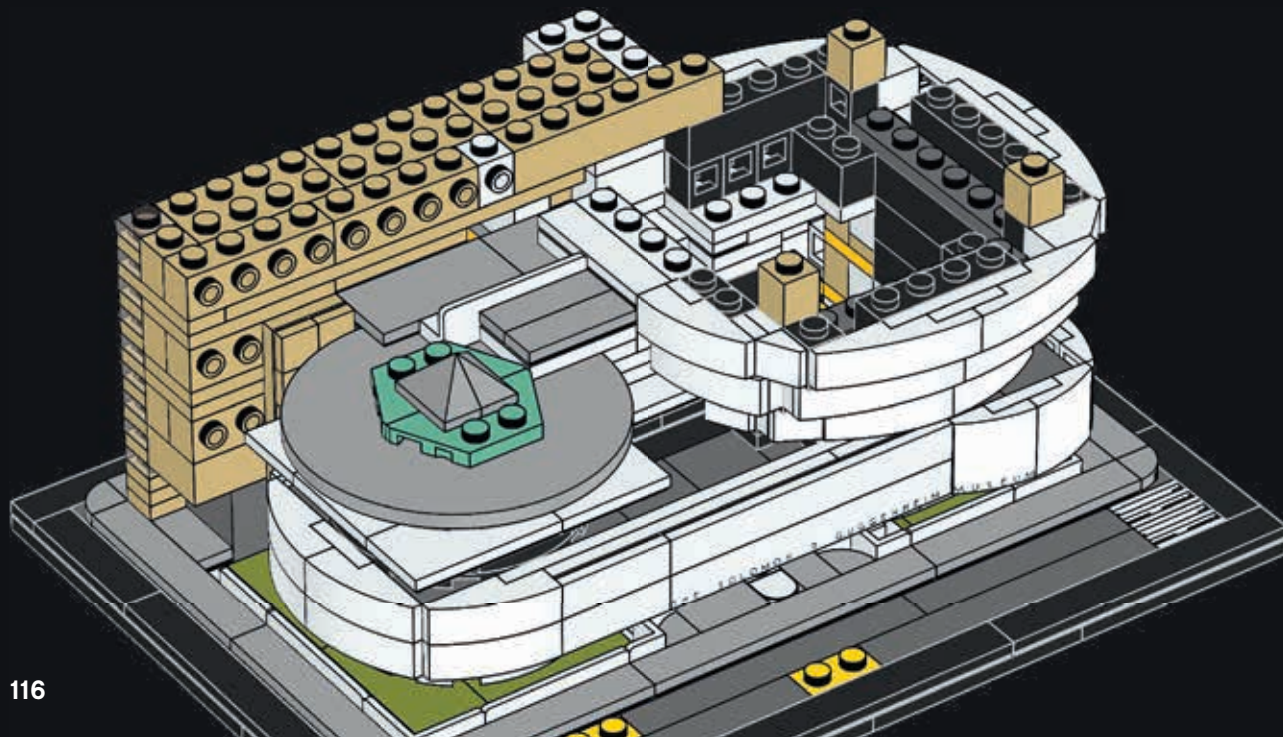

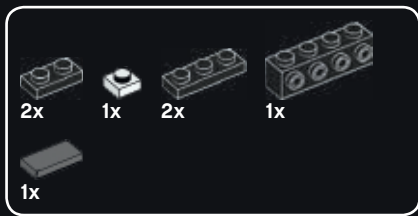

110

1



2

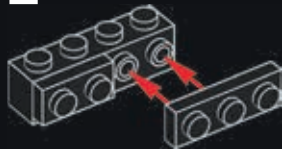

3

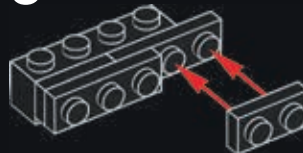

4

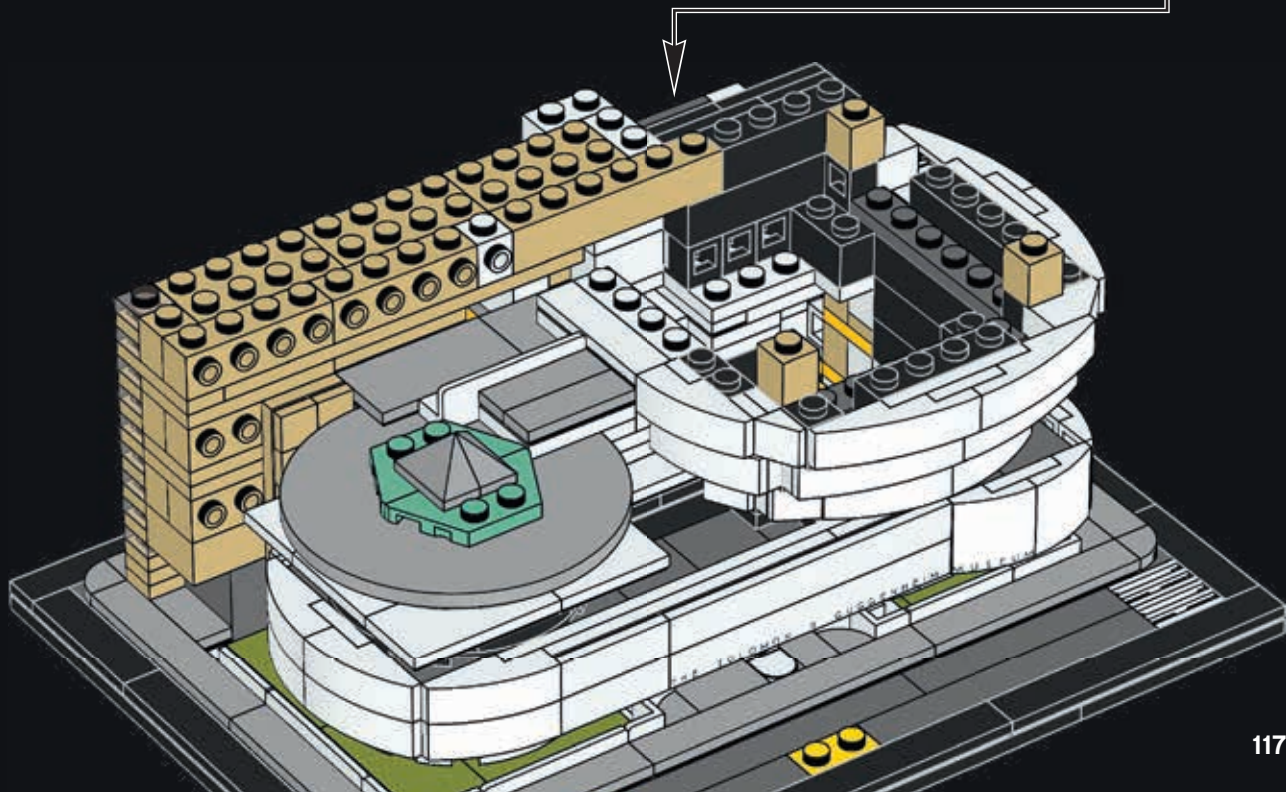
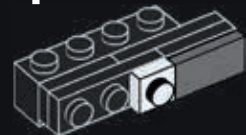



2x



111

1

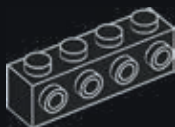

2

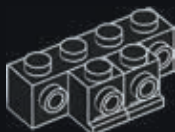

3

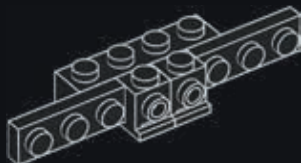

4

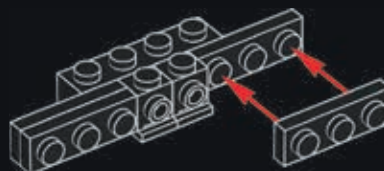

5

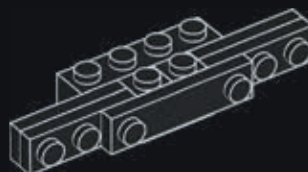

6

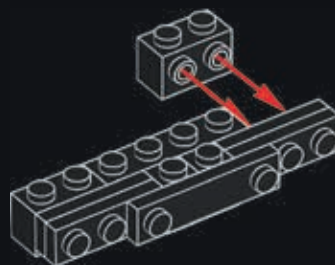

2x

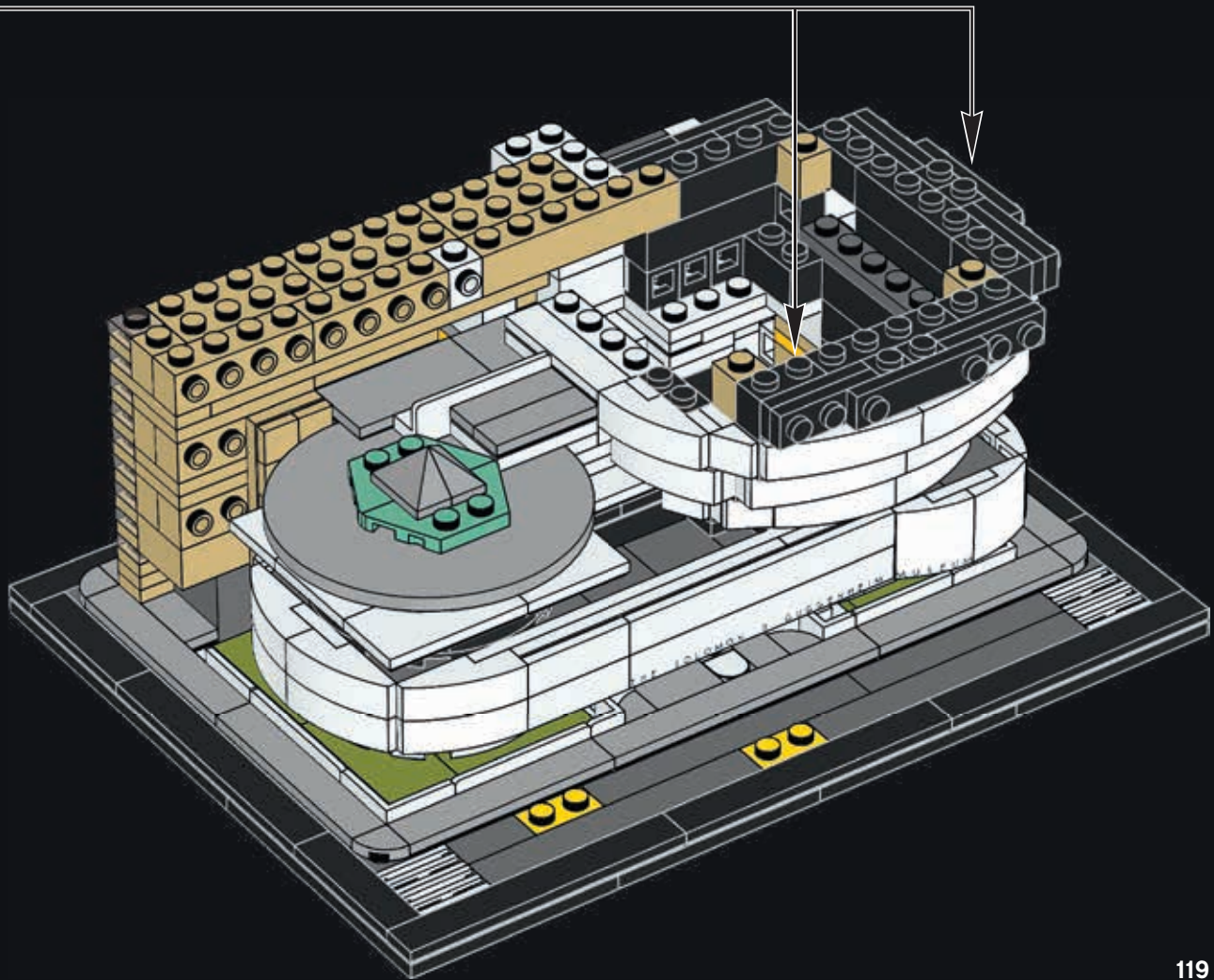



112

1

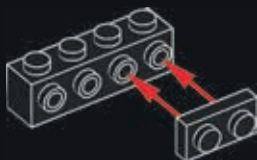

2

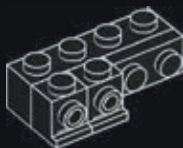

3

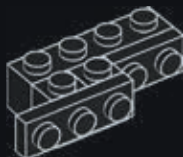

4

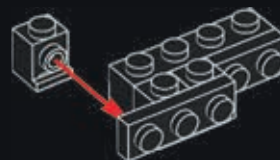

5

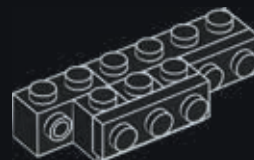

6

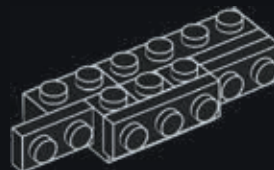

7

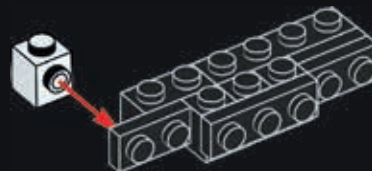

It took \$3 million to build the Guggenheim Museum between 1943-1959. The restoration of the exterior from 2005 to 2008 cost \$2 million.



©The Solomon R. Guggenheim Foundation, New York

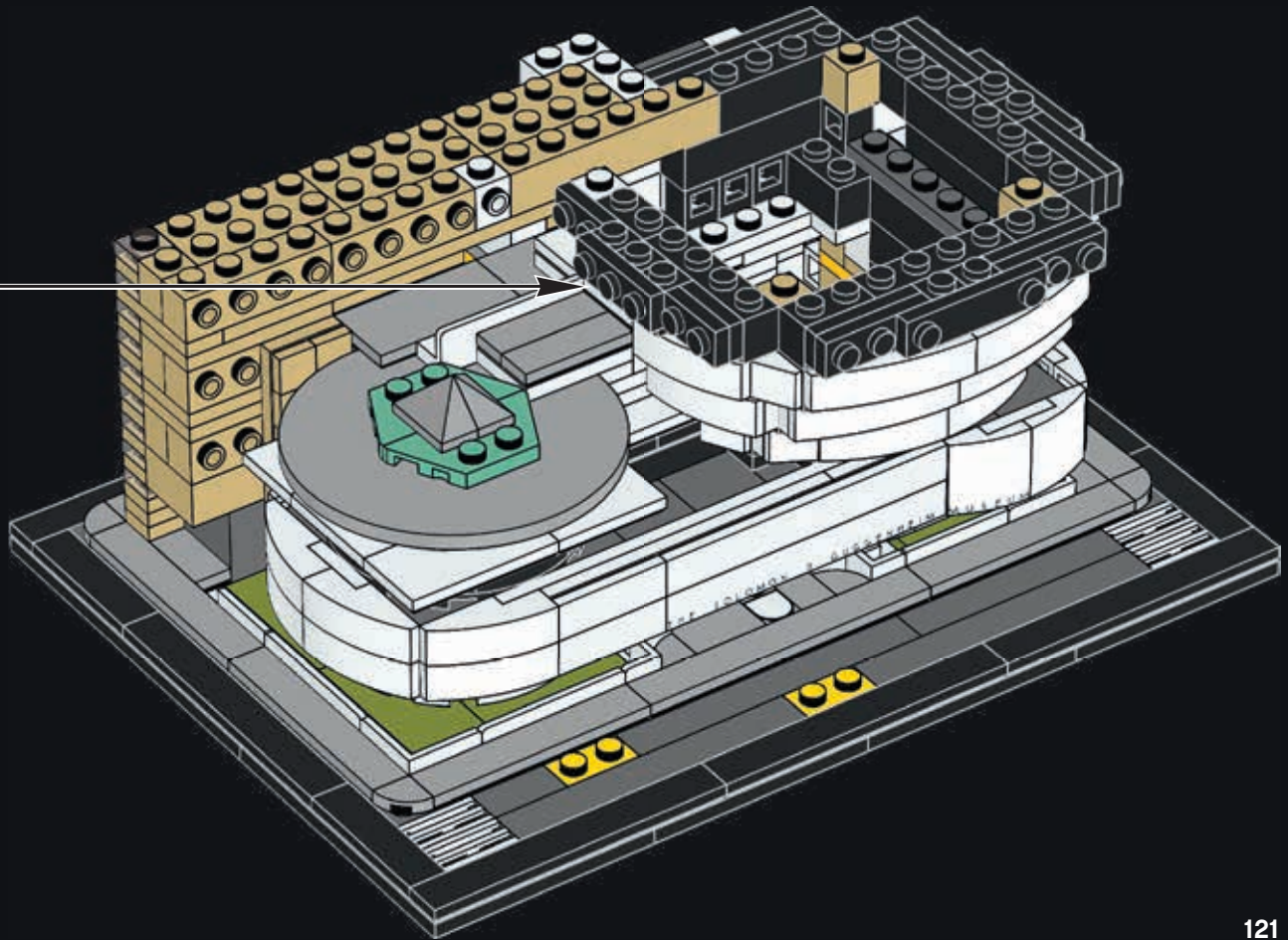



113

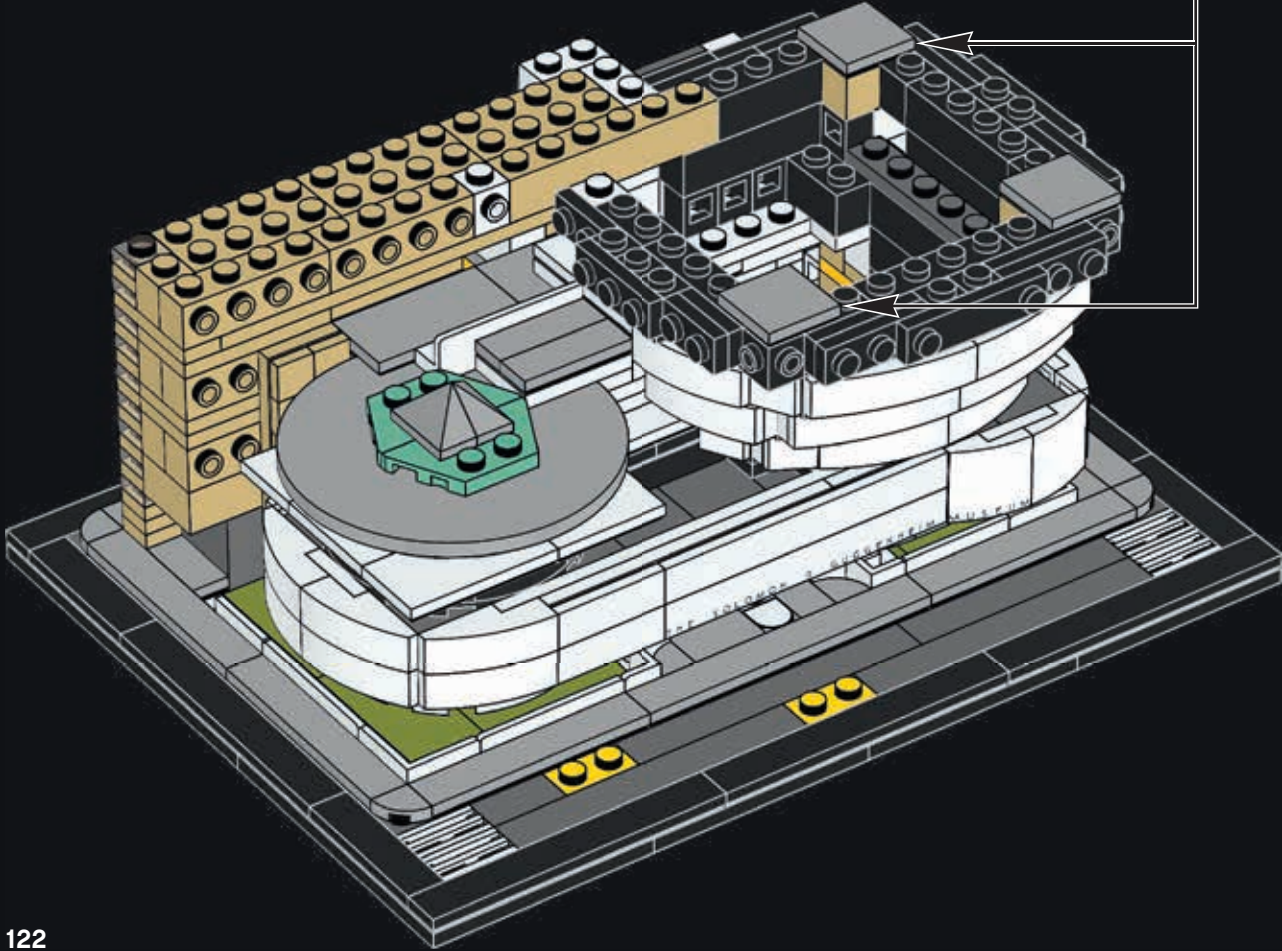

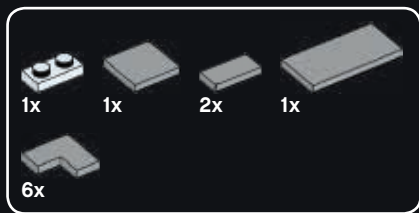

114

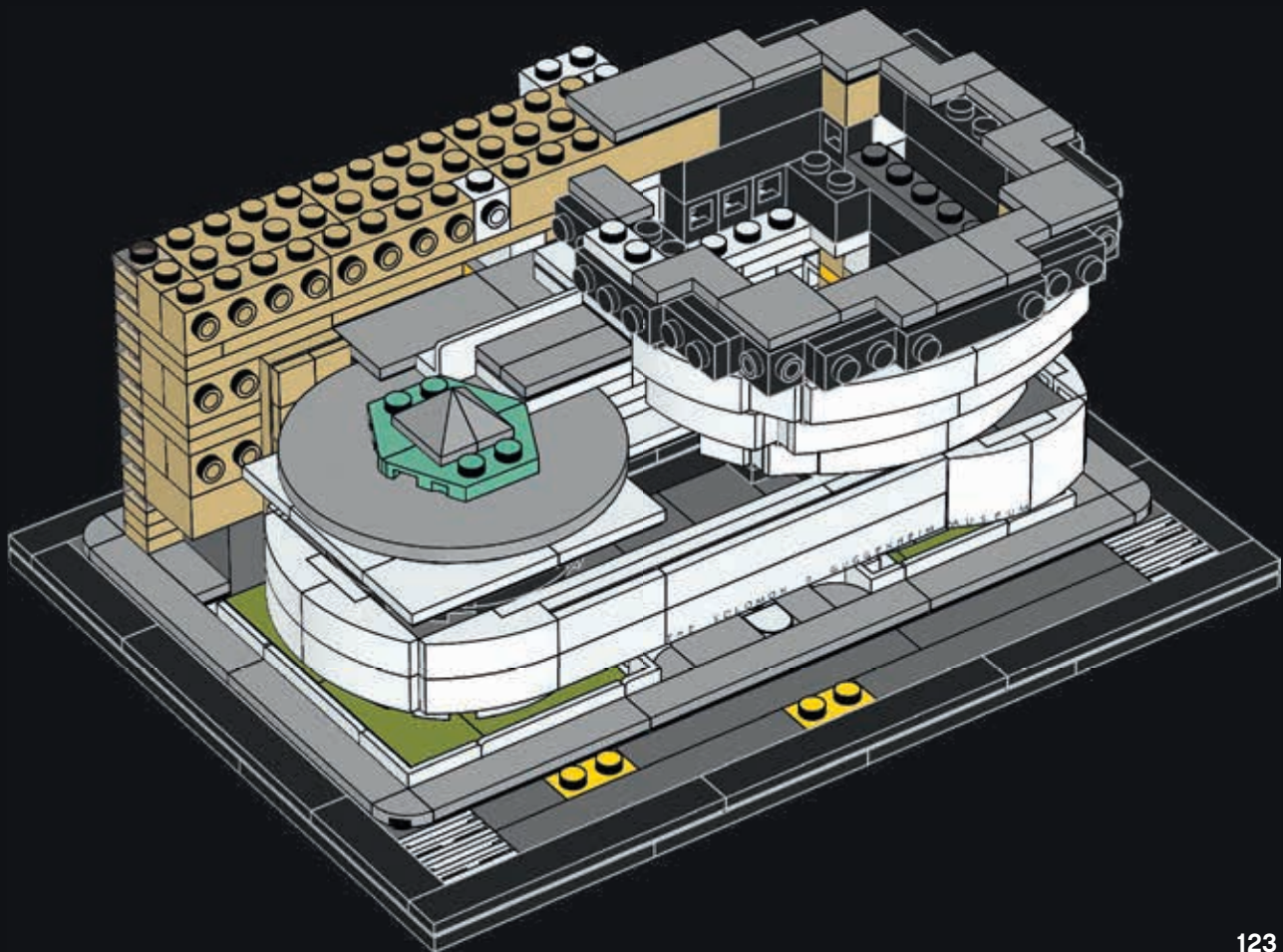



115

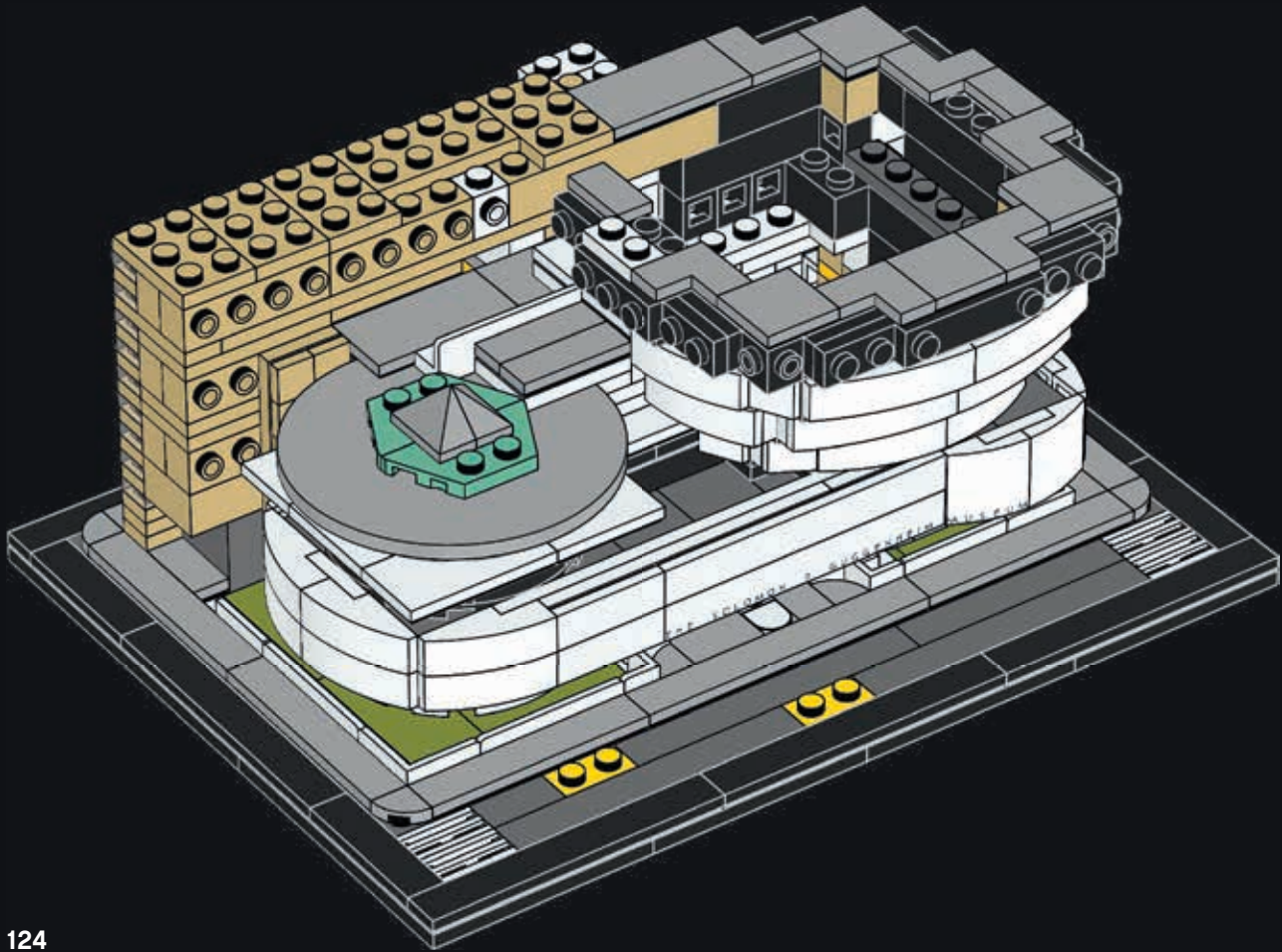



116

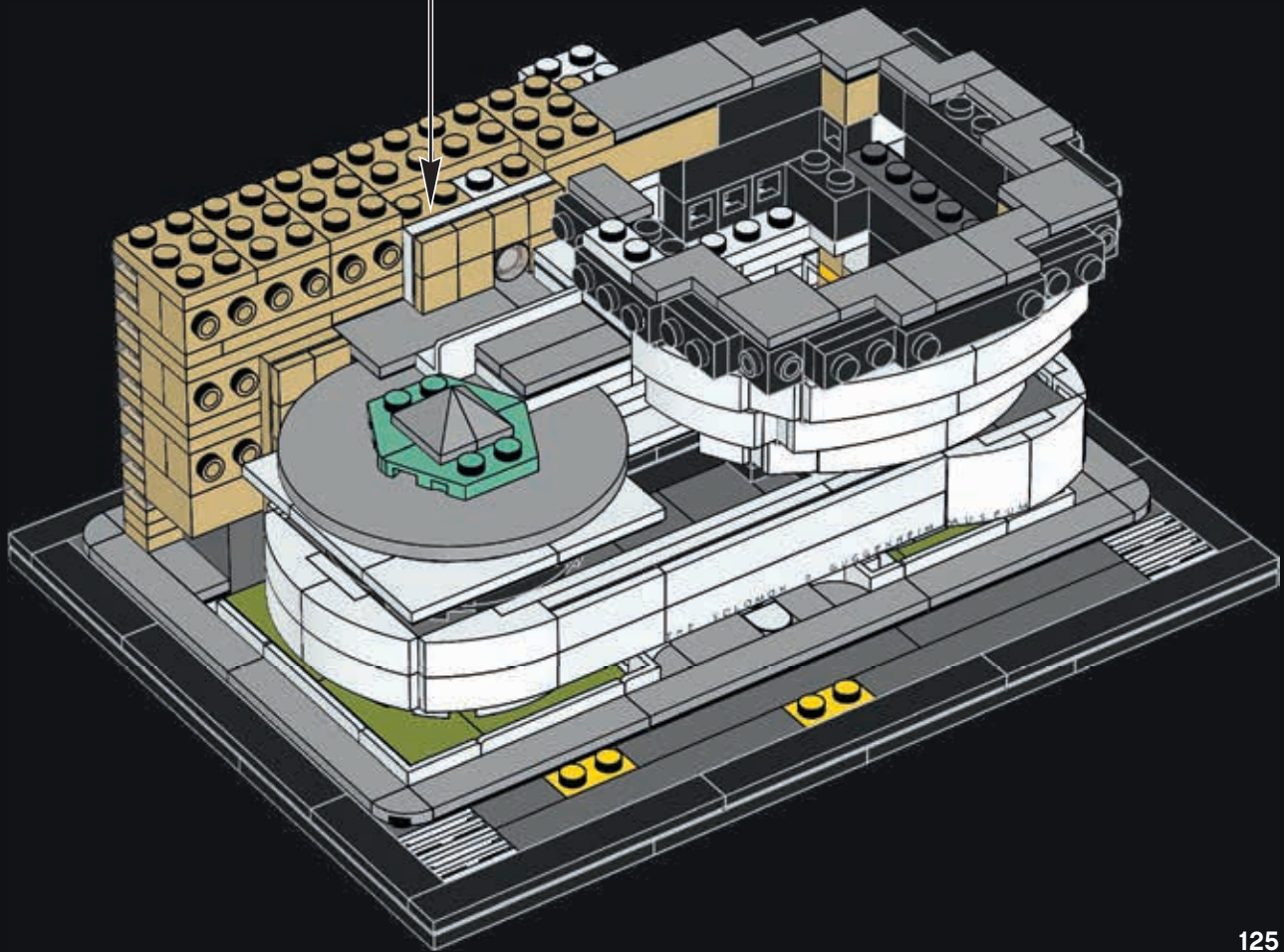
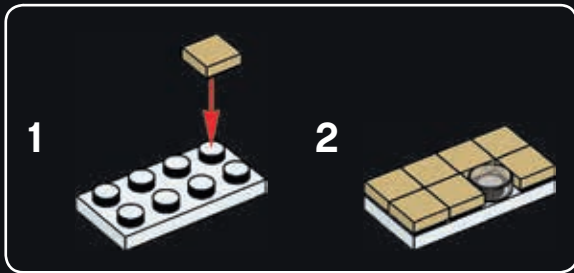



4x

117

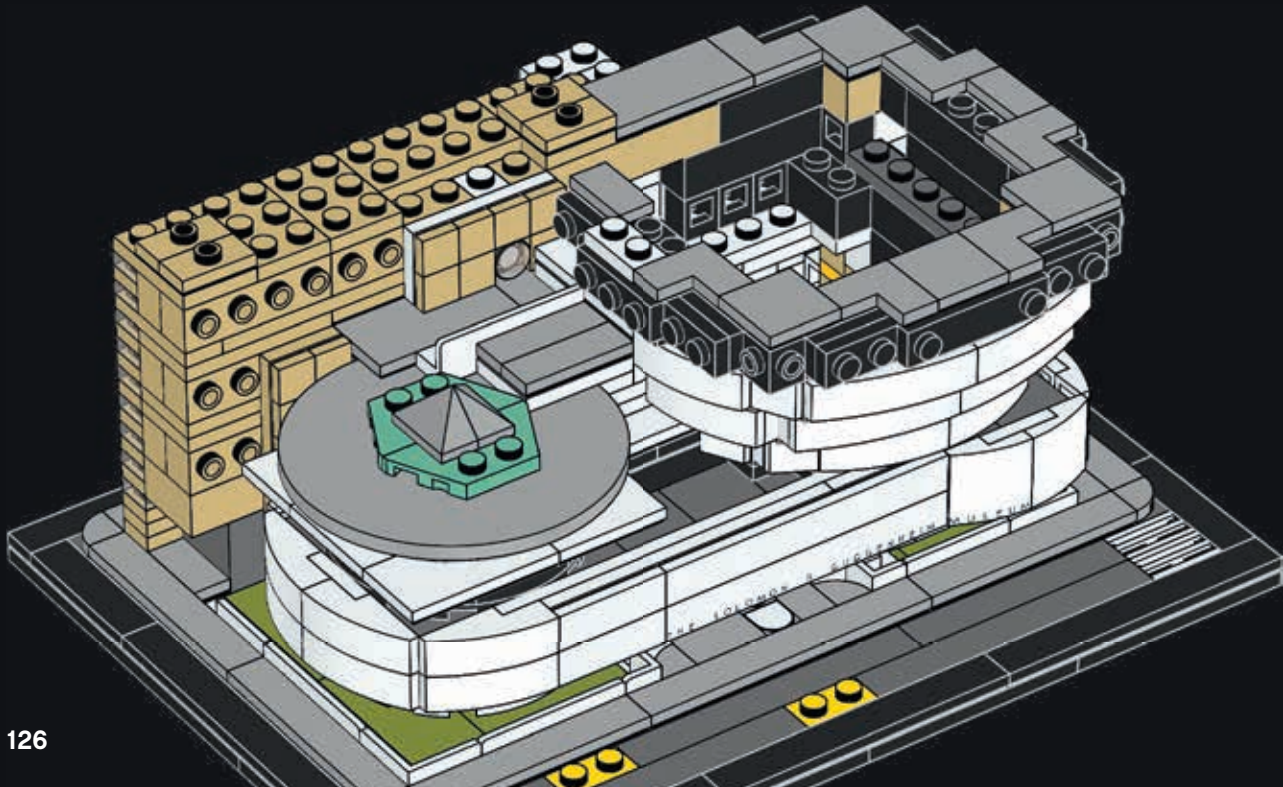

2x 3x 2x

118

1



2



3



4

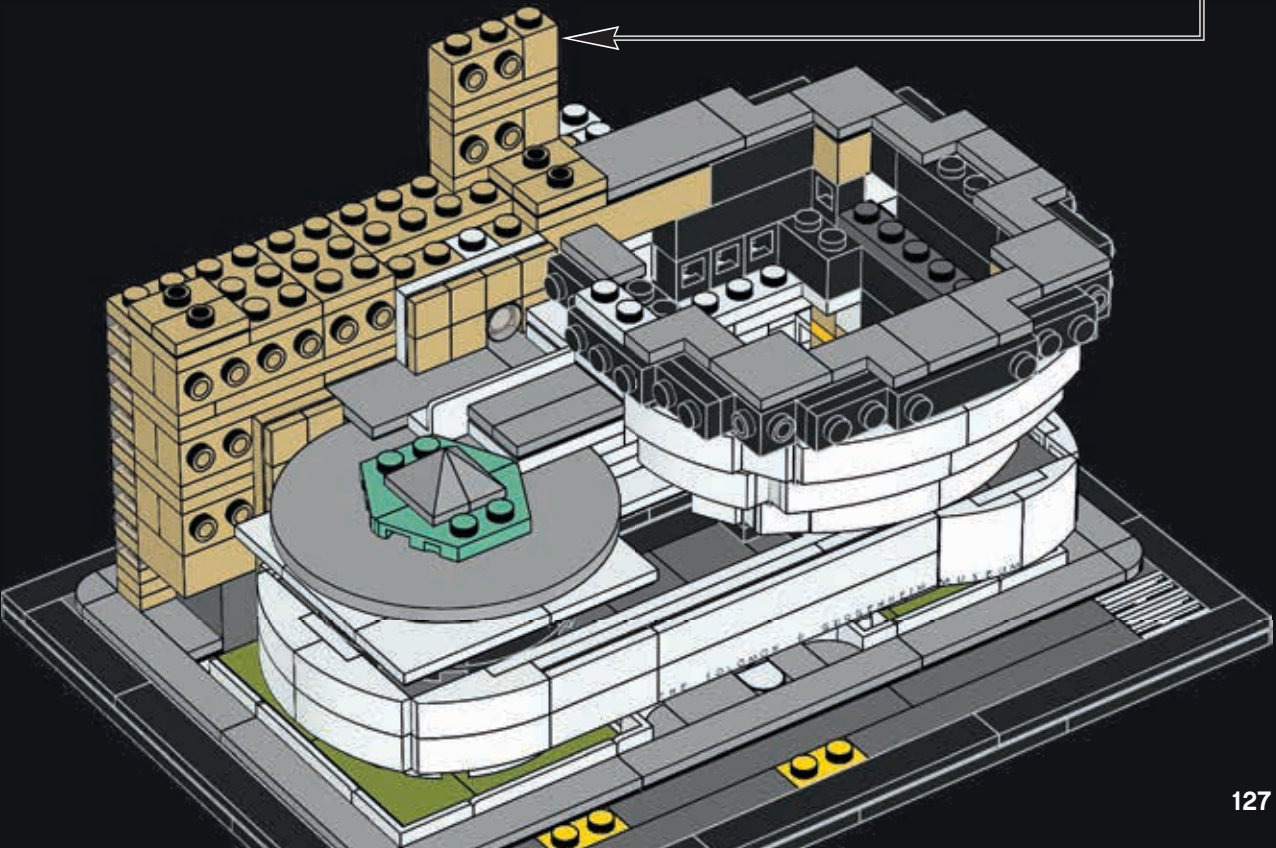



3x

119

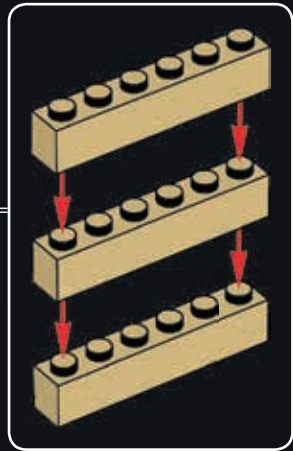
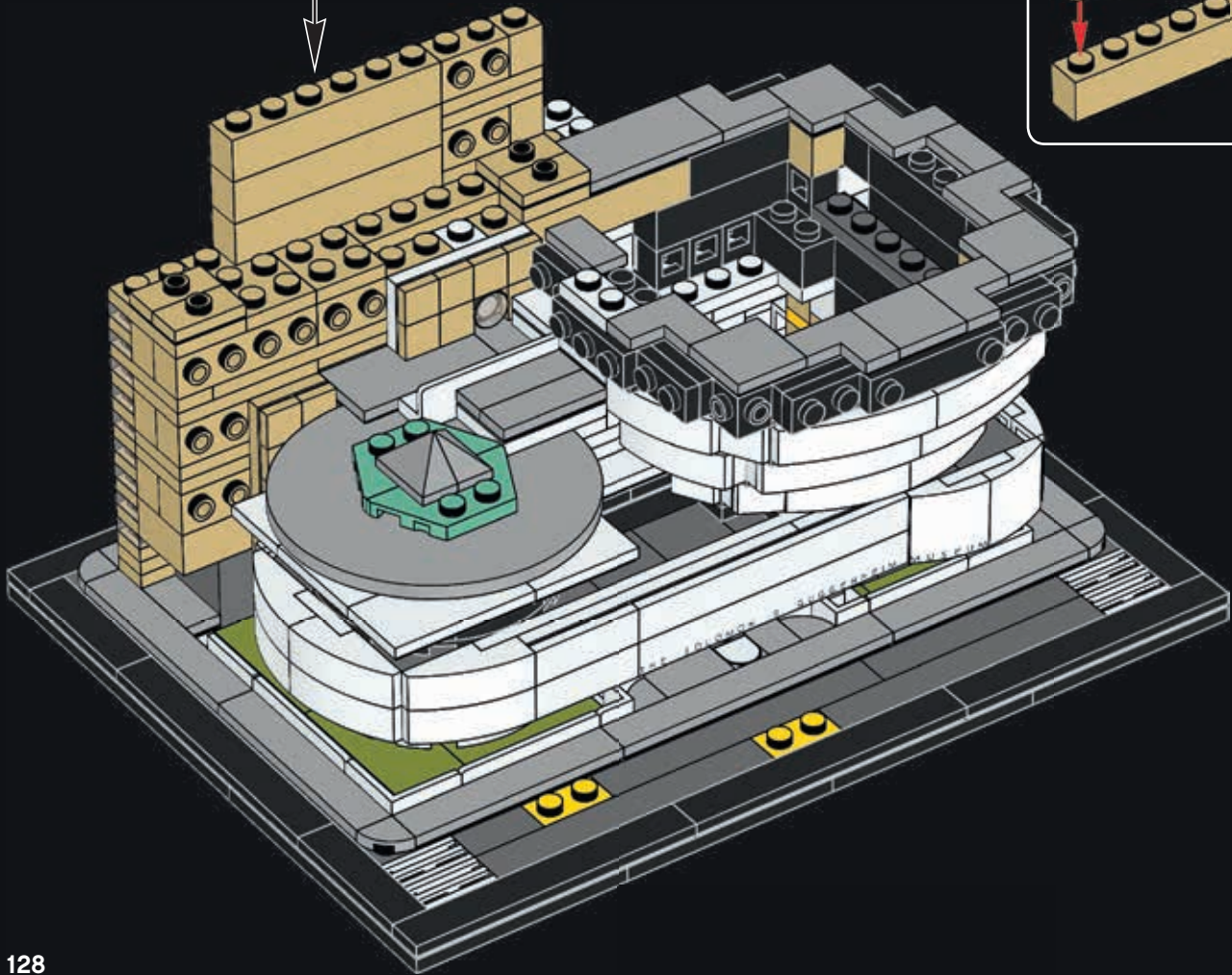



2x



1x

120

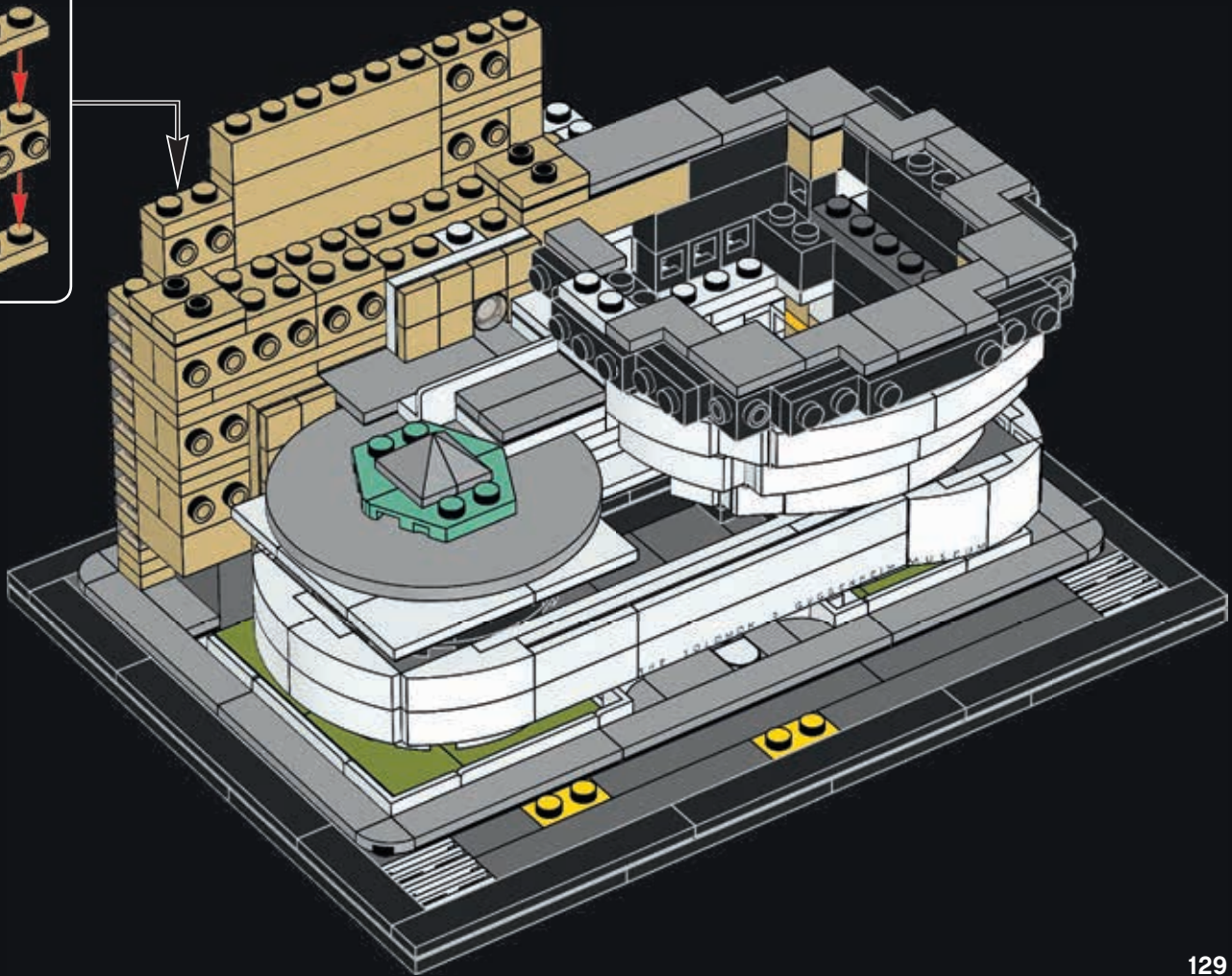
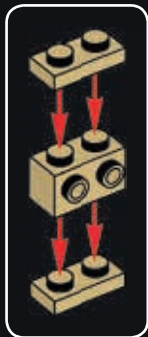



2x



3x

121

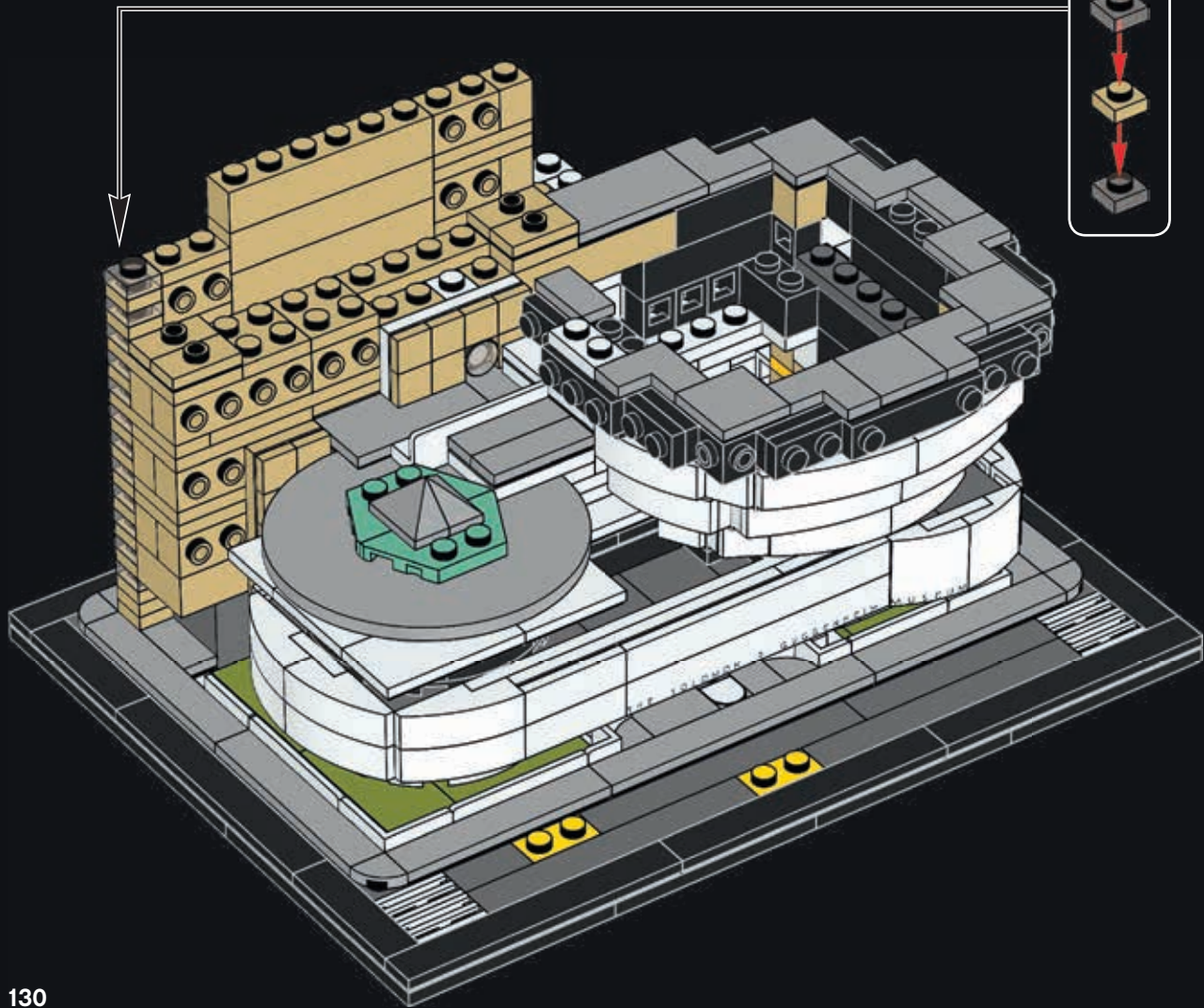



122

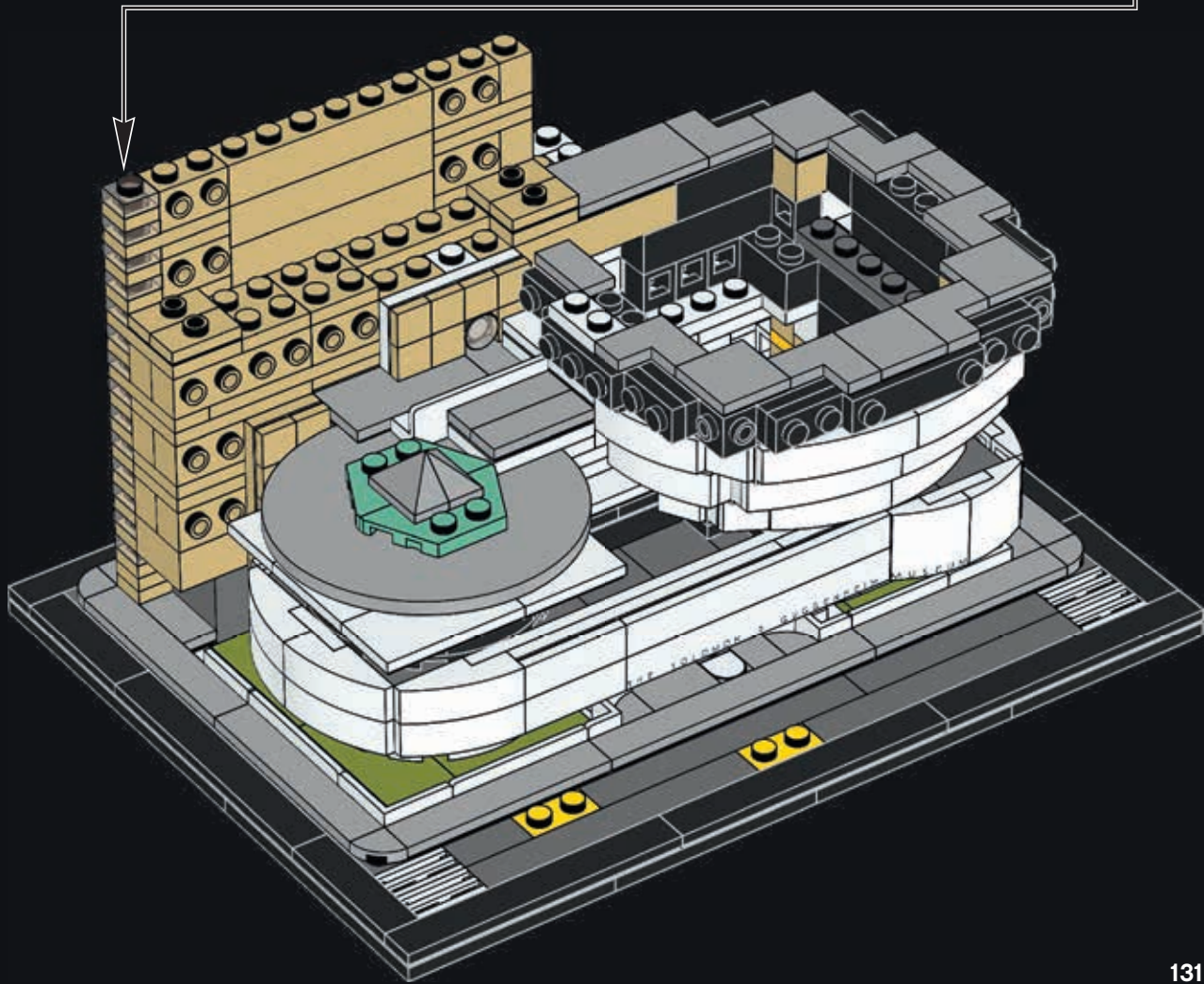

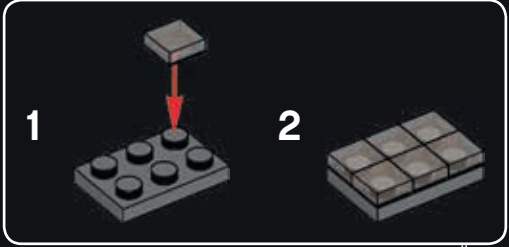
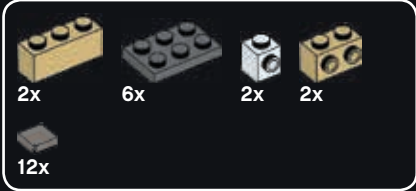

124

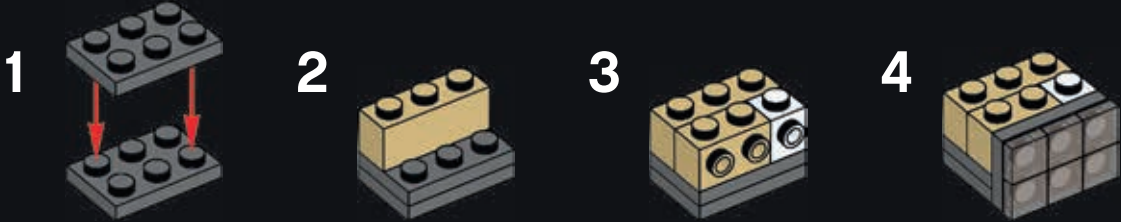

2x

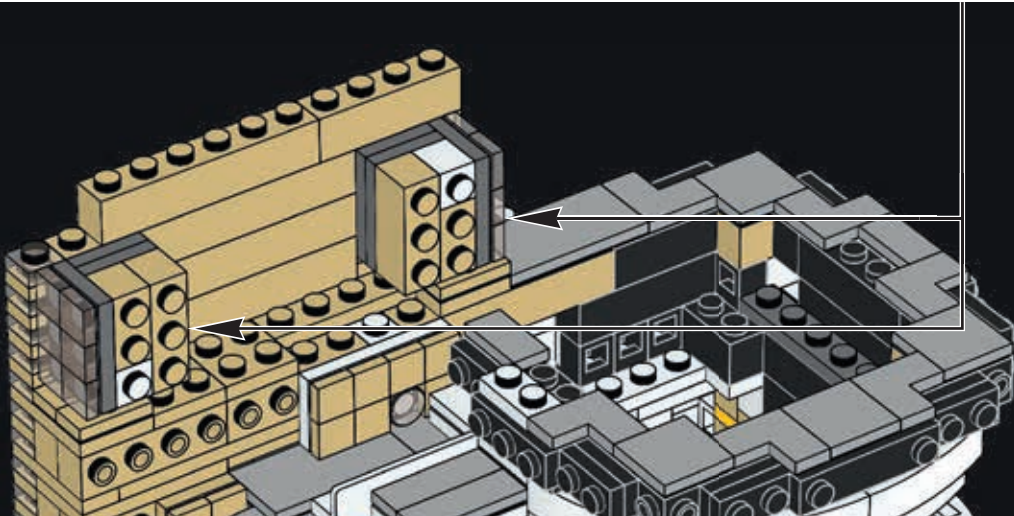



125

1

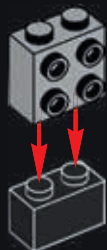

2



3



4

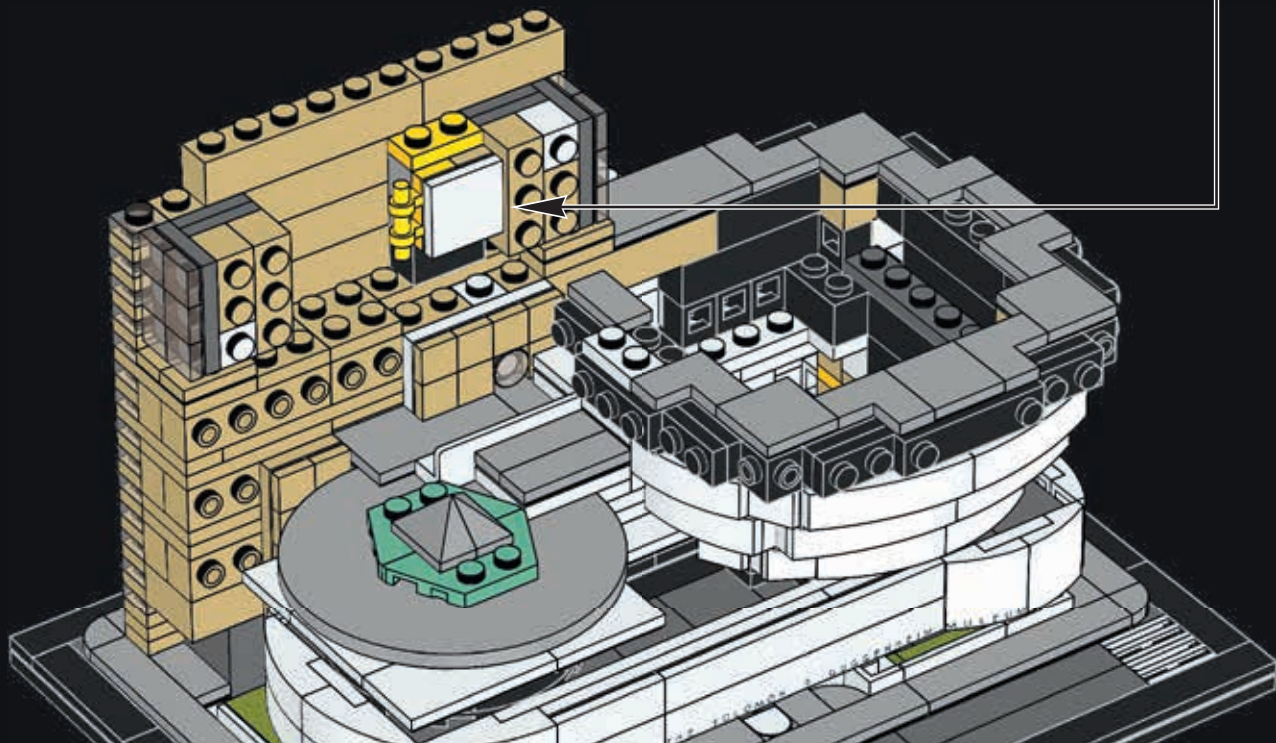

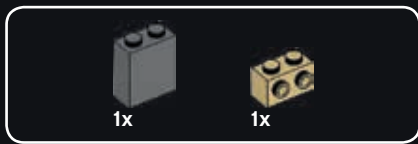

126

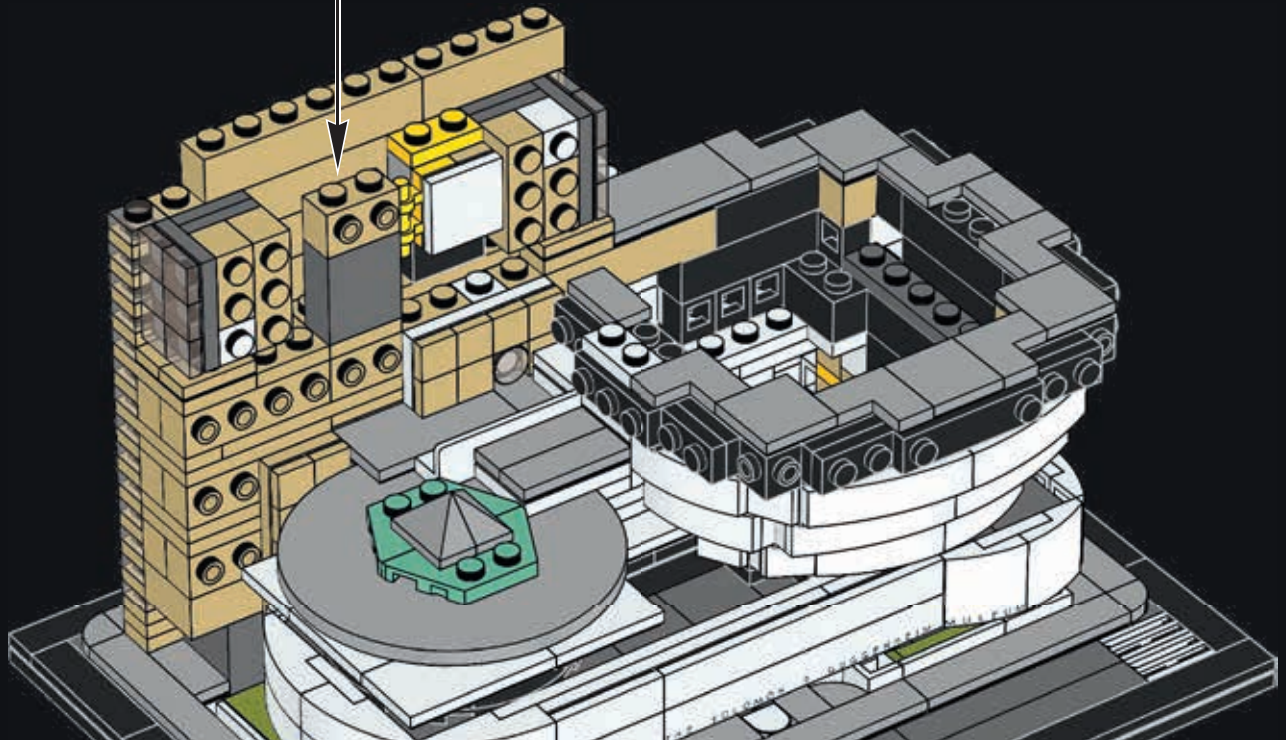
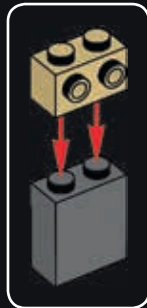

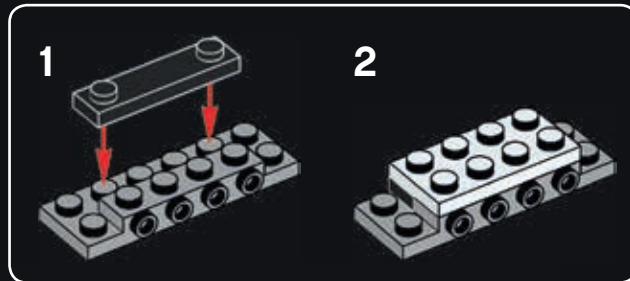
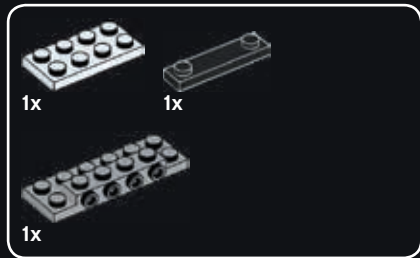

127

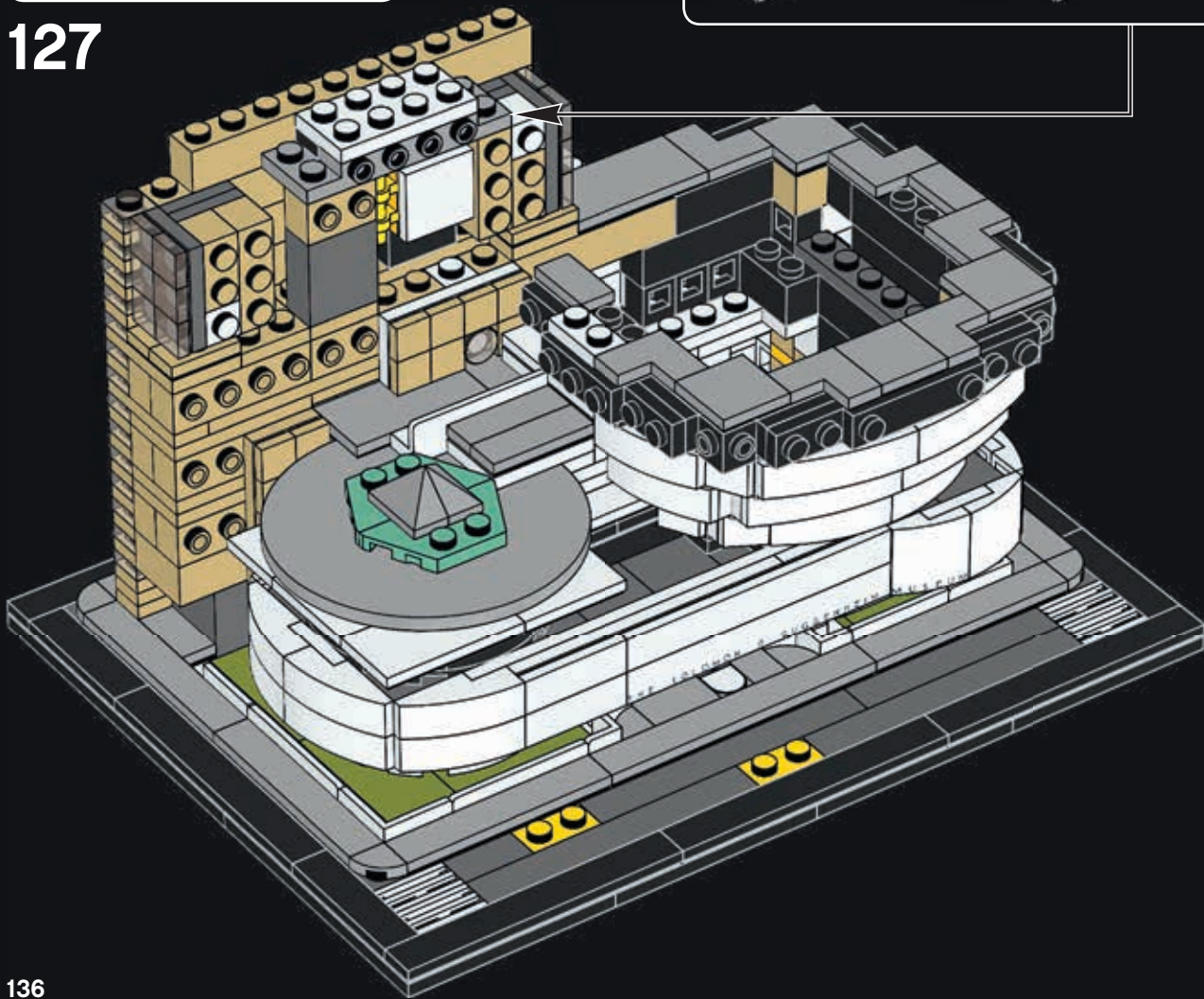



1x

128

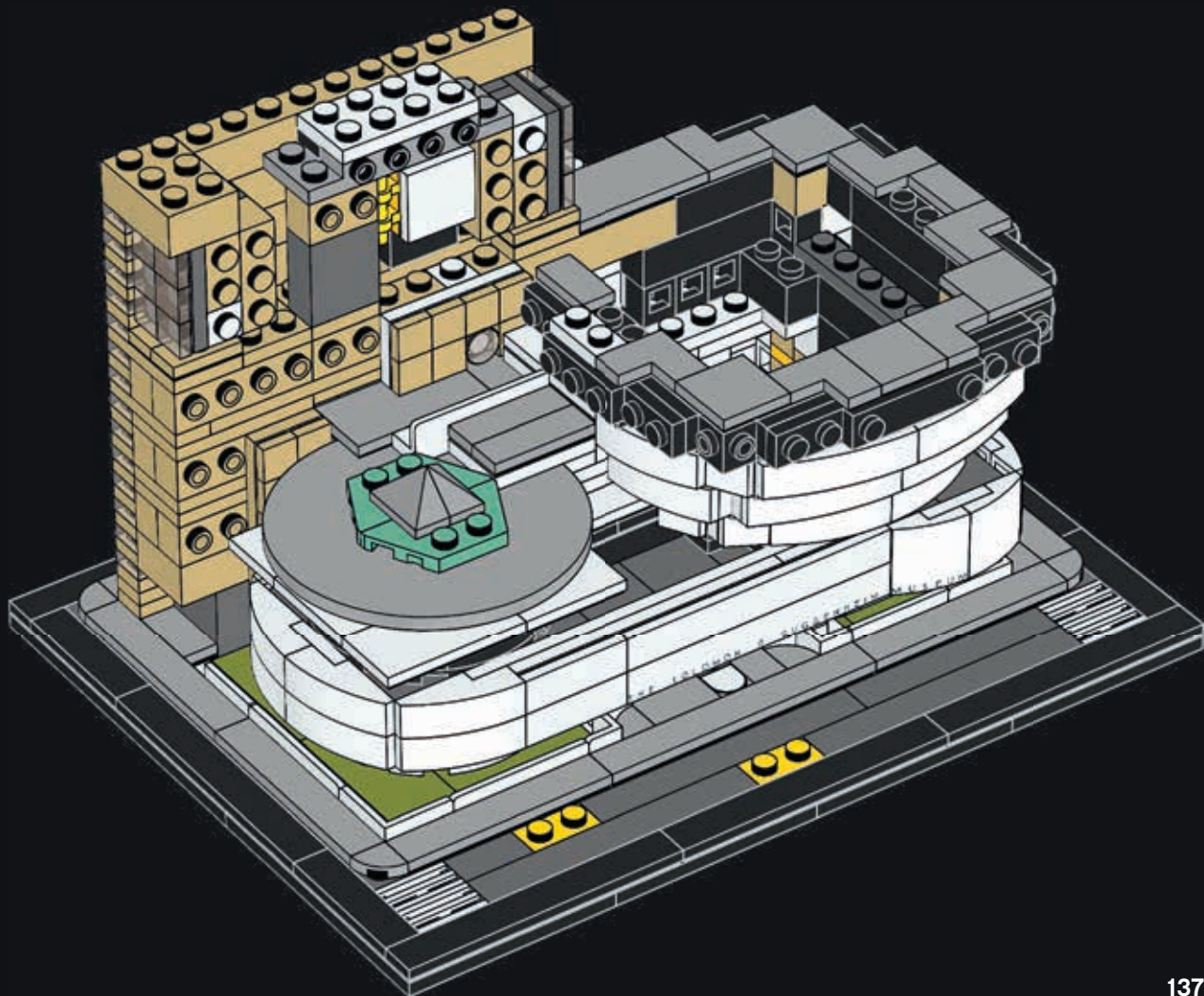

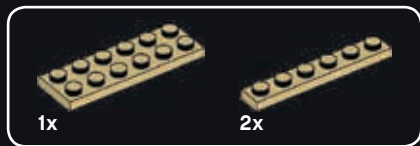

129

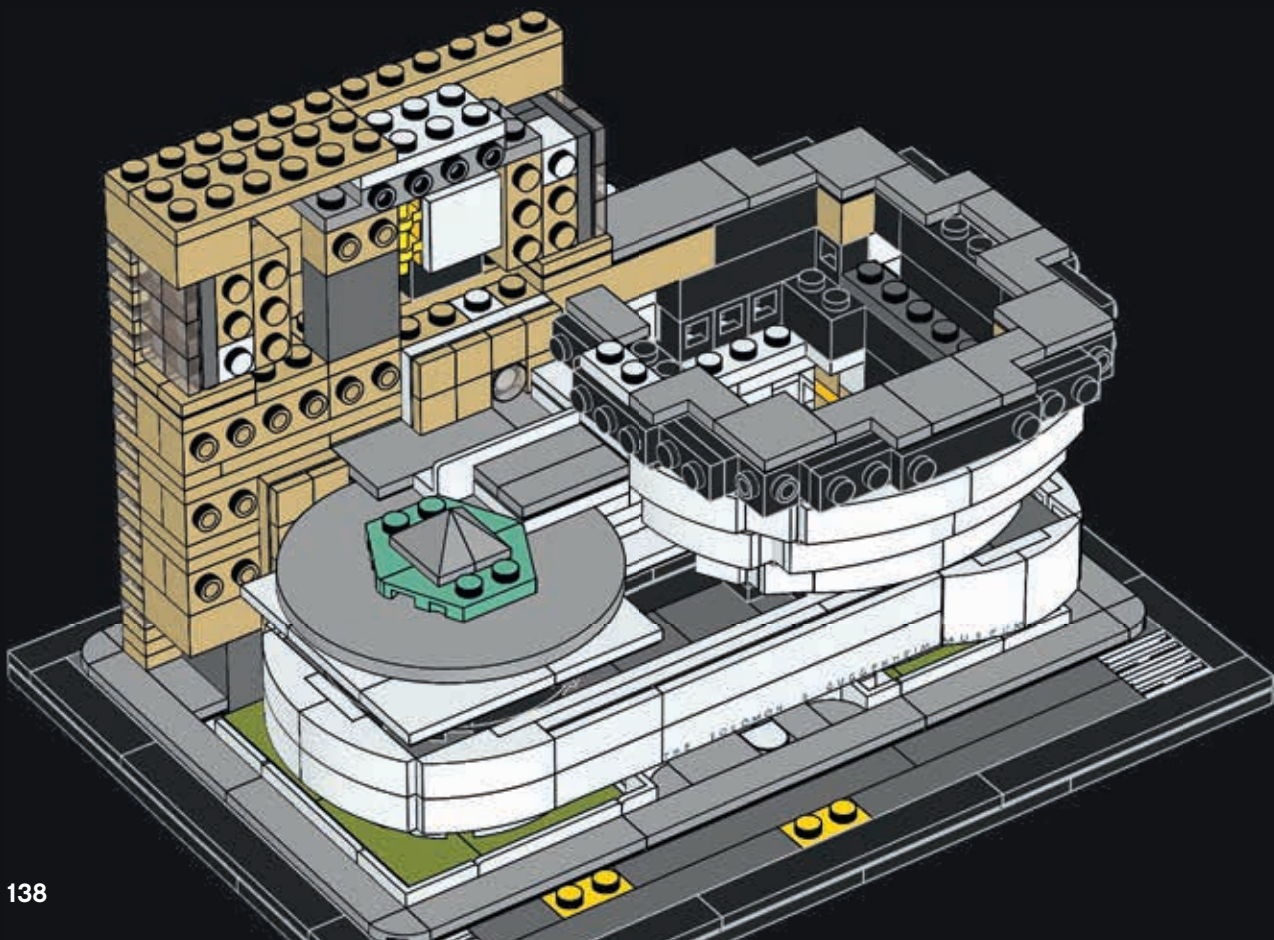



130

1

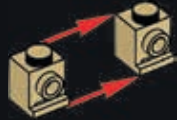

2



3

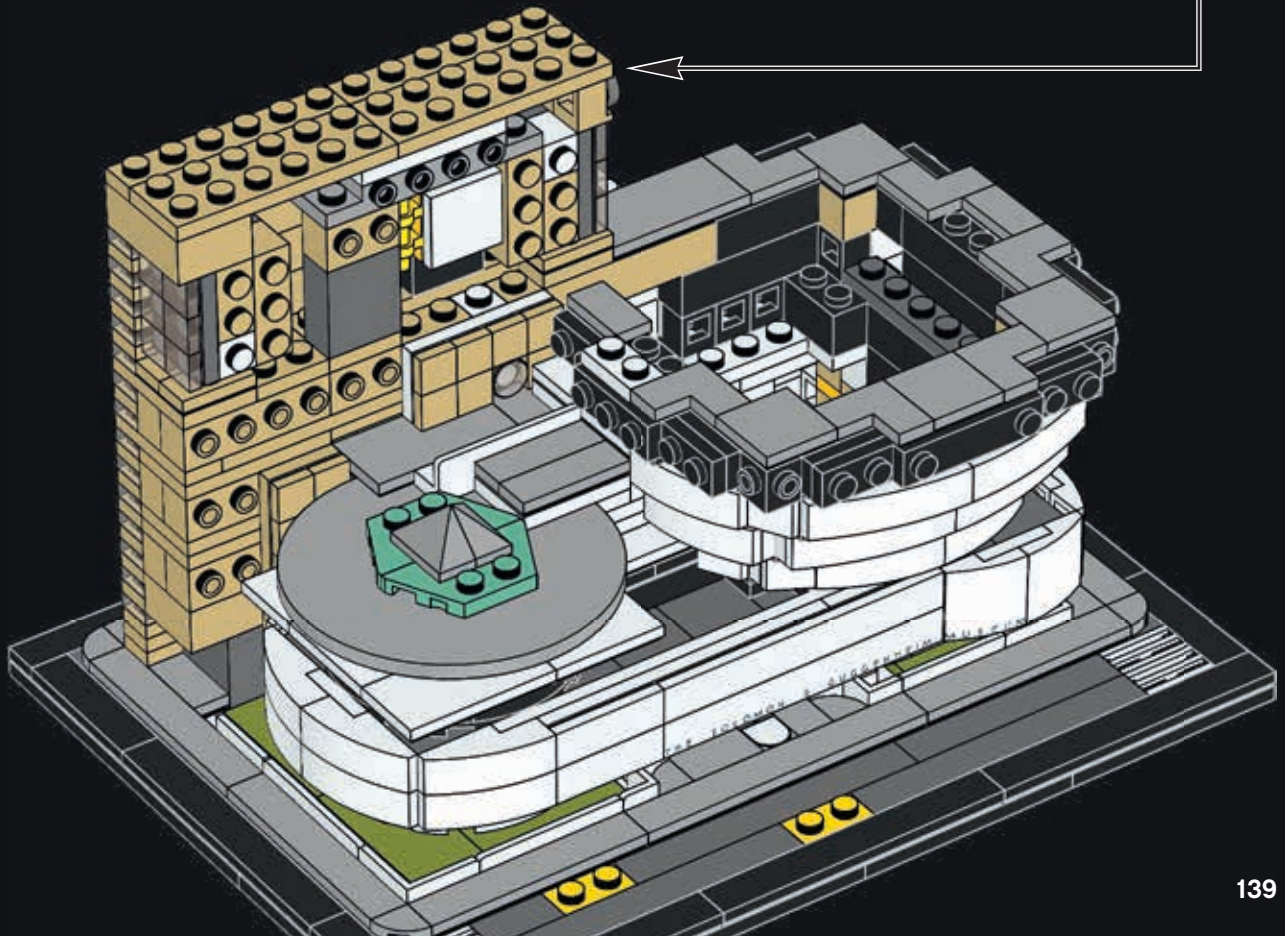

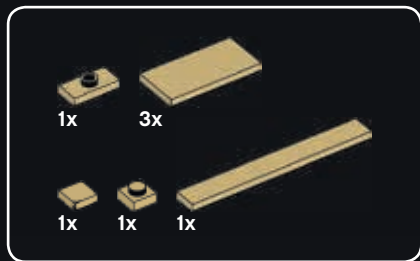

131

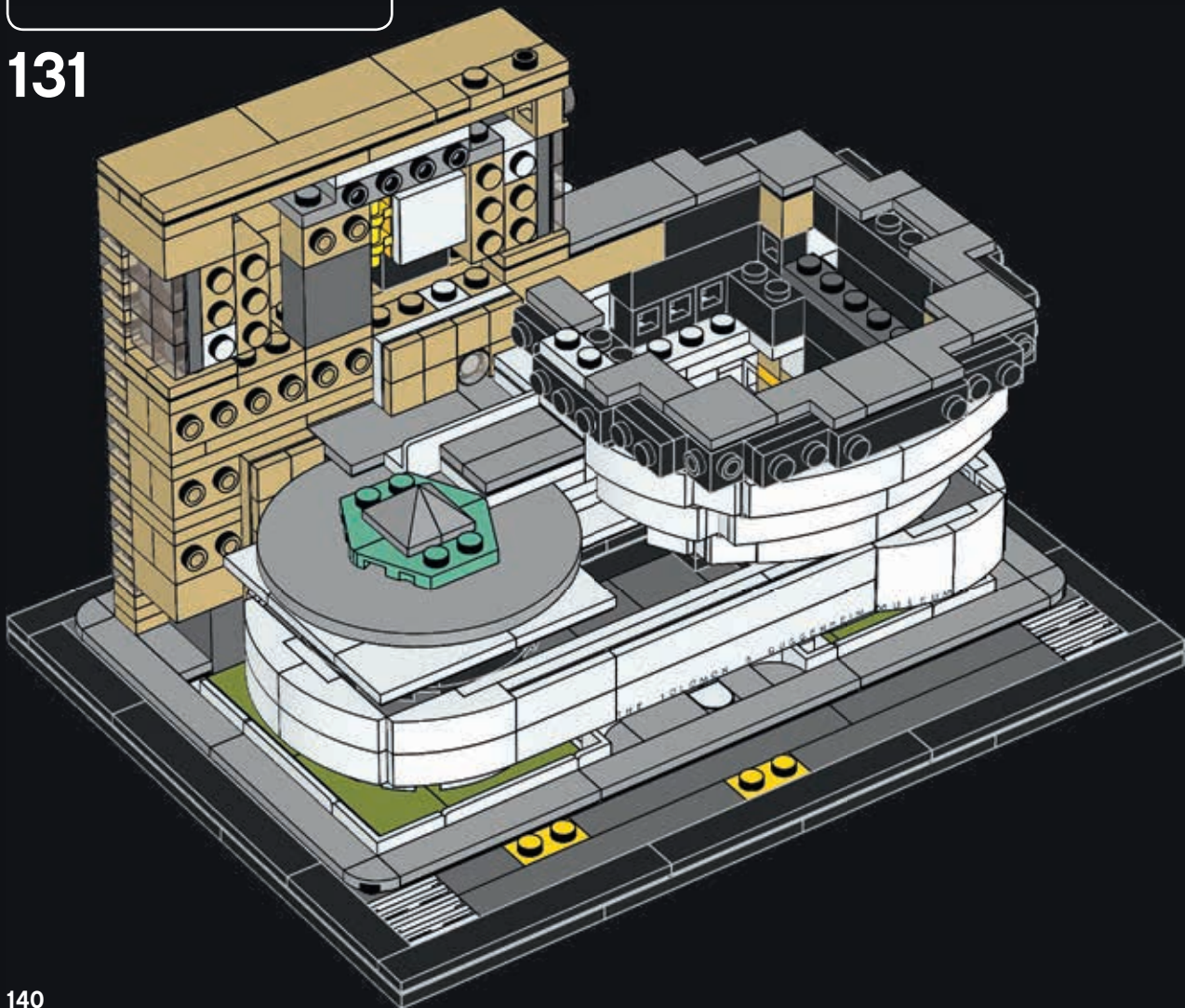

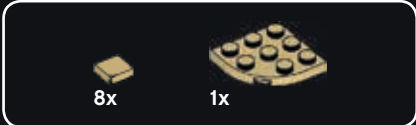

132

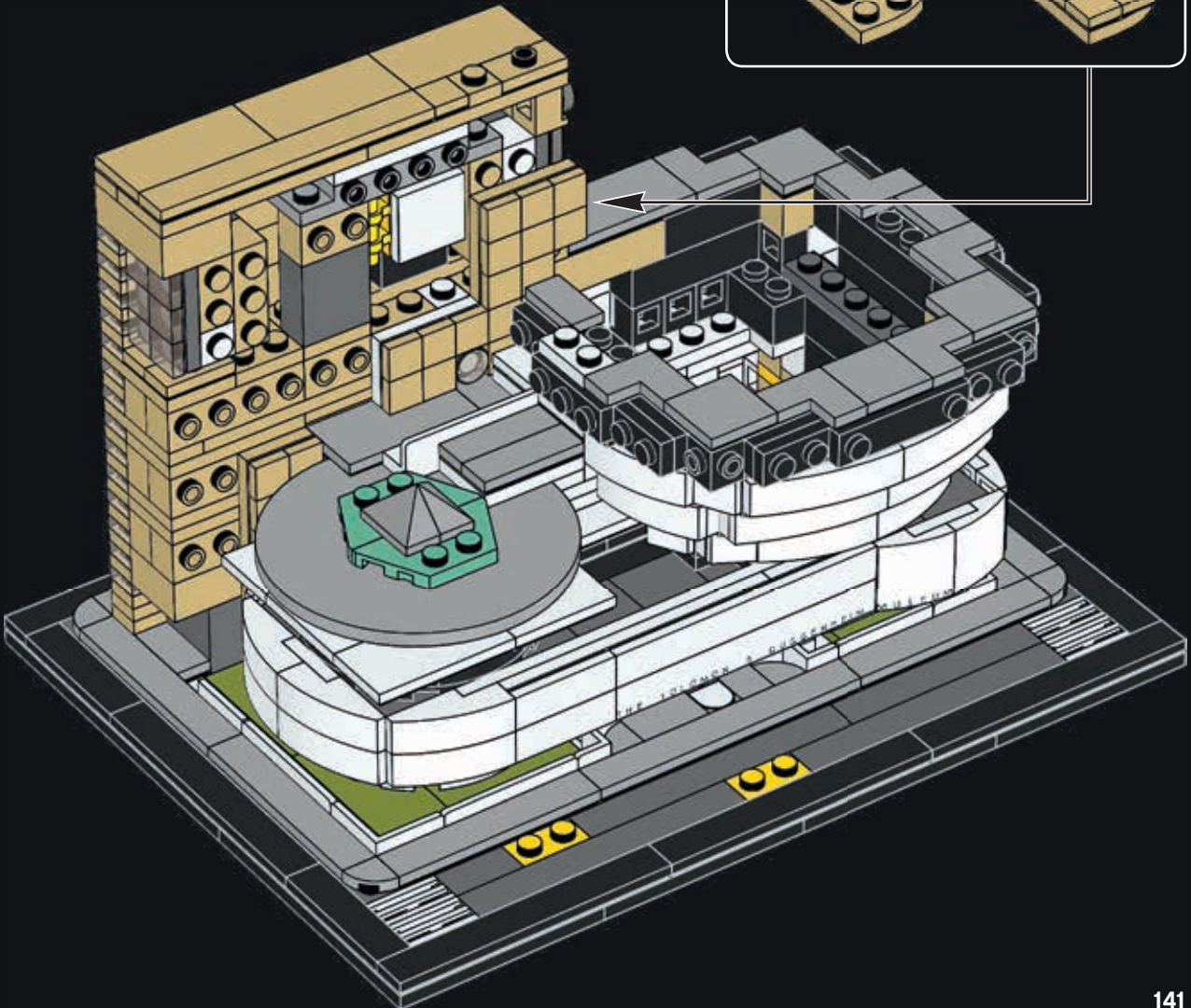
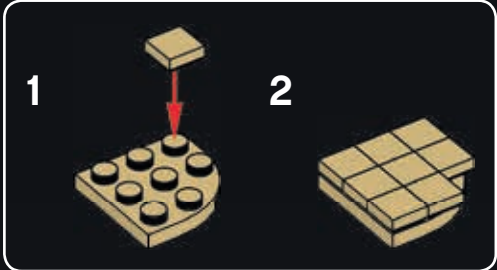



133

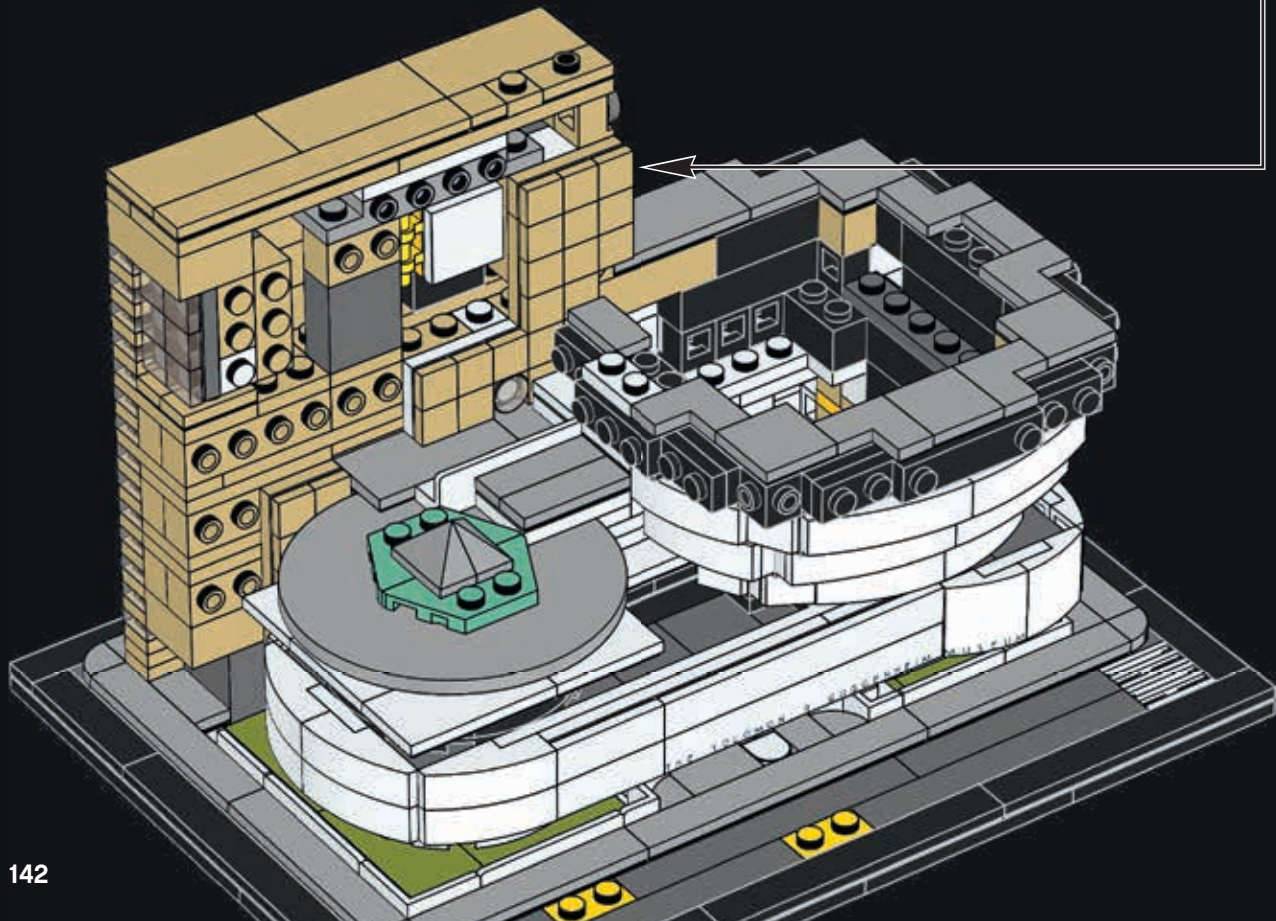
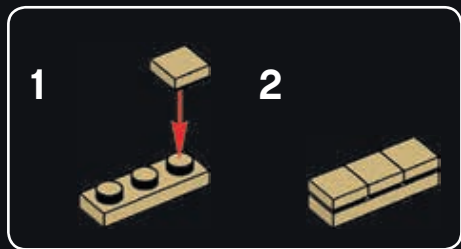



134

1

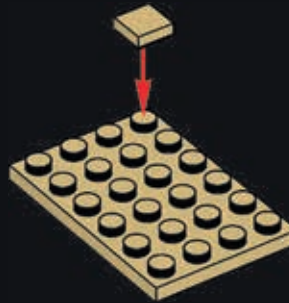

2

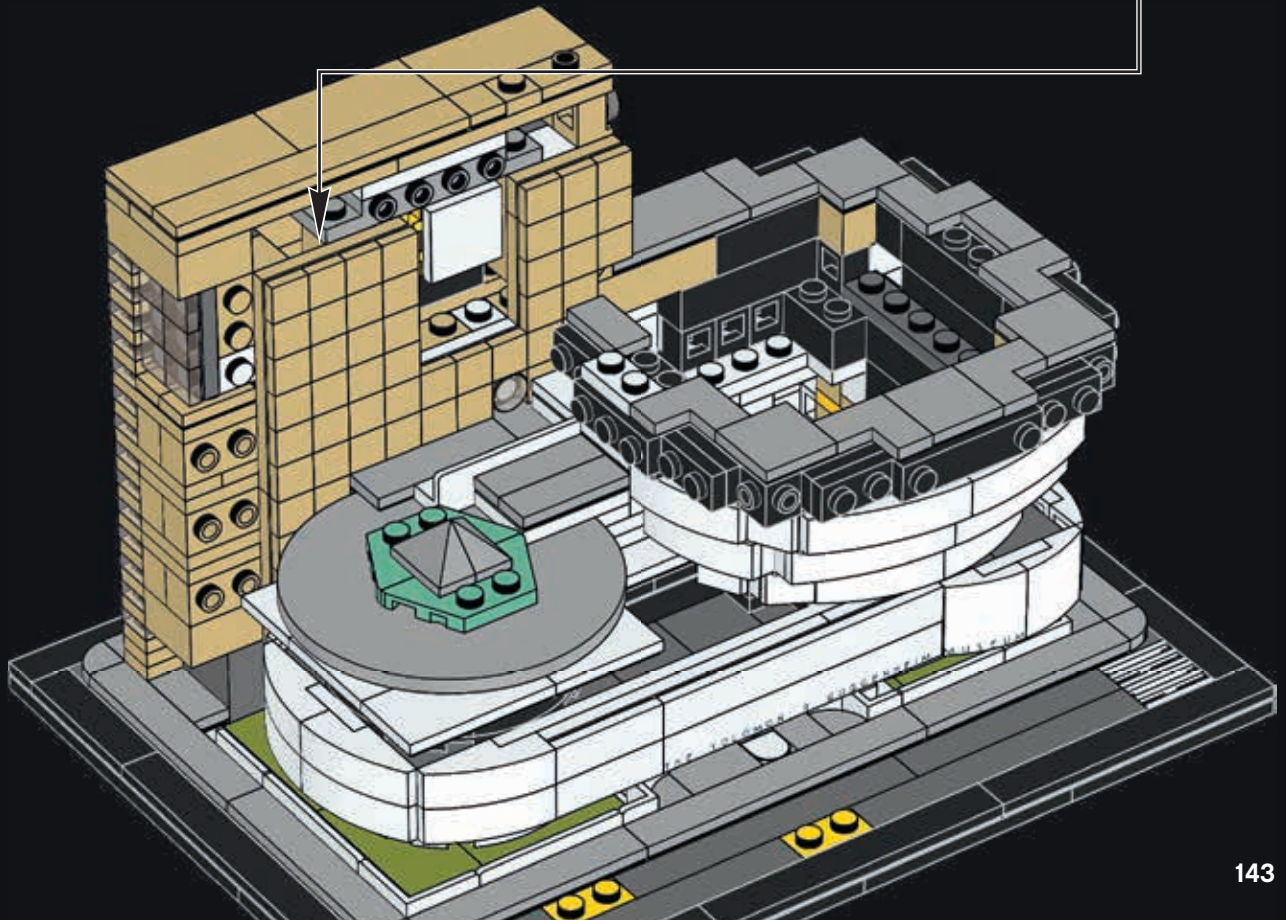



135

1

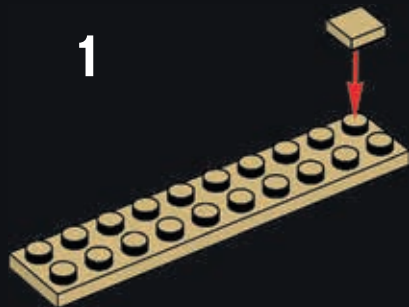

2

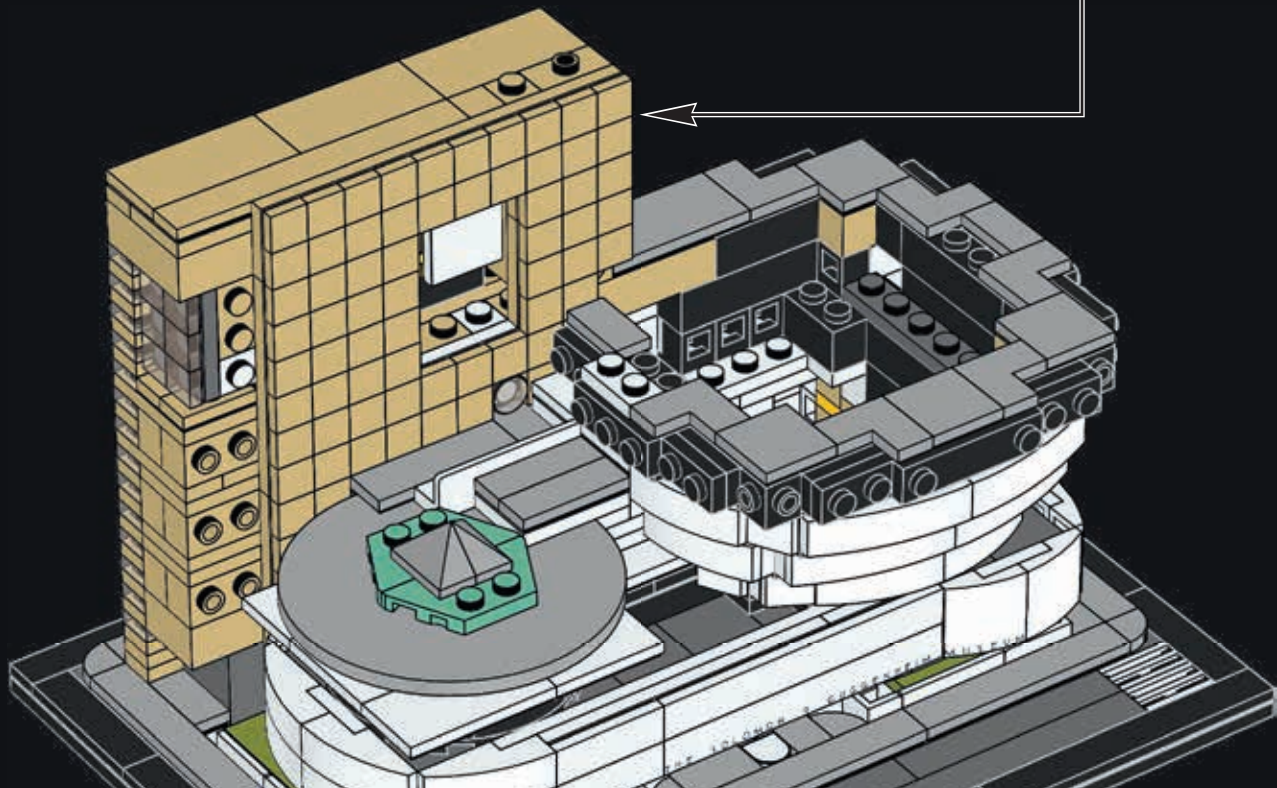
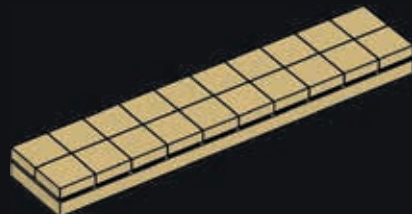

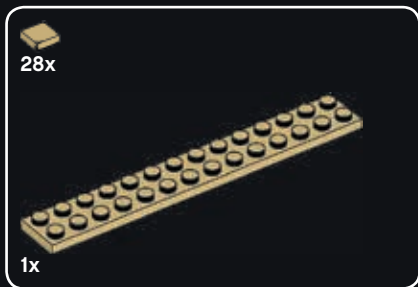

136

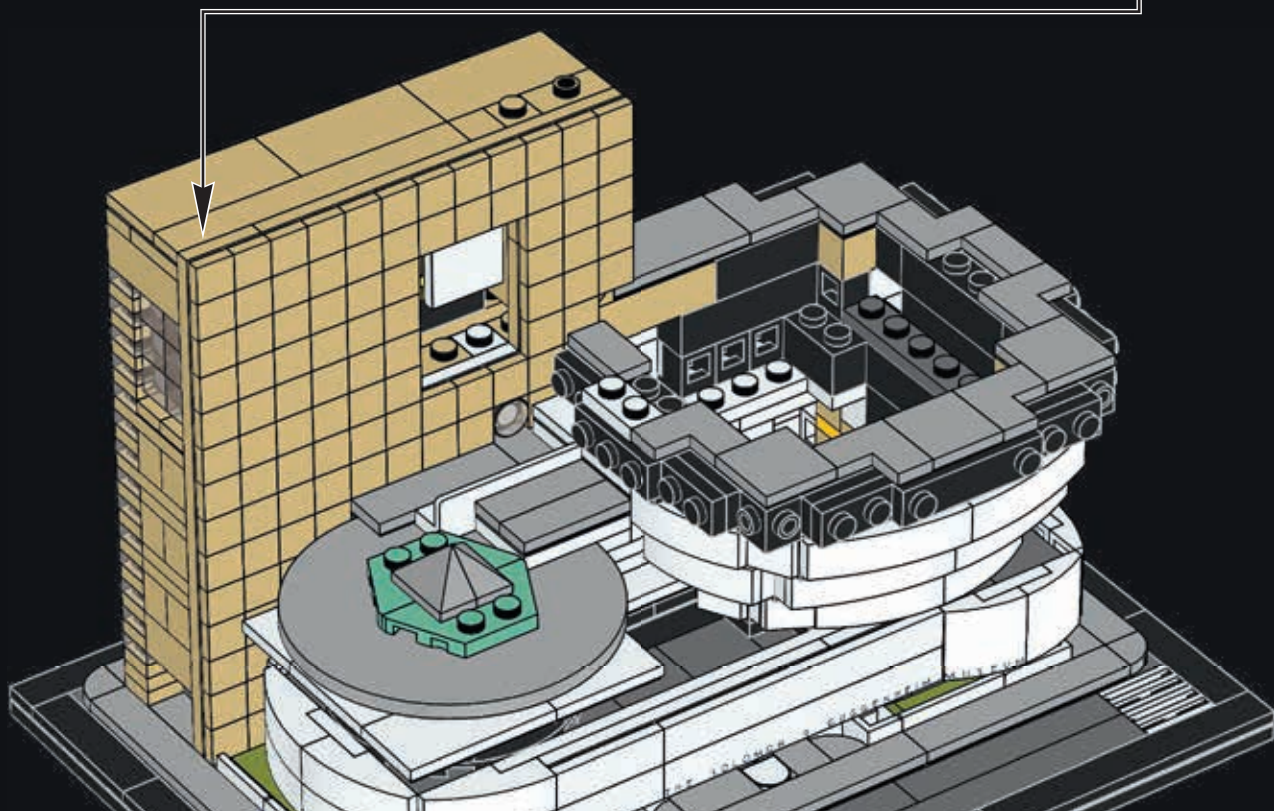
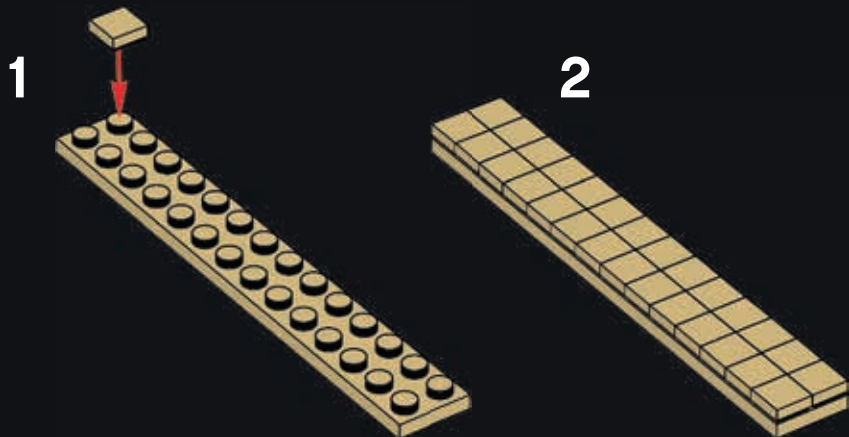



137

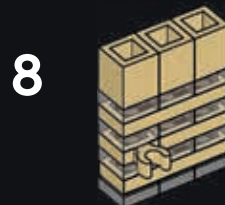

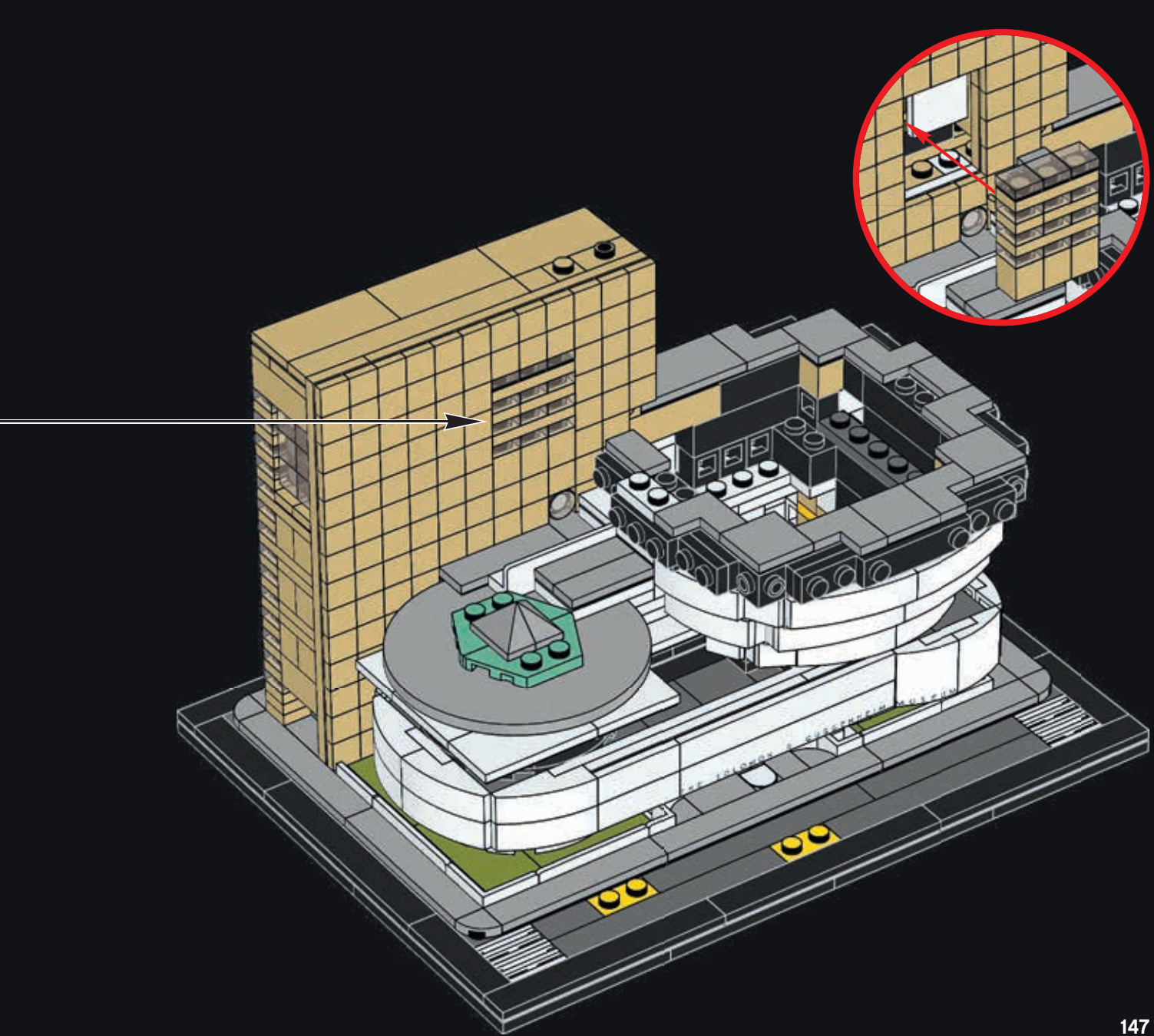

2x

138

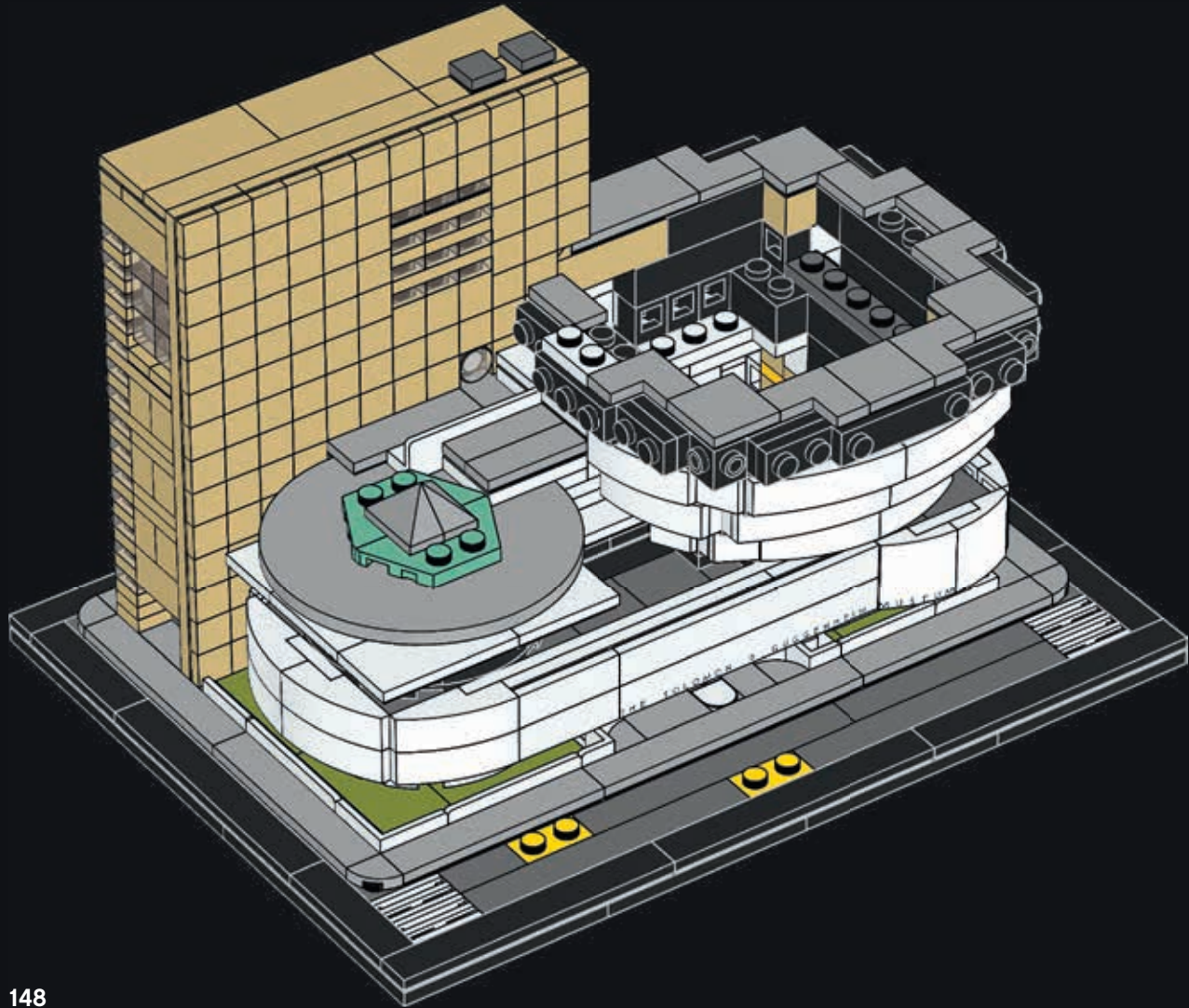

148



139

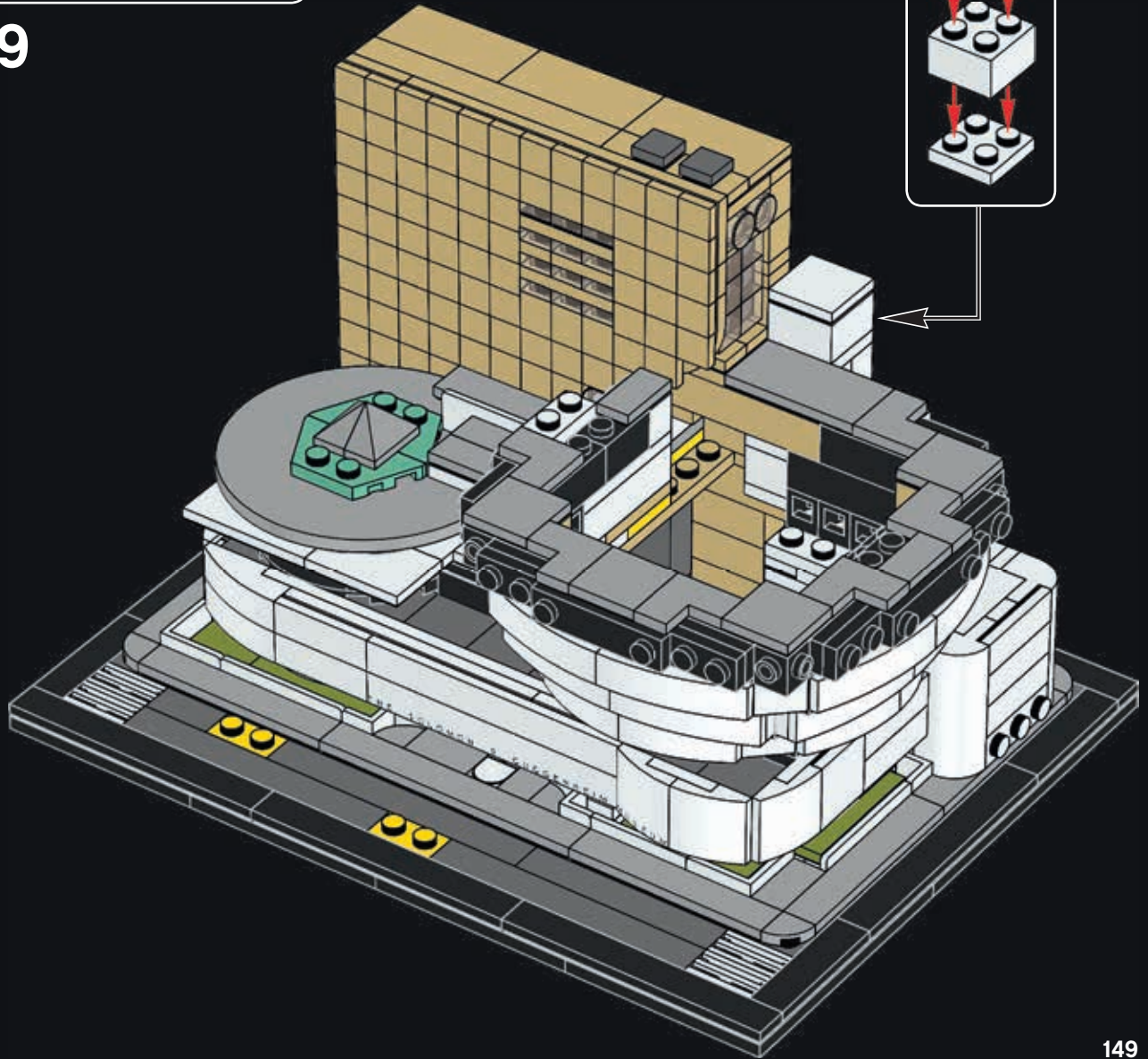



140

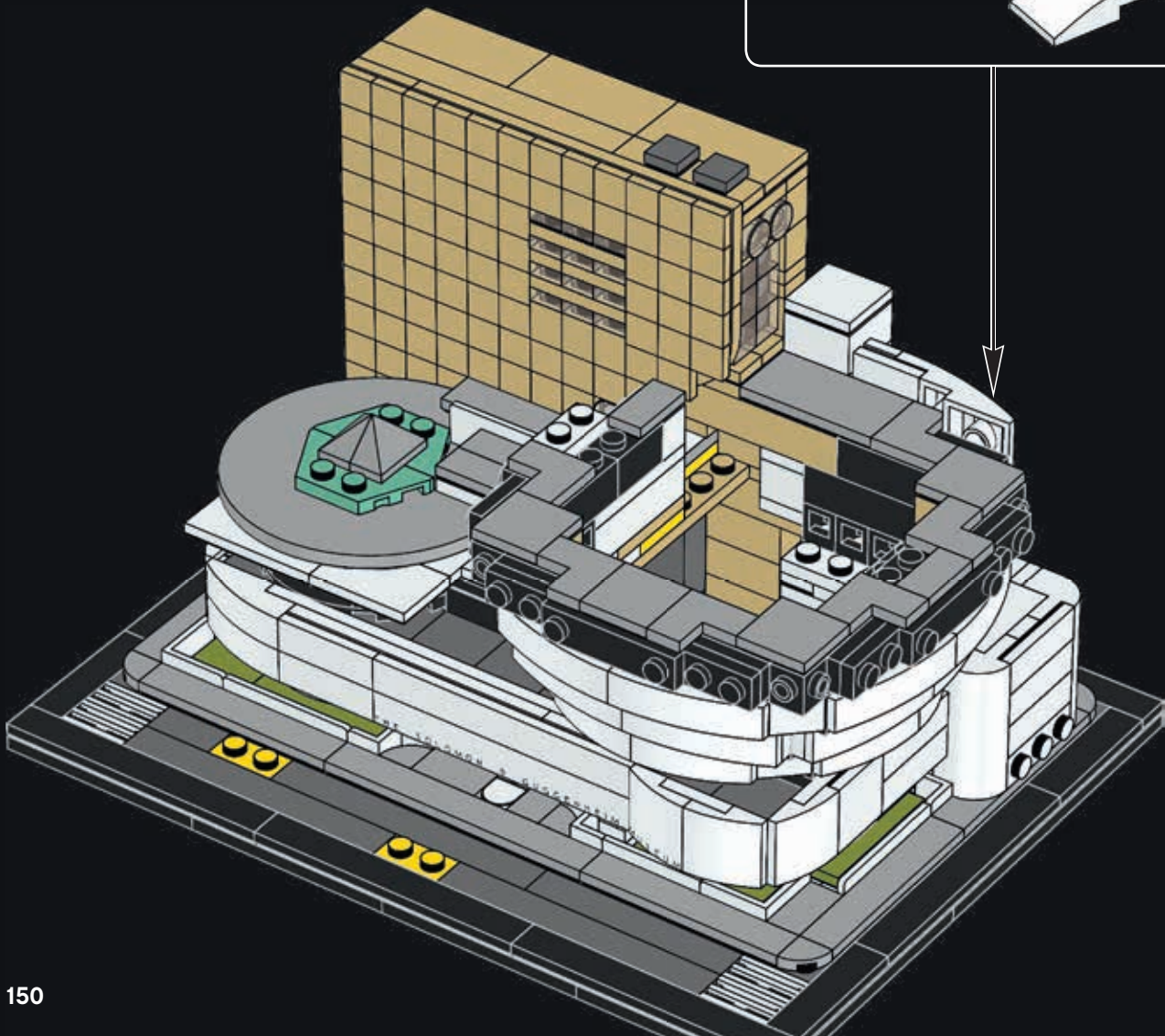
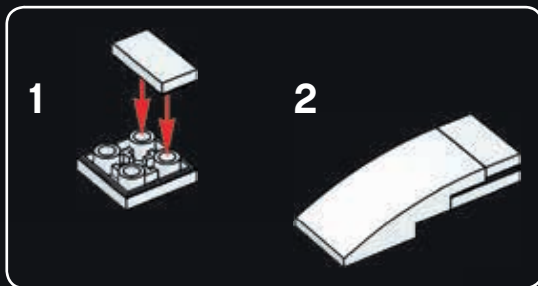



6x

141

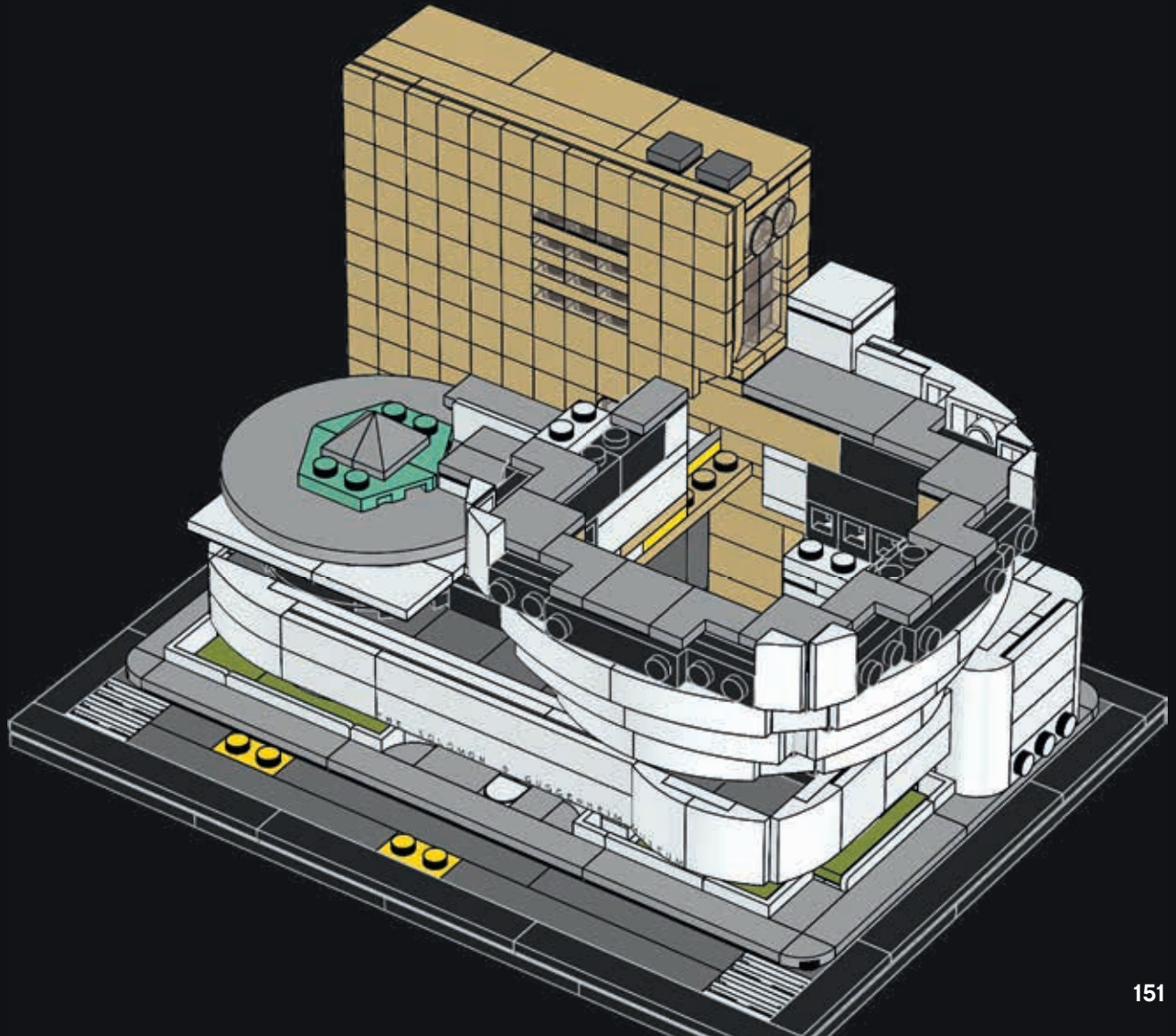

A walk up the Guggenheim ramp from the ground floor to the dome is 1,416 feet (431.5 m) long.





142

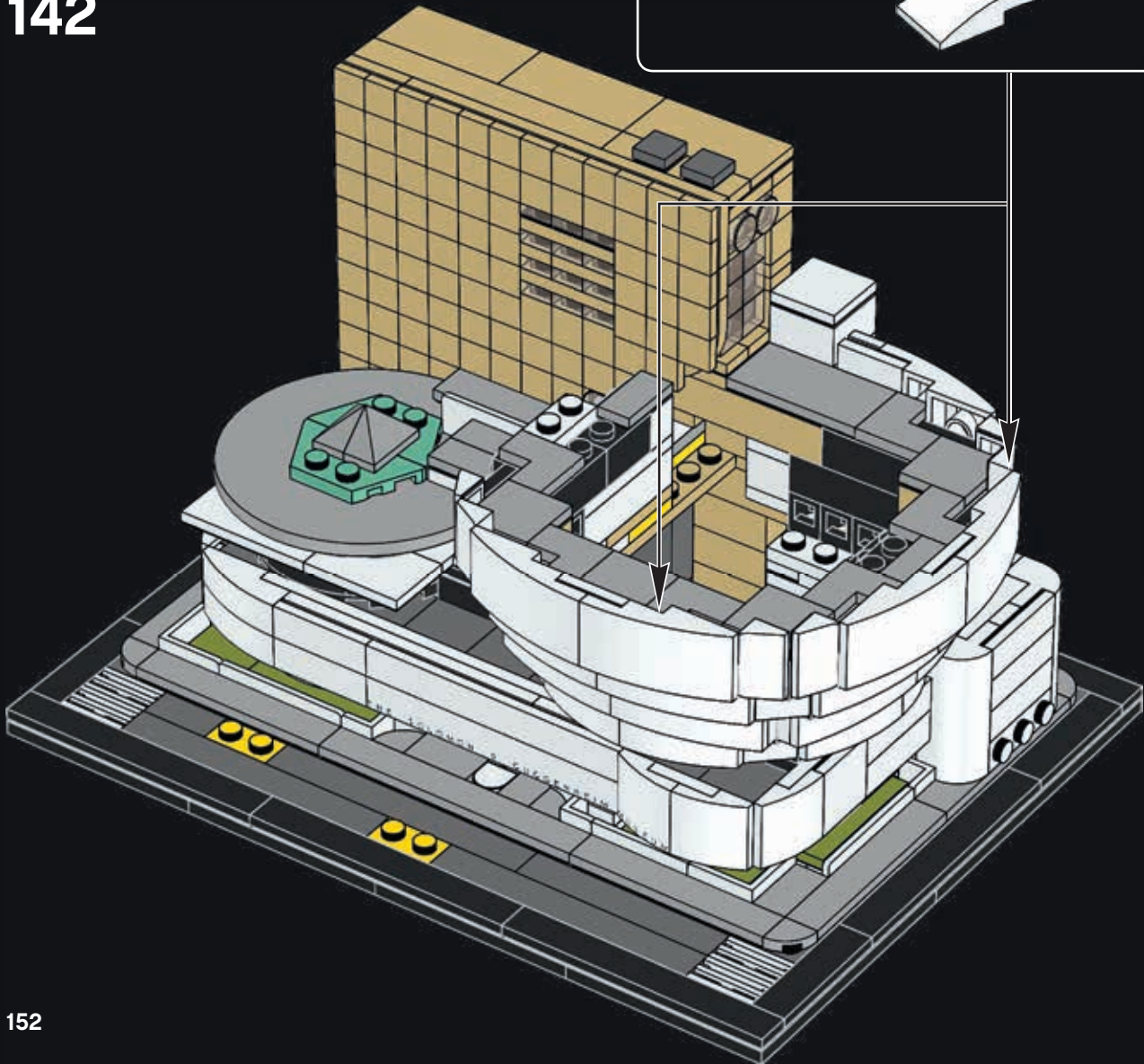



1x



1x

143

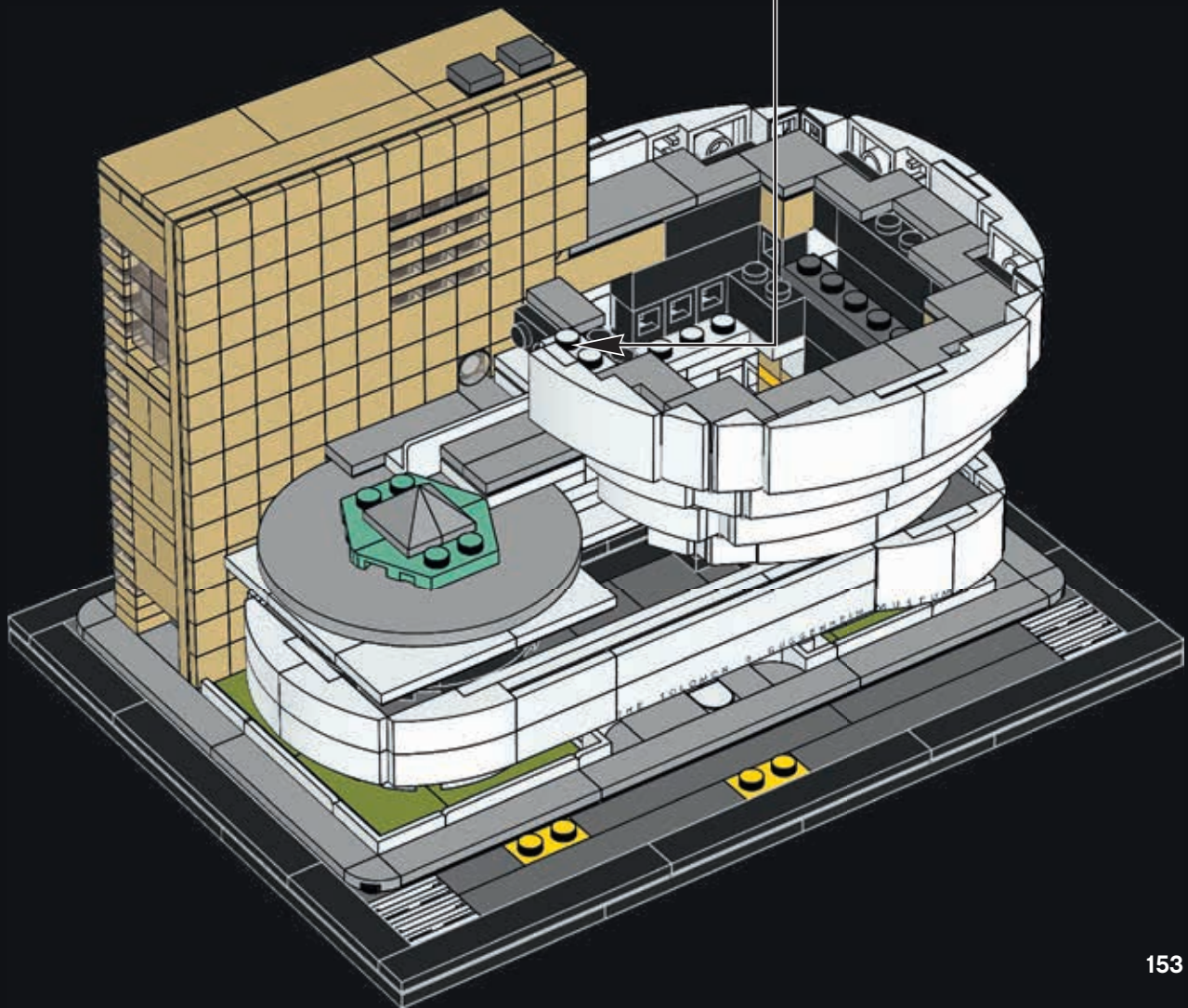



144

1

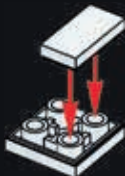

2



3

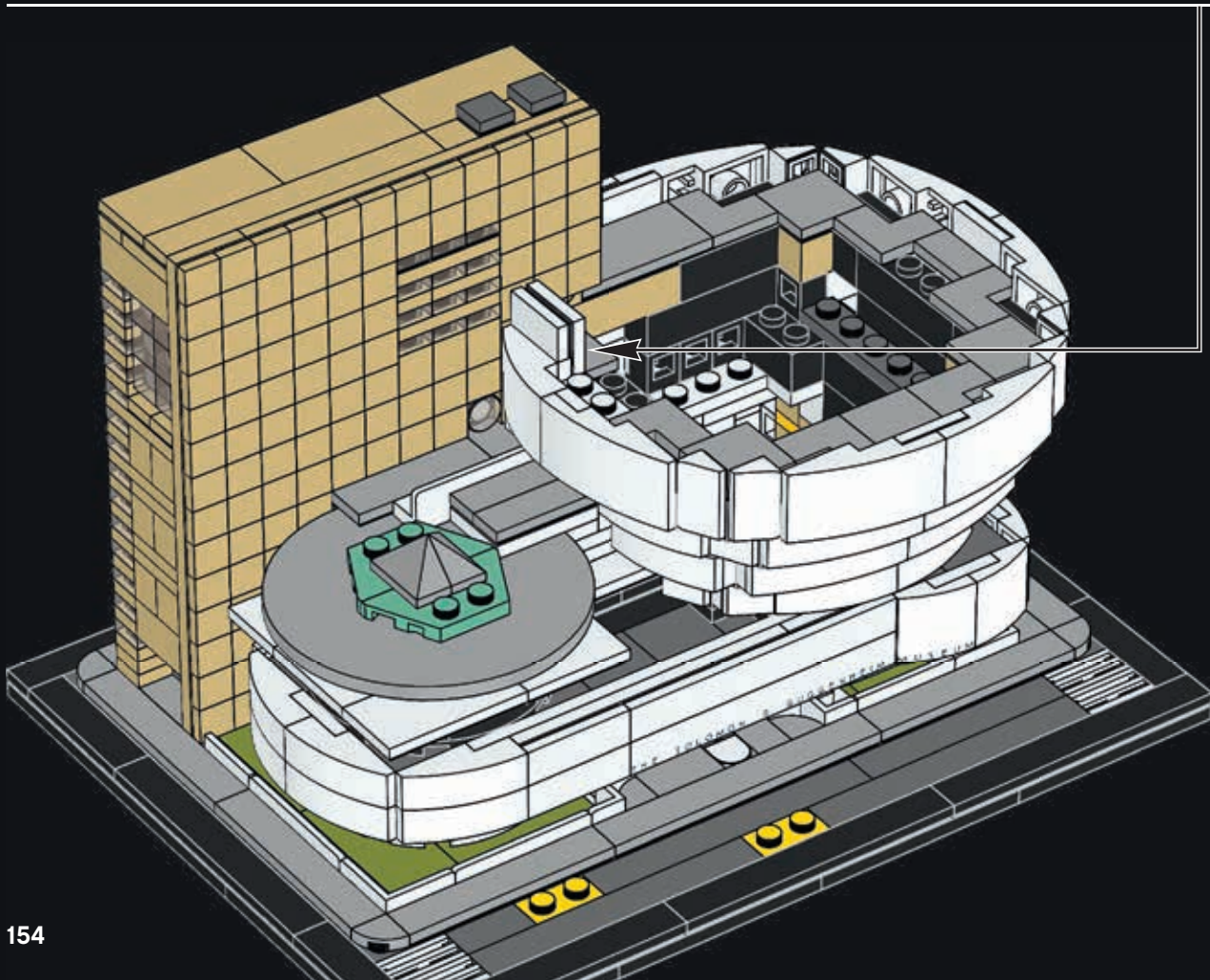

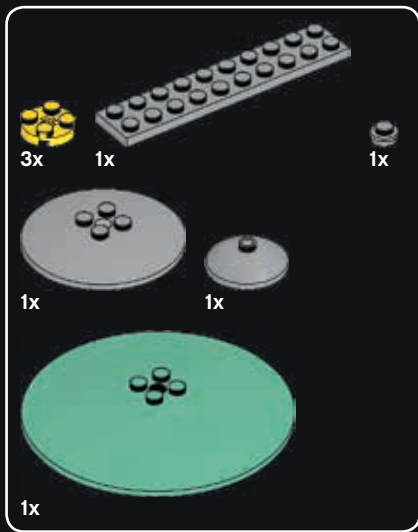

145

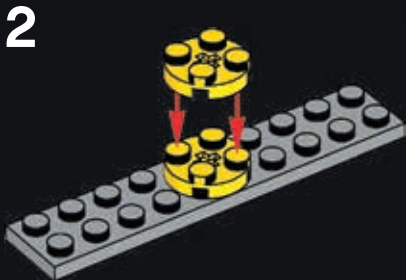

3



4



5



6



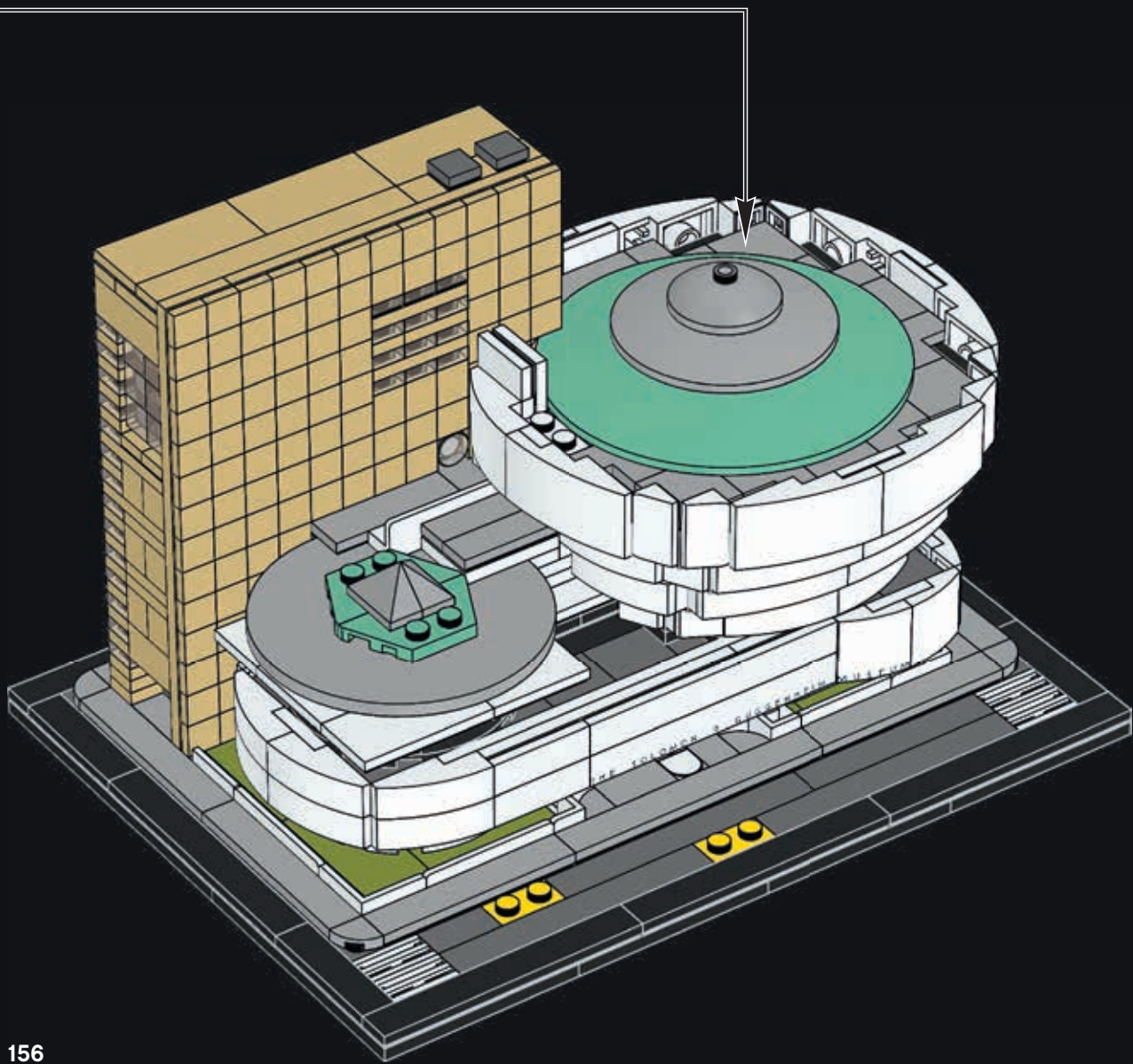

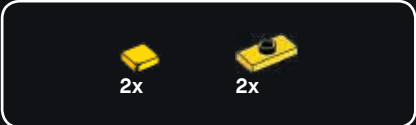

147

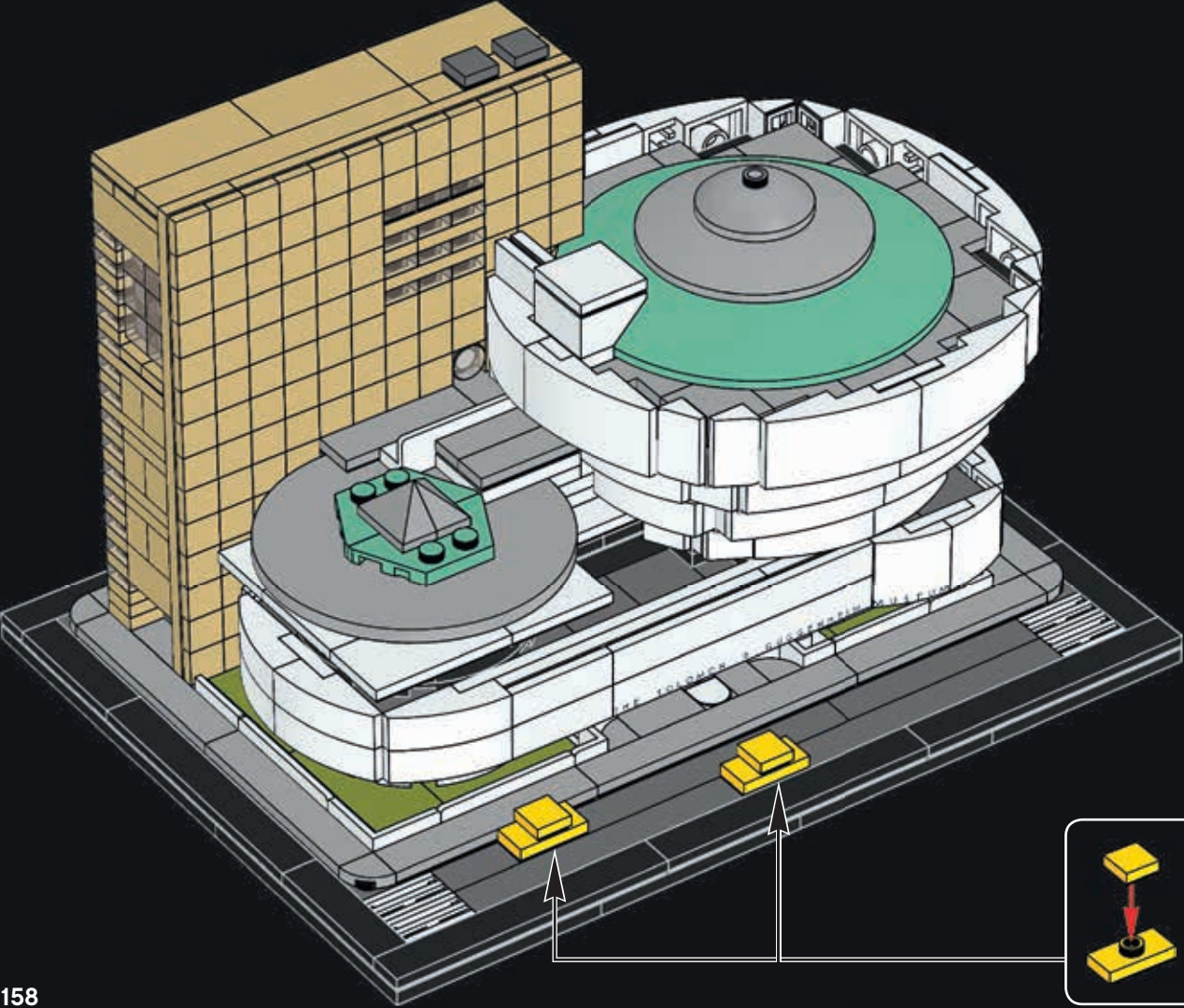



THE SOLOMON R. GUGGENHEIM MUSEUM

SPEED
LIMIT
30

ONE WAY

ONE WAY

LEGO® Architecture – do you like it?

The LEGO Group would like your opinion on the new product you have just purchased. Your feedback will help shape the future development of this product series. Please visit:

[LEGO.com/productsurvey](https://www.lego.com/productsurvey)

By completing our short feedback survey, you will be automatically entered into a drawing to win a LEGO® prize.

See website for official rules and details. Open to all countries where not prohibited.

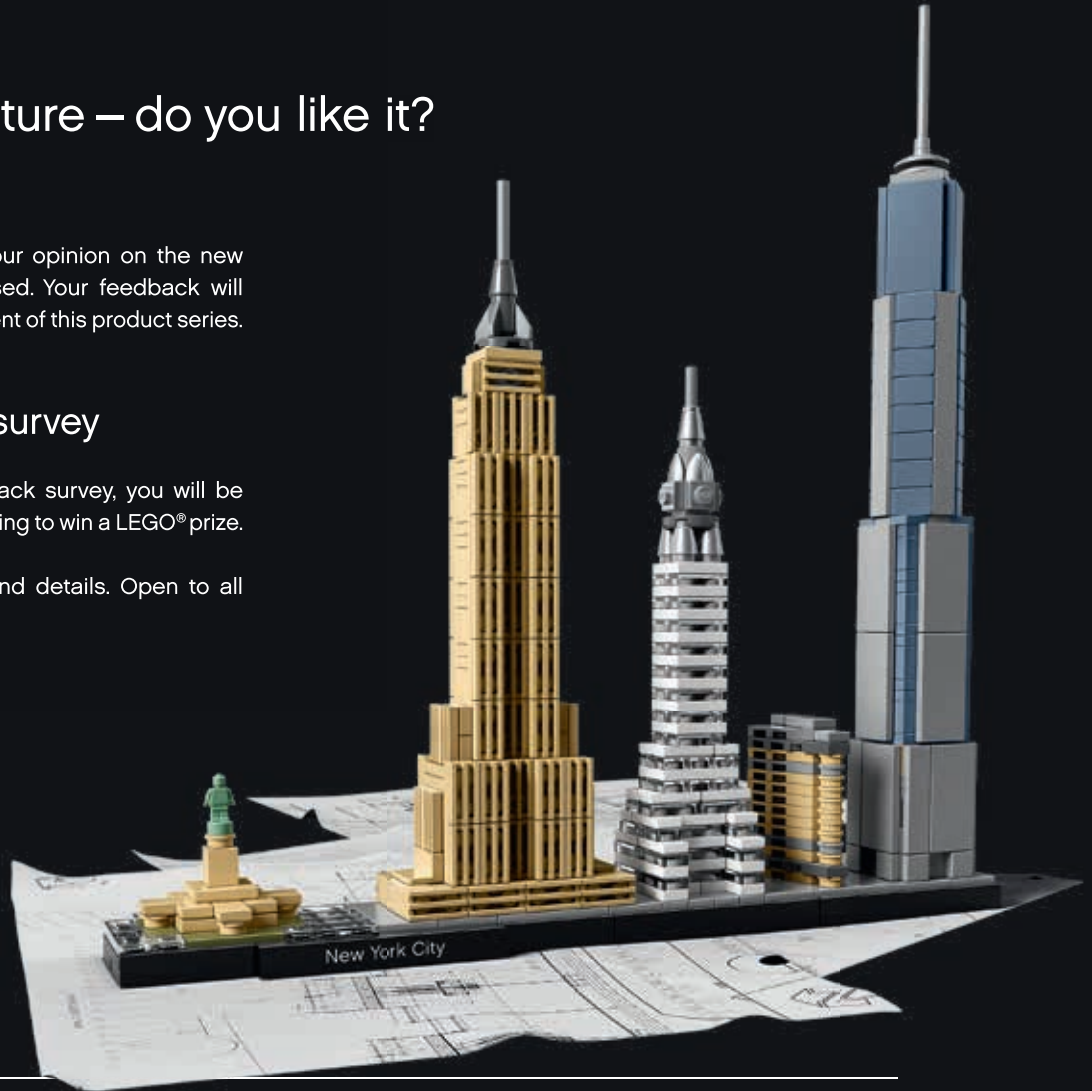

LEGO and the LEGO logo are trademarks of the/sont des marques de commerce du/son marcas registradas de LEGO Group. ©2017 The LEGO Group.

LEGO® Architecture – then and now

There has always been a natural connection between the LEGO® brick and the world of architecture. Fans who build with LEGO elements instinctively develop an interest in the form and function of the structures they create. At the same time, many architects have discovered that LEGO bricks are the perfect way of physically expressing their creative ideas.

This connection was confirmed in the early 1960s with the launch of the LEGO 'Scale Model' line. It matched the spirit of the age where modern architects were redefining how houses look and people were taking an active interest in the design of their new homes. These sets were designed to be different from the normal, brightly colored LEGO boxes; they also included a book on architecture as a source of inspiration.

Decades later, architect and LEGO fan Adam Reed Tucker revived the idea of expressing architecture using LEGO bricks and in partnership with the LEGO Group,

launched the LEGO Architecture line that we know today. His first models, and the original sets in the current LEGO Architecture series, were interpretations of famous skyscrapers from his hometown of Chicago. Since then LEGO Architecture has developed and evolved, first with well-known buildings from other cities in the United States, and now with iconic structures from Europe, the Middle East and Asia.

The introduction of our LEGO Architecture Studio set echoes the ambitions of the earlier LEGO 'Scale Model' line and widens the potential of the LEGO Architecture series. Now you can enjoy building and learning about specific landmark buildings, or create exciting architectural models from your own fantasy. An inspiring 270-page book, featuring a number of renowned architects from around the world, guides you through the principles of architecture and encourages you in your own creative building.



21050
Studio

References

Photo credits:

www.shutterstock.com

©The Solomon R. Guggenheim Foundation, New York p. 2, 7, 9, 10

For further information please visit:

www.guggenheim.org

Customer Service
Kundenservice
Service Consommateurs
Servicio Al Consumidor
LEGO.com/service or dial



00800 5346 5555: 

1-800-422-5346: 

Celebrate the world of architecture

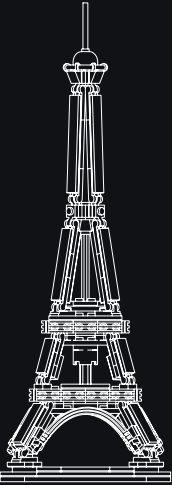

21019
The Eiffel Tower

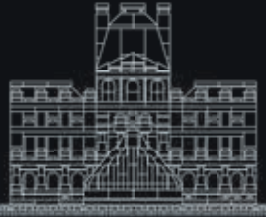

21024
Louvre

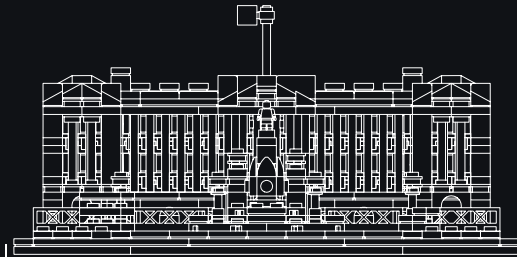

21029
Buckingham Palace

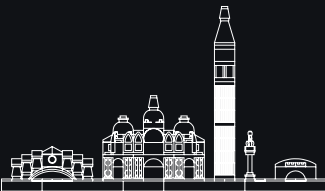

21026
Venice



21027
Berlin



21028
New York City

and collect all the models



21030
United States Capitol Building

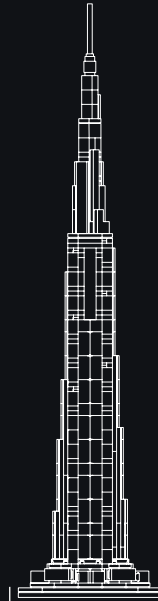

21031
Burj Khalifa

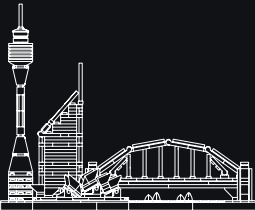

21032
Sydney



21033
Chicago

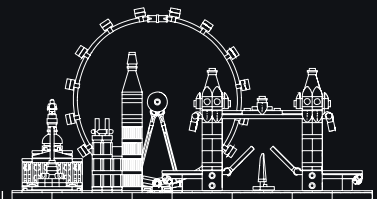

21034
London

3x
6131655

3x
4504369

7x
4558952

7x
307001

16x
302401

5x
623101

6x
4547489

4x
241201

3x
306901

16x
302301

2x
6146215

8x
300401

1x
6034044

3x
4121932

8x
302201

4x
6013866

4x
306801

3x
6047220

1x
366001

1x
300301

2x
6181753

7x
6046979

1x
6139694

7x
362301

11x
4249112

7x
4558168

4x
362201

1x
6182352

1x
6132212

3x
6156667

4x
302101

2x
300201

3x
243101

3x
301001

11x
371001

10x
6045936

4x
6061047

4x
302001

2x
4560178

6x
6031947

2x
608101

1x
300101

2x
366601

1x
617901

1x
4215470

3x
6109817

2x
379501

1x
416201

1x
6182355

2x
303401

3x
244501

1x
4119227

2x
4118793

19x
4159553

13x
4113915

103x
4125253

1x
6029889

5x
6092587

7x
6024495

4x
4113917

1x
6061575

9x
4121921

6x
4162465

8x
4118790

1x
4159739

4x
4201062

2x
4113916

1x
4543858

4x
4114309

3x
6122047

5x
4114319

3x
4124067

5x
4112982

3x
4113993

1x
4544139

6x
4159774

1x
4114001

1x
4113988

2x
4249019



1x
6036487



3x
307024



4x
403224



4x
6092583



12x
302324



1x
4140587



4x
302224



1x
4243817



23x
407026



12x
302326



4x
6092585



6x
300426



7x
6138173



2x
300326



12x
362326



4x
6187587



4x
6187572



7x
4599499



4x
243126



12x
4162443



3x
301026



1x
4159550



1x
379526



1x
379526



8x
416226



4x
303626



4x
303326



4x
4565323



1x
4654448



3x
6079000



15x
6038458



23x
6030982



2x
6187591



1x
6187588



1x
4211525



6x
6176433



2x
6075075



8x
4211414



1x
6123809



4x
4211413



8x
6065824



1x
6070564



8x
4211429



4x
4558169



3x
4560183



8x
4211549



1x
4160560



1x
4211796



1x
4211796



1x
6102575



1x
4211481



1x
4211481



1x
4625582



1x
4211462



2x
4210848



7x
4210978



4x
4211052



6x
4211055



8x
4211043



4x
4211056



1x
4210651



3x
4211008



4x
4210998



2x
6133611



1x
6047015



6x
6016488



1x
6016484

