

Sound Bar User Manual

Operating Introduction

a. Place the Soundbar on flat surfaces. Alternatively, you can wall mount the Soundbar with the screws provided. This Soundbar can be connected to play sound in three different ways:

1. Connect to your Television Headphone Socket
2. Connect to any Bluetooth enabled device
3. Connect to a USB Drive (stick) loaded with music files

b. Cable and external devices connection arrangements:

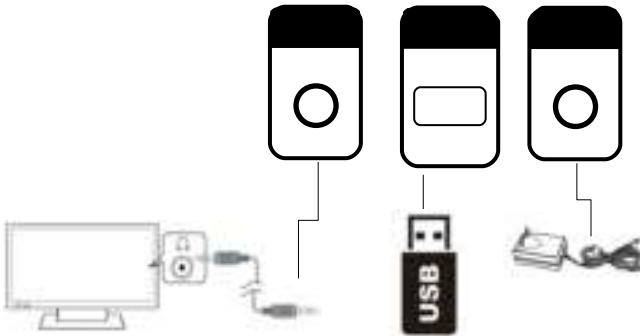

c. At the right hand side of the Sound Bar are the manual control buttons:



Press  Mode for **Power On/Standby**.

Hold  Mode to change the **mode** between: **Line In -> Bluetooth -> USB Drive**

Press  / MUTE for **Pause/Play**.

Hold  / MUTE for **Mute / No Mute**.



Press VOL+ / ►►I for **Volume up**.

Hold VOL+ / ►►I for **Next USB Drive Song**.

Press VOL- / I◀◀ for **Volume down**.

Hold VOL- / I◀◀ for **Previous USB Drive Song**.

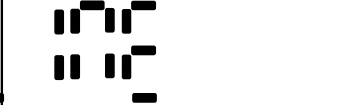
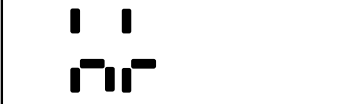
d. Front LED Display showing the different input modes

	Line In
	Bluetooth
	USB drive when USB Drive in (no USB drive will flash Led and skip to next mode in seconds)

Front indicator Lights:

Red dot: Soundbar in standby

bt font: Flashing means Bluetooth is waiting to pair with your Bluetooth enabled device.

bt lit and static means a Bluetooth device is paired.

e. Remote control buttons



	Power on / Standby
	Mute
+	Volume up
-	Volume down
I◀◀	Previous (USB drive audio)
▶▶	Next (USB drive audio)
▶	Play/Pause(USB drive audio)
	Repeat (USB drive audio)
EQ	Equalizer selection
Mode	Audio source selection



* EQ (Equalizer) Preset Music tone settings to suit personal taste

While playing music continually press the EQ button to toggle between the different presets

Display	EQ mode
Eq0	Normal
Eq1	Rock
Eq2	Pop
Eq3	Classic
Eq4	Jazz
Eq5	Country

Technical Specification

Power/Amps: Input: AC110~240V, 50/60Hz, Output: DC12V, 2.0A

Power consumption: 18W/Hour

Operating frequency range: 40hz-16Khz

Max output power: 20W (RED Standard)

Soundbar measurement: 60cm x 6cm x 6cm

Bluetooth name: DSB-2010

Packing List

- . Sound bar
- . Manual
- . 3.5mm to 3.5MM audio cable
- . Screws x 2
- . Remote control with batteries
- . Mains Power supply

Please notice - All products are subject to change without any notice. We take reservations for errors and omissions in the manual.

ALL RIGHTS RESERVED, COPYRIGHT DENVER ELECTRONICS A/S

DENVER®

www.denver-electronics.com

CE



Electric and electronic equipment contains materials, components and substances that can be hazardous to your health and the environment, if the waste material (discarded electric and electronic equipment) is not handled correctly.

Electric and electronic equipment is marked with the crossed out trash can symbol, seen above. This symbol signifies that electric and electronic equipment should not be disposed of with other household waste, but should be disposed of separately.

All cities have established collection points, where electric and electronic equipment can either be submitted free of charge at recycling stations and other collection sites, or be collected from the households. Additional information is available at the technical department of your city.

Hereby, Inter Sales A/S declares that the radio equipment type DSB-2010 is in compliance with Directive 2014/53/EU. The full text of the EU declaration of conformity is available at the following internet address: www.denver-electronics.com and then click the search ICON on topline of website. Write [modelnumber: DSB-2010](#). Now enter product page, and red directive is found under downloads/other downloads

Operating Frequency Range:40hz-16Khz

Max Output Power: 20W

DENVER ELECTRONICS A/S

Omega 5A, Soeften

DK-8382 Hinnerup

Denmark

www.facebook.com/denverelectronics