



Maverick

User Manual



Model: PFBD95

Thank you for choosing ProFlight.

Please read this user manual before using this drone and keep it safe for future reference.

CONTENTS

Safety.....	3
Battery Charging.....	4
Installing Controller Batteries.....	5
Transmitter Diagram.....	6
Folding the Arms.....	6
Fitting Propeller Guards.....	7
Propeller Installation.....	7
Preparing for First Flight.....	8
Binding of Radio Transmitter and Receiver.....	8
Flight Instructions.....	9
Flight Adjustment.....	10
Aircraft Functions & Features.....	11
Camera.....	13
App.....	14
Troubleshooting Guide.....	16
Support.....	17

SAFETY

Read the entire instruction manual and familiarise yourself with the product and all its features before operating. Failure to operate the product correctly can result in damage to the product, surroundings or even serious injury. This product is not a toy and must be operated with caution and common sense. It requires some basic mechanical knowledge. This product is not intended for use by children without direct adult supervision. This manual contains instructions for safety, operation and maintenance. It is essential to read and follow all the instructions and warnings in this manual prior to assembly, setup or use in order to operate correctly and avoid damage or serious injury.

- Not intended for use by children under 14 years of age. This is not a toy.
- Always operate your drone in open spaces away from vehicles, buildings, traffic and people.
- Always keep out of reach of children.
- Avoid exposure to water as moisture can cause damage to the electronics.
- Never operate your drone with low transmitter batteries.



The battery charger included with the drone has been designed to safely charge the Li-Po battery.

- Mishandling of Li-Po batteries can result in a fire, personal injury, and /or property damage.
- By handling, charging or using the included Li-Po battery you assume all risks associated with lithium batteries.
- If at any time the battery begins to balloon or swell, discontinue use immediately. If charging or discharging, discontinue and disconnect. Continuing to use, charge or discharge a battery that is ballooning or swelling can result in fire.
- Always store the battery at room temperature in a dry area for best results.

- Do not store battery or drone in a car or direct sunlight. If stored in a hot environment, the battery can be damaged or even catch fire.
- Never use any other type of battery charger other than the one supplied with the drone. Failure to charge the battery with a compatible charger may cause fire resulting in personal injury and/or property damage.
- Never exceed the recommended charge rate.
- When a Li-Po battery is discharged below 3.7V, the battery may be damaged and may no longer accept a charge. The drone will automatically land and become inactive when the battery reaches this level, this is to protect the battery.

Battery Charging

Use only the enclosed USB Li-Po charger to charge your battery.

Remove the battery from the battery compartment at the rear of the aircraft. Press down the release button on the underside of the aircraft and slide it out.

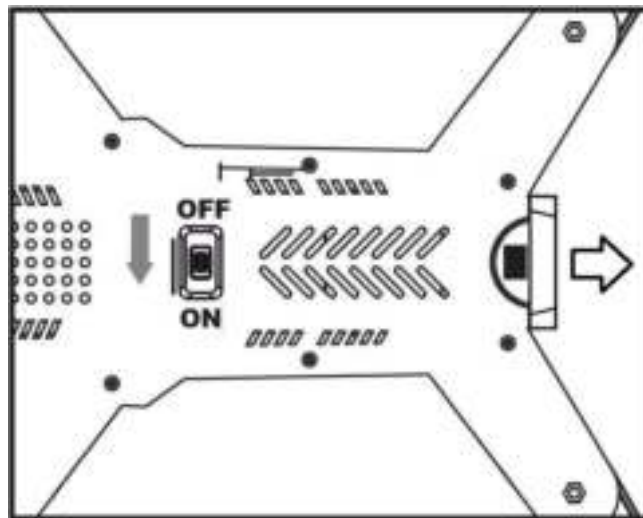



Plug the charger into a USB socket before attaching the battery.

When the charger is plugged into the USB slot and charging the LED will illuminate RED. When the battery is fully charged the LED will go out. Charging should take around 60-70 minutes. DO NOT leave the battery unattended whilst charging.

Installing the Controller Batteries

Unscrew the battery cover and insert 3 x AA Batteries, making sure the correct polarity is followed, before reattaching the battery cover

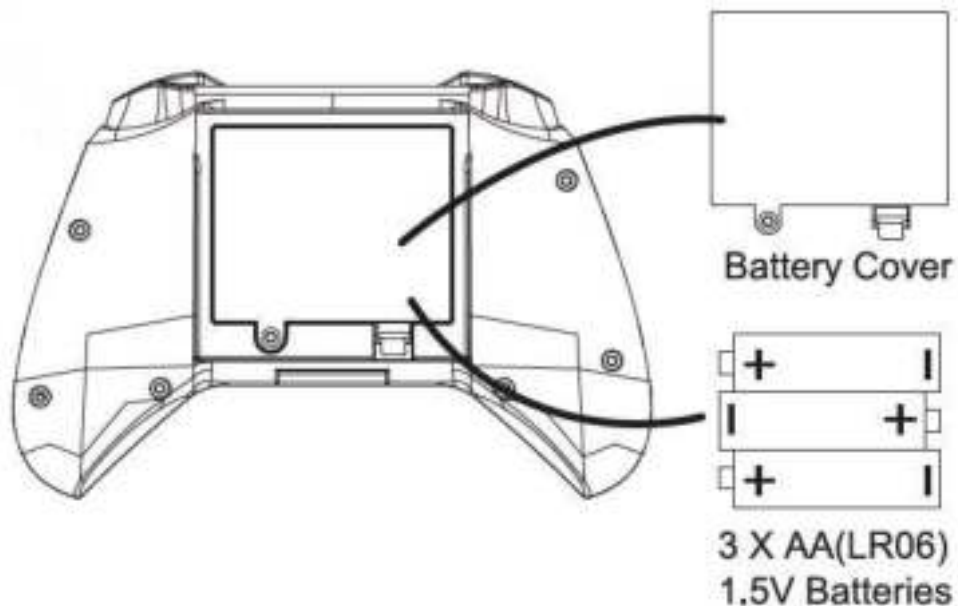

Transmitter Diagram

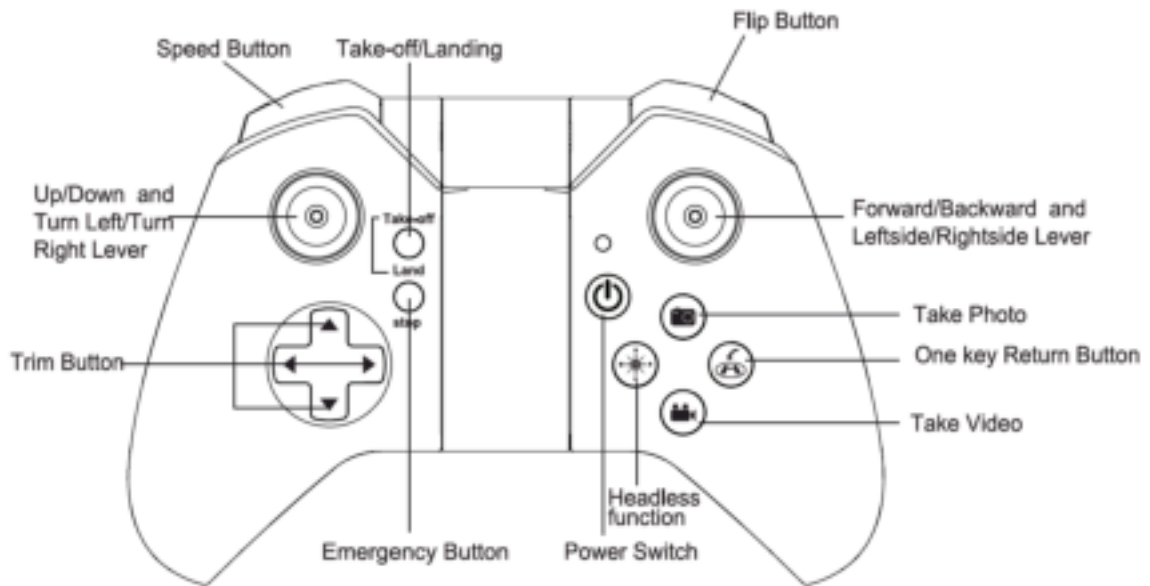

Folding the Arms

Please fold up the arms in the order 1 – 4 following the diagram below.

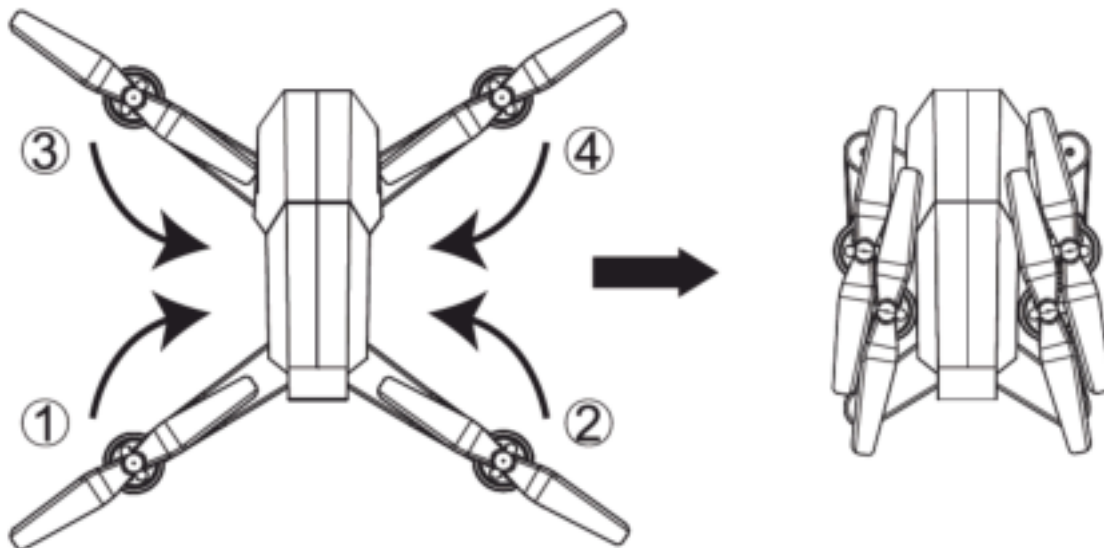

The arms are unfolded by following the reverse of the above, until the arms click into place.

Fitting Propeller Guards

Carefully remove the blanking plate by levering it out using a fingernail or blunt screwdriver. Push the propeller guide into the slot, pressing down where indicated on the centre diagram to prevent damage to the guard.

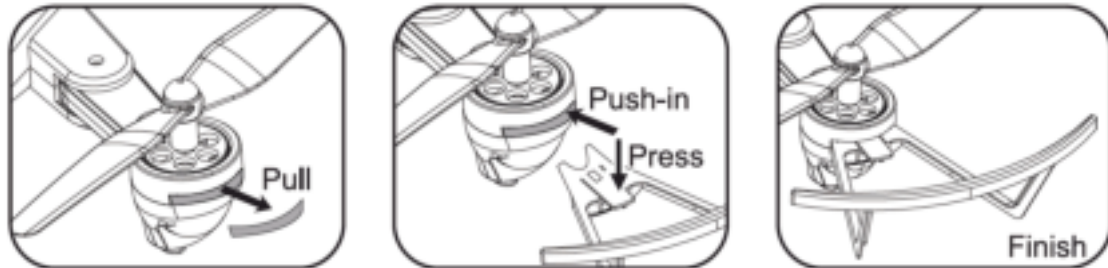

Propeller Installation

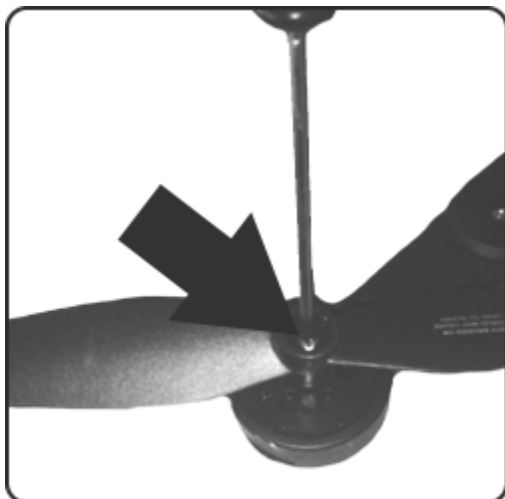

Insert the propeller over the motor spindle and use a screwdriver to tighten the screw, then push the silver cap into position over the screw.

Removal is the reverse of the above, first carefully removing the silver cap with a blunt object.

It is important for the correct blade to be placed on the correct motor or the aircraft will not fly correctly. Each blade is marked with an A or B on the underside to indicate which motor it corresponds to.

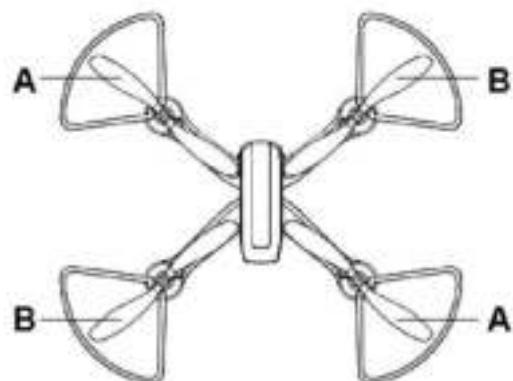

Preparing for First Flight

1. Make sure both the transmitter and aircraft batteries are sufficiently charged.
2. Find a suitable place to fly the aircraft, away from people, buildings and vehicles.
3. Make sure the throttle stick is centred before turning on the transmitter.

Binding of Radio Transmitter & Receiver

1. Place the aircraft on a flat surface and insert the battery into the aircraft, place the drone on a level surface, and turn it on using the button on the underside

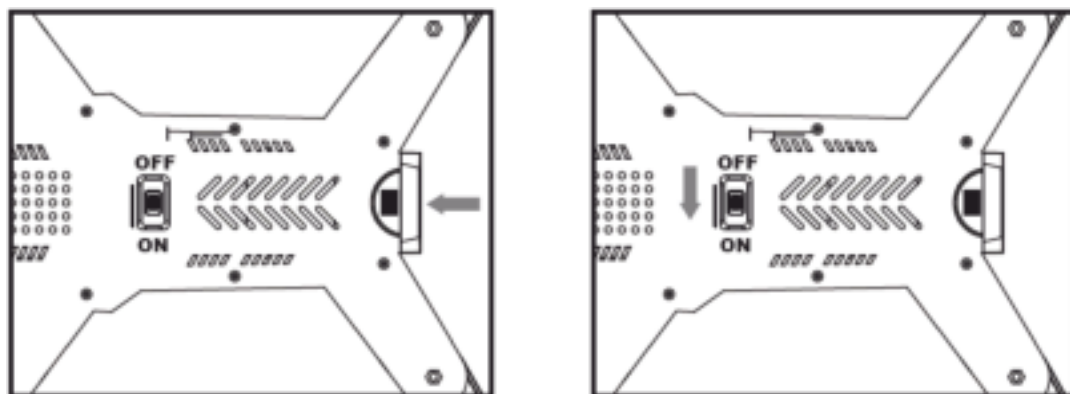

2. Turn on the controller.
3. The controller will beep twice, and the red LED will flash. Pair it to the drone by pushing the throttle stick to the top, it will beep, and then pull the throttle stick to the bottom.

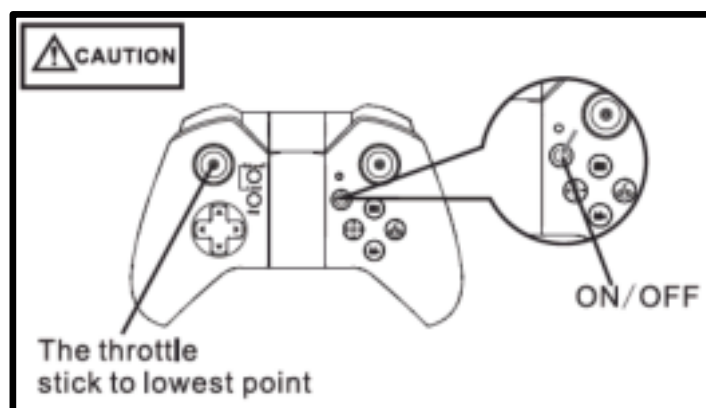

4. The long beep indicates it is paired and ready to fly

The aircraft can be flown using either the radio control supplied or by using the App on a smart device. For details on flying with the App, see page 14.

Flight Instructions

Before your first flight make sure you are familiar with the controls of the aircraft.

Left Joystick – Throttle & Rudder

Right Joystick – Elevator & Aileron

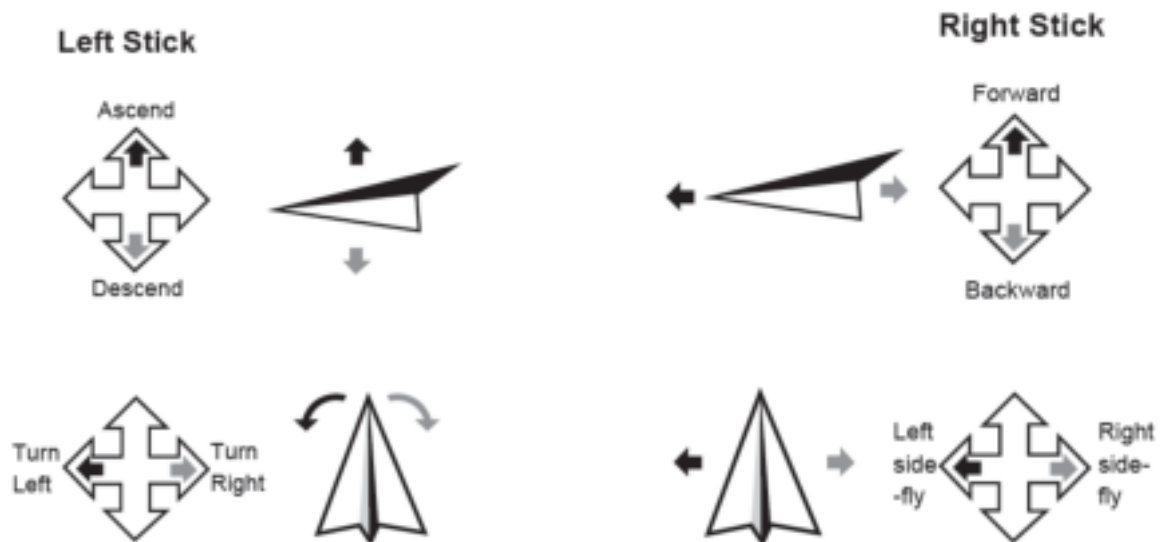







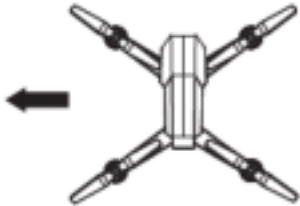

The aircraft can only take off and land by pressing the take off / land button (click once to take off and once to land). Once the aircraft is airborne it will hold a steady hover, you are now in control of the aircraft and can use the left and right sticks to control it.

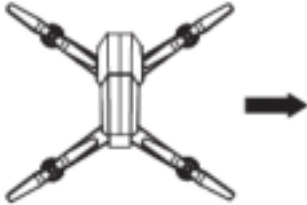
Note: Should the aircraft be left for a while with no control inputs it will go to sleep, simply press and hold the take off/land button to reactivate the aircraft.

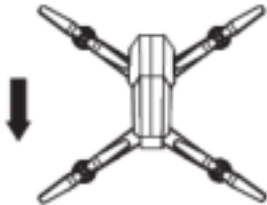
Flight Adjustment

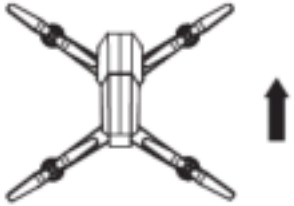
When you lift the Drone into the air, If the aircraft drifts in a particular direction you can trim the controls using the trim buttons. Select the trim key opposite the direction of drift. Trimming is always needed before your first flight.

	<p>If your Drone banks to the Left, keep pressing the Bank Left/Bank Right Trim Button to the Right till the Drone stops banking.</p>	
	<p>If your Drone banks to the Right, keep pressing the Bank Left/Bank Right Trim Button to the Left till the Drone stops banking.</p>	
	<p>If your Drone flies Backwards, keep pressing the Forward/Backwards Trim Button Up till the Drone stops flying Backwards.</p>	
	<p>If your Drone flies Forwards, keep pressing the Forward/Backwards Trim Button Down till the Drone stops flying Forwards.</p>	

Auto Trim



To recover the drone back to the original factory settings for trim. Press and hold the two levers in the direction shown on the diagram for a few seconds. The lights on the drone will start to flash to confirm this has completed.

Aircraft Functions and Features

One Key Return

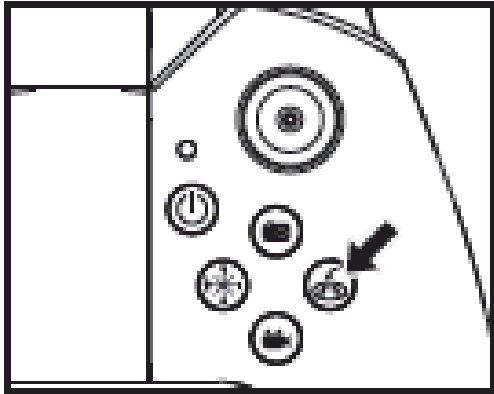

The aircraft can be made to return in a fixed direction by pressing and holding the return button. When the aircraft is turned on it will remember the direction it is oriented and upon activation of the Smart Return feature it will fly back in that direction.

NOTE: Be careful to orientate the aircraft with the rear tail facing towards you if you

want the aircraft to fly back towards you using the smart return mode. You can retake full control of the aircraft at any time by moving the control sticks. The aircraft will not return to where it started, it will simply move in the direction it was orientated when turned on.

Headless Flight

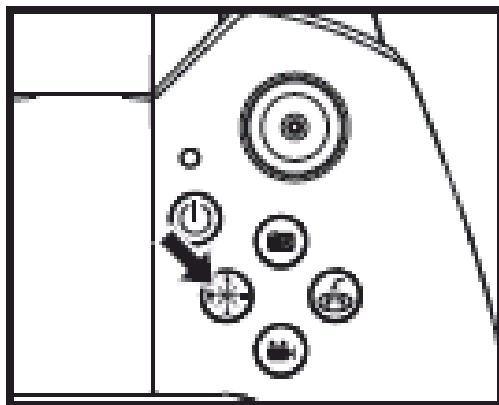

The aircraft can be made to fly in Headless Flight by pressing the headless flight button. This will make the aircraft fly without a front or rear. It will fly in the orientation of the pilot. If you move the right joystick right, the aircraft will fly right. Move the joystick left and it will fly left. Move the joystick forwards and the aircraft will fly away from you and pull it

back to make it fly towards you. It does not matter which direction the drone is facing in headless mode.

360 Flip

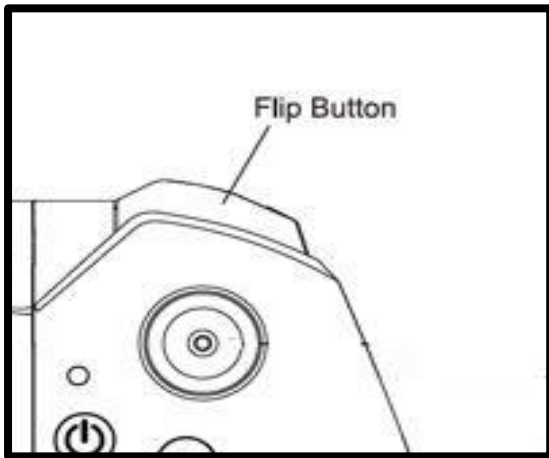

Before attempting a flip, please make sure the drone is at least 3 meters above the floor and 3 metres below a ceiling.

Press the flip button on the controller, it will make a bleep, then press the right lever in the direction you want the drone to flip.

Speed Control

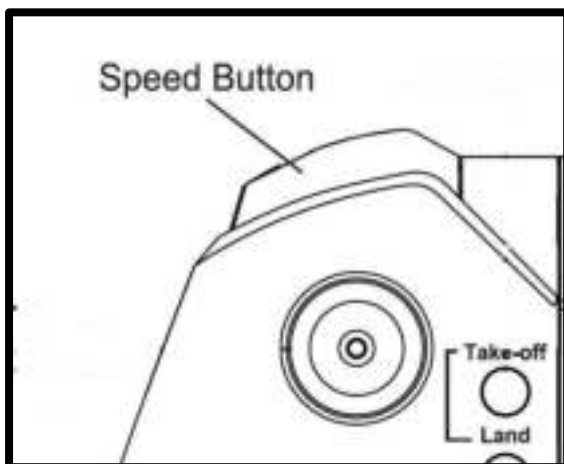

The drone has 3 speed settings. It will initially be set at 25%. By pressing the speed button the speed of the drone can be adjusted. The controller will bleep to indicate the speed it is set at after the button has been pressed.

25% - 1 Bleep, 50% - 2 Bleeps

100% - 3 Bleeps

Camera

The built in camera of the drone records direct to your smart device. See the next page for smart device application instructions.

When in flight, the two tail lights on the drone will flash once when a photo is taken, and will repeatedly flash when recording a video.

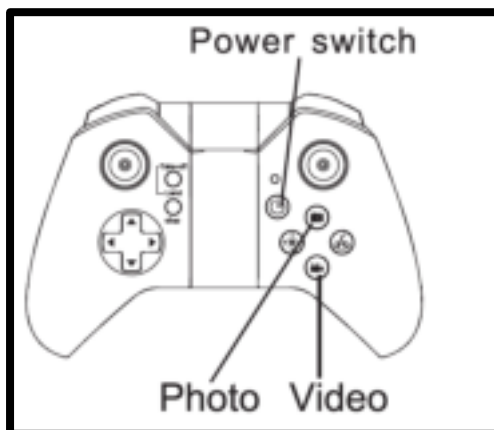

There are two buttons on the controller. The photo button, will save a snapshot directly to your smart devices gallery, and the video button will start recording a video. Pressing the video button again will stop the video.

Please Note: The video button **MUST** be pressed to stop the recording of the video, before the drone is landed, and drone turned off, otherwise and video will be lost.

APP

The camera App can be downloaded by scanning the below QR code or search for XSW UFO in your App Store:



Android



iOS

To connect the aircraft to your mobile device: turn on the aircraft and go to settings on your mobile device. Open the WiFi settings and search for a device starting with WiFiUFO-. Select it and wait for it to connect. Open the XSW UFO App and click "Play". This will lead you to the control screen and show the view of the camera. You can either use the on screen controls or the controller to control all aspects of the aircraft.

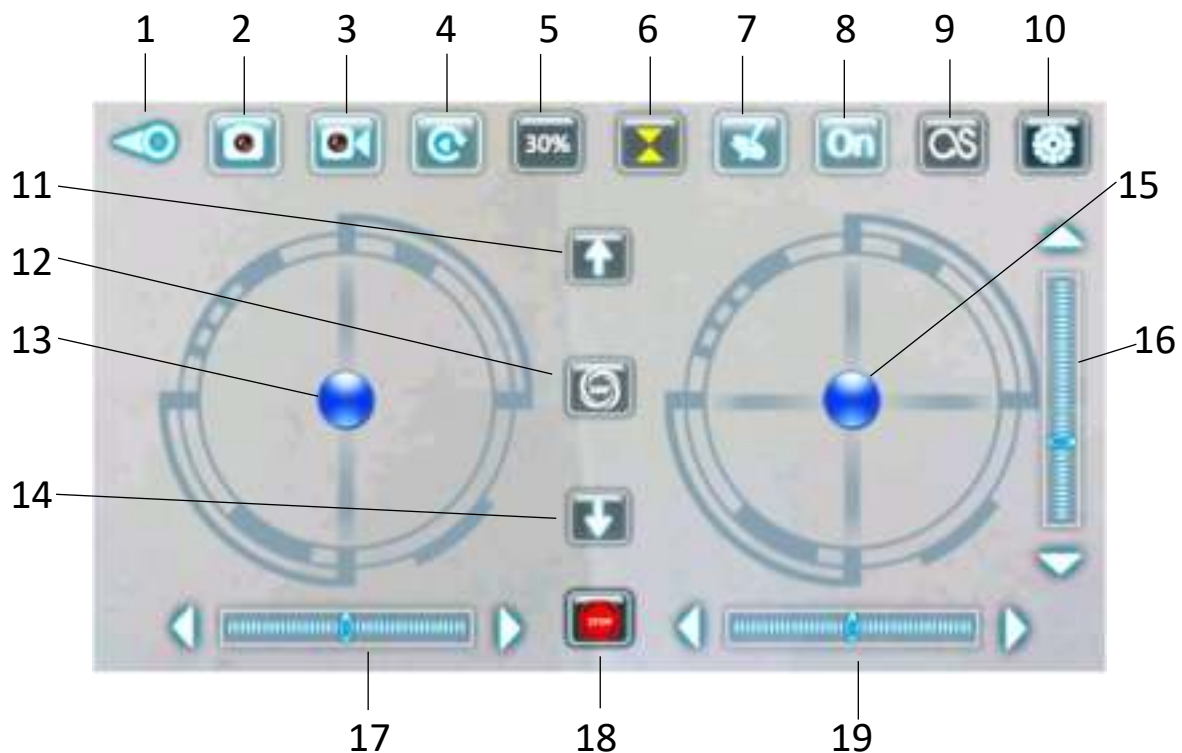

- | | |
|--|--|
| 1. Exit | 11. Take Off |
| 2. Take photo | 12. 360 Flip |
| 3. Start / Stop Recording Video | 13. Left control stick |
| 4. Video / Photo Playback | 14. Land |
| 5. Speed Settings | 15. Right control stick |
| 6. Toggle take off / Landing controls | 16. Pitch Trim |
| 7. Use phone's gyroscope for control | 17. Yaw Trim |
| 8. Toggle On Screen Controls | 18. Emergency Stop / Cut power to motors |
| 9. Maintain altitude, and control using left lever | 19. Roll Trim |
| 10. Settings | |

Note: Do not turn on the supplied remote control if you want to control the aircraft using the App. If you want to fly using the controller, the App can only be used for live view and photography, not controlling the aircraft.

Troubleshooting

	Problem	Cause	Solution
1	The lights on the aircraft are flashing but it does not respond to the control	<ol style="list-style-type: none"> 1. The aircraft and transmitter are not connected. 2. Insufficient battery power. 	<ol style="list-style-type: none"> 1. Repeat the connection procedure. 2. Recharge the battery.
2	The aircraft blades turn but it will not take off	<ol style="list-style-type: none"> 1. Insufficient battery power. 2. The blades are distorted. 3. Take off button not pressed. 	<ol style="list-style-type: none"> 1. Recharge the battery. 2. Replace the blades. 3. Press the take off button.
3	The aircraft shakes in flight	The blades are damaged/distorted	Replace the blades.
4	The aircraft won't fly using the App.	<ol style="list-style-type: none"> 1. Aircraft not connected to App. 2. Connection not done in correct order. 3. Main controller is turned on. 	<ol style="list-style-type: none"> 1. Reconnect using the instructions on page 14 2. Reconnect using the instructions on page 14 3. Aircraft can not fly on App when main controller is turned on. Turn off controller, reset aircraft, app and WiFi to reconnect to App
5	Camera not working in App	<ol style="list-style-type: none"> 1. Aircraft not connected to App. 	<ol style="list-style-type: none"> 1. Reconnect using the instructions on page 14



Disposal: Do not dispose this product as unsorted municipal waste. Collection of such waste must be handled separately as special treatment is necessary

Recycling facilities are now available for all customers at which you can deposit your old electrical products. Customers will be able to take any old electrical equipment to participating civic amenity sites run by their local councils. Please remember that this equipment will be further handled during the recycling process, so please be considerate when depositing your equipment. Please contact the local council for details of your local household waste recycling centres.

UK Support

<http://www.proflightuk.co.uk/support/>

If you have been through the troubleshooting, and the unit is failing to operate, our service line can be contacted on: 0871 971 3141

Office hours: 9AM - 5PM Monday to Friday

www.proflightuk.co.uk
Unit 2, The Nursery
Berristow Lane
South Normanton
Derbyshire, DE55 2FX