



BROTHERS4CHANGE
Helping Others Made Easy

01

Brothers4Change®
Phone Holder

12

Brothers4Change®
Telefoonhouder

23

Brothers4Change®
Support de téléphone

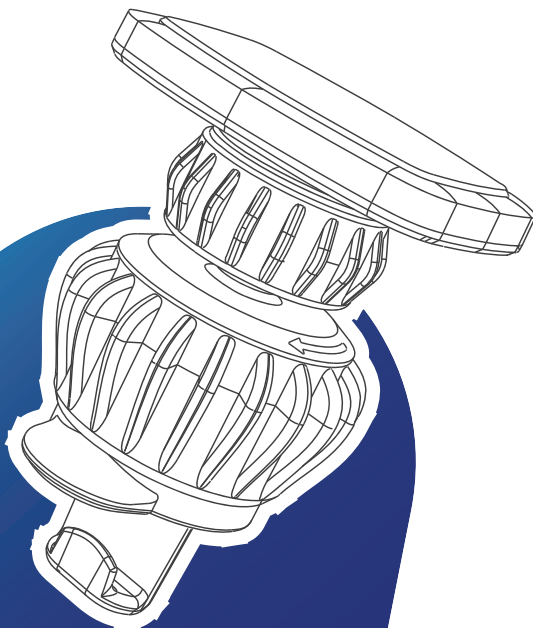



BROTHERS4CHANGE
Helping Others Made Easy

Brothers4Change® Phone Holder

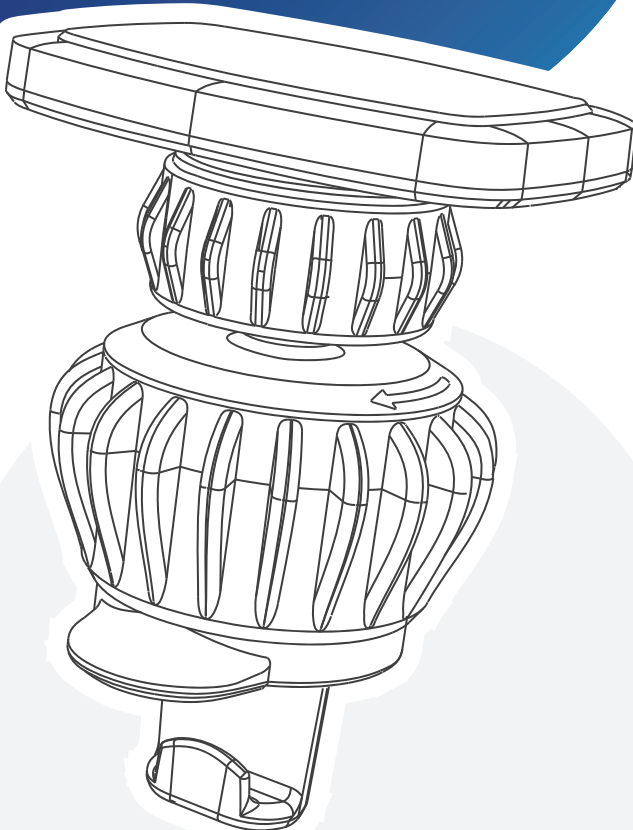



TABLE OF CONTENTS

About Brothers4Change® 03

Accessory list card 04

Product structure 04

Installation instructions 05

Product usage 07

Specifications 08

Precautions 09

Our other products 10

Brothers4Change® Phone Holder



ABOUT BROTHERS4CHANGE®

As two brothers, we created Brothers4Change with the intention of making it easier to help others. We do this by offering you the opportunity to purchase everyday products created with sustainability and humanity in mind.



Built to last

Premium materials - Simple designs - Products that can stand the test of time.



Ethical impact

We are committed to making education more accessible by using 10% of our profit for educational projects in developing countries.



Thoughtful materials

We are striving towards the creation of CO2 neutral products.

ACCESSORY LIST CARD

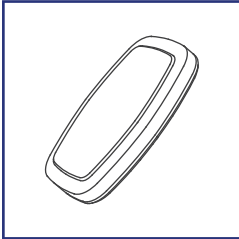

Magnetic head

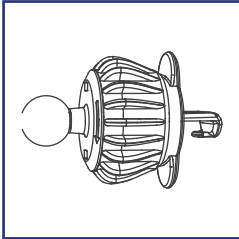

Hook clip

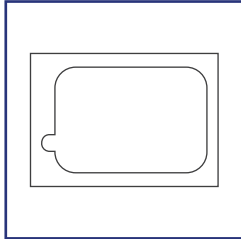

Square PE foil

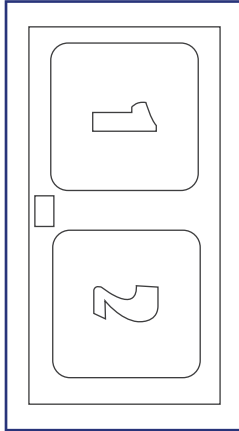

Tissue pack

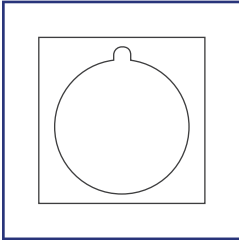

Round PE foil

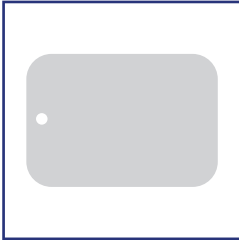

Square iron plate

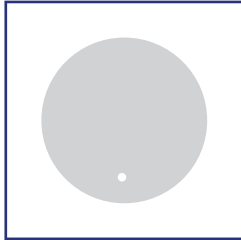

Round iron plate

PRODUCT STRUCTURE

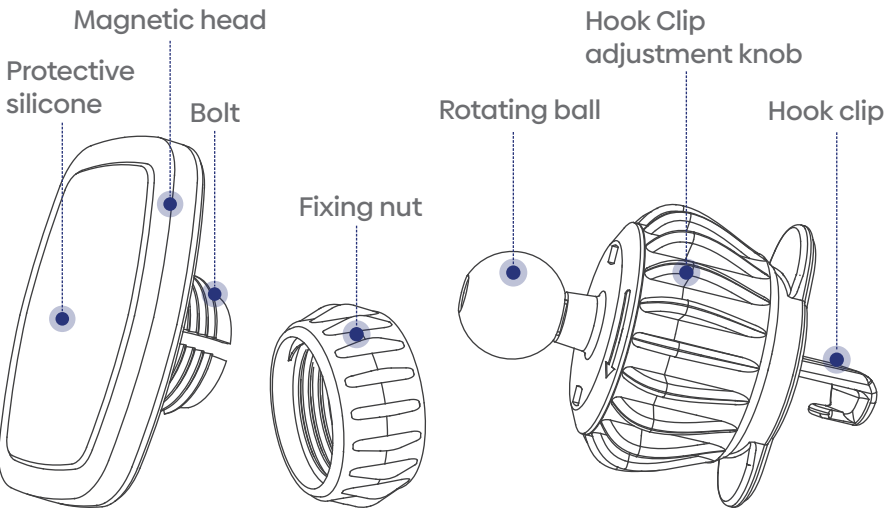

INSTALLATION INSTRUCTIONS

STEP 1

Loosen the fixing nut.

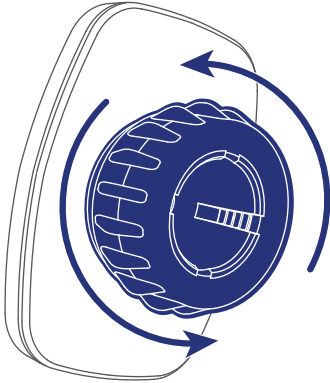

STEP 2

Insert the rotating ball through the fixing nut into the bolt.

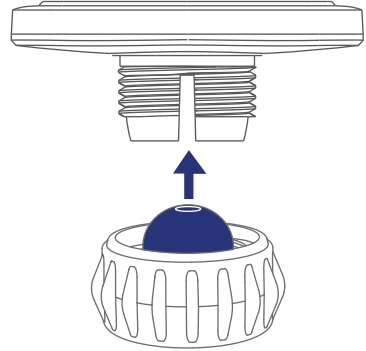

STEP 3

Tighten the fixing nut.

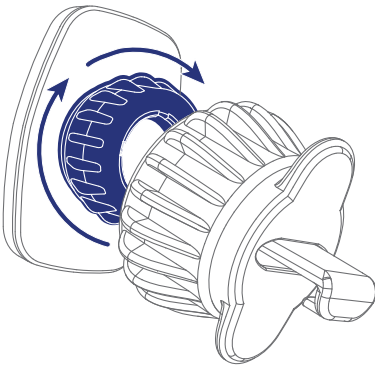

STEP 4

Turn the hook clip adjustment knob. Adjust the hook clip to the greatest length.

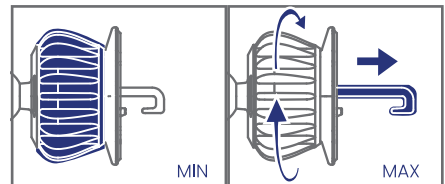

✔ STEP 5

Hook the clip down into the blade. Turn the adjustment knob on the hook clip to firmly secure the blade.

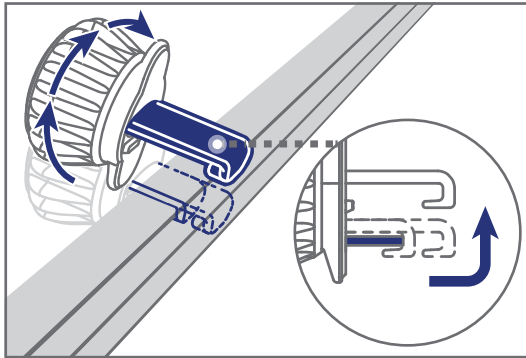
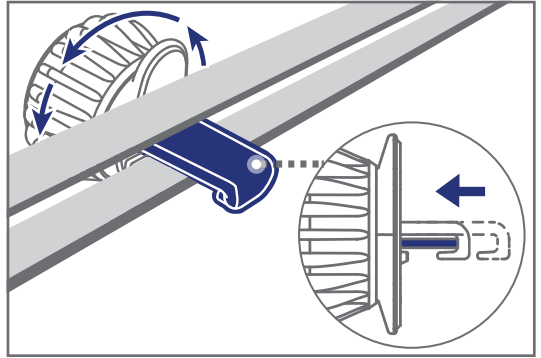

✔ STEP 6

When removing, loosen the hook clip adjustment knob to leave the phone mount from the blade.

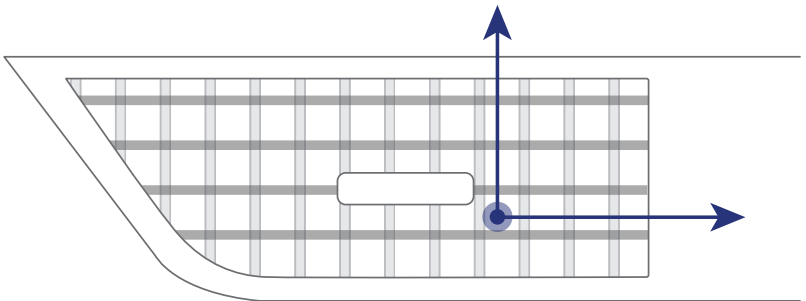

✔ TIP

If there is a problem when installing or removing the phone mount, please adjust the inner blade and outer blade of the air vent to be perpendicular to each other.

PRODUCT USAGE

✓ STEP 1

Open the tissue pack.

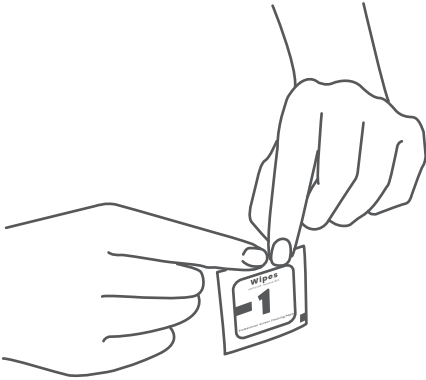

✓ STEP 2

Wipe the back of your device with the wet tissue. Dry it afterwards with a dry tissue.



✓ STEP 3

Tear off the foil from the iron plate and stick it on the back of the phone or on the phone case.

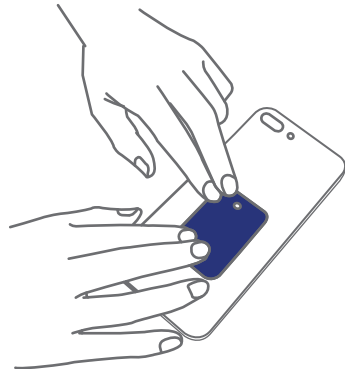
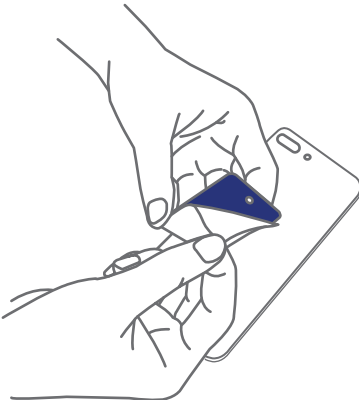

❖ **STEP 4**

It is not recommended to place the iron plate between the back of the phone and the phone case.

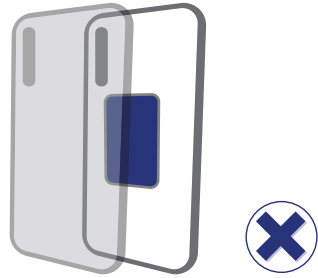

❖ **STEP 5**

If the back of the phone or the phone case is made out of glass, after wiping it clean, you should first stick the PE foil and then the iron plate.

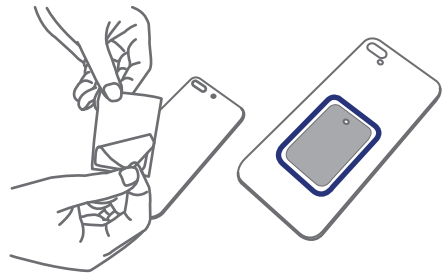

SPECIFICATIONS

- ❖ **Name:** Brothers4Change magnetic car phone holder
- ❖ **Size:** 4.9CM*3.6CM*6.5CM
- ❖ **Weight:** 49.6g
- ❖ **Model:** B4C 9
- ❖ **Applicable position:** Air vent
- ❖ **Material:** ABS + aluminum alloy + TPU + epoxy resin
- ❖ **Applicable blade width:** 11mm-19mm
- ❖ **Applicable blade thickness:** <3mm

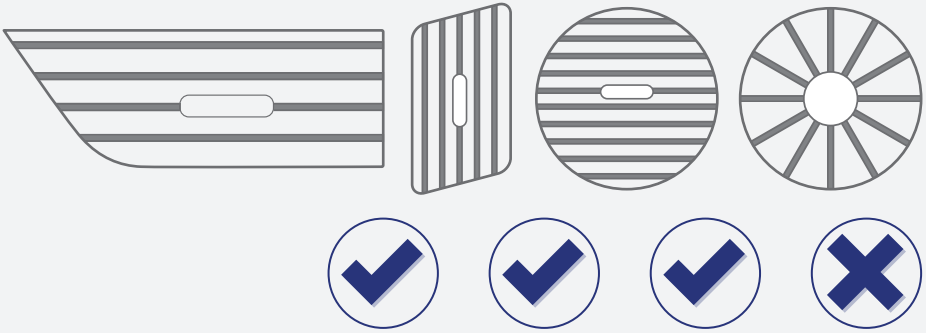

PRECAUTIONS

1. This product is suitable for all horizontal and vertical air vents and some circular air vents.
2. Please confirm whether the product is suitable for the width of the air vent blade of your vehicle.
3. If the back of the phone case is uneven, it is not recommended to use it.
4. If the size of your phone is relatively large, it is recommended to use the “square iron plate”.
5. If you are experiencing any troubles while installing the Brothers4Change car phone holder, please contact us through: Info@brothers4change.com We will gladly assist you.

OUR OTHER PRODUCTS



Led reading lamp



Led reading lamp



pH meter



Fire Blanket



Led reading lights



Led reading lights



CO2 meter



BROTHERS4CHANGE
Helping Others Made Easy

As two brothers, we created Brothers4Change with the intention of making it easier to help others. We do this by offering you the opportunity to purchase everyday products created with sustainability and humanity in mind.



We still have a long way to go, but it is extremely satisfying to see our dream slowly becoming a reality.

So far, you have helped make education more accessible to hundreds of children, simply by purchasing quality products made with sustainability in mind.

We would like to thank you from the bottom of our hearts for your support. We could never have done it without your support and it is with you in mind that we strive to be the best at what we do.

Samuel & Jonas Smis
Founders, Brothers4Change®

**If you have any questions,
do not hesitate to contact us.**

 +32(0) 4 702 325 37
 info@brothers4change.com
 www.brothers4change.com

Follow us on social media!

 @brothers4change
 @brothers_4_change
 @brothers4change
 @brothers4change
 @brothers4change



BROTHERS4CHANGE
Helping Others Made Easy

Brothers4Change® Telefoonhouder

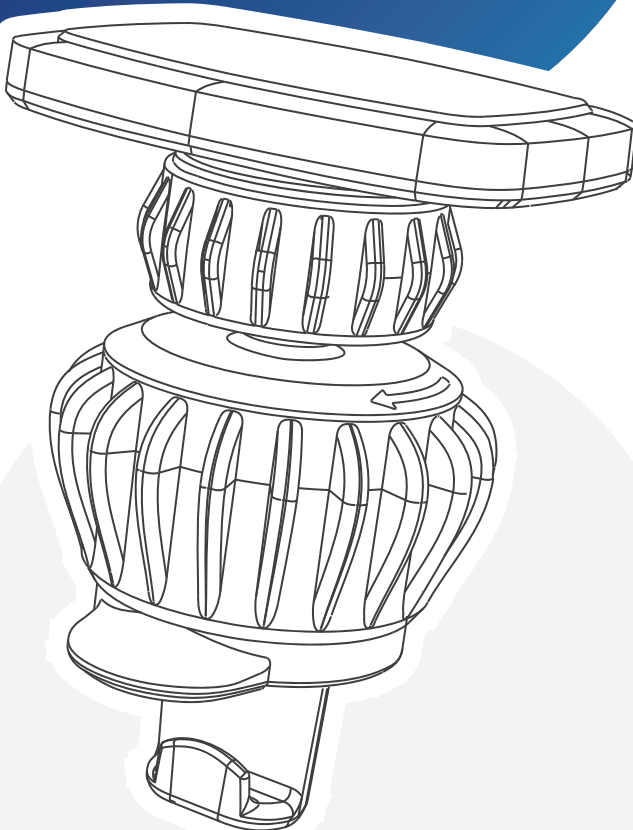



INHOUDSTAFEL

Over Brothers4Change® 14

Inhoud 15

Structuur van het product 15

Installatie instructies 16

Product gebruik 18

Specificaties 19

Voorzorgsmaatregelen 20

Onze andere producten 21

Brothers4Change® Telefoonhouder



OVER BROTHERS4CHANGE®

Mijn broer en ik zijn Brothers4Change gestart met de intentie om het helpen van anderen makkelijker te maken. Dit doen we door jou de mogelijkheid te bieden duurzame en betrouwbare producten te kopen die gemaakt zijn met respect voor de mensheid.



Duurzaam

Premium materialen -
Eenvoudige ontwerpen -
Producten die de tand des tijds
kunnen doorstaan.



Ethische impact

Wij zetten ons in om onderwijs
toegankelijker te maken door
10% van onze winst te gebruiken
voor onderwijsprojecten in
ontwikkelingslanden.



Doordachte materialen

Wij streven naar de creatie
van CO2-neutrale
producten.

INHOUD

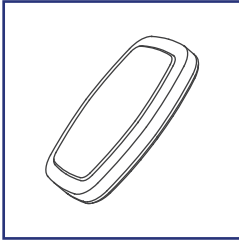

Magnetische kop

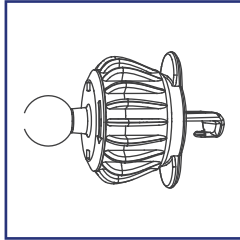

Haak clip

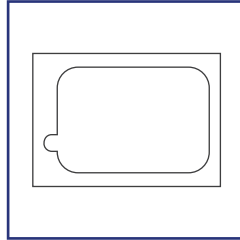

Vierkante beschermfolie

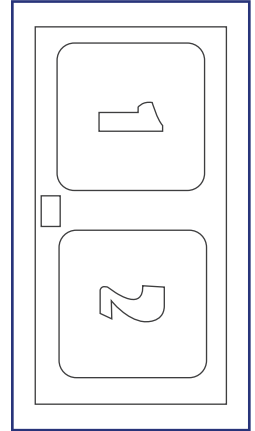

Schoonmaakdoekjes

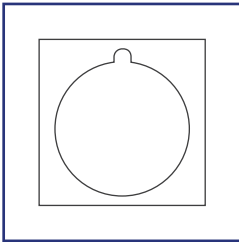

Ronde beschermfolie

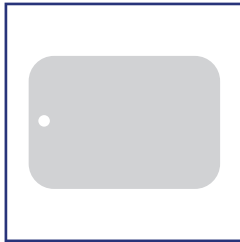

Vierkante ijzerplaat

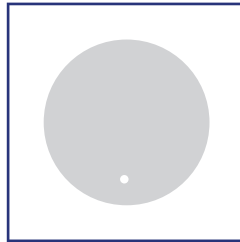

Ronde ijzerplaat

STRUCTUUR VAN HET PRODUCT

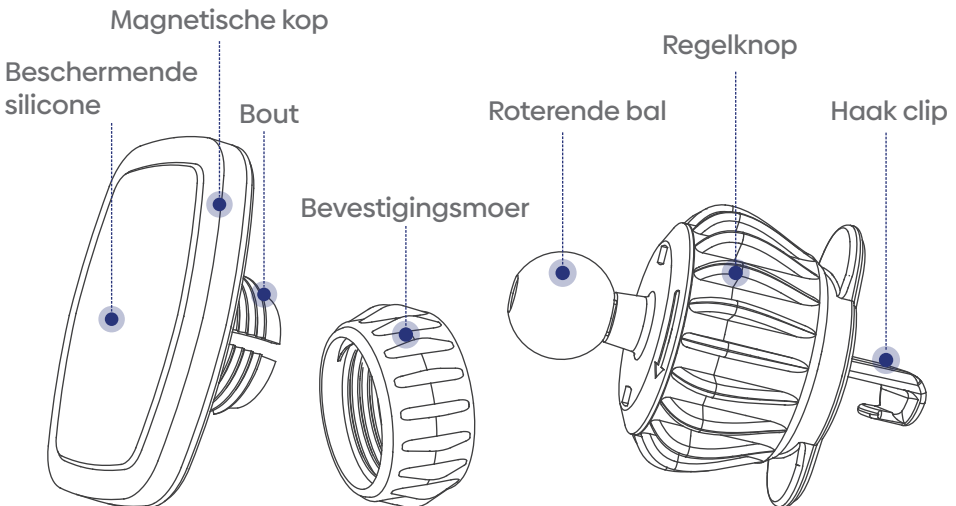

INSTALLATIE INSTRUCTIES

STAP 1

Draai de bevestigingsmoer los.

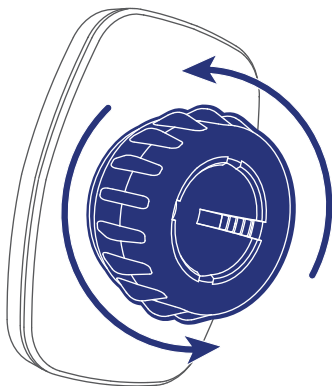

STAP 2

Steek de roterende bal door de bevestigingsmoer in de bout.

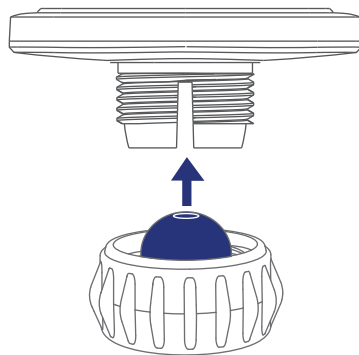

STAP 3

Draai de bevestigingsmoer vast.

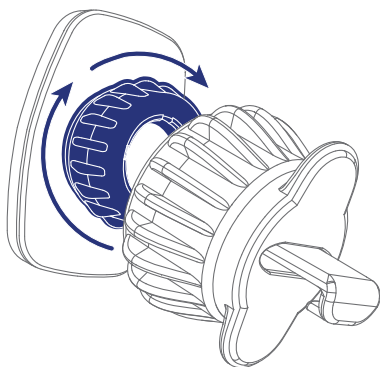

STAP 4

Draai aan de regelknop van de haakclip. Stel de haakclip in op de grootste lengte.

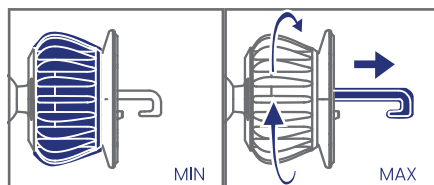

✓ STAP 5

Haak de clip vast in het blad. Draai aan de regelknop om de haakklem stevig vast te maken aan het blad.

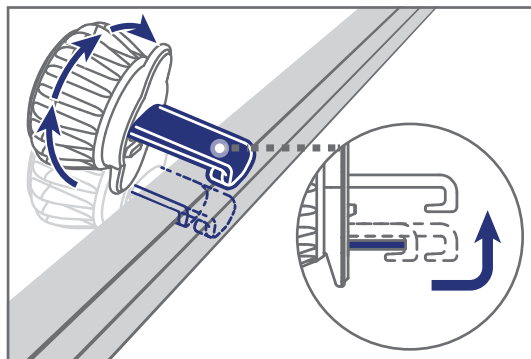
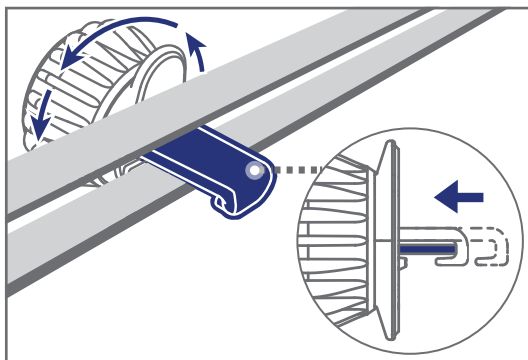

✓ STAP 6

Om de telefoonhouder te verwijderen draai je de regelknop los zodat de telefoonhouder niet langer aan het blad vasthangt.

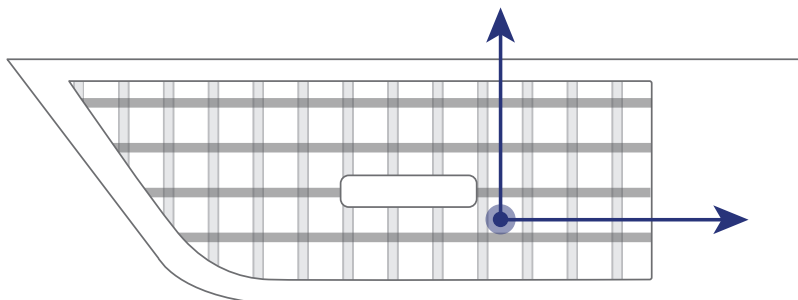

✓ TIP

Mocht er een probleem optreden bij het installeren of verwijderen van de telefoonhouder, zorg er dan voor dat de binnenste en buitenste bladen van de ventilator loodrecht op elkaar staan.

PRODUCT GEBRUIK

✓ STAP 1

Haal het doekje uit de verpakking.

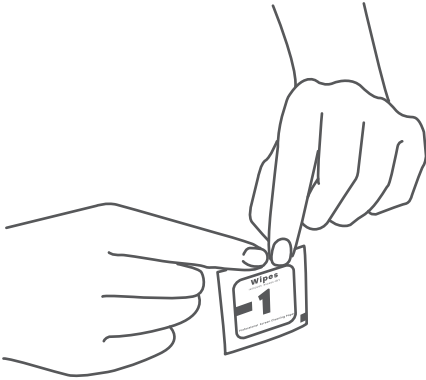

✓ STAP 2

Veeg de achterkant van het apparaat af met het natte doekje. Droog het daarna af met een droog doekje.



✓ STAP 3

Haal de folie van het ijzeren plaatje en plak het plaatje vervolgens op de achterkant van je telefoon of op het telefoonhoesje.

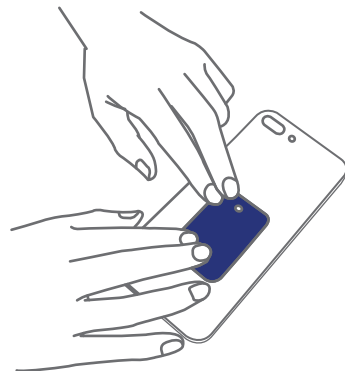
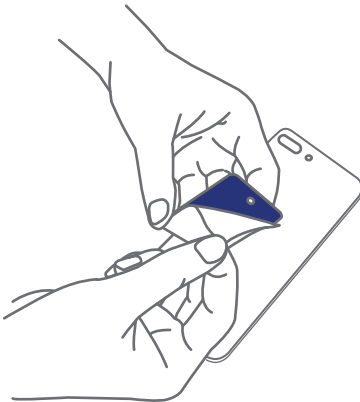

✓ **STAP 4**

Het wordt afgeraden om het ijzeren plaatje tussen de achterkant van de telefoon en het telefoonhoesje te plaatsen.

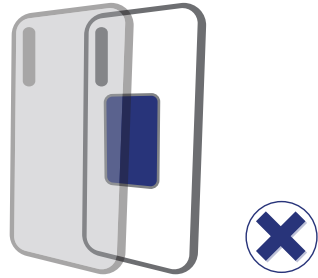

✓ **STAP 5**

Als de achterkant van de telefoon of het telefoonhoesje van glas is, moet je na het schoonvegen eerst de PE folie plakken en hierop de ijzeren plaat.

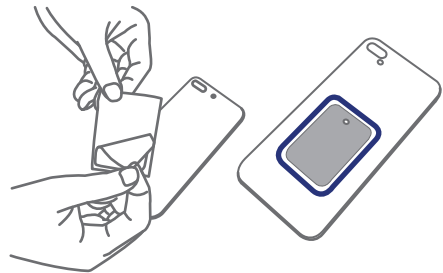

SPECIFICATIES

- ✓ **Naam:** Brothers4Change magnetische autotelefoonhouder
- ✓ **Grootte:** 4.9CM*3.6CM*6.5CM
- ✓ **Gewicht:** 49.6g
- ✓ **Model:** B4C 9
- ✓ **Toepasselijke gebruik:** Ventilatioerooster
- ✓ **Materiaal:** ABS + aluminiumlegering + TPU + epoxyhars
- ✓ **Toepasselijke breedte van het blad:** 11mm-19mm
- ✓ **Toepasselijke bladdikte:** <3mm

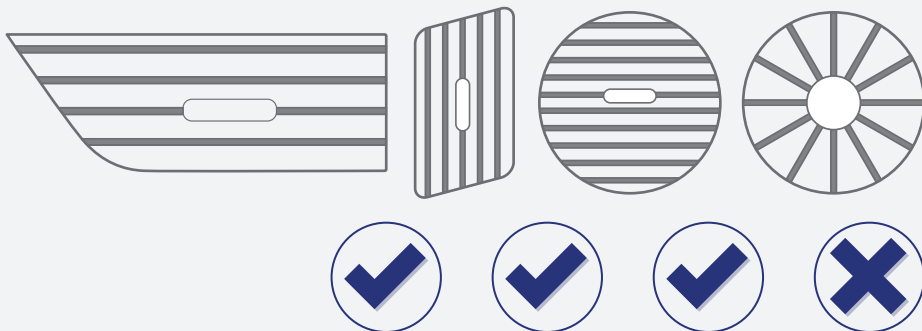

VOORZORGSMATREGELEN

1. Dit product is geschikt voor alle horizontale en verticale luchtroosters en sommige ronde luchtroosters.
2. Controleer of het product geschikt is voor de breedte van het luchtrooster van jouw voertuig.
3. Als de achterkant van je telefoonhoesje oneffen is, is het niet aan te raden dit hoesje te gebruiken.
4. Als je een relatief grote telefoon hebt, is het aanbevolen om de “vierkante ijzeren plaat” te gebruiken.
5. Mocht je problemen ondervinden tijdens het installeren van de Brothers4Change telefoonhouder, neem dan gerust contact met ons op via: Info@brothers4change.com Wij helpen je graag verder.

ONZE ANDERE PRODUCTEN



Led leeslamp



Led leeslamp



pH meter



Blusdeken



Leeslampen



Leeslampen



CO2 meter



BROTHERS4CHANGE
Helping Others Made Easy

Mijn broer en ik zijn Brothers4Change gestart met de intentie om het helpen van anderen makkelijker te maken. Dit doen we door jou de mogelijkheid te bieden duurzame en betrouwbare producten te kopen die gemaakt zijn met respect voor de mensheid.

We hebben nog een lange weg te gaan, maar het is enorm bevredigend om onze droom langzamerhand werkelijkheid te zien worden.

Tot nu toe heb jij bijgedragen aan het toegankelijker maken van onderwijs voor meer dan honderden kinderen, gewoon door nuttige kwaliteitsproducten te kopen die gemaakt zijn met een focus op duurzaamheid.

We willen je dan ook graag vanuit het diepste van ons hart bedanken om ons te steunen. Zonder jouw steun hadden we dit nooit kunnen doen en het is met jou in gedachten dat we ernaar streven de beste te zijn in wat we doen.

Samuel & Jonas Smis

Oprichters, Brothers4Change®

Aarzel zeker niet om ons te
contacteren indien je met vragen zit!

 +32(0) 4 702 325 37

 info@brothers4change.com

 www.brothers4change.com

Volg ons op sociale media!

 [@brothers4change](https://www.facebook.com/brothers4change)

 [@brothers_4_change](https://www.instagram.com/brothers_4_change)

 [@brothers4change](https://www.tiktok.com/@brothers4change)

 [@brothers4change](https://www.linkedin.com/company/brothers4change)

 [@brothers4change](https://www.youtube.com/brothers4change)



BROTHERS4CHANGE
Helping Others Made Easy

Brothers4Change® Support de téléphone

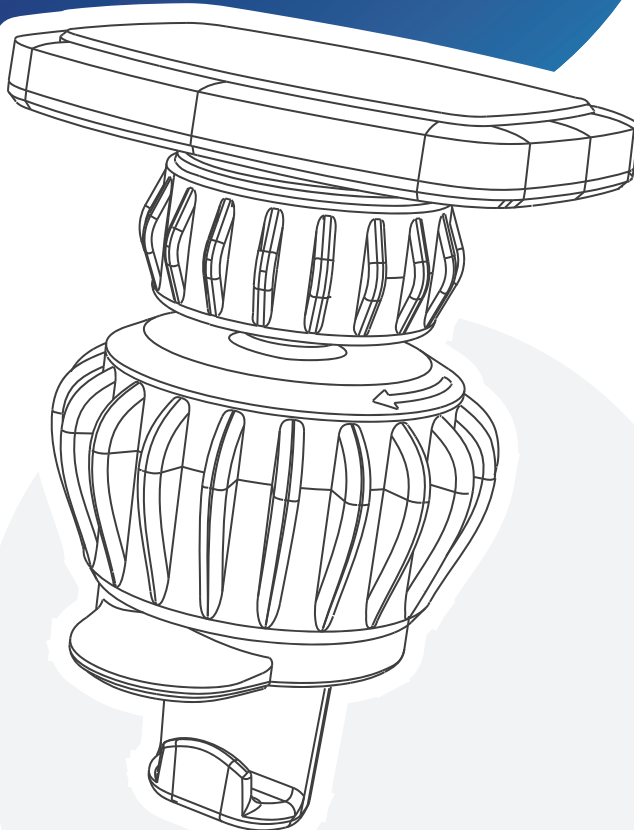



TABLE DE MATIÈRES

À propos de Brothers4Change® 25

Contenu 26

Structure du produit 26

Instructions d'installation 27

Utilisation du produit 29

Spécifications 30

Précautions 31

Nos autres produits 32

Brothers4Change®

Support de téléphone



À PROPOS DE BROTHERS4CHANGE®

En tant que deux frères, nous avons créé Brothers4Change avec l'intention de faciliter l'aide aux autres. Nous y parvenons en vous offrant la possibilité d'acheter des produits de tous les jours créés dans un souci de durabilité et d'humanité.



Construit pour durer

Des matériaux de haute qualité - des designs simples - des produits qui peuvent résister à l'épreuve du temps.



Impact éthique

Nous nous engageons à rendre l'éducation plus accessible en utilisant 10 % de nos bénéfices pour des projets éducatifs dans les pays en voie de développement.



Des matériaux réfléchis

Nous nous efforçons de créer des produits neutres en CO2.

CONTENU

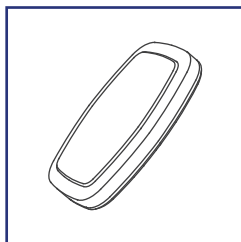

Tête magnétique

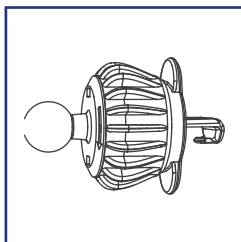

Clip de crochet

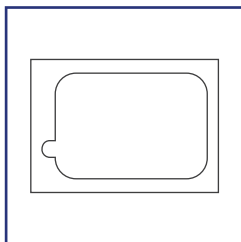

Film de protection carré

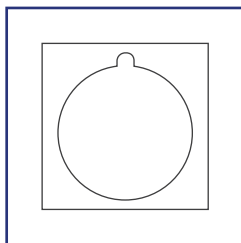

Film de protection rond

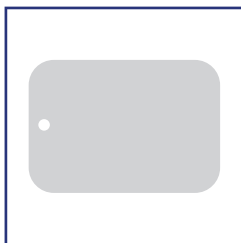

Plaque de fer carrée

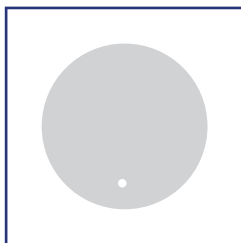

Plaque de fer circulaire

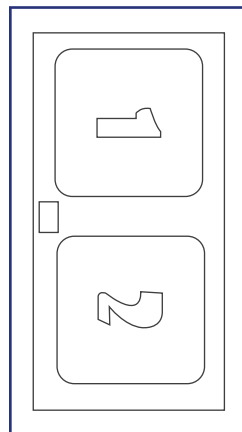

Lingettes de nettoyage

STRUCTURE DU PRODUIT

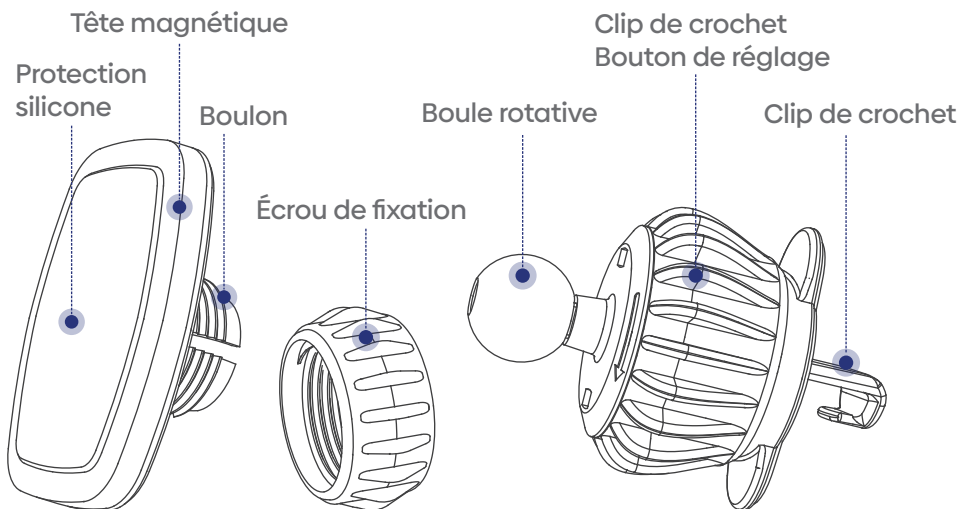

INSTRUCTIONS D'INSTALLATION

ÉTAPE 1

Desserrez l'écrou de fixation.

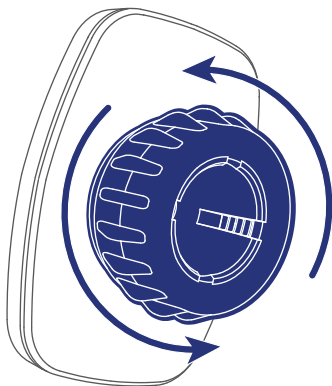

ÉTAPE 2

Insérez la bille rotative à travers l'écrou de fixation dans le boulon.

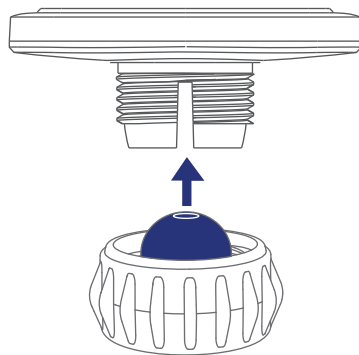

ÉTAPE 3

Serrez l'écrou de fixation.

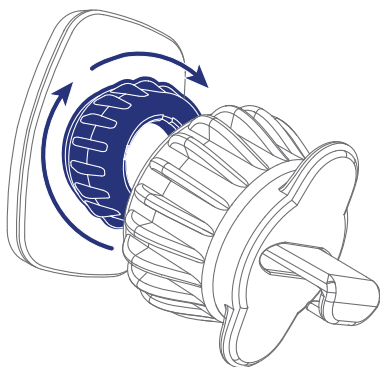

ÉTAPE 4

Tournez le bouton de réglage de la pince à crochet. Réglez le clip du crochet à la plus grande longueur.

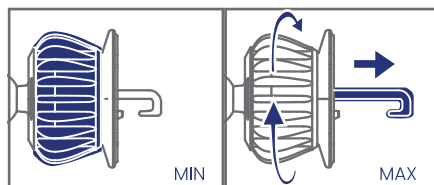

✓ ÉTAPE 5

Accrochez le clip dans la lame. Tournez le bouton de réglage pour fixer fermement la lame.

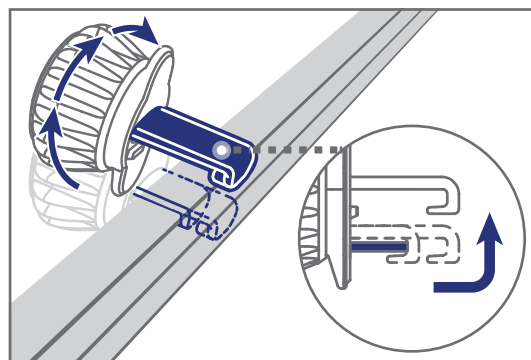
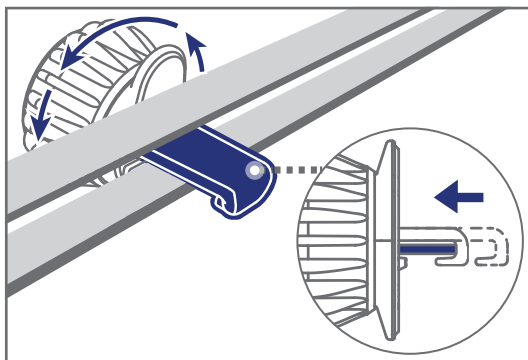

✓ ÉTAPE 6

Lors du retrait, desserrez le bouton de réglage de l'attache du crochet pour laisser le support du téléphone sur la lame.

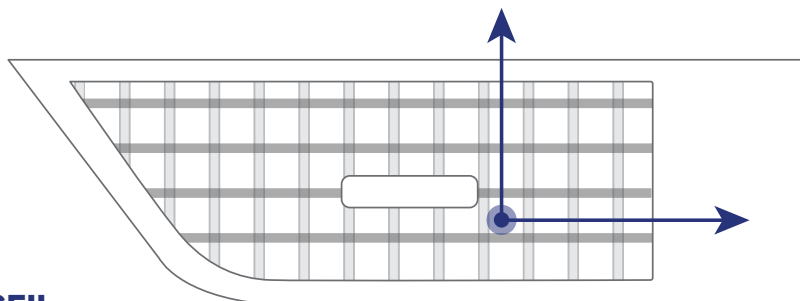

✓ CONSEIL

En cas de problème lors de l'installation ou du retrait du support de téléphone, veuillez ajuster la lame intérieure et la lame extérieure de l'aérateur pour qu'elles soient perpendiculaires l'une à l'autre.

UTILISATION DU PRODUIT

ÉTAPE 1

Ouvrez le paquet de mouchoirs.

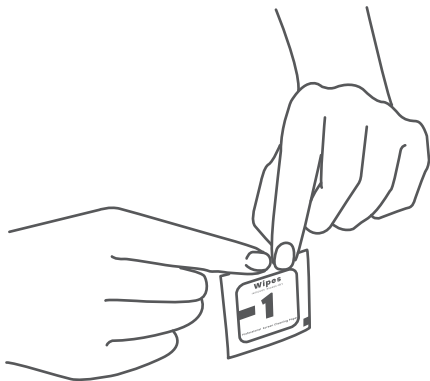

ÉTAPE 2

Essayez le dos de votre appareil avec le tissu humide. Séchez-le ensuite avec un mouchoir sec.

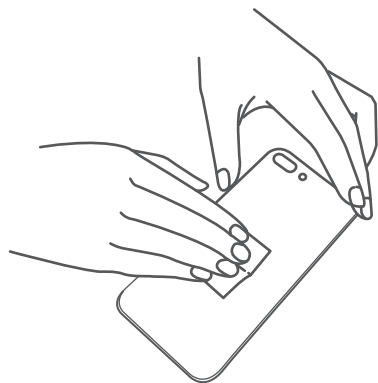

ÉTAPE 3

Déchirez la feuille d'aluminium de la plaque de fer et collez-la au dos du téléphone ou sur sa coque.

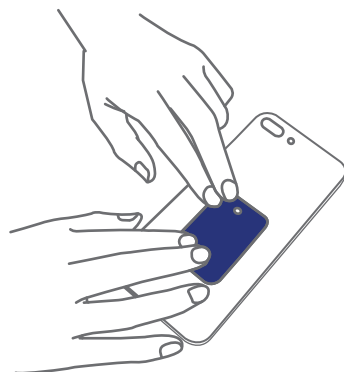
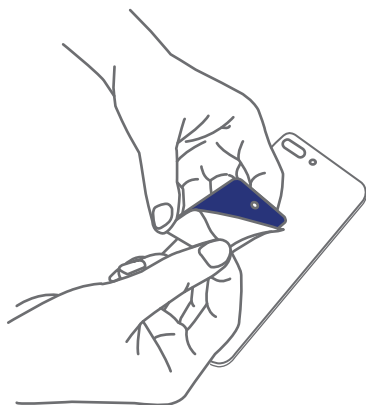

✔ ÉTAPE 4

Il n'est pas recommandé de placer la plaque de fer entre l'arrière du téléphone et la coque du téléphone.

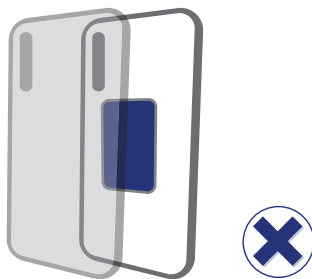

✔ ÉTAPE 5

Si le dos du téléphone ou la coque du téléphone est en verre, après l'avoir nettoyé, vous devez d'abord coller la feuille de protection et ensuite la plaque de fer.

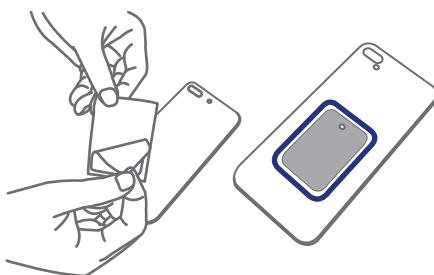

SPÉCIFICATIONS

- ✔ **Nom:** Brothers4Change support de téléphone magnétique pour voiture
- ✔ **Taille:** 4.9CM*3.6CM*6.5CM
- ✔ **Poids:** 49.6g
- ✔ **Modèle:** B4C 9
- ✔ **Position applicable:** grille de ventilation
- ✔ **Matériel:** ABS + alliage d'aluminium + TPU + résine époxy
- ✔ **Largeur de la lame applicable:** 11mm-19mm
- ✔ **Épaisseur de la lame applicable:** <3mm

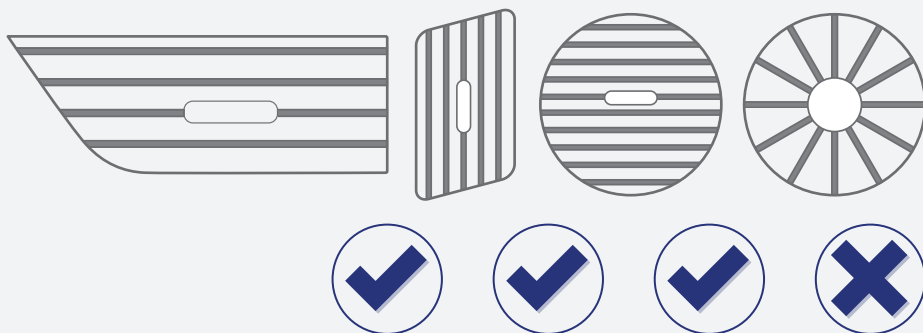

PRÉCAUTIONS

1. Ce produit convient à toutes les bouches d'air horizontales et verticales et à certaines bouches d'air circulaires.
2. Veuillez confirmer si le produit est adapté à la largeur de la lame de la bouche d'aération de votre véhicule.
3. Si le dos de la coque du téléphone est irrégulier, il n'est pas recommandé de l'utiliser.
4. Si la taille de votre téléphone est relativement grande, il est recommandé d'utiliser la "plaque de fer carrée".
5. Si vous rencontrez des difficultés lors de l'installation du support de téléphone de voiture Brothers4Change, veuillez nous contacter par :
Info@brothers4change.com Nous serons heureux de vous aider.

NOS AUTRES PRODUITS



Lampe de lecture



Lampe de lecture



pH-mètre



Couverture anti-feu



Lampe murale



Lampe murale



Compteur de CO2



BROTHERS4CHANGE
Helping Others Made Easy

En tant que deux frères, nous avons créé Brothers4Change avec l'intention de faciliter l'aide aux autres. Nous y parvenons en vous offrant la possibilité d'acheter des produits de tous les jours créés dans un souci de durabilité et d'humanité.

Nous avons encore un long chemin à parcourir, mais il est extrêmement satisfaisant de voir notre rêve devenir peu à peu réalité.

Jusqu'à présent, vous avez contribué à rendre l'éducation plus accessible à plus de centaines d'enfants, simplement en achetant des produits de qualité fabriqués dans une optique de durabilité.

Nous tenons à vous remercier du fond du cœur pour votre soutien. Nous n'aurions jamais pu le faire sans votre soutien et c'est en pensant à vous que nous nous efforçons d'être les meilleurs dans ce que nous faisons.

Samuel & Jonas Smis

Fondateurs de, Brothers4Change®

**Si vous avez des questions,
n'hésitez pas à nous contacter.**



+32(0) 4 702 325 37



info@brothers4change.com



www.brothers4change.com

Suivez-nous sur les médias sociaux !



@brothers4change



@brothers_4_change



@brothers4change



@brothers4change



@brothers4change