

# Revell F-14D Super Tomcat

04129-0312

© 2002 by REVELL, Inc. #0

PRINTED IN GERMANY

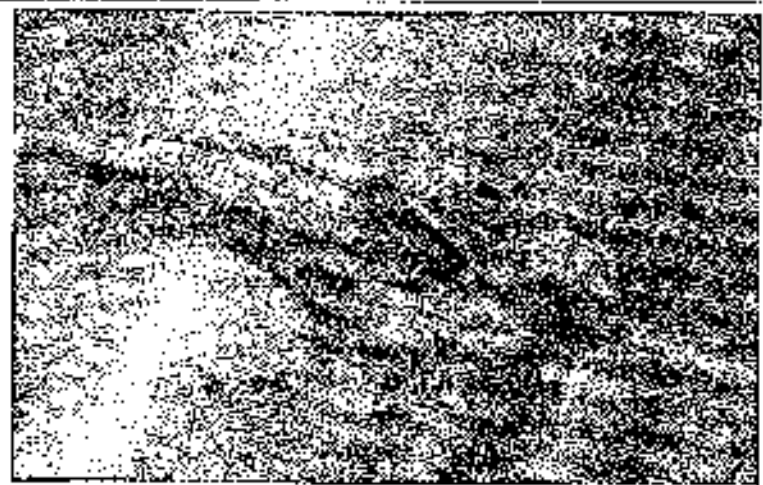

The F-14 Tomcat entered service in 1974 and has become one of the most successful fighter jets in the world. It was the last of the "swing-wing" fighters, designed to perform both air-to-air and air-to-ground missions. The F-14D is the two-seat, all-weather version of the Tomcat, featuring advanced avionics and the ability to carry a variety of weapons. It was the last fighter to be built by General Dynamics, which merged with Ford Aerospace to form Lockheed Martin in 1995. The F-14D was the last aircraft to be built by General Dynamics. It was the last fighter to be built by General Dynamics.

The F-14D is a two-seat, all-weather fighter jet. It was the last fighter to be built by General Dynamics. It was the last fighter to be built by General Dynamics.

The F-14D is a two-seat, all-weather fighter jet. It was the last fighter to be built by General Dynamics. It was the last fighter to be built by General Dynamics.

The F-14D is a two-seat, all-weather fighter jet. It was the last fighter to be built by General Dynamics. It was the last fighter to be built by General Dynamics.

- Technical Data:
- Wingspan (folded/unfolded): 11.00 m / 20.00 m
- Length: 18.00 m
- Height: 4.70 m
- Max. Speed: 2.4 Mach (2,800 km/h)
- Max. Altitude: 14,000 m
- Max. Weight: 18,000 kg

Wingspan (folded)	11.00 m
Wingspan (unfolded)	20.00 m
Length (overall)	18.00 m
Height	4.70 m
Engine type	2x General Electric F414-GE-100
Capacity	12,000 kg
Max. Take-off weight (MTOW)	21,000 kg
Max. Cruise weight (Cruise Weight)	18,000 kg
Max. Speed	2.4 Mach (2,800 km/h)
Max. Altitude	14,000 m
Max. Range	1,200 km (750 miles)
Max. Fuel Capacity	65,000 liters (17,200 gallons)
Max. Fuel Burn Rate	10,000 liters per hour (2,600 gallons per hour)

The F-14D is a two-seat, all-weather fighter jet. It was the last fighter to be built by General Dynamics. It was the last fighter to be built by General Dynamics.

The F-14D is a two-seat, all-weather fighter jet. It was the last fighter to be built by General Dynamics. It was the last fighter to be built by General Dynamics.

© 2002 by REVELL, Inc. #0







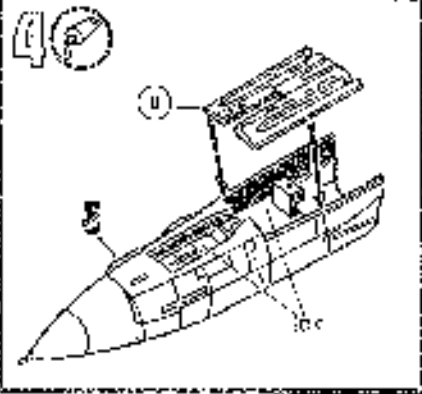
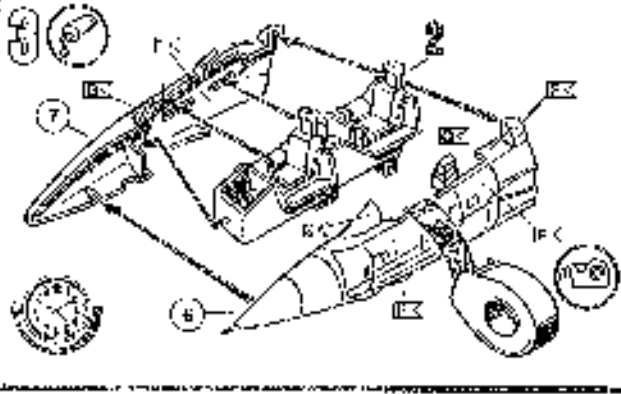
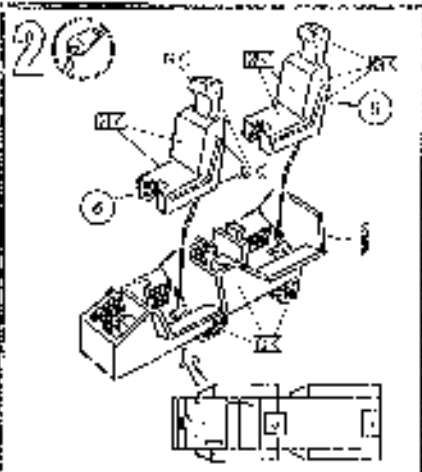
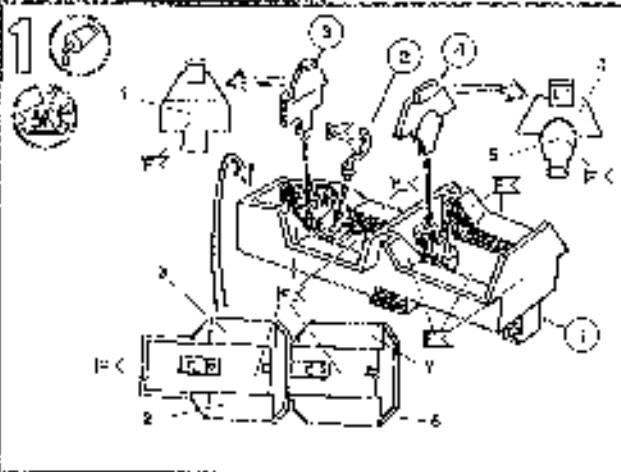
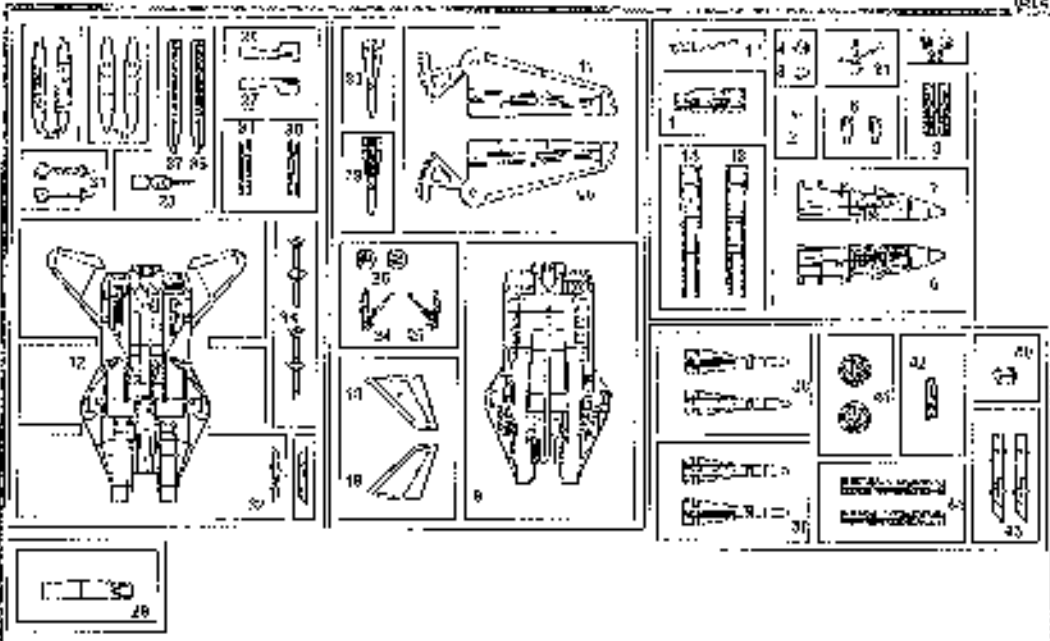

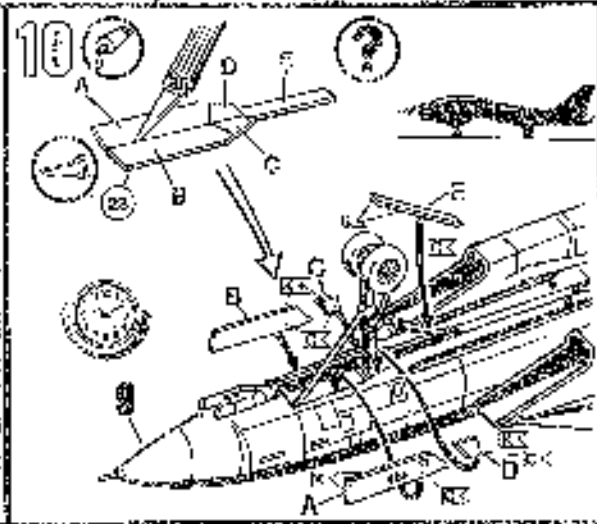
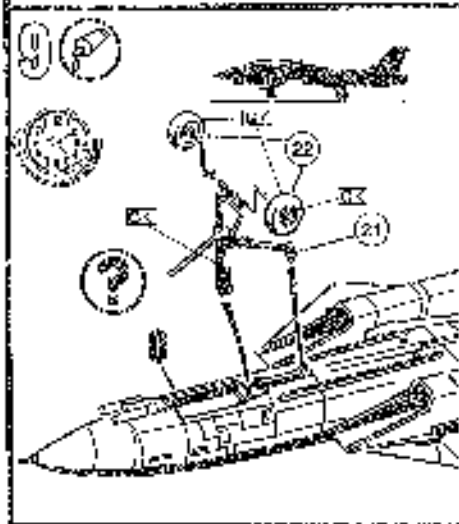
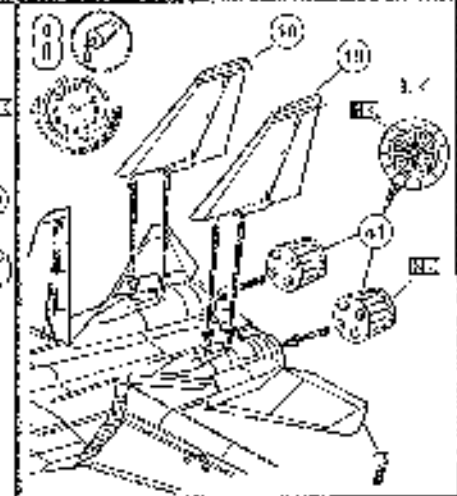
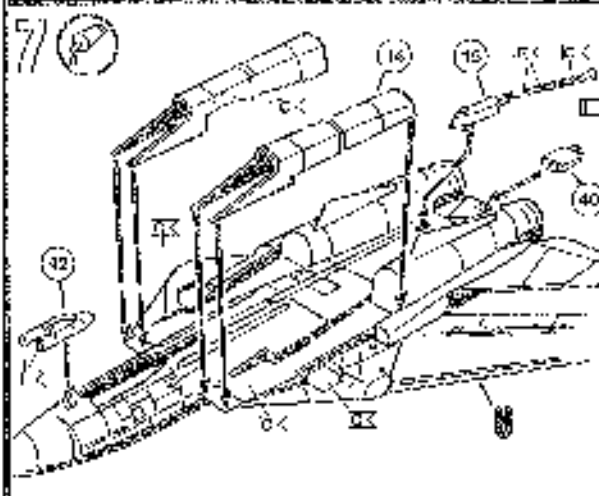
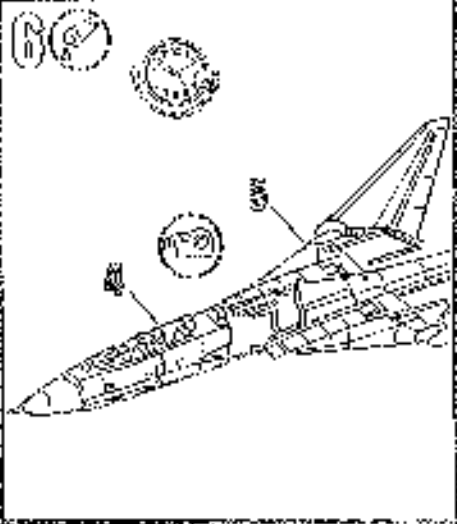
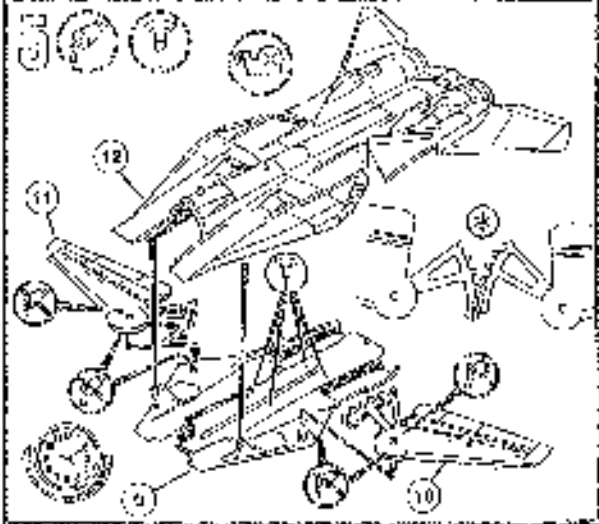

11

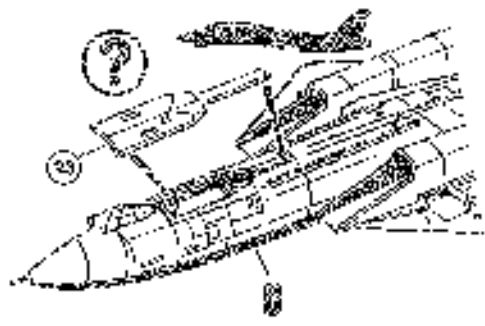

12

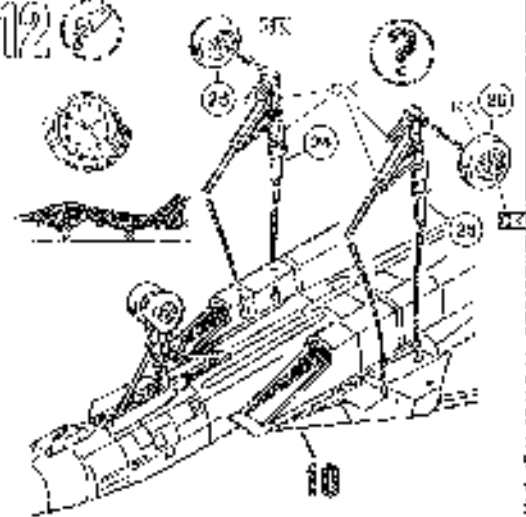

13

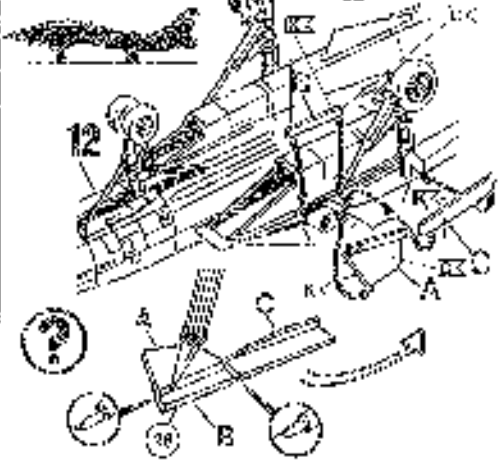

14

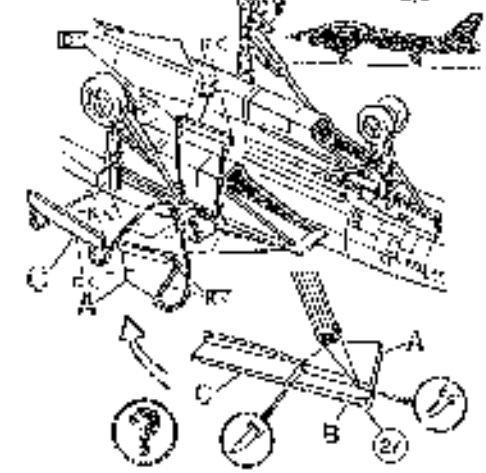



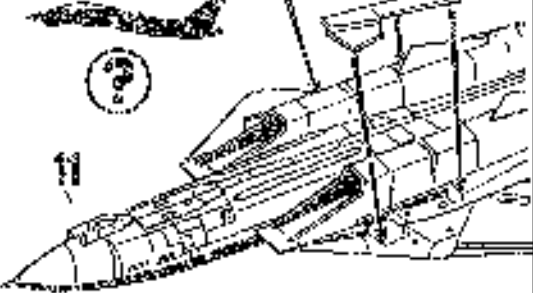

15

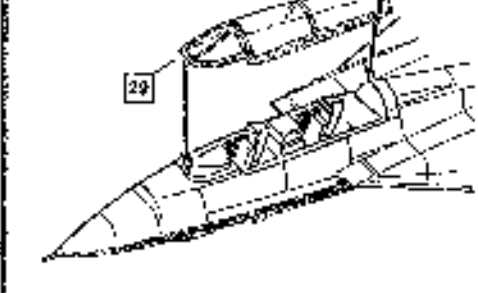



16









**17**  **AIM-9 Sidewinder**







   



 

**18**  **AIM-54 Phoenix**



    



 

**19**      





 



**20**  **AIM-41 Sidewinder**





  



 



**21**  **AIM-54 Phoenix**



   



 

**22**     

 

**2A**   **Tank**

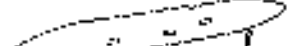





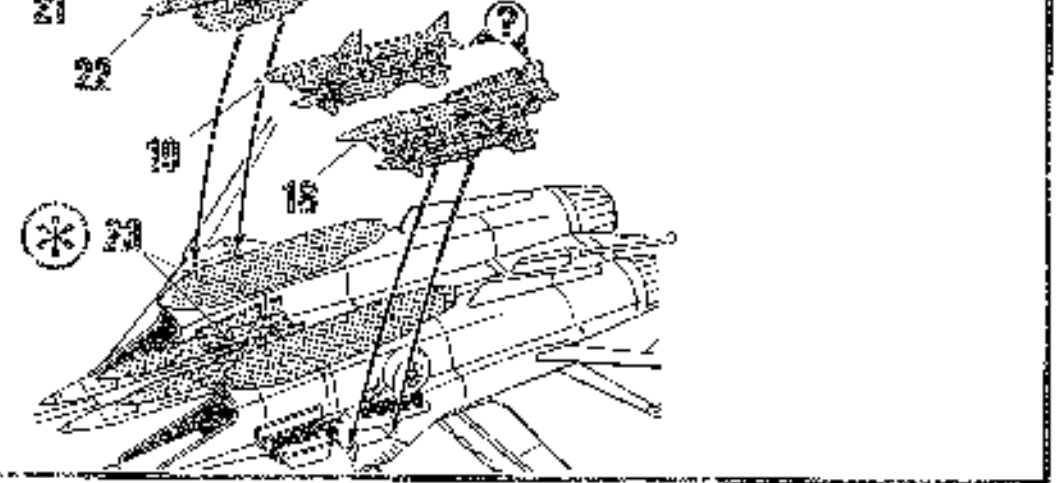
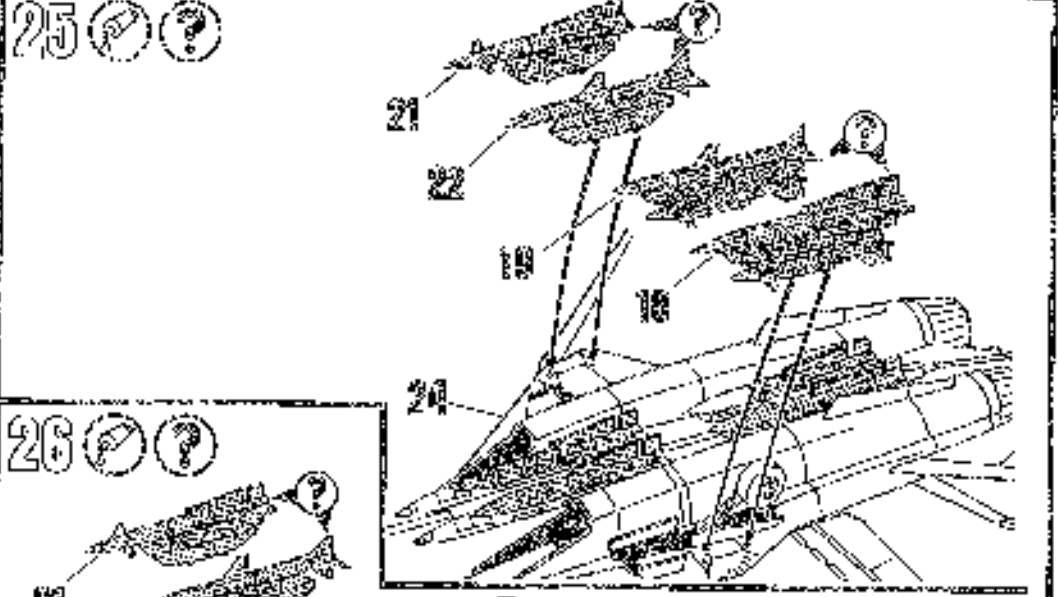
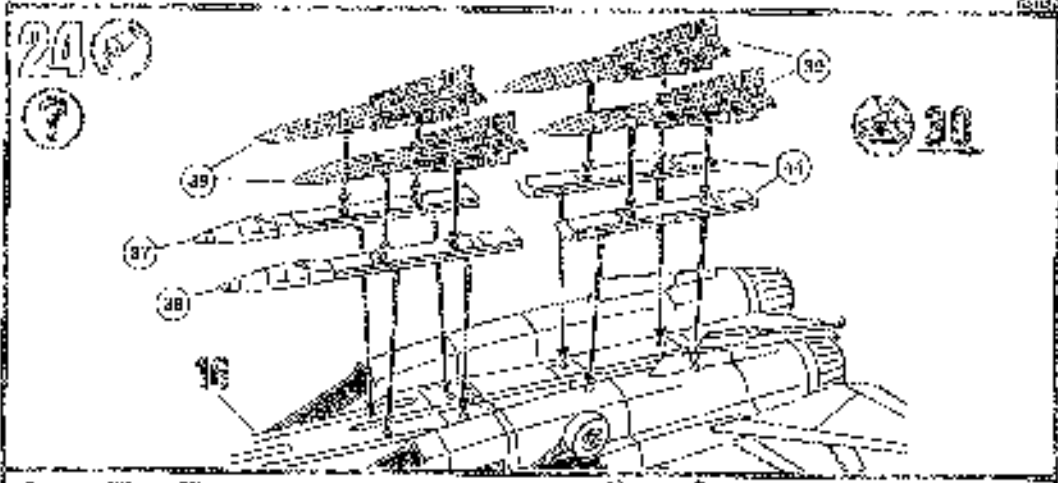

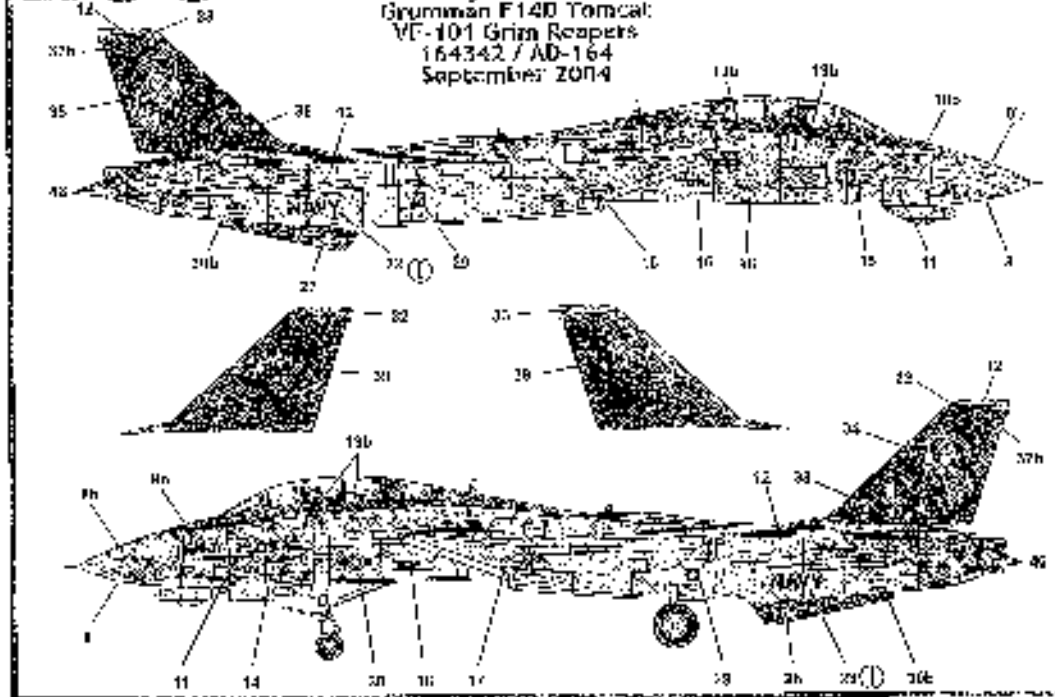
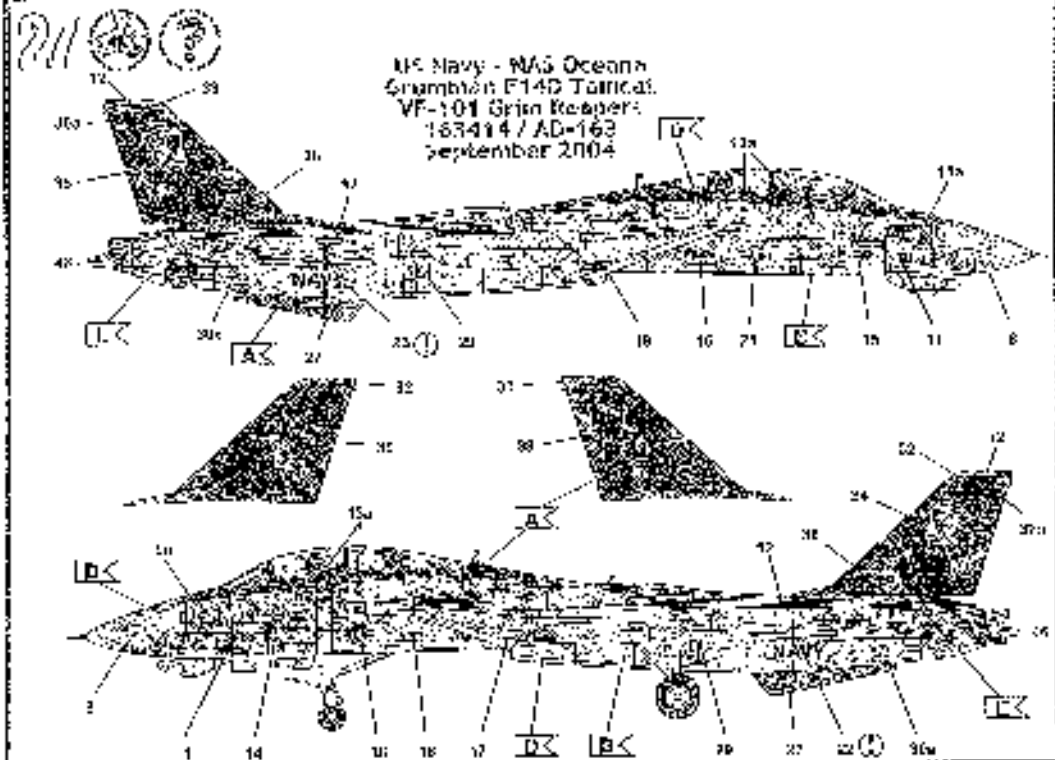
US Navy - NAS Oceana  
 Grumman F-14 Tomcat  
 VF-101 Grim Reapers  
 163414 / AD-163  
 &  
 164342 / AD-163

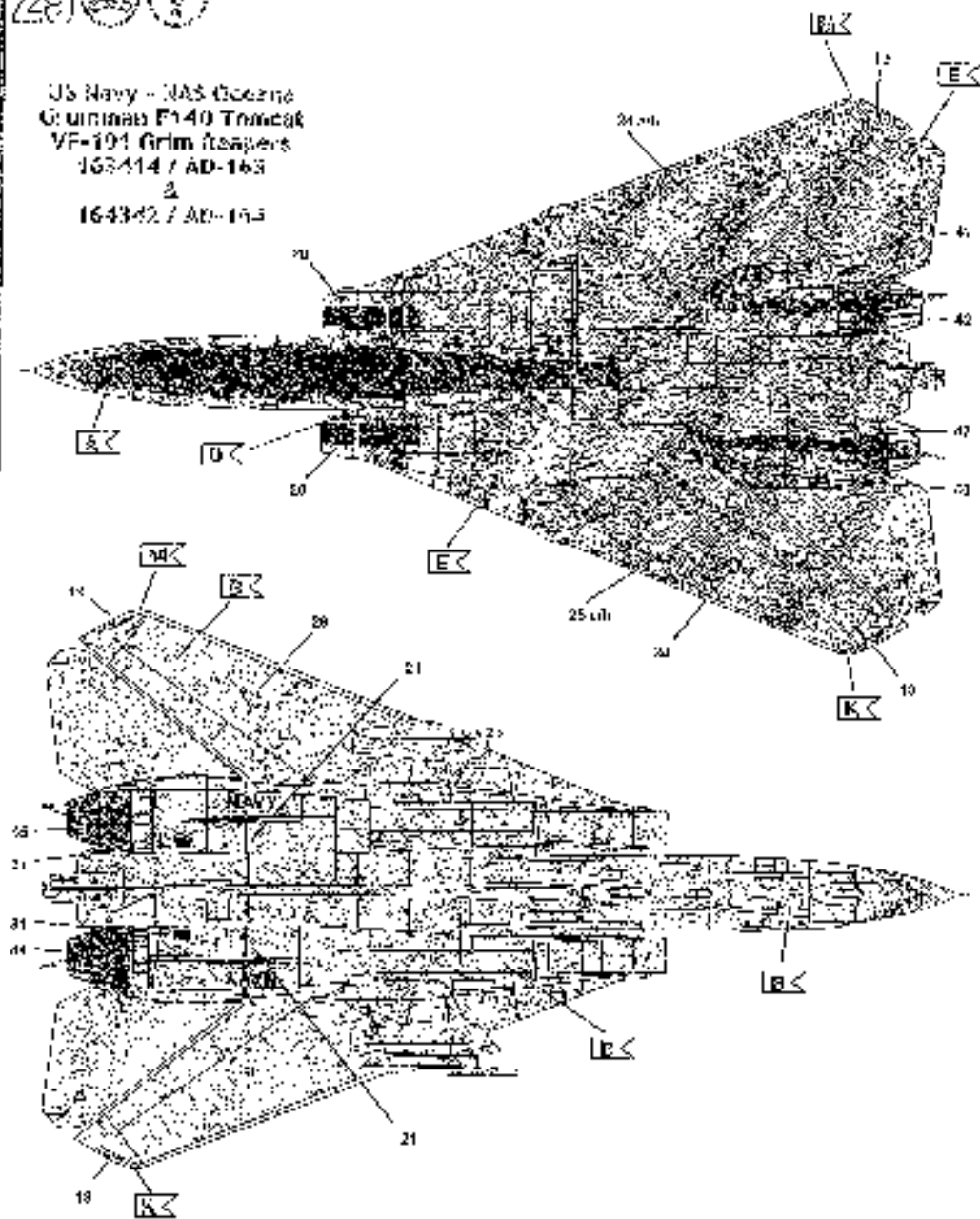



US Navy - Persian Gulf  
Grumman F14D Tomcat  
VF-212 Black Lions  
167155 / A1-204  
February 2006

