



Dassault RAFALE M ^{bomb & rack}

04517-0389

© 2012 BY REVELL GmbH & Co. KG. A subsidiary of Hobbico, Inc.

PRINTED IN GERMANY



Dassault RAFALE M ^{bomb & rack}

Im Jahr 1978 startete bei Dassault das ACX-Programm (eXperimental Combat Aircraft) für die Entwicklung eines höchst effektiven Mehr-Zweck-Kampfflugzeugs, versehen mit neuester Technologie und inklusive der Fähigkeit, auf einem Flugzeugträger starten und landen zu können. Es sollte alle damals eingesetzten Kampfflugzeuge ersetzen. Am 4. Juli 1986 startete der Rafale A Prototyp zu seinem Jungfernflug vom Test Zentrum der Airbase 125 Istres. Zu diesem Zeitpunkt war der Prototyp mit F404 Triebwerken ausgestattet, die auch in die F/A-18 installiert waren. Die Test- und Erprobungsflüge für die Rafale Prototypen begannen im Januar 1988. Diese Maschinen bestanden aus einer Rafale C, einer Rafale B (Zweisitzer) und zwei modifizierten Rafale M für den Flugzeugträger Einsatz, die erstmalig am 12. Dezember 1991 flogen. Diese Versionen unterscheiden sich deutlich von der anfänglichen Rafale A-Version. So sind Kohlenfaserverbundstoffe für den Zellaufbau verwendet worden, die Rafale wurde kompakter und hat ein geringeres Gewicht. Die Rafale ist dann auch mit den leistungsstärkeren Snecma M88 Triebwerken ausgerüstet worden. Auch die Flugzeugzelle ist optimiert worden um die Radarsignatur zu reduzieren. Die Rafale wurde in drei Stufen (Version F1, F2 und F3) entwickelt. Die zuerst eingesetzte Rafale ist die Rafale M F1 bei der Flottille 12F in 2001. Es handelt sich um ein reines Kampfflugzeug, ausgerüstet mit Luft-Luft-Lenk Waffen und Bordkanonen. Die F2-Version (Jagdbomber) wurde im Jahre 2005 an die französische Luftwaffe und die Marine ausgeliefert. Die Auslieferung der Mehrzweck-Version F3 begann im Jahre 2009 nach umfangreichen Änderungen. Die Rafale kann viele Missionsprofile erfüllen, einschließlich der Luftüberlegenheitsrolle, taktische Unterstützung, den Einsatz mit lasergelenkten Bomben, Marschflugkörperabwurf, Angriff auf Seeziele, Aufklärung und auch Luft-Luft-Betankung. Diese Eigenschaften machen die Rafale zu einem ernsthaften Konkurrenten für die JAS-39 Gripen, den Eurofighter Typhoon und die F/A-18E/F Super Hornet. Die F4-Version ist derzeit noch in der Projektphase, sie wird mehr Stealth-Eigenschaften besitzen, mit einem stärkeren Aktiv-Radar ausgerüstet sein und in der Lage sein, Langstrecken Luft-Luft-Lenk Waffen abzuwerfen. Damit könnte sie ein ernsthafter Konkurrent für die F-22 und F-35 werden. Im Juni 2010 feierten die Französischen Marine Flieger ihr 100 Jahre-Jubiläum. Die Rafale M spielte dabei eine wichtige Rolle. Die Flottille 11F, die bislang die modernisierte Super-Étendard (SEM) benutzte, rüstete im Februar 2012 auf die Rafale M um. Die Flottille 17F, die die SEM immer noch fliegt wird zukünftig auch auf Rafale M umstellen. Beide Flotten sind auf der Marine Luftwaffen Basis in Landivisiau, Bretagne, stationiert. Die Flugzeuge werden regelmäßig an Bord des Flugzeugträgers Charles-De-Gaulle eingesetzt und um stationiert. Sie wurden bereits bei vielen großen Konflikten während den letzten Jahren eingesetzt, insbesondere in Afghanistan während der Operation Heracles, und in Libyen während der Operation Harmattan.

Rafale M Technische Daten:

Spannweite:	10,90m	Länge:	15,30m
Höhe:	5,34m	Leergewicht:	9670 kg
Gewicht max:	24500 kg	Maximale Waffenzuladung :	8000 kg
Treibstoff max:	4800 kg (intern) plus 6800 kg (extern)		
Triebwerke:	2x M88-2 (2x 48,7kN – 72,9kN mit Nachbrenner)		
Geschwindigkeit max:	2200 km/h (Mach 1,8)		
Dienstgipfelhöhe:	16800m (55000ft)		
Steigleistung max:	18000m/min		
Reichweite:	1090 km (Bodennähe) – 1850 km (in großer Höhe)		
Bord Bewaffnung:	1 x 30 mm Giat DEFA 791B Kanone		
Externe Bewaffnung :	Mica-IR Infra-Red Luft-Luft-Lenk Waffe Mica-EM Elektromagnetische Luft-Luft-Lenk Waffe Mk82 / Mk83 / Mk84 Bomben Laser/GPS GBU-12 / GBU-24 / AASM Lenkbomben Apache / SCALP-EG / ASMP-A (nuklear) Marschflugkörper Exocet AM39 B2 Anti-Schiffs-Lenk Waffe Reco-NG Aufklärungspod Douglas Luft-Luft Betankungspod		

Dassault RAFALE M ^{bomb & rack}

In 1978 Dassault started the ACX program (eXperimental Combat Aircraft) for a highly successful multi-role combat aircraft incorporating the latest technology including the ability to operate from an aircraft carrier. It would replace all combat aircraft currently in service. On 4th July 1986 the Rafale A demonstrator prototype took off on its maiden flight from the Flight Test Centre at Airbase 125 Istres. At this time it was fitted with the American manufactured F404 engines which also powered the F/A-18. Air-testing and proving for the Rafale prototypes commenced in January 1988. This consisted of one Rafale C, one Rafale B (two-seater) and two Rafale M modified for carrier operation which flew for the first time on 12th December 1991. This version differs significantly from the Rafale A demonstrator. Composite materials are used in its construction, it is smaller in size and has a lower weight. It is fitted with the more powerful Snecma M88 engines. The design is also optimized to reduce the radar signature. The Rafale was developed in three stages (versions F1, F2 and F3). The first Rafale to enter service was the Rafale M version F1 with Flotilla 12F in the year 2001. It is a pure fighter equipped only with air-to-air missiles and cannon. The F2 version (fighter-bomber) was delivered to the Air Force and the Navy in 2005. After on-going modification delivery of the multi-role F3 version commenced in 2009. It can undertake many mission profiles including Air Superiority, Tactical Support, Guided or non-guided Bombing, Cruise Missiles launch, Anti-Shipping Attack, Reconnaissance and also Air to Air Refuelling using the Douglas refuelling pod. These attributes make the Rafale a serious competitor to the Saab JAS-39 Gripen, Eurofighter and F/A-18E/F Super Hornet. The F4 version is currently still in the project stage, it will have more stealth, be equipped with a more powerful active radar and be capable of launching long range Air-to-Air missiles. It could be a competitor against American F-22 and F-35. French Naval Aviation celebrated its 100th anniversary in June 2010 and the Rafale M played an important role in the festivities. The Rafale M has been in service with the Flotilla 12F since 2001. Flotilla 11F which was operating the Modernized Super-Étendard (SEM) has been converting to Rafale M since February 2012. In the future Flotilla 17F which is still flying the SEM will also convert to the Rafale M. Both these Flottillas are stationed at the Landivisiau Naval Air Base in Brittany. Aircraft are regularly embarked on the aircraft carrier R91 Charles-De-Gaulle and have already taken part in major conflicts over the last few years, in particular over Afghanistan on Operation Heracles, and in Libya during Operation Harmattan.

Rafale M Technical Data:

Wingspan:	10,90m
Length:	15,30m
Height:	5,34m
Empty Weight:	9670 kg
Maximum Weight:	24500 kg
Maximum Fuel Capacity:	4800 kg (internal) + 6800 kg (external)
Maximum Armament Load:	8000 kg
Engines:	2x M88-2 (2x 48,7kN – 72,9kN with after-burner)
Maximum Speed:	2200 km/h (Mach 1,8)
Service Ceiling:	16800m (55000ft)
Maximum Rate of Climb:	18000m/min
Range:	1090 km (Low level) – 1850 km (High Altitude)
Internal Armament:	1 x 30 mm Giat DEFA 791B Cannon
External Weapons :	Mica-IR Infra-Red (Air-to-Air) Missile Mica-EM Electro-Magnetic (Air-to-Air) Missile Mk82 / Mk83 / Mk84 Unguided Bombs Laser/GPS Guided GBU-12 / GBU-24 / AASM Bombs Apache / SCALP-EG / ASMP-A (nuclear) Cruise Missiles Exocet AM39 B2 Anti-Ship Missile Reco-NG Reconnaissance Pod Douglas Air to Air Refuelling Pod

Alle Rechte vorbehalten. Nachdruck, Vervielfältigung und Verbreitung, auch auszugsweise, ist ohne schriftliche Genehmigung der Revell GmbH & Co. KG. Das Markenrecht ist vorbehalten. Alle Rechte vorbehalten. Nachdruck, Vervielfältigung und Verbreitung, auch auszugsweise, ist ohne schriftliche Genehmigung der Revell GmbH & Co. KG. Das Markenrecht ist vorbehalten. Alle Rechte vorbehalten. Nachdruck, Vervielfältigung und Verbreitung, auch auszugsweise, ist ohne schriftliche Genehmigung der Revell GmbH & Co. KG. Das Markenrecht ist vorbehalten.

Benötigte Farben / Used Colors

Benötigte Farben Required colours	Peintures nécessaires Benodigde kleuren	Pinturas necesarias Tintas necessárias	Colori necessari Använda färger	Tarvittavat värit Du trenger følgende farger	Nødvendige farger Необходимые краски	Potrzebne kolory Απαιτούμενα χρώματα	Gerekli renkler Potřebné barvy	Szükséges színek. Potrebne barve	
A	B	C	D	E	F	G	H		
anthrazit, matt 9 anthracite grey, matt anthracite, mat antraciet, mat antracita, mate antracite, fosco antracite, opaco antracit, matt antrasiti, himmeä koksgrå, mat antrasitt, matt антрацит, матовый antracyt, matowy ανθρακί, ματ antrasit, mat antrasit, matná antracit, matt tamno siva, mat	aluminium, metallic 99 aluminium, metallic aluminium, métallique aluminium, metallic aluminio, metalizado aluminio, métallico aluminio, metallico aluminium, metallic aluminium, metallic alumiini, metallikiito aluminium, metallak aluminium, metallic алюминиевый, металллик aluminium, metalliczny αλουμινίου, μεταλλικό alüminyum, metallik hinikovná, metaliza aluminium, métal aluminium, metallik	schwarz, seidenmatt 302 black, silky-matt noir, satiné mat zwart, zijdemat negro, mate seda preto, fosco sedoso nero, opaco seta svart, sidenmatt musta, silkinhimmeä sort, silkematt sort, silkematt чёрный, шелковисто-матовый czarny, jedwabisto-matowy μαύρο, μεταξωτό ματ siyah, ipek mat černá, hedvábně matná fekete, selyemmatt črna, svila mat	eisen, metallic 91 steel, metallic coloris fer, métallique ijzerkleurig, metallic ferroso, metalizado ferro, metallico ferro, metallico järnfärg, metallic teräksenväriäinen, metallikiito jern, metallak jern, metallic стальной, металллик železo, metalliczny σιδηρού, μεταλλικό demir, metallik železná, metaliza vas, metáll železna, metallik	teerswarz, matt 6 tar black, matt noir tartre, mat teerzwart, mat negro alquitran, mate alcatrão, fosco nero catrame, opaco asfaltsvart, matt tervanmusta, himmeä tjæresort, matt tjæresort, matt смолисто-чёрный, матовый czarny-smoła, matowy μαύρο πίσσας, ματ siyah, ipek mat dehtové černá, matná kátrányfekete, matt ter črna, mat	mausgrau, matt 47 mouse grey, matt gris souris, mat muisgrijs, mat gris ratón, mate cinzento pardo, fosco grigio topo, opaco musgrå, mat hiirenharmaa, himmeä musegrå, mat musegrå, matt мышинно-серый, матовый myszaty, matowy γκρι ποντικίου, ματ fare gris, mat mysi šedá, matná egérszürke, matt mišje siva, mat	laubgrün, seidenmatt 364 leaf green, silky-matt vert feuille, satiné mat bladgroen, zijdemat verde follaje, mate seda verde gaio, fosco sedoso verde foglia, opaco seta lövgroen, sidenmatt lehdenvihreä, silkinhimmeä lvgrön, silkematt lvgrön, silkematt лиственно-зеленый, шелк.-матовый zielony liściasty, jedwabisto-matowy πράσινο φυλλωμάτων, μεταξ, ματ yaprak yeşilli, ipek mat zelená jako listí, hedvábně matná lombzöld, selyemmatt list zelena, svila mat	Blau, klar 752 Blue, clear Bleu, transparent Blauw, transparent Azul, transparente Azul, claro Blu, trasparente Blå, klar Sininen, kirkas Blå, klar Blå, klar Синий, прозрачный Młve, kaibaró Mavi, açık Kék, átlátszó Modrá, jasná Modra, prozorna		
70 %	I	30 %	95 %	J	5 %	80 %	M	20 %	N
eisen, metallic 91 + steel, metallic coloris fer, métallique ijzerkleurig, metallic ferroso, metalizado ferro, metallico ferro, metallico järnfärg, metallic teräksenväriäinen, metallikiito jern, metallak jern, metallic стальной, металллик železo, metalliczny σιδηρού, μεταλλικό demir, metallik železná, metaliza vas, metáll železna, metallik	anthrazit, matt 9 anthracite grey, matt anthracite, mat antraciet, mat antracita, mate antracite, fosco antracite, opaco antracit, matt antrasiti, himmeä koksgrå, mat antrasitt, matt антрацит, матовый antracyt, matowy ανθρακί, ματ antrasit, mat antrasit, matná antracit, matt tamno siva, mat	farblos, glänzend 1 + clear, gloss incoloro, brillante kleurloos, glansend incoloro, brillante incolor, brillante trasparente, lucente färglös, blank värifön, kiiltävä farvelos, skinnende klar, blank бесцветный, блестящий bezbawny, błyszczący άχρωμο, υαλοστερό renkisz, parlak bezbarvená, lesklá szintelen, fényes brezbarvna, bleskajoča	seeigrün, matt 48 sea green, matt vert d'eau, mat zeegroen, mat verde mar, mate verde-mar, fosco verde lago, opaco havsgroen, matt merenvihreä, himmeä havgrön, mat sjögrön, matt зеленый морской, матовый zieloné morska, matowy πράσινο λίμνης, ματ göl yeşilli, mat mořská zelená, matná tengerzöld, matt morsko zelena, mat	rot, klar 731 red, clear rouge, clair rood, helder rojo, claro vermelho, claro rosso, chiaro röd, klar punainen, kirkas röd красный czewień κόκκινο, διαυγές kirmizi, şeffaf červená, čirá piros, áttetsző rdéa, jasna	hellgrau, seidenmatt 371 light grey, silky-matt gris clair, satiné mat lichtgrijs, zijdemat gris claro, mate seda cinzento claro, fosco sedoso grigio chiaro, opaco seta ljusgrå, sidenmatt vaaleanharmaa, silkinhimmeä lysegrå, silkematt lysegrå, silkematt светло-серый, шелковисто-матовый jasnoszary, jedwabisto-matowy ανοιχτό γκρι, μεταξωτό ματ açık gri, ipek mat světlešedá, hedvábně matná világosszürke, selyemmatt sveto siva, svila mat	grau, seidenmatt 374 + grey, silky-matt gris, satiné mat grijs, zijdemat gris, mate seda cinzento, fosco sedoso grigio, opaco seta grå, sidenmatt harmaa, silkinhimmeä grå, silkematt grå, silkematt серый, шелковисто-матовый szary, jedwabisto-matowy γκρι, μεταξωτό ματ gri, ipek mat šedá, hedvábně matná szürke, selyemmatt siva, svila mat	blaugrau, matt 79 greyish blue, matt gris-bleu, mat blauwgrijs, mat gris azulado, mate cinzento azulado, fosco grigio blu, opaco blågrå, matt siniharmaa, himmeä blågrå, matt blågrå, matt сине-серый, матовый siwy, matowy γκριζομπλέ, ματ mavi gri, mat modróšedá, matná kékesszürke, matt plavo siva, mat	dunkelgrau, seidenmatt 378 dark grey, silky-matt gris foncé, satiné mat donkergrijs, zijdemat gris oscuro, mate seda cinzento escuro, fosco sedoso grigio scuro, opaco seta mörkgrå, sidenmatt harmaa, silkinhimmeä markgrå, silkematt markgrå, silkematt серый, шелковисто-матовый szary, jedwabisto-matowy γκρι, μεταξωτό ματ gri, ipek mat šedá, hedvábně matná szürke, selyemmatt siva, svila mat	
O	P	90 %	Q	10 %	R	S	T	U	
weiß, seidenmatt 301 white, silky-matt blanc, satiné mat wit, zijdemat blanco, mate seda branco, fosco sedoso bianco, opaco seta vit, sidenmatt valkoinen, silkinhimmeä hvid, silkematt hvit, silkematt белый, шелковисто-матовый biały, jedwabisto-matowy λευκό, μεταξωτό ματ beyaz, ipek mat bilá, hedvábně matná fehér, selyemmatt beia, svila mat	silber, metallic 90 silver, metallic argent, métallique zilver, metallic plata, metalizado prata, metallico argento, metallico silver, metallic hopea, metallikiito solv, metallak solv, metallic серебристый, металллик srebro, metalliczny ασμύ, μεταλλικό gümüş, metallik stříbrná, metaliza ezüst, metáll srebrna, metallik	lichtblau, glänzend 50 + light blue, gloss bleu clair, brillant lichtblauw, glansend azul celeste, brillante azul celeste, brillante blu celeste, lucente ljusblå, blank vaaleansininen, kiiltävä lysende blå, skinnende lyseblå, blank голубой, блестящий jasnoniebieski, błyszczący μπλε φωτός, υαλοστερό ışık mavisi, parlak světlemodrá, lesklá világító kék, fényes svetlo plava, bleskajoča	blau, matt 56 blue, matt bleu, mat blauw, mat azul, mate azul, fosco blu, opaco blå, matt sininen, himmeä blå, mat blå, matt синий, матовый niebieski, matowy μπλε, ματ mavi, mat modrá, matná kék, matt plava, mat	rost, matt 83 rust, matt rouille, mat roest, mat orin, mate ferrugem, fosco color ruggine, opaco rost, matt ruoste, himmeä rust, mat rust, matt ржавчина, матовый rózawy, matowy χρώμα σκουριάς, ματ pas rengi, mat rezavá, matná rozsdá, matt řjava, mat	olivgrün, seidenmatt 361 olive green, silky-matt vert olive, satiné mat oijfiroen, zijdemat verde aceituna, mate seda verde azeitona, fosco sedoso verde oliva, opaco seta olivgrön, sidenmatt olivivihreä, silkinhimmeä olivgrön, silkematt olivengrön, silkematt зеленый оливковый, шелк.-матовый oliwkowy, jedwabisto-matowy πράσινο ελιάς, μεταξωτό ματ zeytin yeşilli, ipek mat olivové zelená, hedvábně matná olivzöld, selyemmatt oliva zelena, svila mat	dunkelgrün, seidenmatt 363 dark green, silky-matt vert foncé, satiné mat donkergroen, zijdemat verde oscuro, mate seda verde escuro, fosco sedoso verde scuro, opaco seta mörkgrön, sidenmatt tummanvihreä, silkinhimmeä markgrön, silkematt markgrön, silkematt темно-зеленый, шелк.-матовый ciemnozielony, jedwabisto-matowy σκοуро πράσινο, μεταξωτό ματ koyu yeşil, ipek mat tmavozelená, hedvábně matná sötétzöld, selyemmatt temno zelena, svila mat	beige, seidenmatt 314 beige, silky-matt beige, satiné mat donkergroen, zijdemat beige, mate seda beige, fosco sedoso verde oliva, opaco seta beige, sidenmatt beige, silkinhimmeä beige, silkematt beige, silkematt бежевый, шелковисто-матовый beżowy, jedwabisto-matowy μπέζ, μεταξωτό ματ bej, ipek mat béžová, hedvábně matná bézs, selyemmatt sionova kost, svila mat		
V									
gold, metallic 94 gold, metallic or, métallique goud, metallic oro, metalizado ouro, metallico oro, metallico guld, metallic kulta, metallikiito guld, metallak guld, metallic золотой, металллик złoto, metalliczny χρυσόφι, μεταλλικό altın, metallik zlatá, metaliza arany, metáll zlatna, metallik									

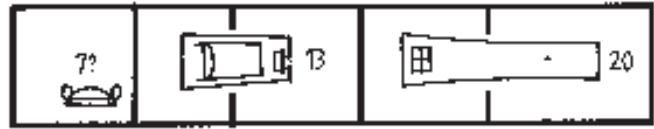
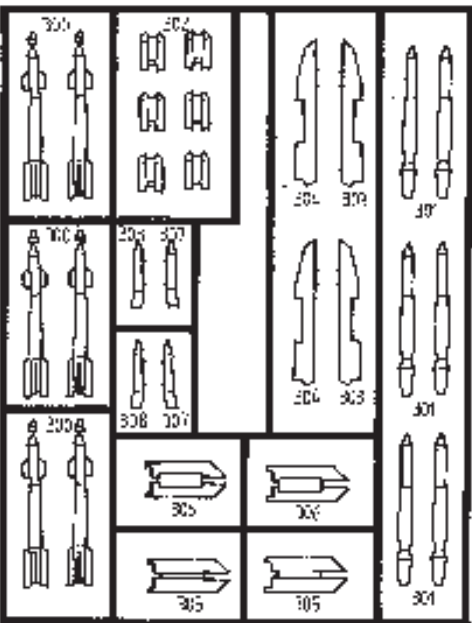
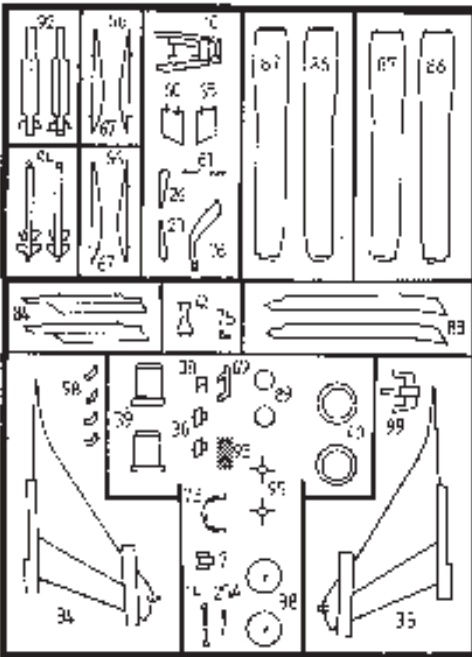
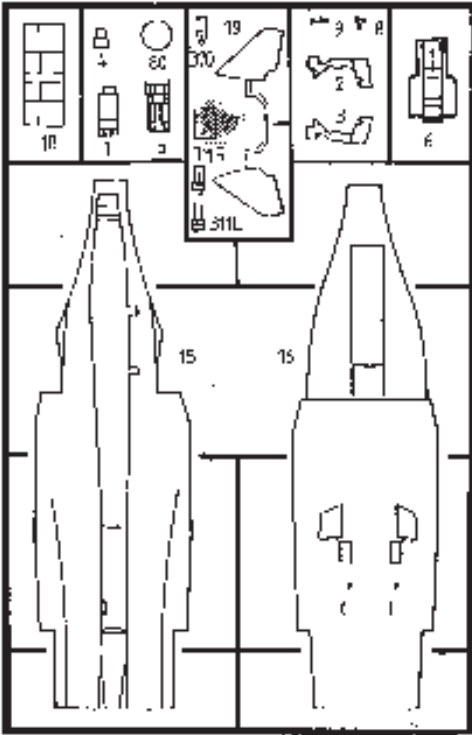

 Nicht benötigte Teile
 Parts not used
 Pièces non utilisées
 Niet benodigde onderdelen
 Piezas no necesarias
 Peças não utilizadas
 Parti non usate
 Inte anvánda delar
 Tarpeettomat osat
 Ikke nødvendige dele
 Deler som ikke er nødvendige
 Неиспользованные детали
 Elementy niepotrzebne
 μη χρειαζόμενα εξαρτήματα
 Gereksiz parçalar
 Nepotřebné díly
 fel nem használt alkatrészek
 Nepotrební deli

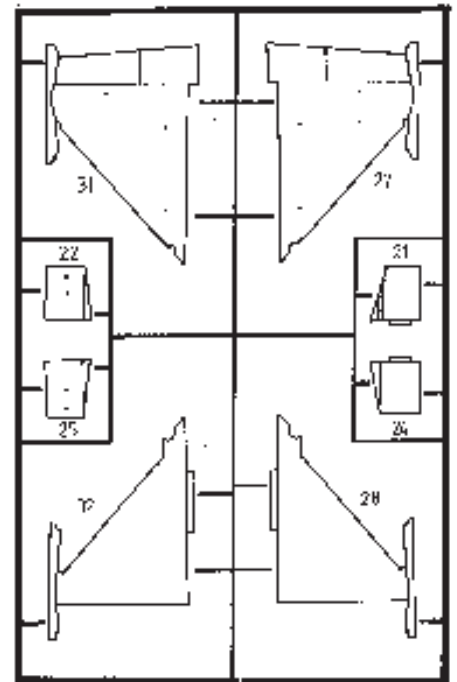
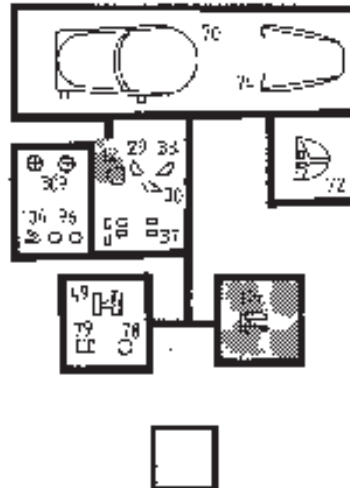
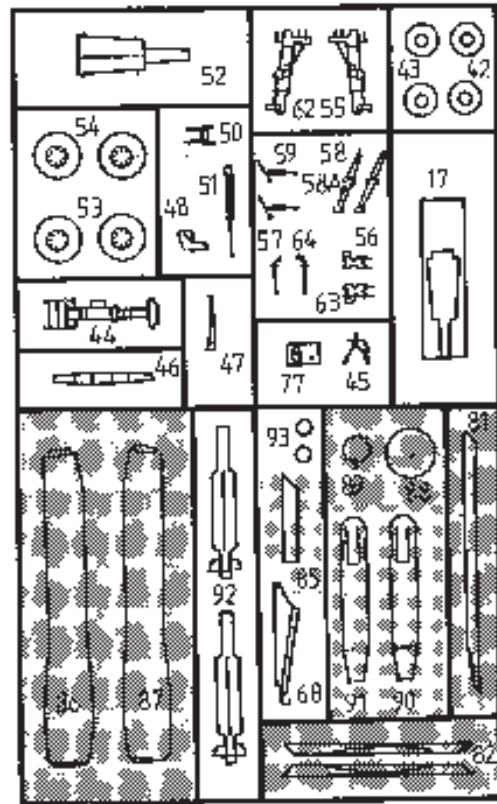

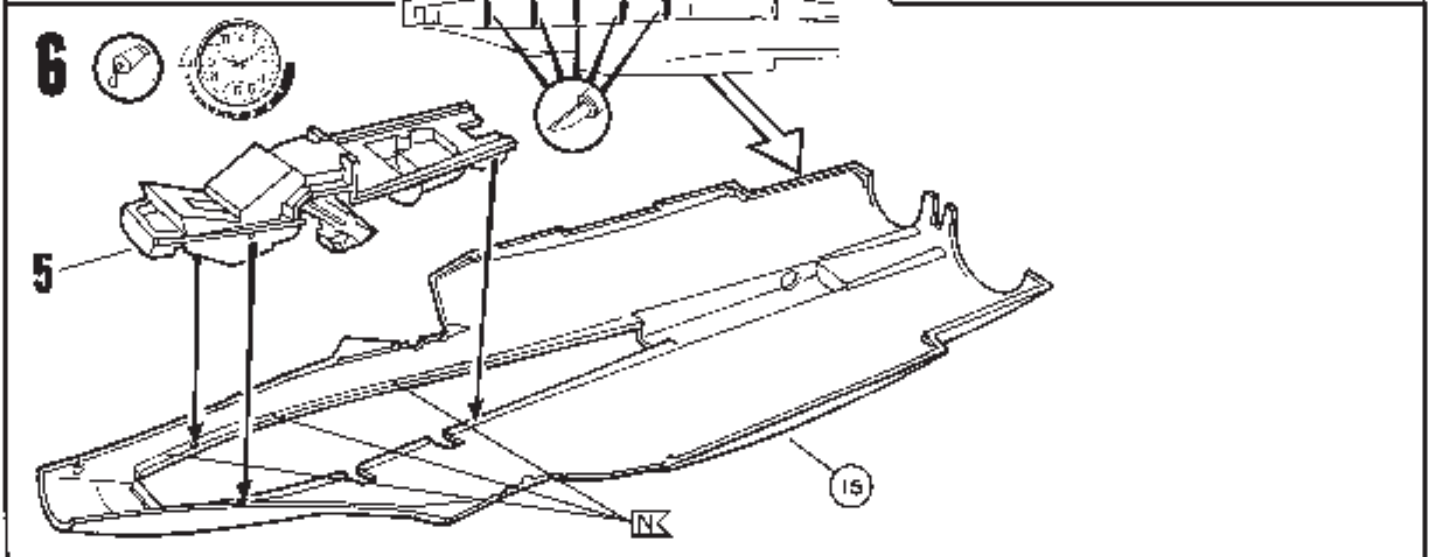
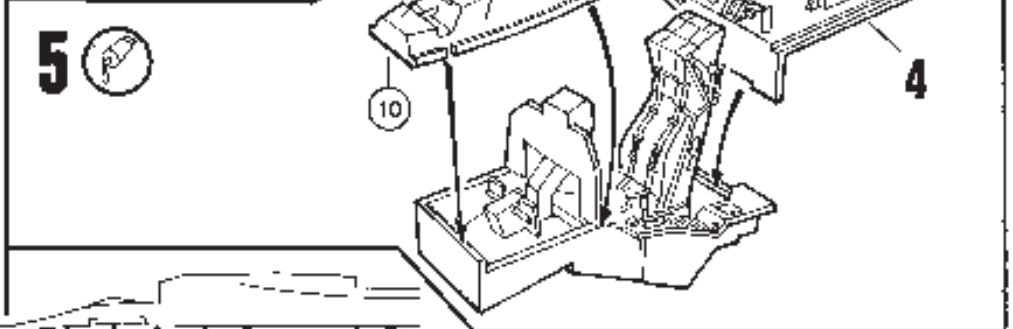
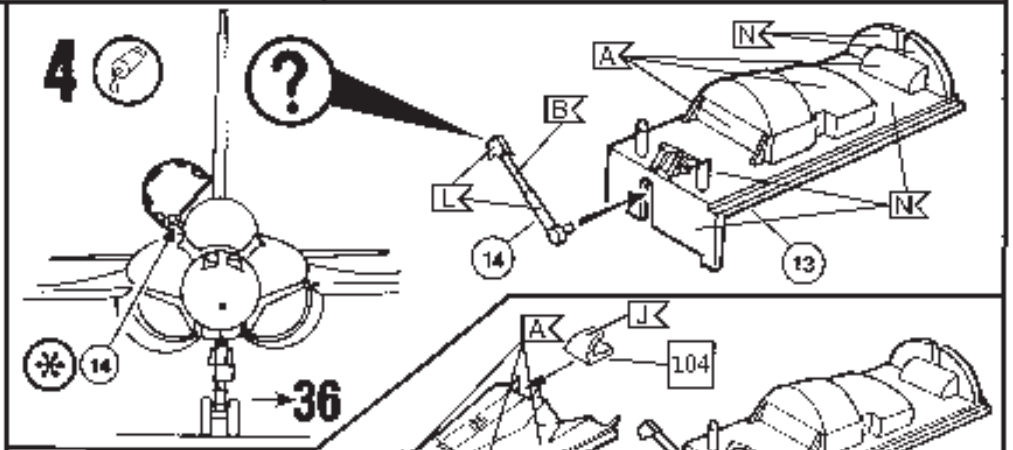
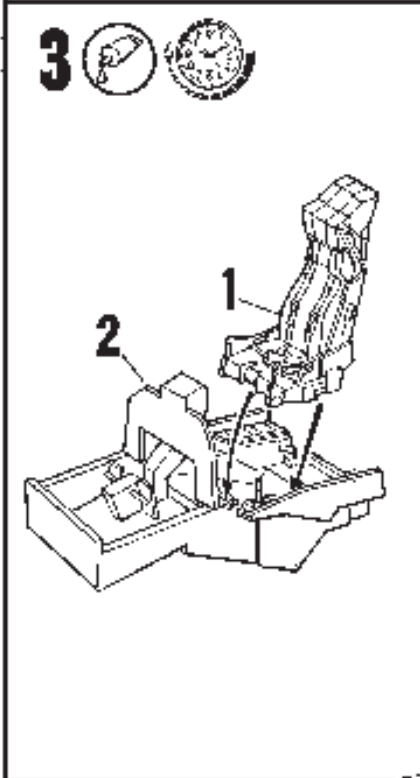
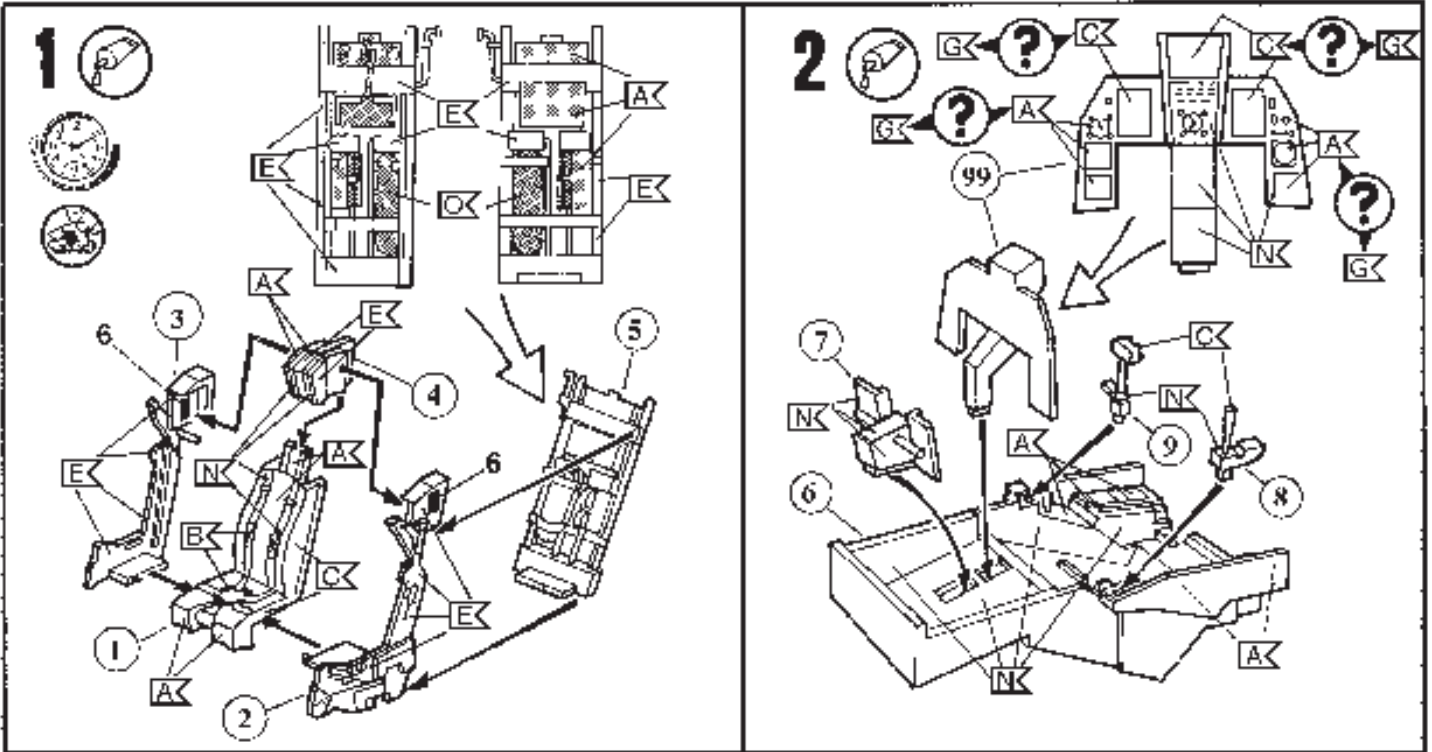

7

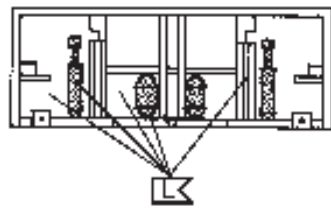

18

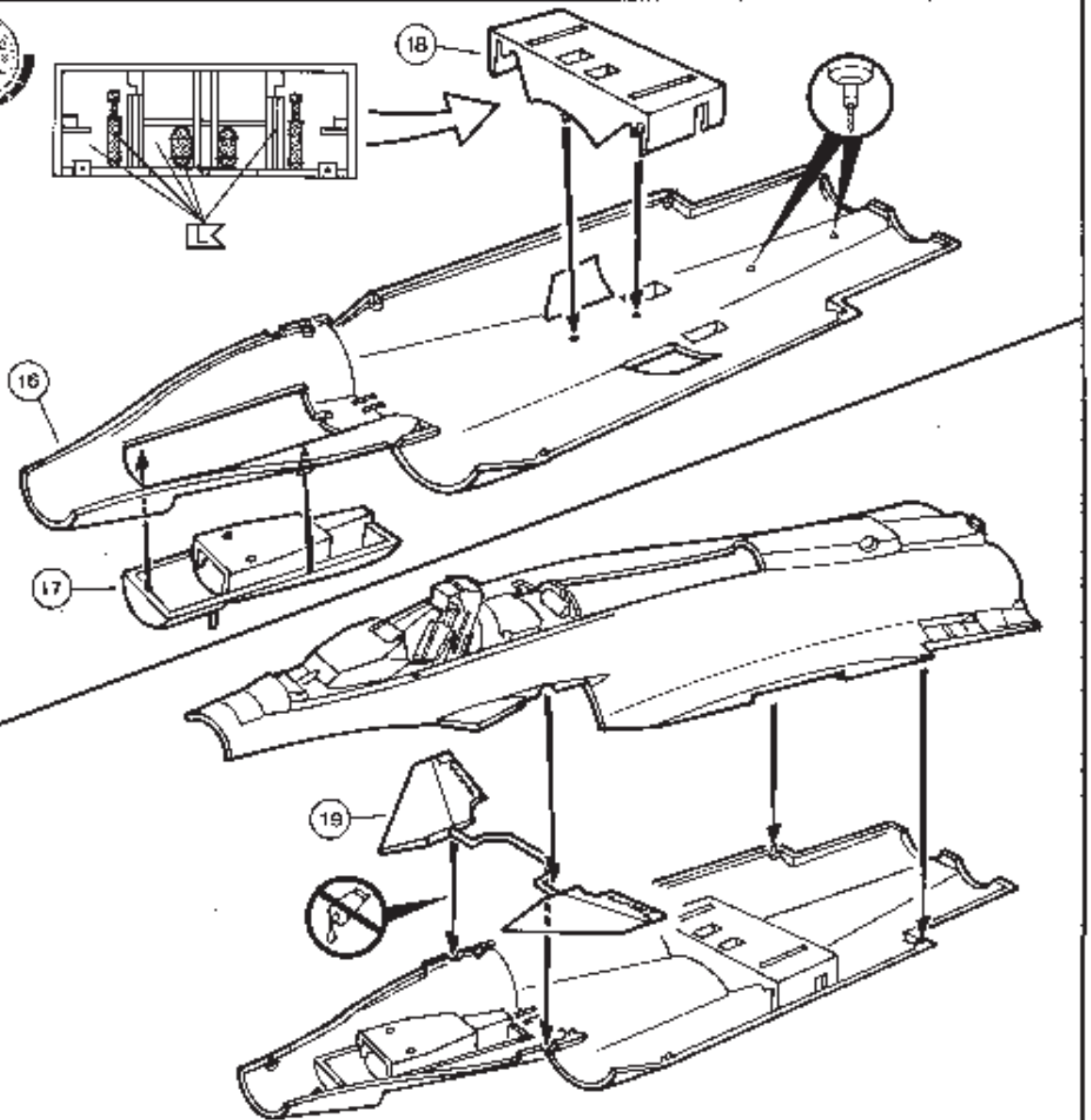

8



19

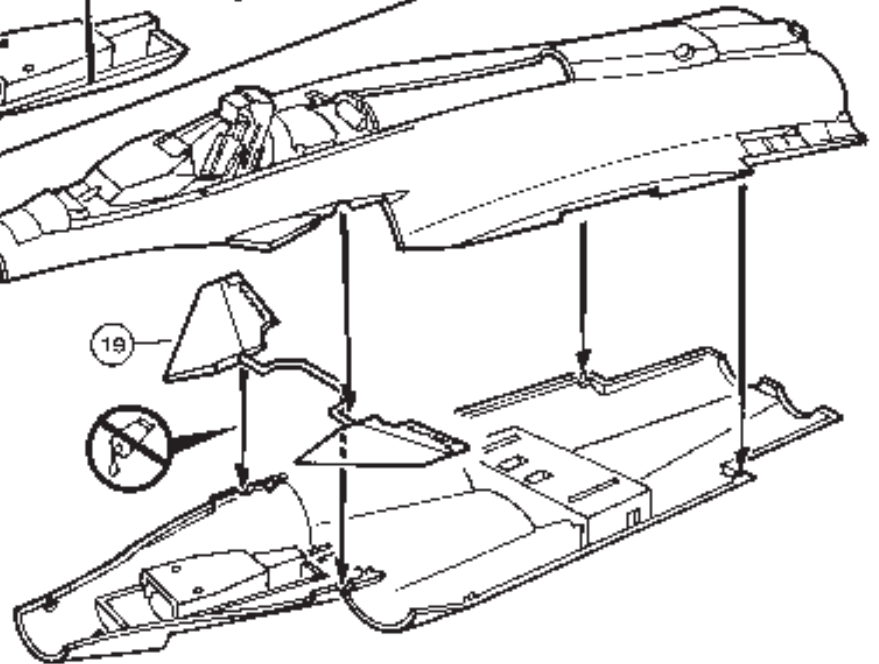

9

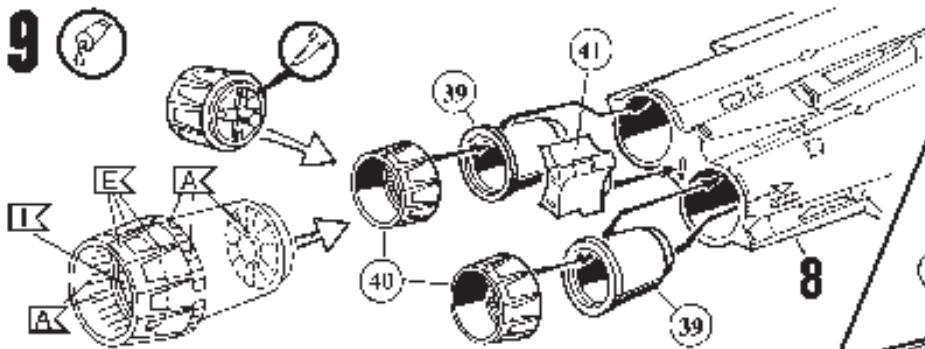

10

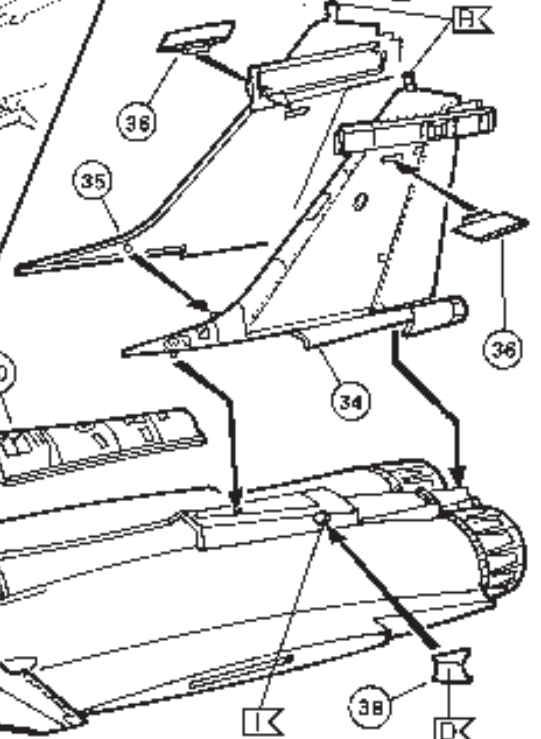

11

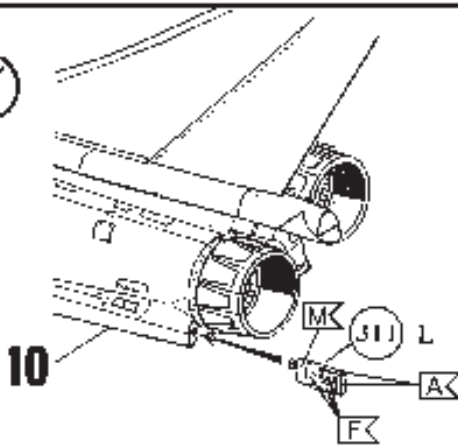

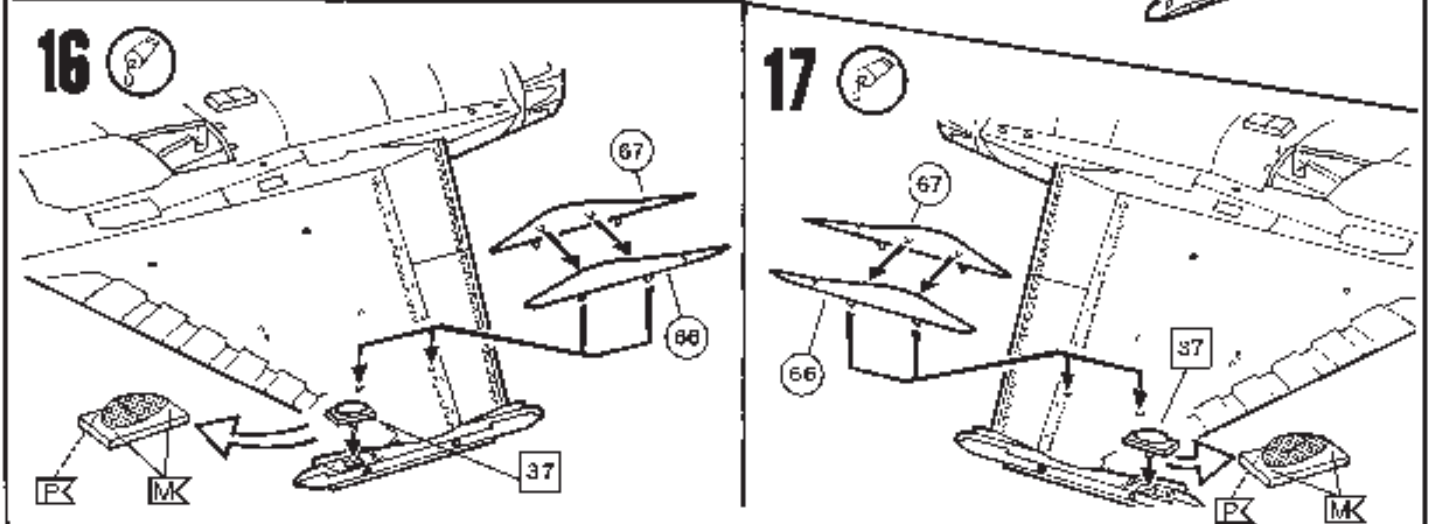
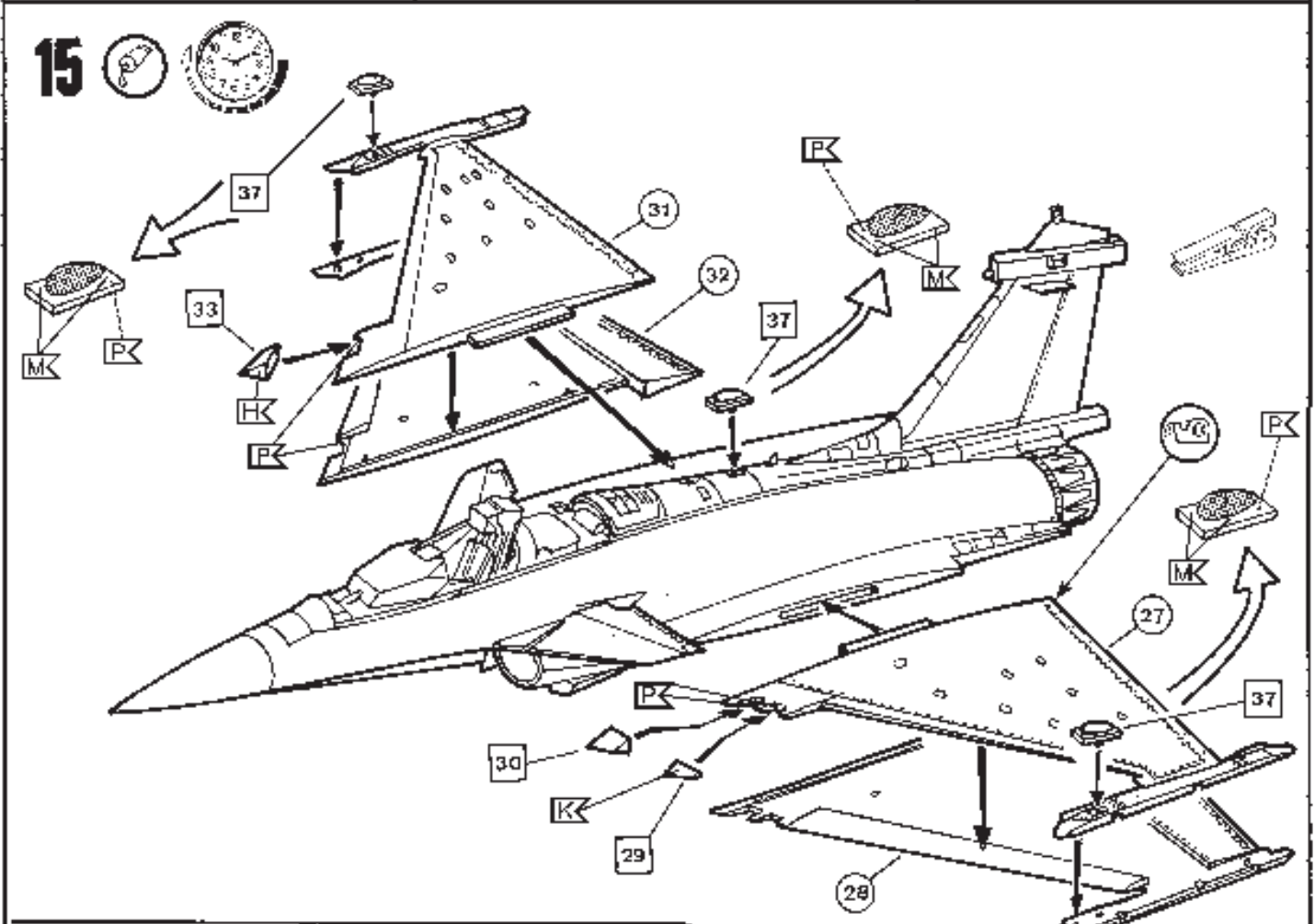
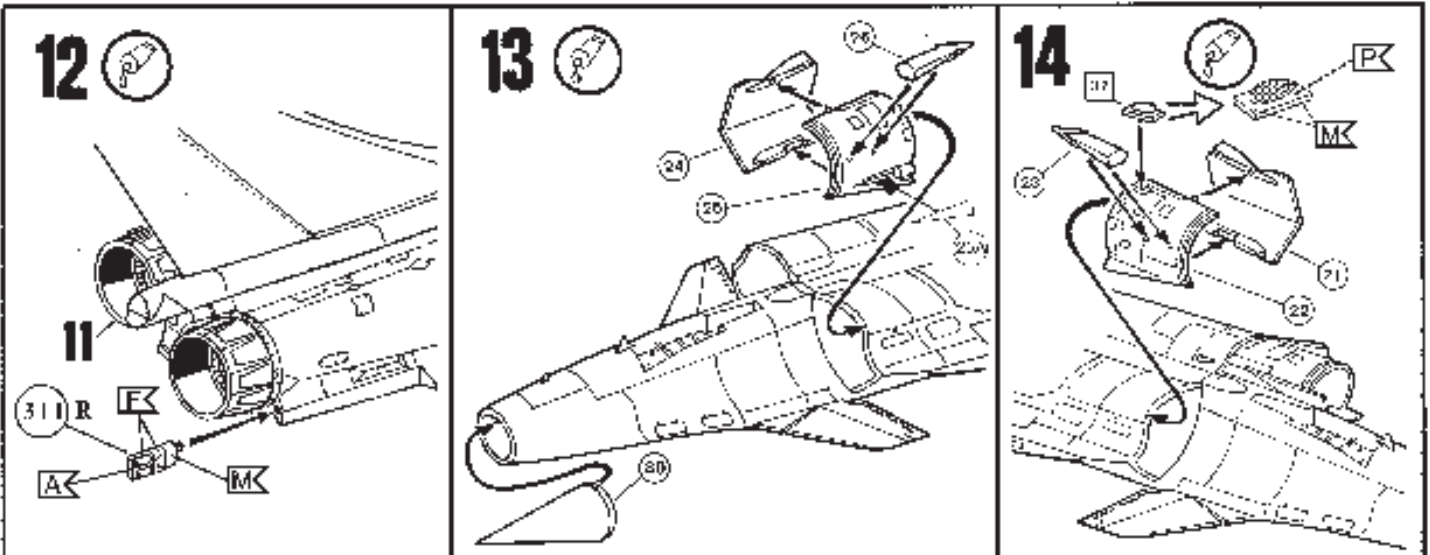

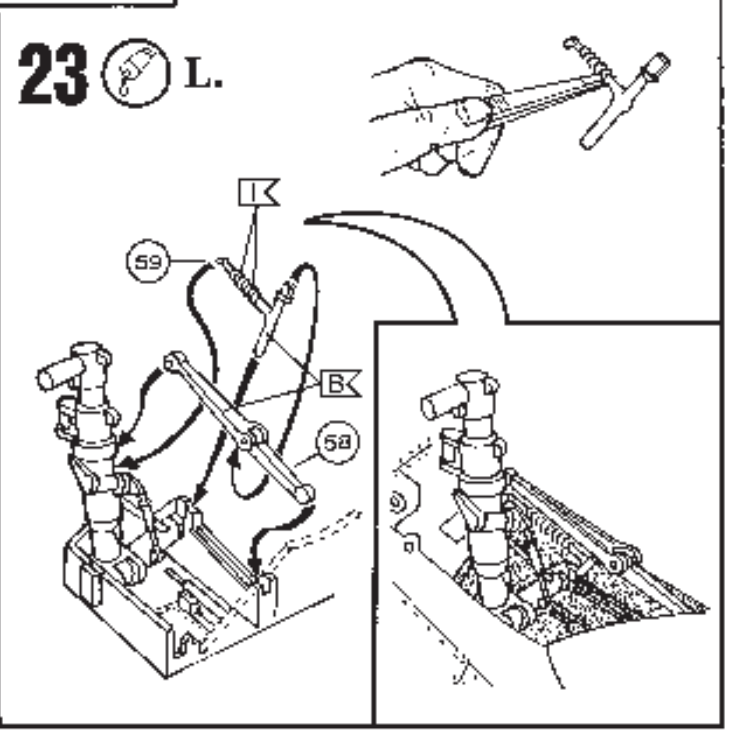
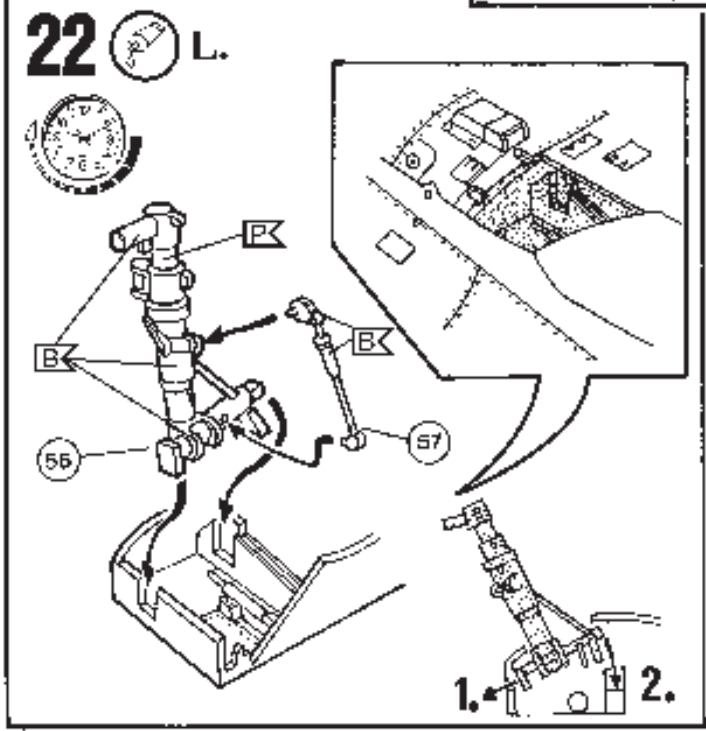
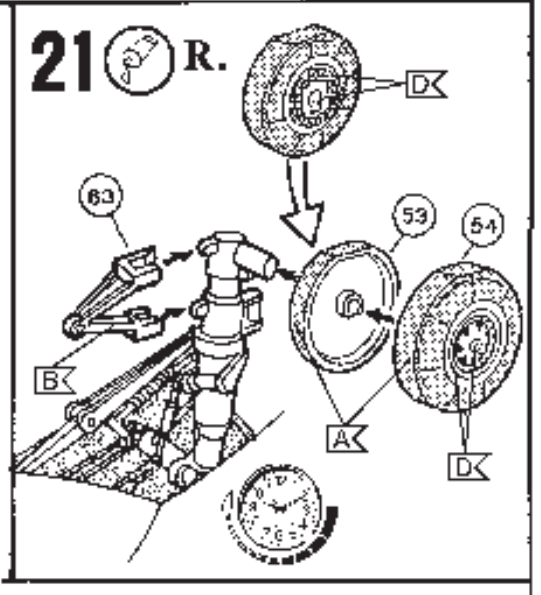
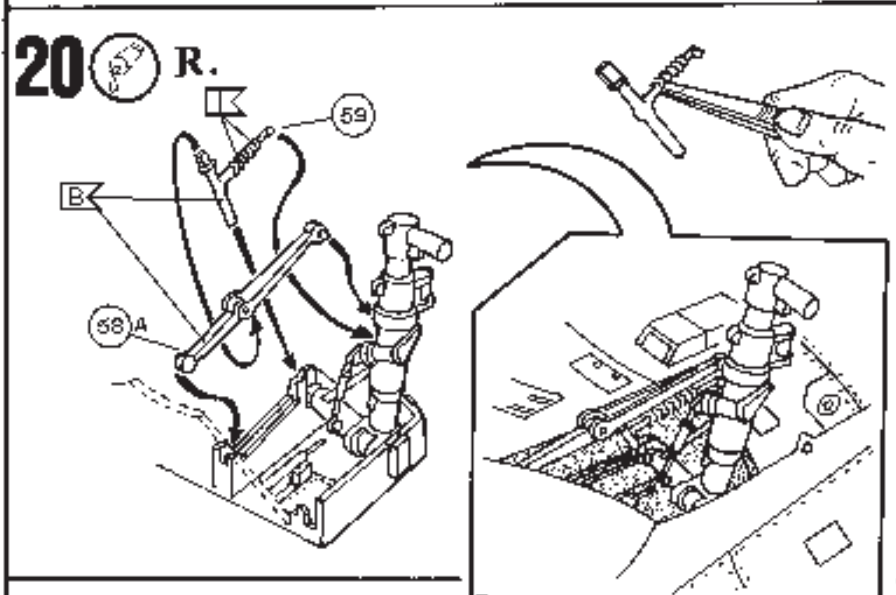
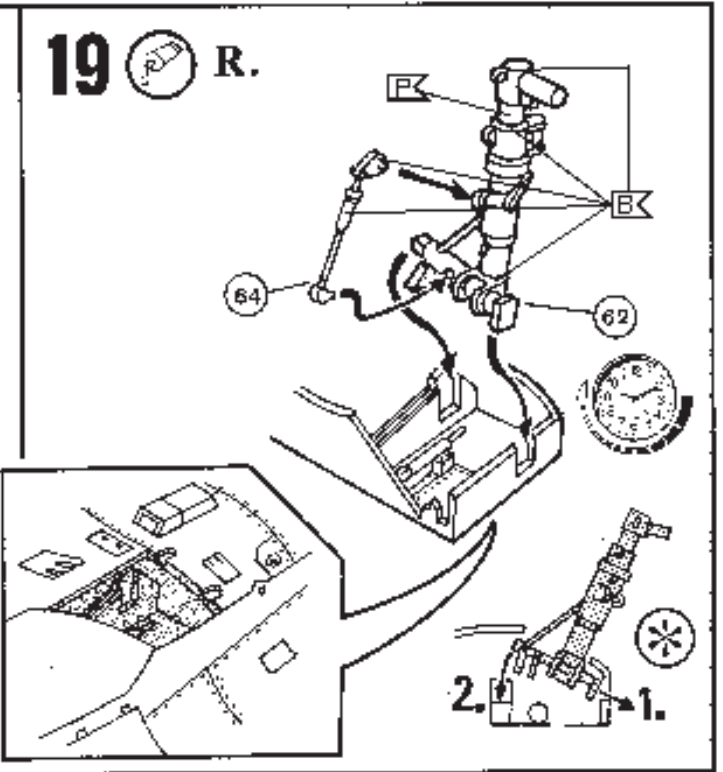
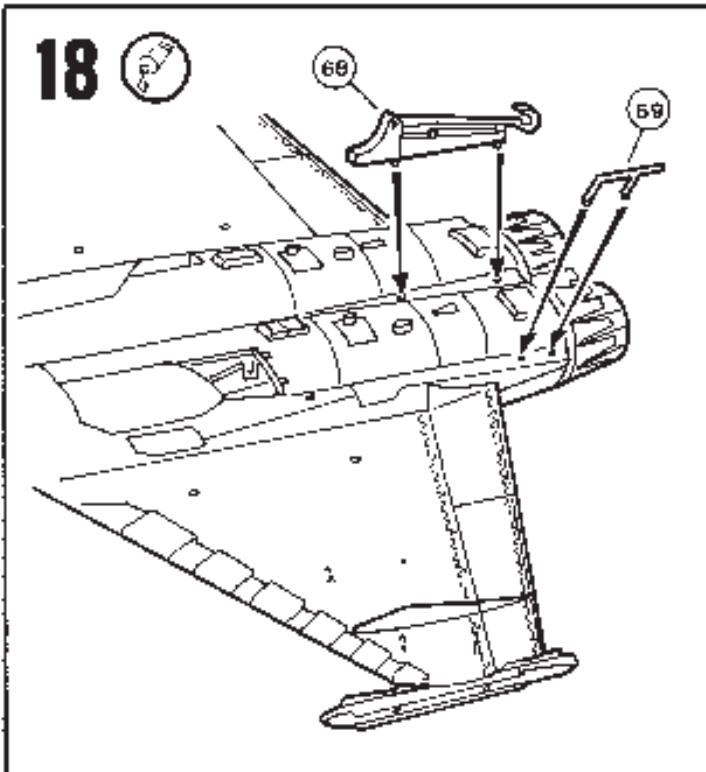

24 L.

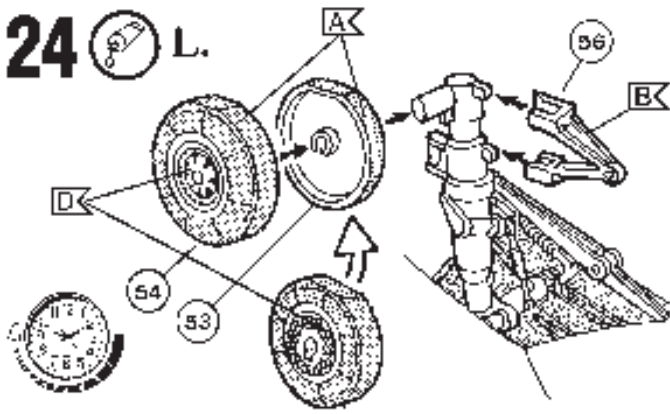

25 L.

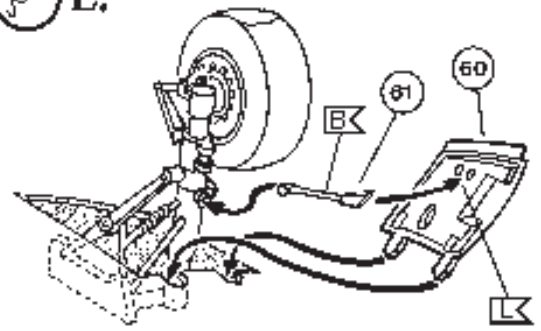

26 R.

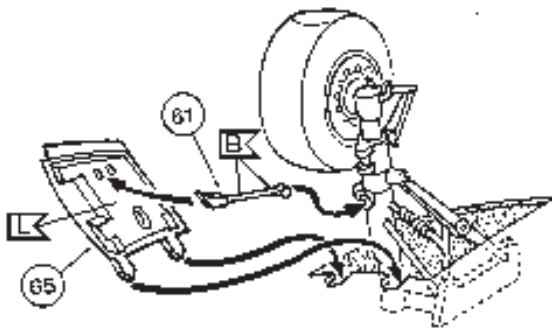

27 ?

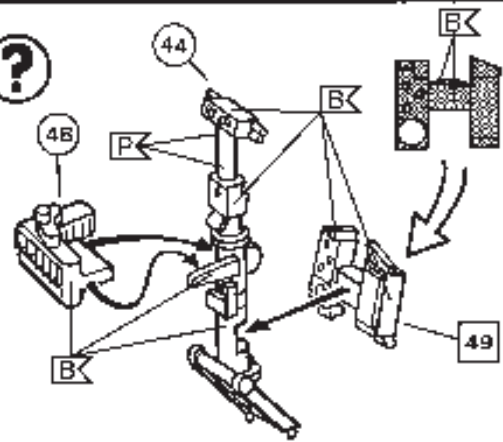

28

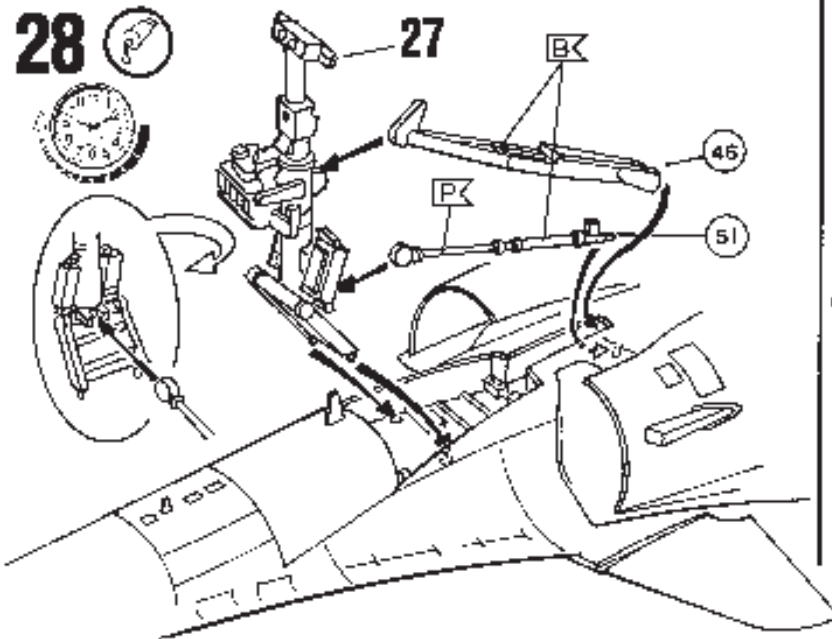

29

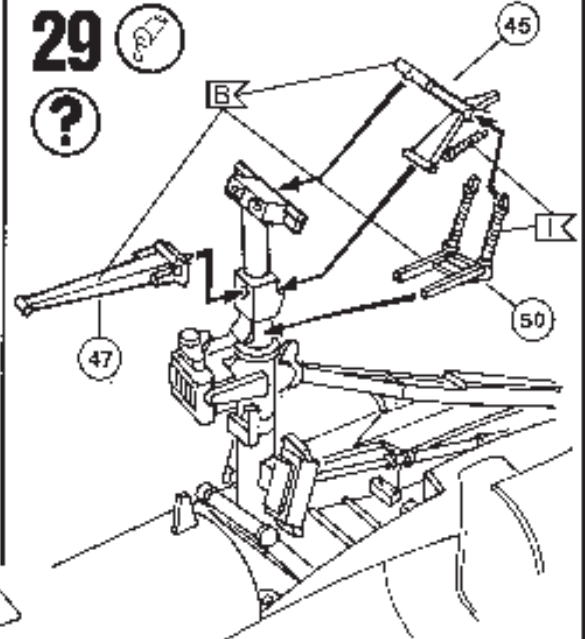

30 ?

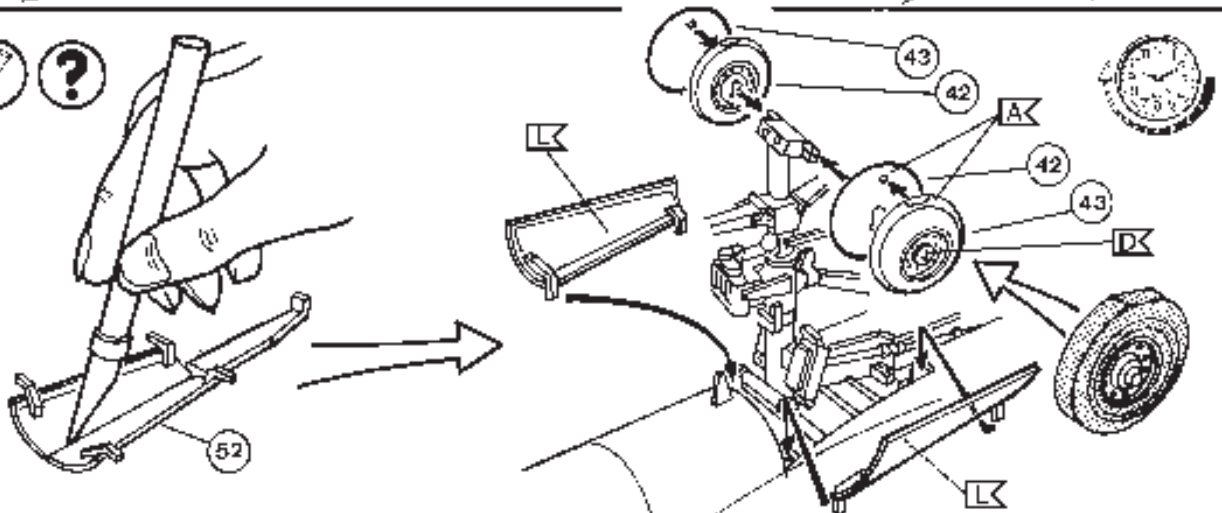

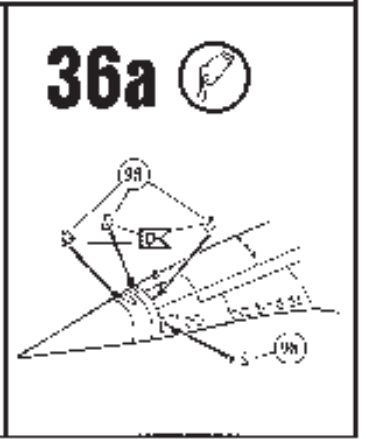
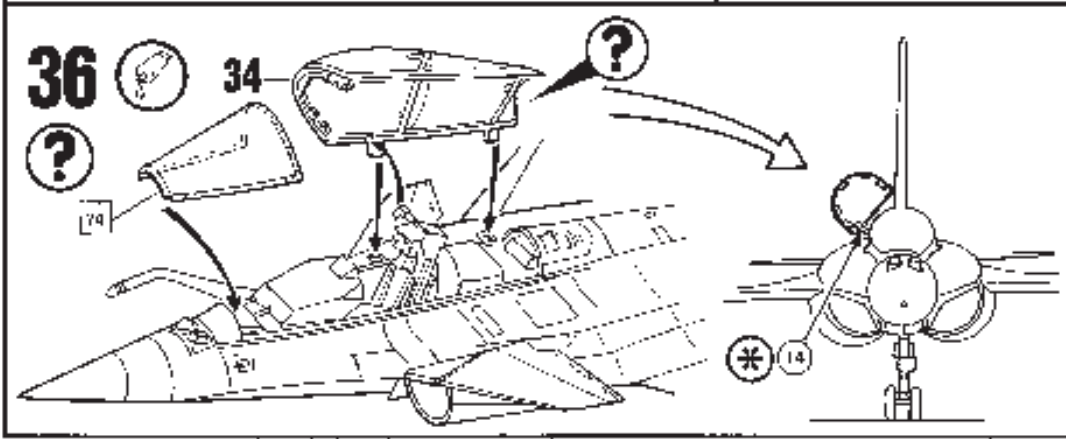
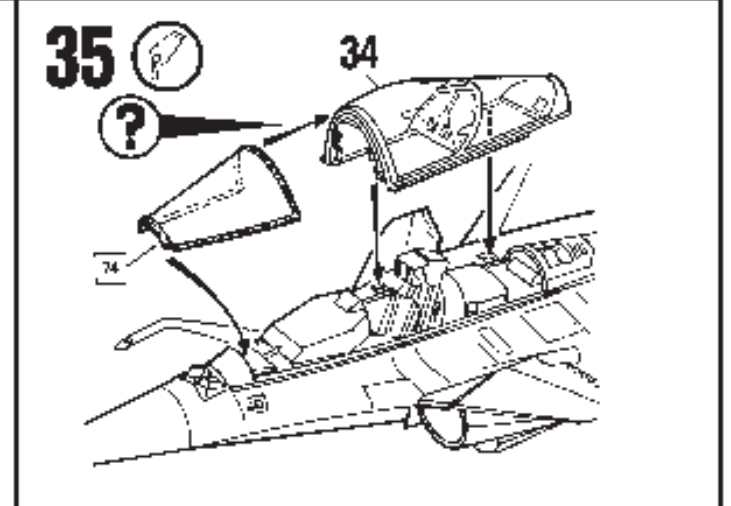
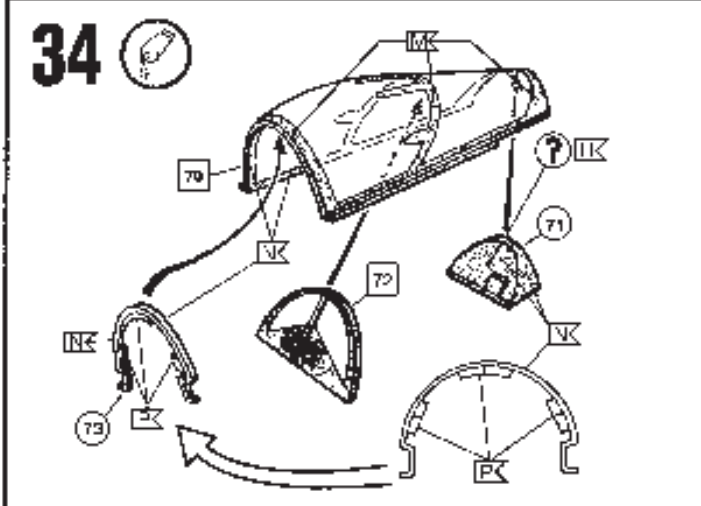
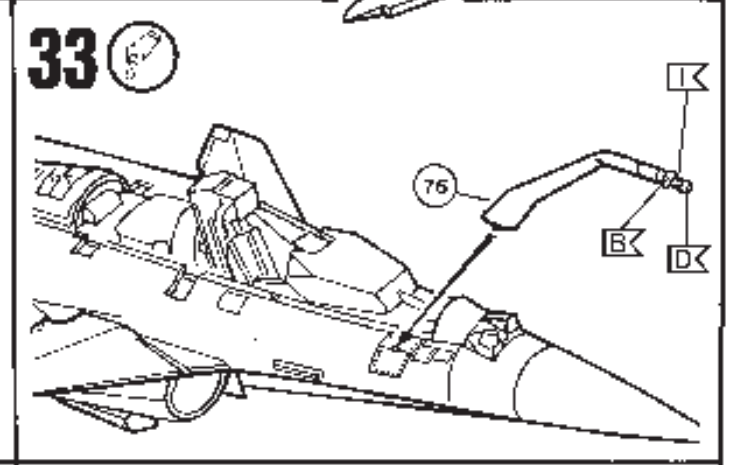
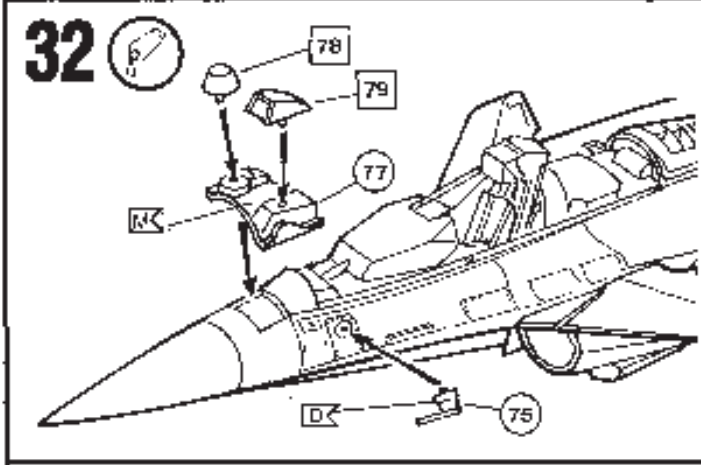
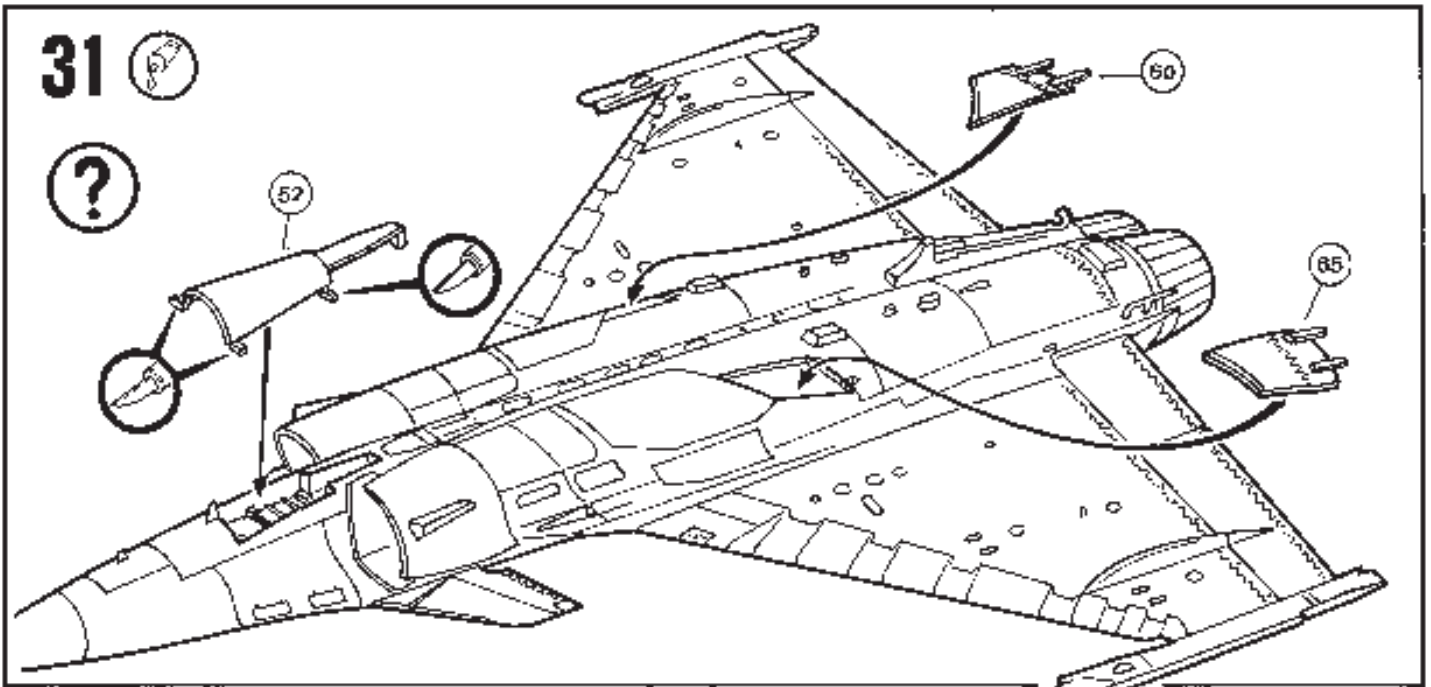

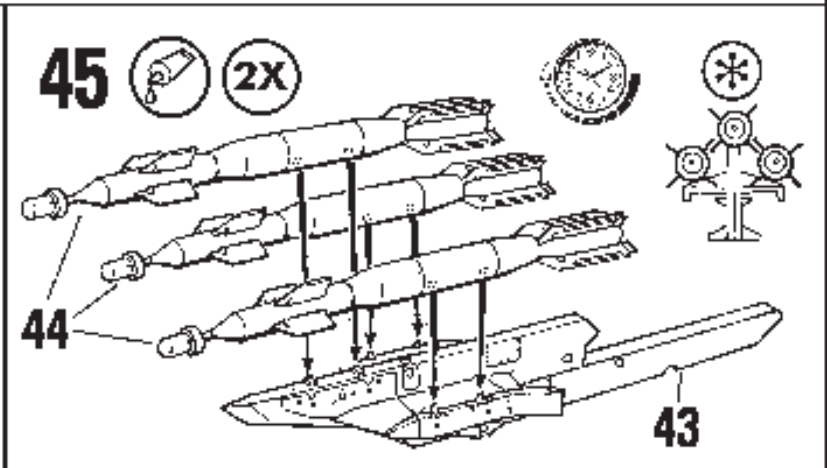
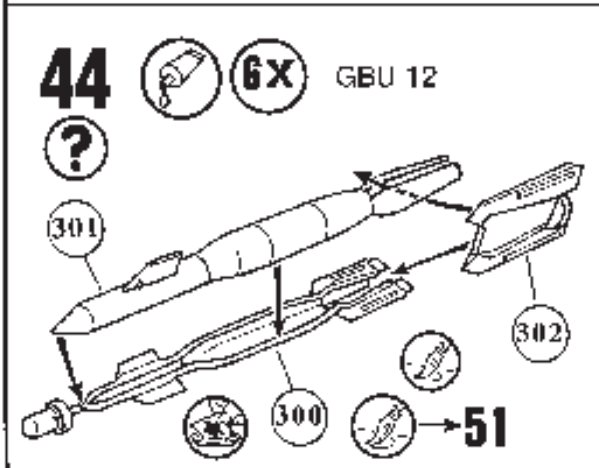
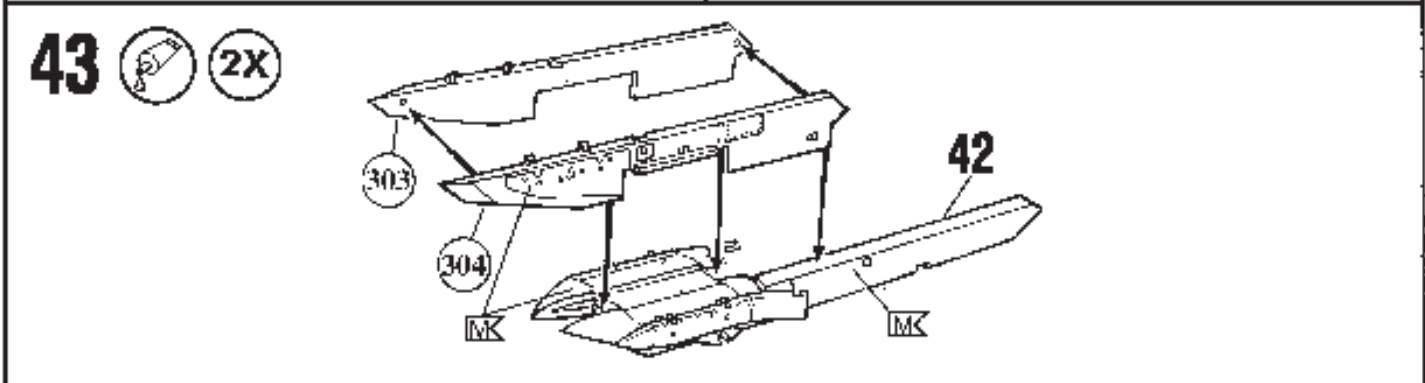
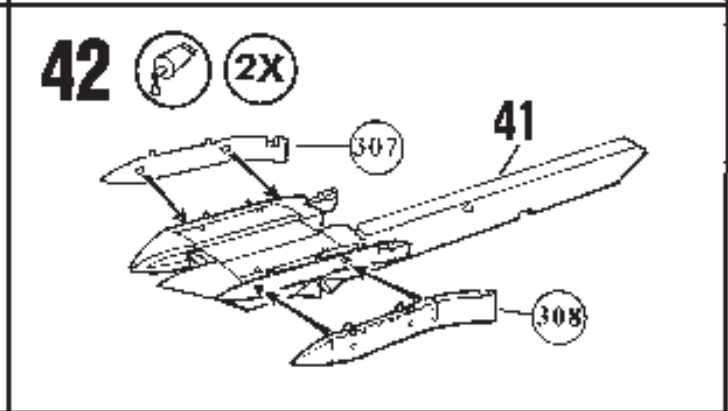
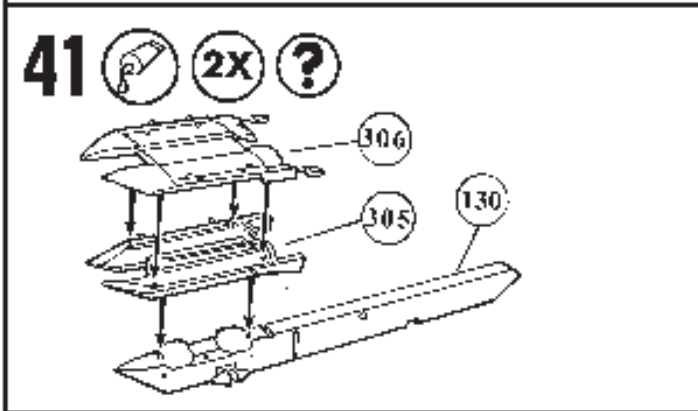
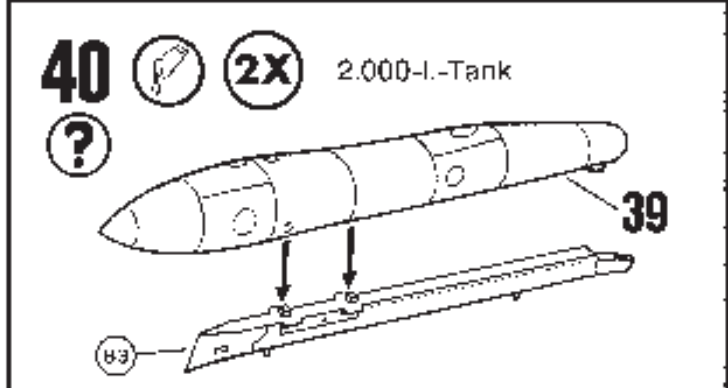
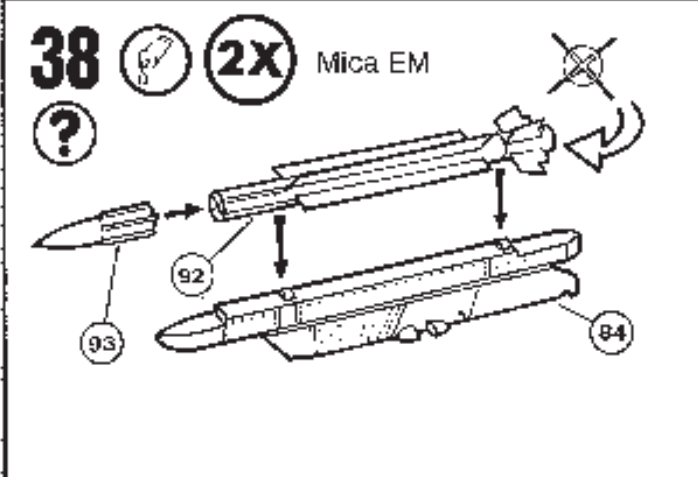
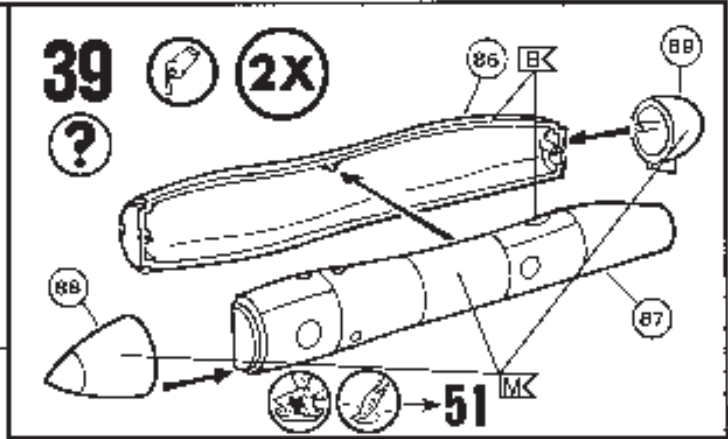
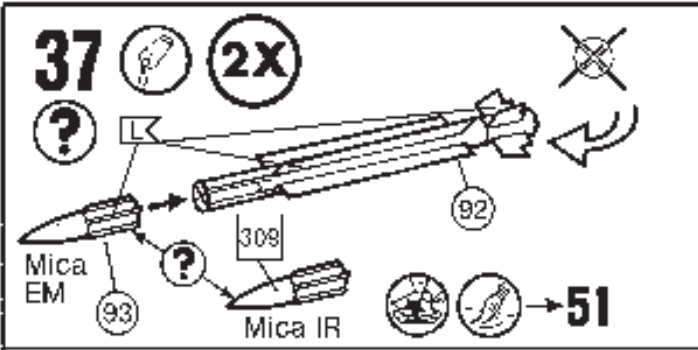

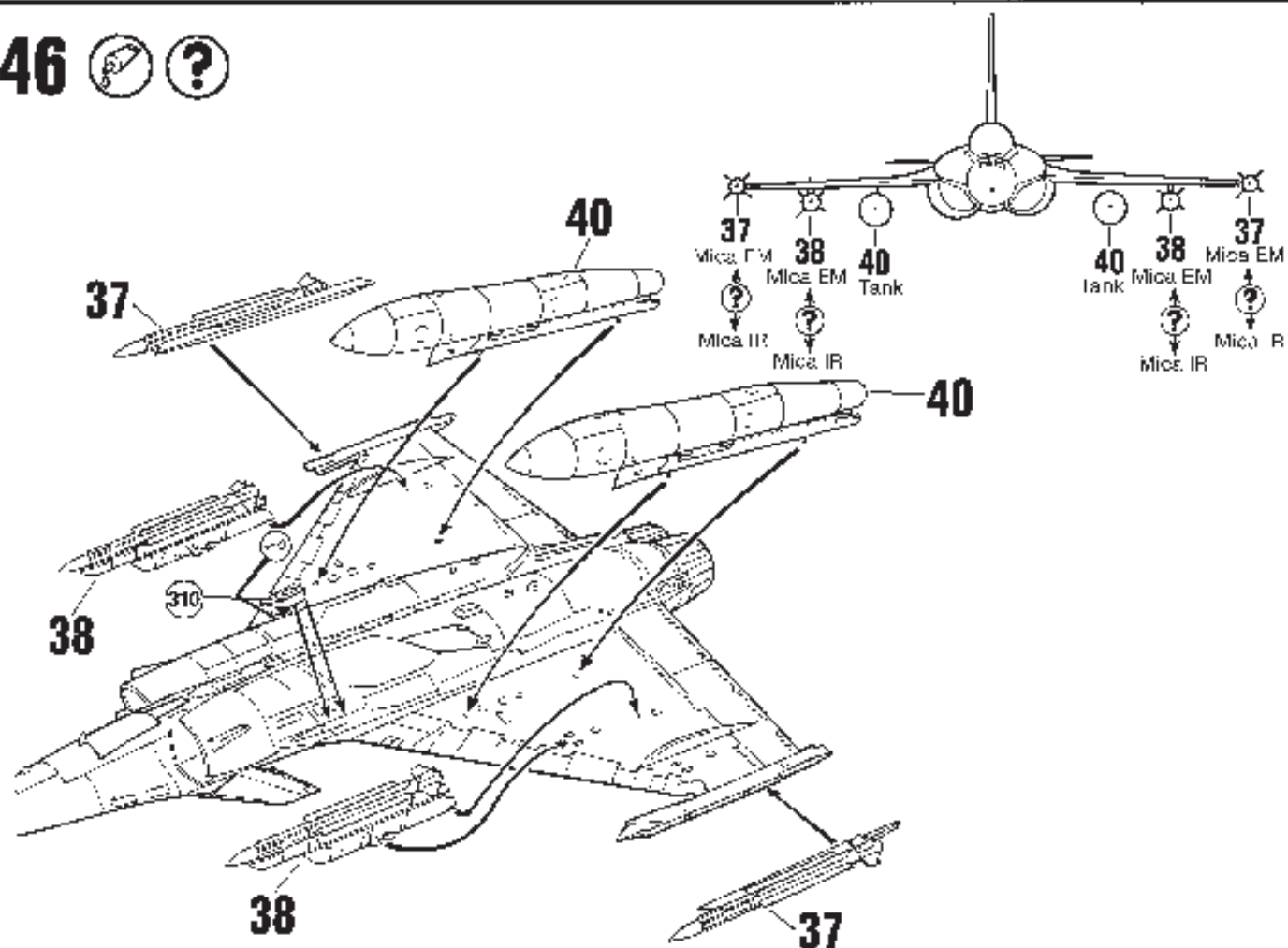
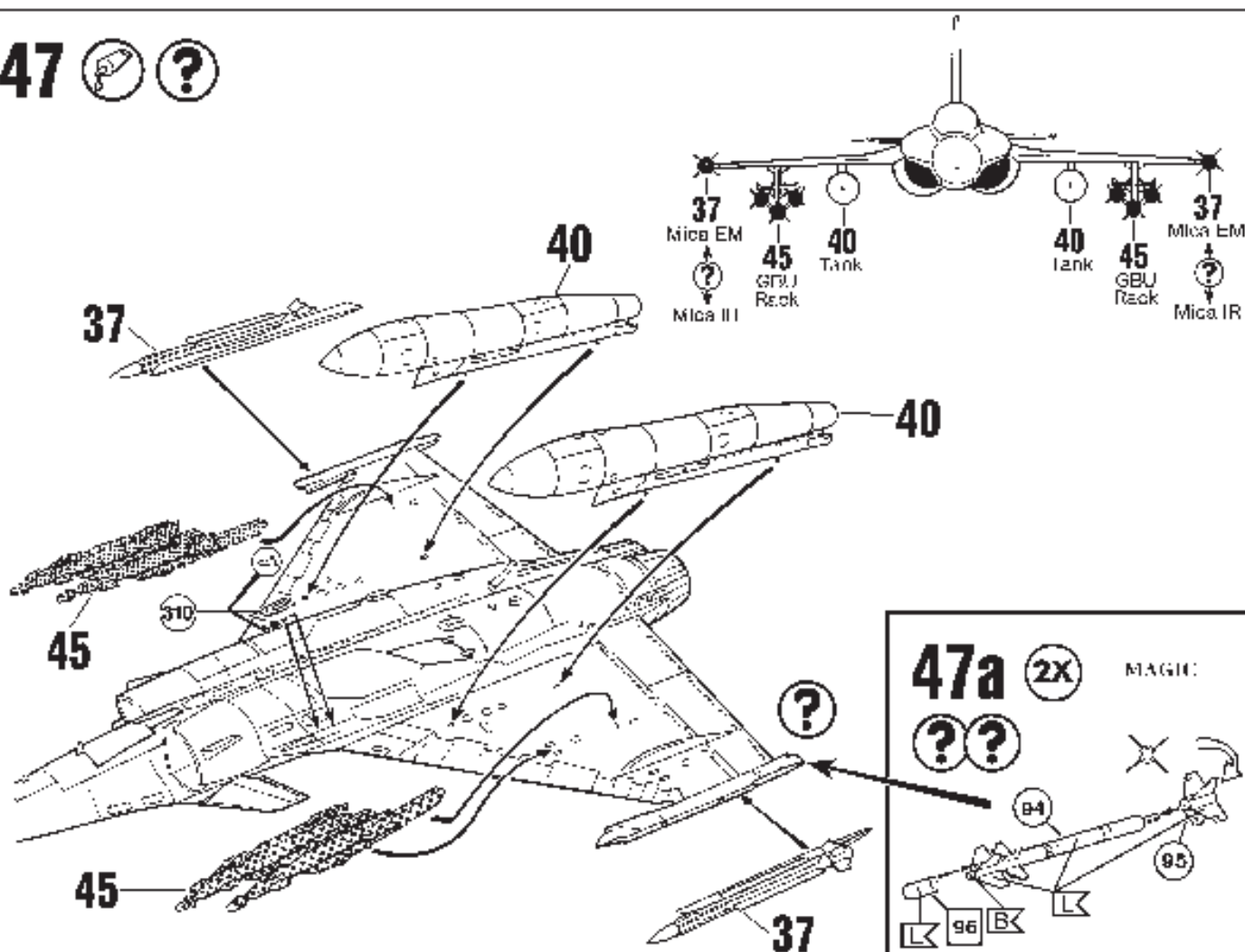
46  47  

48



Dassault Rafale M - General decals

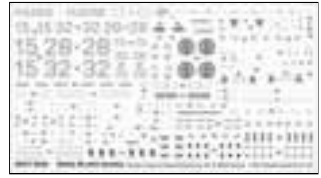
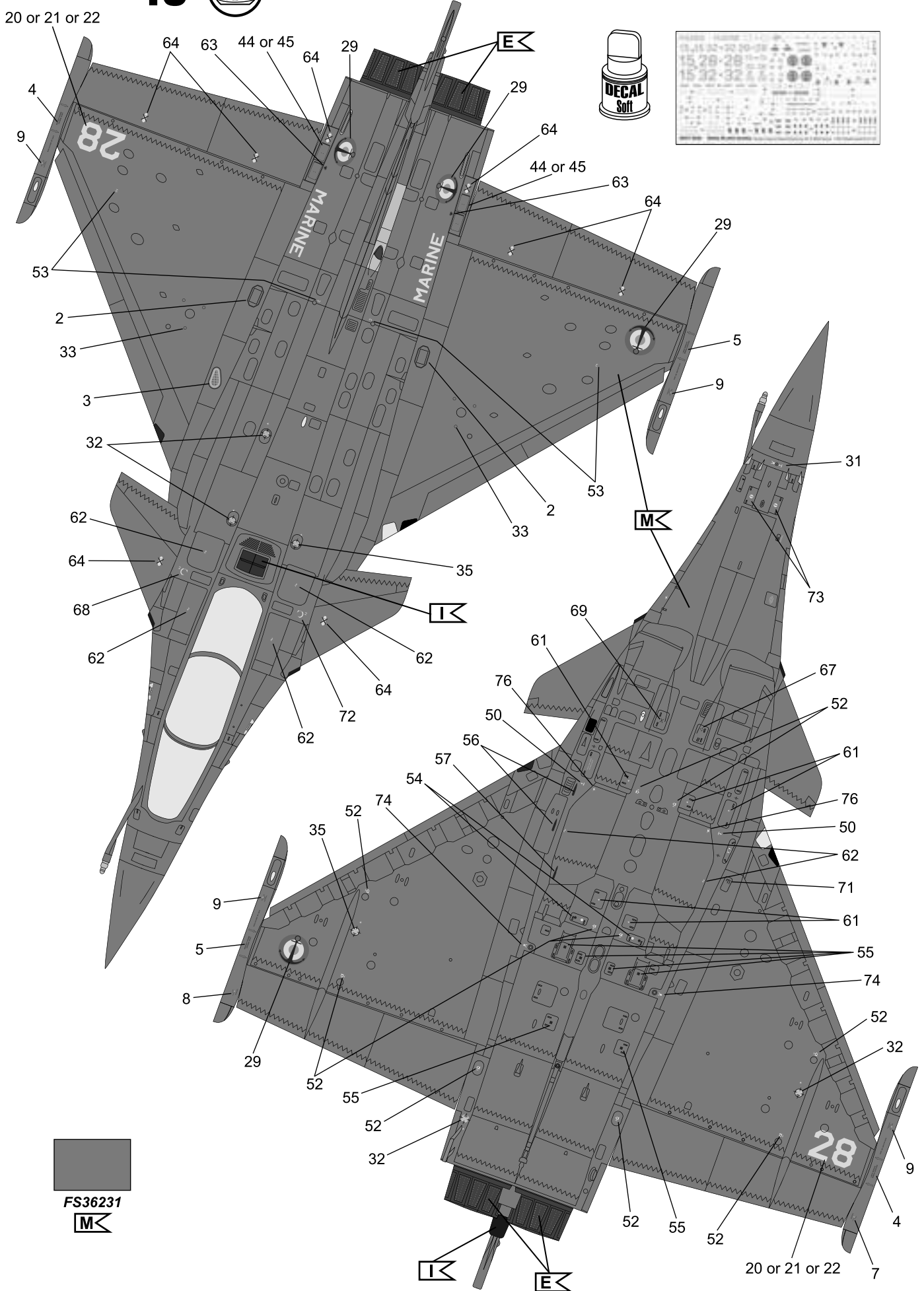

FS36231



49



Dassault Rafale M #15 - Operation Harmattan Flottille 12F - R91 Charles de Gaulle - Lybia 2011

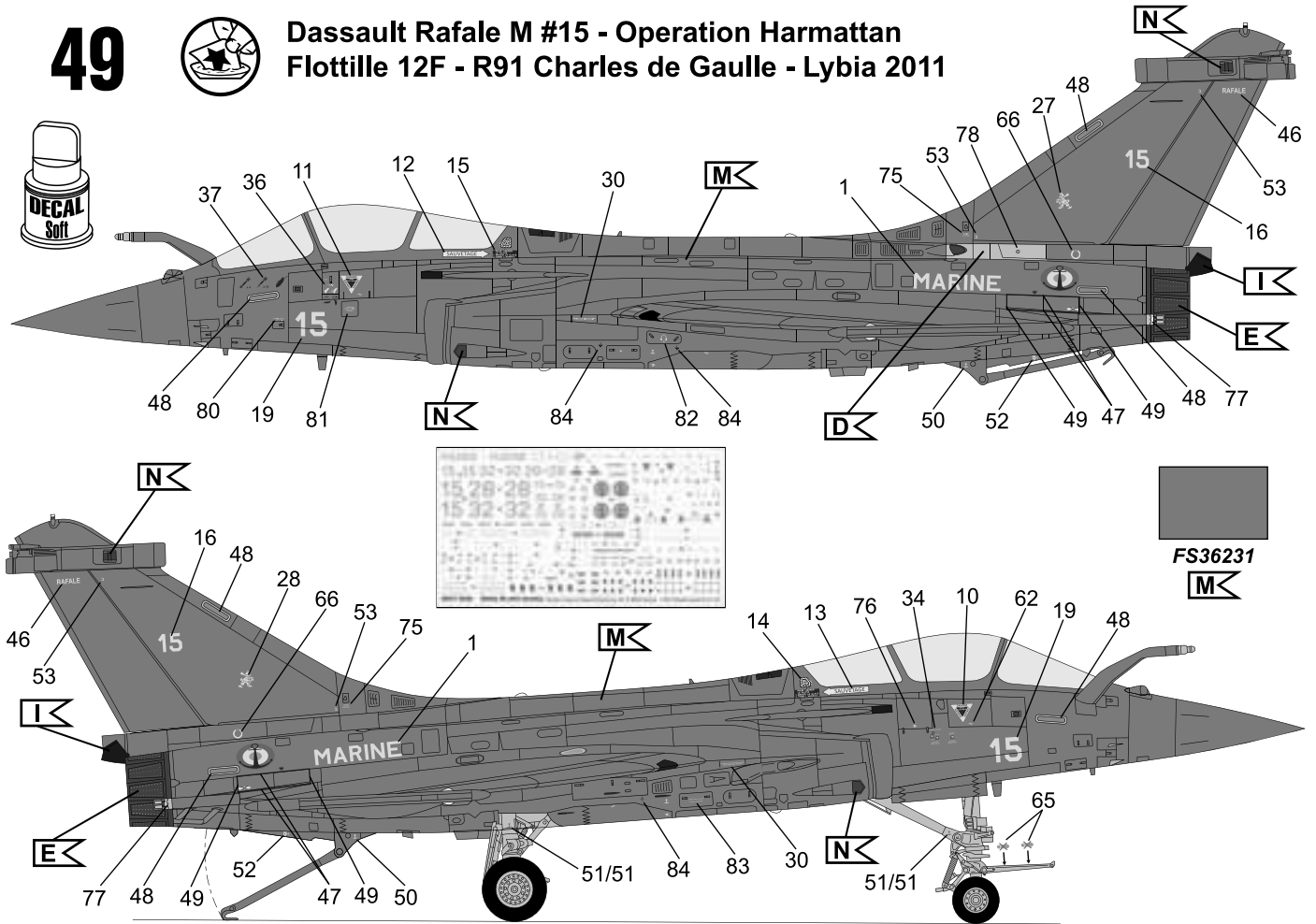

50



Dassault Rafale M #32 - First Rafale on Flottille 11F BAN Landivisiau - February 2012

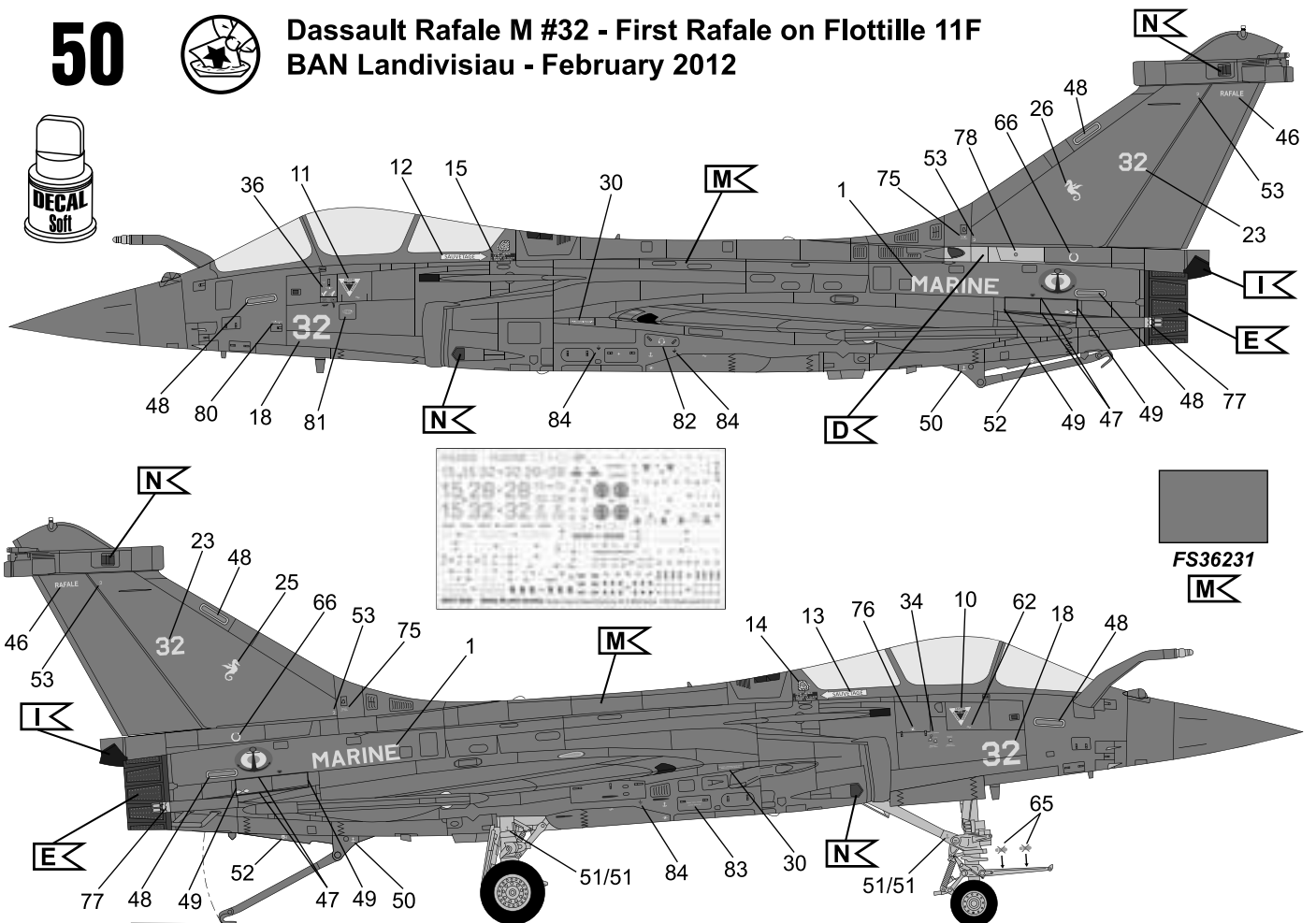

51



Dassault Rafale M - Weapons & fuel tanks

GBU-12 Laser guided bomb

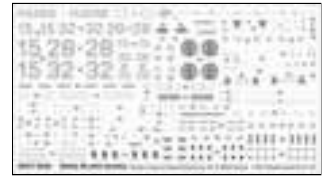

Right view

Left view

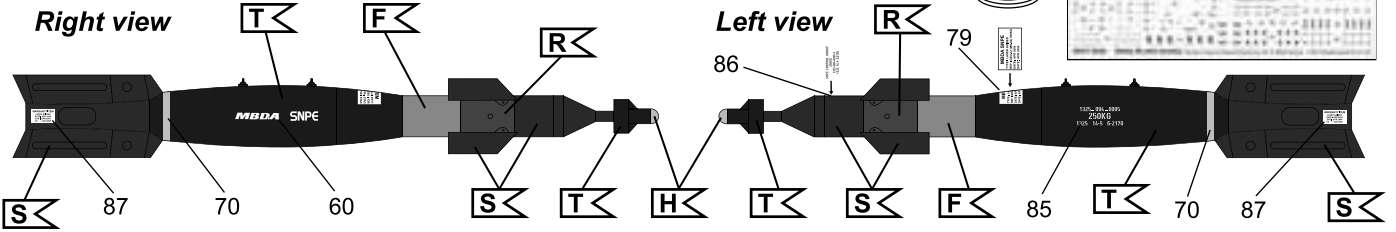

Air to Air Missile MICA EM

Air to Air Missile MICA IR

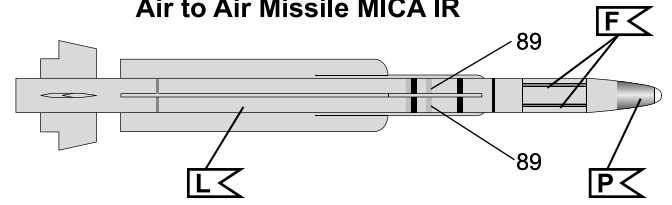
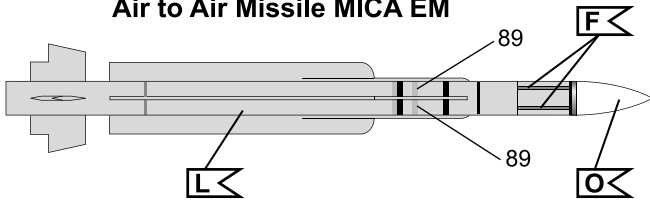

Fuel Tank 2000L

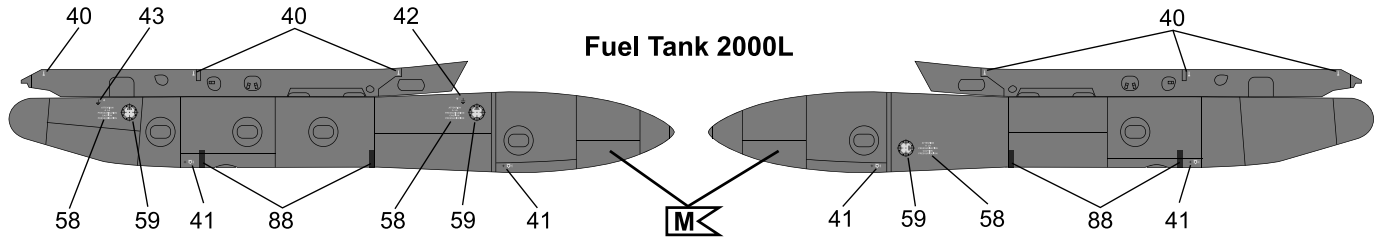

52



Dassault Rafale M #28 - DET CEPA (Tests & Experimentations) 100 Ans Aéronavale - BAN Hyères-Le Palyvestre July 2010

