

Alcatel F890 Voice



USER'S GUIDE

For more information, you can download full user guide or get on-line assistance: www.alcatel-home.com

1. IMPORTANT SAFETY INSTRUCTIONS (XP1050)

When using your telephone equipment, basic safety precautions should always be followed to reduce the risk of fire, electric shock and injury, including the following:

- 1) Read and understand all the instructions.
- 2) Follow all warnings and instructions marked on the product.
- 3) Unplug this product from the wall outlet before cleaning. Do not use liquid cleaners or aerosol cleaners. Use a damp cloth for cleaning.
- 4) Do not use this product near water (for example, near a bathtub, kitchen sink, swimming pool).
- 5) Do not expose the telephone to direct sunlight or extreme cold environment. Do not put the telephone close to a heating source such as radiators, cookers, etc.
- 6) Do not overload wall outlets and extension cords as this can result in the risk of fire or electric shock.
- 7) NEVER use your phone outdoors during a thunderstorm-unplug the base from the telephone line and the mains socket when there are storms in your area.
- 8) Do not use the telephone to report a gas leak in the vicinity of the leak.
- 9) Use only the supplied NiMH (Nickel Metal Hydride) batteries! The operation's periods for the handsets are only applicable with the default battery capacities.
- 10) The use of other battery types or non-rechargeable batteries/primary cells can be dangerous. These may cause interference and/or unit damages. The manufacturer will not be held liable for damage arising from such noncompliance.
- 11) Do not use third party chargers. The batteries may be damaged.
- 12) Dispose of batteries safely. Do not immerse them in water, burn them, or put them where they could get punctured.

1.1. Package Contents

The package contains the following items:

- Alcatel F890 Voice handset
- Alcatel F890 Voice base unit
- AC power adaptor
- Telephone line cord (with T plug for France)
- 2 NiMH rechargeable battery cells
- 6 User Guides
- Additional telephone plugs

The additional duo and trio package contain the following items:

- Handset(s)
- Charger(s)
- Mains power adapter(s)
- Rechargeable battery cells

1.2. Location

For maximum coverage and reduce the interference, here are some guidelines you should consider when you place the base unit,

- place it at a convenient, high, and central location with no obstructions between the handset and base unit in an indoor environment.
- place it away from electronic appliances such as televisions, microwave ovens, radios, personal computers, wireless devices or other cordless phones.
- avoid facing radio frequency transmitters, such as external antennas of mobile phone cell stations.
- avoid plugging it into the same circuit as other major household electrical appliances because of the potential for interference. Try moving the appliance or the base unit to another power outlet.

If the reception for a base unit location is not satisfactory, move it to another location for better reception.

Depending on the surrounding conditions as well as spatial and structural factors, the range may be reduced. The range indoors is normally less than outdoors

2. INSTALLING YOUR PHONE

2.1. Installing and Charging the Batteries

- 1) Slide down to open the battery compartment cover.
- 2) Place the 2 supplied rechargeable batteries as indicated. Pay extra attention to direction of polarity.
- 3) Slide the battery compartment cover back.
- 4) Put the handset on the base and charge for 15 hours before using the handset for the first time. The handset will give a beep when it is properly placed on the base or charger.

Notes:

- 1) Use only the supplied NiMH rechargeable battery cells.
- 2) If the handset will not be used for a long time, disconnect and remove the Battery pack to prevent possible leakage.

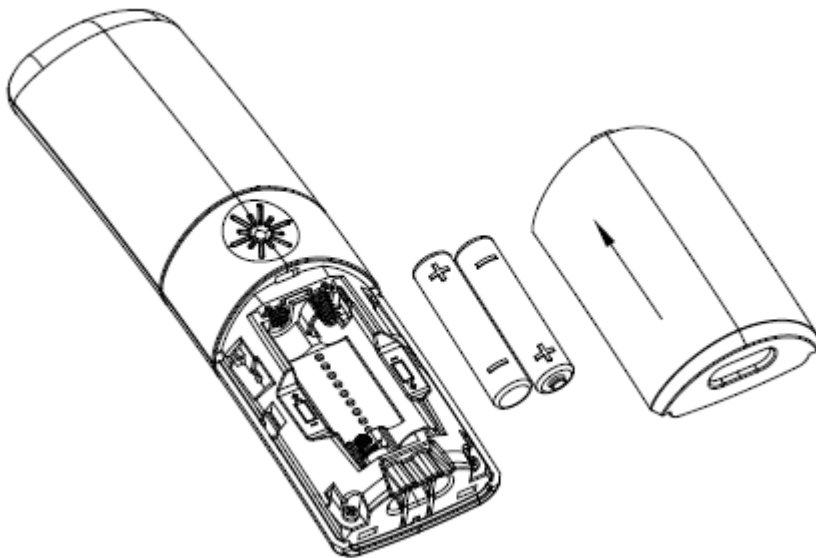

2.2. Connecting the Base Station

- 1) Plug one end of the telephone line cord into the telephone jack on base bottom.
- 2) Plug the small end of power adapter into a power jack on base bottom.
- 3) Plug the large end of power adapter into a wall power outlet.
- 4) Plug the other end of the telephone line cord into the telephone jack or micro-filter.
- 5) Always use the cables provided in the box.

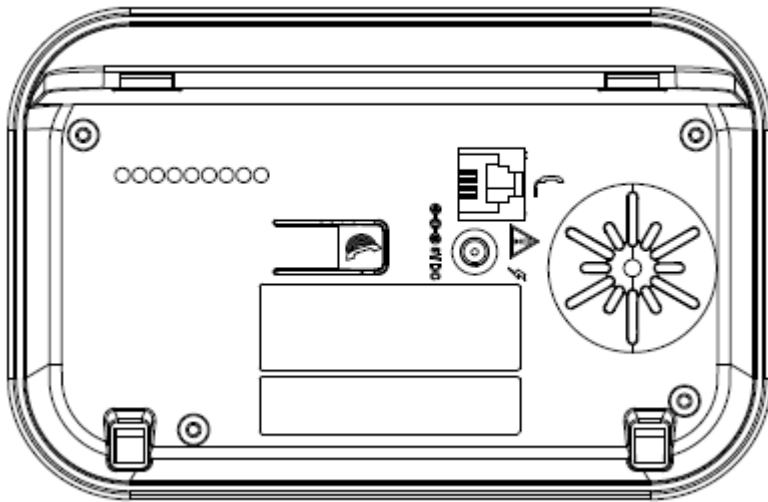

If you have broadband service, a micro-filter (not included) is required.

2.3. Connecting the Charger(s) (for Duo/Trio models)

Plug the power adapter into a mains socket.

If you have a Broadband line

If you connect your telephone to a line with a broadband connection, you will need to insert a micro-filter between the telephone and the telephone line, otherwise you may get interference between the telephone and the broadband, which could cause problems.

In a fixed with broadband, every telephone must have a micro-filter connected, not just the one at the telephone point that your modem is connected to. If you need more broadband micro-filters, contact your broadband supplier.

GETTING TO KNOW YOUR PHONE

2.4. Handset Overview

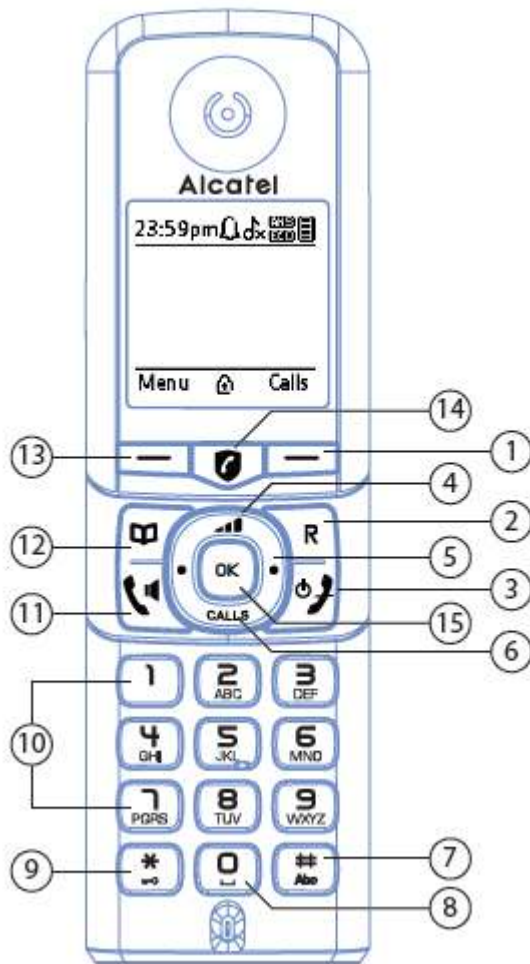

1. <-> (Right option)

- Press to confirm the option displayed on the screen above the button, delete or go back to the previous screen.
- In answer machine mode: Delete the current message playing.
- In idle mode: Press to scroll through your calls history

2.<R>

- Press to access to operator services*

3. <3>

During a call: Press to end a call and go back to idle screen.

In menu/editing mode: Press to go back to idle screen.

In idle mode: Press and hold for 7 seconds to turn on or off handset

4.<4>

In idle mode: Press to enter the ring volume control.

In menu mode: Press to scroll up the menu items.

During a call: Press to increase the volume.

5.<5>

In setting mode: Press left or right key to scroll to confirm settings.

6.<6>

In idle mode: Press to enter call lists (incoming and outgoing)

In menu mode: Press to scroll down the menu items.

During a call: Press to decrease the volume.

7.<7>

In editing name: Press to switch different input text modes (Abc, abc, ABC, 123).

8.<8>

In editing name: Press to add a space.

9.<9>

In idle mode: Press and hold to activate key lock or deactivate key lock.

10.<10>

In idle mode: Press and hold to dial a stored number in key 1 to 9.

11.<11>

During a call: Press to turn on/off the speakerphone.

In Idle mode/predialing mode/Call list/Phonebook entry: Press to make a call with speakerphone

12 <12>

In idle mode: Press to access contacts (phonebook).

13.<13> (Left option)

Press to enter the main menu, access sub-menus and confirm options shown on the display above the button.

14.<14>

In idle mode, press to enter the Call Control menu.

When receiving a call*: Press to send the call to the answer machine. Or,

During a call: Press to end the call. The number will be blocked and added to the blocked number list*.

15. <15>

In idle mode, press to access a high-lighted event e.g. missed calls and answer phone messages on the display.

In setting mode, press to confirm.

3.2 Base Station Overview

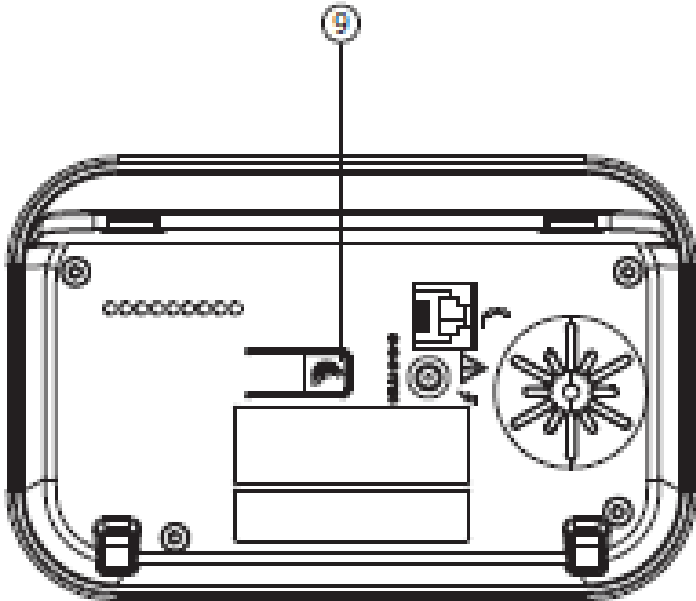
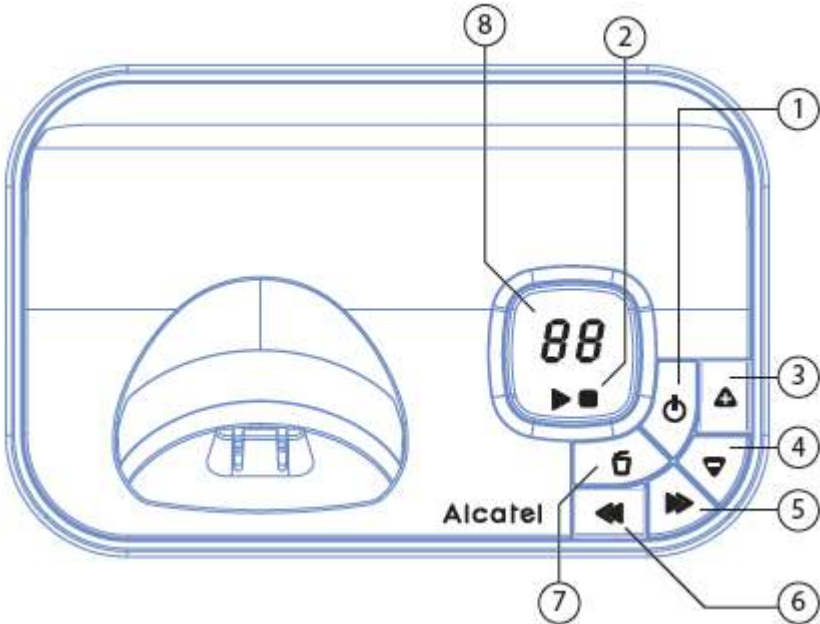

1. <TAM ON/OFF>
Press to turn on the answering machine.
Press again to turn off the answering machine.
2. <PLAY / STOP>
Press to play the message
Press again to stop message playback
3. <VOLUME UP (+)>
Increase (+) speaker volume during message playback
4. <VOLUME DOWN (-)>
Decrease (-) speaker volume during message playback
5. <SKIP FORWARD>
Press to skip the current message and play the next message
6. <SKIP BACKWARD>
Press to skip backward to the previous message.
7. <DELETE>
Press once to delete the message during playback
Note: New voice messages will not be deleted.
8. 7-SEG LED DISPLAY
 0F-> When answering machine is OFF.
 --
 -- When answering machine is OFF and no new TAM messages received
 0n-> When answering machine is ON where XX is number of messages in TAM memory.
 XX
 00 Steadily ON: No voice messages in TAM.
 XX Flash: There are XX new voice messages received where XX is from 01 to 58.
 ZZ Steadily ON: There are ZZ old voice messages kept in the TAM memory (no new voice messages).
 F Flash: The TAM memory is full.
 C /XX Flashing XX alternatively with C: Time is not set and there are XX new or old voice messages received where XX is from 01 to 58.
 XX Steadily ON: Playing the current XX incoming message.
 PL Steadily ON: Playing the current outgoing message (OGM) either the **Answer & Record** OGM or the **Answer Only** OGM.
 r Flash: new incoming message or memo is now recording.
 A Flash: Remote access is in progress.
 XX Flash: Indicate current volume level XX(01-05) which is flashing at 0.5s,.
9. <PAGE>
Press to page your handset(s). It will ring for approximately 60 seconds.
Press and hold to enter registration mode for 5 seconds

2.5. LCD

There are 2 modes of LCD screen in standby mode:

2.5.1. Clock mode (appears when idle mode is kept idle over 30 seconds)



2.5.2. Idle mode (Idle screen)



Show how much battery level. Scrolls when charging.



Flashes when battery needs recharging.



On: missed call(s) in the Calls list with number of calls displayed.



On: answer machine message(s) received with number of messages displayed.





On - alarm is set.

Flashing - alarm time has been reached.

Off - alarm off.

 The keypad is locked.

 Handset ringer is switched off.

 = outgoing call made

 = incoming call received

 = missed call

 = voice message

 = New voice mail

 = for a number in the call list, indicates that this number is blocked

4. USING YOUR PHONE

4.1. Follow the set-up Wizard

Follow the set-up wizard to set the time and date, record your outgoing message for the answer machine, set up call blocking and add contacts. Keep following the prompts until you've completed the set-up wizard.

4.1.1. Select Country

While this phone power up in first time, the handset will show “**Select country**” before Setup wizard. In **Select country** window, user can select below countries (in native language) by pressing <Up> or <Calls> .

After user selects the country, the language will be set according to the country.

E.g, if FRANCE is selected, French will be set in afterwards of setup wizard flow.

After “**Select country**” has been set in 1 handset and start setup wizard, the other handset will exit **Select country** and use same country settings with base.

You have following countries to be select:

FRANCE

ESPAÑA

ITALIA

DEUTSCHLAND

NEDERLAND

PORTUGAL

If you selected wrong country setting, you can follow the steps below to select right country setting again:

1. Select **Menu**, press <up> or <calls> to select

FR	ES	IT	DE	NL	PT	EN
----	----	----	----	----	----	----

Réglages	Ajustes	Impostazioni	Einstellungen	Instellingen	Definições	Settings
----------	---------	--------------	---------------	--------------	------------	----------

2. Press **Sélect (FR) / Selecc.(ES) / Selez.(IT) / Ausw.(DE) / Kies (NL) / Selec (PT) / Select (EN)**.

3. Press <Calls> to highlight

FR	ES	IT	DE	NL	PT	EN
Restaurer	Restaurar	Reset	Zurücksetzen	Reset	Reiniciar	Reset

4. Press **Sélect (FR) / Selecc.(ES) / Selez.(IT) / Ausw.(DE) / Kies (NL) / Selec (PT) / Select (EN)**,

5. Press <Calls> to highlight

FR	ES	IT	DE	NL	PT	EN
Prog. Base	Ajustes base	Impost. Base	Basis-Einstell.	Basisinstellingen	Def. da base	Base settings

6. Press **Sélect (FR) / Selecc.(ES) / Selez.(IT) / Ausw.(DE) / Kies (NL) / Selec (PT) / Select (EN)**,

7. Press **Oui (FR) / Si (ES, IT) / Ja (DE, NL) / Sim (PT) / Yes (EN)** to reset base settings back to default, then, **Select Country** menu will appear again.

4.1.2. Set the time and date

1. Select **OK** by pressing the left option button under the screen. The Setup Wizard will begin. Follow the prompts to complete the set-up process.

Please set the date and time to start using your telephone will appear.

2. Enter time.

3. Press **OK** to enter the date in the format DD/MM/YYYY.

4. Press **Save**. **Saved** will be displayed.

4.1.3. Set Call Blocking

1. Then, **Turn on Call Blocking?** is shown. Set Call blocking on now or turn it on later.

2. After pressing **Now** or **Later**, you are given the option to set other features.

3. When select **Now**, **Your phone's set to announce unknown callers' names when you answer so you...**, then press **OK**, **...can decide how to deal with calls. Change settings via Call Control, then press OK.**

4. **Do you have Caller Display?** Is shown. Press **Yes**, **Would you like us to guide you through some set-up tasks?** is shown. Press **Yes** or **No**.

5. When you press **Yes**, **Do you want to record answer phone outgoing message now?** is shown. Press **Yes** or **No**.

6. 3 types of sub-menus in **Answer & Record** menu are shown, **Record message**, **Play messages** and **use default msg.**

After setting **Answer & Record** menu by pressing **Done**, you then can add contacts list. **Do you want to add contacts list to their calls are allowed?** is shown. Press **Yes** or **No**.

7. After all setup is done, **Set up complete. Please read the quick start guide** is shown. Press **OK** to idle mode.

4.2. Make a Call

4.2.1. Preparatory Dialing

Enter the phone number and press <phone on> (or press the key twice in handsfree mode) to dial the number. Press **Clear** to clear the entry.

4.2.2 Direct Dialing

Press <phone on> to take the line and enter the phone number.

4.3. Answer a Call

When you receive a call, the phone rings and the display show Incoming call and "incoming call". If you've got a caller display service, the display shows the caller's number if it's available or the caller's name if it matches an entry stored in your contacts list.

If the handset is not on the charging cradle:

When the phone rings, press <phone on> (or press the key twice in handsfree mode) to answer a call.

If the handset is on the charging cradle or the base station and if **Auto answer** under **Call settings** is set to on: When the phone rings, pick up the handset to answer a call.

Or to block the call*, press <Block>, see Section 11 Call Control Settings.

*If you have subscribed to a Caller Display Service.

4.4. End a Call

During a call connection, press <phone off>.

OR

Put the handset on the base station to end a call.

4.5. Adjust Earpiece and Handsfree Volume

There are 5 levels to choose from for each of earpiece and handsfree volume.

During a call:

Press <up> or <Calls> to select volume 1-5. The current setting is shown. When you end the call, the setting will remain at the last selected level.

4.6. Mute a Call

You can talk to someone nearby without letting the caller hear you during a call.

During a call:

Select **Muted** by pressing right option key to mute the microphone and **Call Muted** will display on the LCD. Your caller cannot hear you. Select **Unmute** to unmute the microphone.

4.7. Temporary Ringer Silence

When the telephone is ringing, you can temporarily set silence for the ringer of the handset without disconnecting the call. The next call rings normally at the preset volume.

To silence the ringer:

- Select **Muted** by pressing right option key on the handset during ringing.

4.8. Redial

Each handset stores the last 30 dialed numbers (up to 30 digits each) in the redial list.

4.8.2. Review the redial list

1. Press <Calls> or Select **Calls** by pressing right option key in idle mode.
2. Press <up> or <Calls> to browse the list.

3. Press <phone off>key to exit.

4.8.3. Dial a redial entry

1. Repeat the step 1 to 2 in section 4.8.1.
2. Press <phone on> (or press the key twice in handsfree mode) to dial the selected number.

4.8.4. Delete a redial entry

1. Repeat step 1 and 2 in section 4.8.1.
2. Select **Options** by pressing left option key.
3. Press <up> or <Calls> to select **Delete Call**.
4. Select **Select** by pressing left option key to delete the displayed number. **Call deleted** will be shown. You hear a confirmation tone.

4.9. Find the Handset

You can locate the handset by pressing <page> on the bottom of base station.

All the handsets registered to the base will produce the paging tone and “**Base searching for handsets**” is displayed on the LCD. You can stop the paging by pressing <phone off>, or any dialing keys on any handset or <page>on the base again.

Note: If there is an incoming call during paging, the phone will ring with the incoming call instead of paging.

4.10. Call Waiting

If you subscribe to call waiting service with your telephone service provider, you hear a tone in the handset earpiece if someone calls while you are already on a call.

- Select **Switch** by pressing the Left option button to answer the new call and your first caller is put on hold.
- Select **Switch** to toggle between the two callers.
- Press <phone off> to end the current call.

4.11. Registration

Your handset and base station are pre-registered. If for some reason, the handset is not registered to the base station, **Searching for base** or **Not link to base. Please check base.** will be displayed on the handset screen, register your handset according to the following procedure.

Easy registration for additional handset (up to 4 handsets)

1. Select **Menu**, scroll down using the <Calls> to display **Settings** and press **Select**.
2. Press <Calls> to highlight **Registration** and press **Select**.
3. **Register** is highlighted, press **Select**.
4. Press and hold <page> on bottom of base until you hear a long beep from the base
5. Immediately, select **OK** on the handset. The handset will display Registering handset to indicate the base is in registration mode. If the system PIN is not 0000 then you will be prompted to enter it, then select **OK**.
6. Once registration is successful the handset will show **Handset x registered** (with X being the assigned handset number). The handset will then synchronize data with any other registered handsets, e.g. contacts, speed dials, handset names.

4.12. Deregister Handsets

If you want to replace a handset or reassign the designated handset number of a registered handset, you must deregister all the handsets and then individually register each handset.

1. Repeat step 1 to 2 of Section 4.11.

2. Press <Calls> to highlight **De-register** and press **Select**.
3. Press <Up> or <Calls> to highlight the handset you wish to de-register and press **Select**.
4. If the system PIN is not 0000 then you will be prompted to enter it, then select OK. If it is 0000, you will continue straight to point 6.
5. The display will show **De-registering handset** and once successful the display will confirm the handset has been de-registered

Notes:

- You cannot deregister the handsets if any other system handset is in use.
- If the deregistration process fails, you may need to reset the system and try again. To reset, unplug the power from the telephone base and plug it back in.

5. CONTACTS (PHONEBOOK)

You can store up to 200 entries in your list of contacts.

For each contact, you can save a home, mobile and work number. Contact entries will automatically be copied to any other handsets you have registered to the base. Any change made on one handset will be updated on all other handsets.

All handsets (if you have more than two handsets registered) and a list of the handsets registered to the base according to their default name/ number (e.g. Handset 2 or 3 etc.) or name if you have stored one.

5.1. Add a New Contact entry

1. From the idle screen, press <phonebook>.
 2. Select **Options. Add contact** is highlighted, press **Select**.
 3. Enter the new contact name using the keypad as per Character map below, then press <Calls> to select 3 fields (**Home, Mobile** or **Work**) and then enter the phone number.
 4. You can then press <Calls> and enter another number in other fields and then a work number if you want to. Select **Save** when you've finished.
- The display will show **Contact saved**.

Character map

0 space 0 + £ \$ # *

1 & . ' ? ! " @ 1

2 a b c 2 à á â ã ä å ç

3 3 d e f 3 è é ê ë

4 4 g h i 4 î ï ï í

5 5 j k l 5 £

6 6 m n o 6 ö ô ò ó õ ø ñ

7 p q r s 7 \$ ß

8 t u v 8 ü ù ú û

9 w x y z 9

& . ' ? ! " + = - ; : # * £

\$ € ¥ % () @ / _ \ < > ~

Changes text entry mode sentence case, upper or lower)

5.2. View/Dial a contact

1. From the idle screen, press <phonebook> to open your contact list.
2. Press <Up> or <Calls> to scroll through and view the entries.
3. To dial an entry, press <phone on> when the entry is highlighted. If entry has more than one number saved, you will need to highlight the number you want by pressing <Up> or <Calls> and then press <phone on> again.

5.3. Edit a contact

1. From the idle screen, press <phonebook> to open your contact list.

2. Press <Up> or <Calls> to scroll to the entry you want to edit and select **Options**.
3. Press <Calls> to highlight **Edit contact** and press **Select**.
4. Edit the name by pressing Left or Right button to move cursor left or right and **Clear** to delete characters and use the keypad to enter new ones, then press <Calls> to move the cursor to edit any of the numbers you have stored, using **Clear** to delete digits and re-enter any new ones, then select **Save**. The display will show **Contact saved**.

5.4. Delete contact(s)

1. From the idle screen, press <phonebook> to open your contact list.
2. Select **Options**.
3. Press <Calls> until **Delete** is highlighted and press **Select**.
4. You can now either:
 - 3.1 Select which contact(s) to delete by scrolling <Calls> to highlight the contact and pressing <OK>. A tick will mark the contact for deletion. Once all the contacts you want to delete have been marked, select **Options**.

5.5. **Delete selected** will be highlighted, select **OK**, **Delete selected contacts from all handsets** is shown. then select **Yes** to confirm.

3.3. Or, to delete all contacts, select **Options** and scroll down using the <Calls> button to highlight **Select all**, then select **OK** then press **Options**, **Delete Selected** is highlighted, press **OK** to confirm. **Delete selected contacts from all handsets** is shown. then select **Yes** to confirm. **All contacts deleted** is shown.

5.6. View the contact memory status

1. From the idle screen, press <phonebook>, then select **Options**.
 2. Press <Calls> until **Memory status** is highlighted and press **Select**.
- The display will show the percentage of the contact memory used, e.g. 35% Full.

6. SPEED DIAL

You can assign 9 of your phonebook entries to a speed dial location (1,...9). Key 1 is pre-stored as 3103 (Orange vocal message).

6.6. Save a Speed dial entry

1. From the idle screen, enter the telephone number you want to store.
 2. Then, either:
 - Press and hold the speed dial key 1 to 9 that you want to store.
- Or,

Select **Options**, scroll down using the <Calls> to highlight **Set speed dial** and press **Select**. Scroll down to the speed dial location number you want (1-9) and select **Save**.

The display will show **Saved** as speed dial x (x being the Speed dial button).

6.7. Dial a Speed dial entry

1. From the idle screen, press and hold the Speed dial key 1 to 9 that you want to dial.

☐

6.8. Edit a Speed dial entry

1. Select **Menu**, scroll down using <Calls> to display **Speed dial list** and press **Select**.
2. Press <Up> or <Calls> to highlight the entry you want to edit and select **Options**.
3. **Edit** is highlighted, press **Select**.
4. Edit the number by selecting **Clear** to delete digits and then enter any new digits. Select **Save**. **Saved as speed dial x** will be displayed.

6.9. Delete a Speed dial entry

1. Select **Menu**, scroll down using <Calls> to display **Speed Dial List** and press **Select**.
2. Press <Up> or <Calls> to highlight the entry you want to delete and select **Options**.
3. Scroll down to highlight **Delete** and press **Select**.
4. **Delete speed dial x?** is displayed, select **Yes**. **Speed dial x deleted** will be displayed.

7.Phone Settings

7.1. Handset Settings

7.1.1. Set Ringer melody and volume

1. Select **Menu**, press <up> or <calls> to select **Settings**,
2. Press **Select**, **Sounds** is highlighted
3. Press **Select**, **Ringing** is highlighted.
4. Press <Left> or <Right> to highlight the external melody you want, press <Calls> to select the internal melody you want from the 15 ringtones. Press <Calls> again to select the Announced call melody.
5. Press <Calls> again to select the volume level you want and select **Save** to save your choices.

7.1.2. Turn the alert tones on or off

1. Repeat step 1 to 2 of Section 7.1.1.
2. Press <Calls> to highlight **Alert tones** and press **Select**.
3. Press <Left> or <Right> to highlight **On** or **Off** for the Voice message alert and select **Save**.

7.1.3. Turn the handset tones on or off

1. Repeat step 1 to 2 of Section 7.1.1.
2. Press <Calls> to highlight **Handset tones** and press **Select**.
3. Press <Left> or <Right> to highlight **On** or **Off** for keypad tones and then press <Calls> to highlight **On** or **Off** for the Confirmation tones and select **Save**.

7.1.4. Change the handset display contrast

1. Select **Menu**, press <up> or <calls> to select **Settings**,
2. Press **Select**, press <Calls> to highlight **Display** and press **Select**.
3. Press <Left> or <Right> to select the level you want, then select **Save**.

7.1.5. Rename the Handset

1. Select **Menu**, press <up> or <calls> to select **Settings**,
2. Press **Select**, press <Calls> to highlight **Handset name** and press **Select**.
3. Edit the name by selecting **Clear** to delete the characters, then enter the new name, then select **Save**.

7.1.6. Change the display language

8. Select **Menu**, press <up> or <calls> to select **Settings**,
9. Press **Select**, press <Calls> to highlight **Language** and press **Select**.
10. Press <Up> or <Calls> to select the level you want, then select **OK**.

7.1.7. Change the call settings (Auto answer, Auto end call, Auto join and First ring)

1. Select **Menu**, press <up> or <calls> to select **Settings**,
2. Press **Select**, press <Calls> to highlight **Call settings** and press **Select**.
3. Press <Left> or <Right> to highlight **On** or **Off** for Auto answer and then press <Calls> to highlight **On** or **Off** for Auto end call, follow the same procedure for Auto join calls and First ring, then select **Save**.

7.2. Alarm

The clock is displayed on the handset screen in Clock mode.

If you have subscribed to a Caller Display service, the time and month will be set when you receive your first call but you will still need to set the year.

7.2.1. Set an alarm

1. Select **Menu**, scroll down using <Calls> to display **Clock/ Alarm** and press **Select**.
2. **Alarm** is highlighted, press **Select**.
3. Press <Left> or <Right> to display the alarm frequency you want: **Off, On once, On daily, Mon to Fri** or **Sat &Sun**.
4. Press <Calls> and enter the alarm time.
5. Press <Calls> and to select the melody you want. Select **Save**.

Stopping the alarm when it goes off

When the alarm goes off, the selected melody will play at an ascending volume.

The alarm will sound for 30 seconds and then the handset will return to idle, if the alarm isn't stopped or set to snooze, it will sound once more after 1 minute.

To stop the alarm, press <phone off> or select **Stop**.

To activate a ten-minute snooze, select **Snooze** or any other button (except <phone off> or **Stop**). You can set snooze as many times as you want until you select **Stop**.

7.2.2. Set time and date

1. Select **Menu**, scroll down using <Calls> to display **Clock/ Alarm** and press **Select**.
2. Press <Calls> to highlight **Time and date**, press **Select**.
3. Set Time and then press <Calls> to set date, then press **Save**.

7.2.3. Set time format

1. **Select Menu, scroll down using <Calls> to display Clock/ Alarm and press Select.**
2. Press <left> or <right> to select **12 Hours** or **24 Hours**, then press **Save**.

7.3. Base Settings

7.3.1. Set the base ring melody and volume

1. Select **Menu**, press <up> or <calls> to select **Settings**,
2. Press **Select**, press <Calls> to highlight **Base settings** and press **Select**.
3. **Ringing** is highlighted, press **Select**.
4. Press <Left> or <Right> to highlight the ring melody you want, then press <Calls> to select the volume level you want, then select **Save**.

7.3.2. Flash time

1. Repeat step 1 to 2 of Section 7.3.1.
2. **Flash time** is highlighted, press **Select**.
3. Press <up> or <Calls> to highlight **Short, Medium**, or **Long**, then press **OK** to confirm.

7.3.3. PBX access code

If you're connected to a PBX system, you might need to enter an access code (e.g. 9) before each number is dialed. Your phone can store an access code which is automatically dialed before each number stored in contacts, call log, speed dial.

1. Repeat step 1 to 2 of Section 7.3.1.
2. Press <Calls> to display **PBX Code**, press **Select**.
3. Enter the number you want (maximum 4 digits), then select **Save**.

7.3.4. Change the system PIN

1. Select **Menu**, press <up> or <calls> to select **Settings**,
2. Press **Select**, press <Calls> to highlight **Change Sys. PIN** and press **Select**.
3. If the current PIN is 0000, you will be prompted to enter the new 4-digit PIN, then press OK. (Or, if the current PIN is not 0000, you will be prompted to enter the old (current))
4. 4-digit PIN first and then select **OK**. Then follow the prompts and enter the new 4-digit PIN.
5. Enter the new 4-digit PIN again and select **OK**. The display will show **New system PIN saved**.

7.3.5. Reset the handset or base settings

1. Select **Menu**, press <up> or <calls> to select **Settings**,
2. Press **Select**, press <Calls> to highlight **Reset** and press **Select**.
3. **H/set settings** is highlighted, press **Select** or press <Calls> to highlight **Base settings** and then press **Select**.
4. **Reset <handset or base> settings back to default?** is displayed, select **Yes**.
5. Resetting <handset or base> Settings. **settings...** is displayed while the reset takes place. Once finished, **<handset or base> settings reset back to default** is displayed.

7.3.6. Clear the handset and base user data

1. Repeat step 1 to 2 of Section 7.3.5.
2. Press <Calls> to highlight **Clear user data** and press **Select**.
3. If the current system PIN is not 0000 you will be prompted to enter the PIN, then press OK. If it is 0000, you will continue straight to step 5.
4. **Delete data on all handsets and base?** is displayed, select **Yes**.
5. **Deleting all user data...** is displayed. Once finished, **All user data deleted** is displayed.

8. CALLER DISPLAY (Network dependent)

This feature is available if you have subscribed the Caller Line Identification service with your telephone service provider.

If your caller's name is stored in your contacts list and it matches the number calling, you'll see the caller's name and where they are calling from (i.e. Home, Mobile or Work) on the display instead.

If you receive a call from a number you have stored in your Blocked calls list, **Blocked** will be displayed under the name or number.

The Calls list can store up to 50 incoming (missed and answered) calls and 30 outgoing calls with date and time of the call. If you haven't subscribed to a Caller Display service, No number will be displayed in the Calls list for incoming calls but the time and date will be recorded.

Calls are listed in chronological order with the most recently received/ made call at the top of the list. When the list is full and a new call is received/made, the oldest entry will be deleted automatically. The Calls list can hold numbers up to 20 digits and names up to 25 characters.

Missed call notification

If an incoming call has been missed (i.e. not answered), the missed call icon will be displayed on the idle screen with the number of missed calls displayed, e.g. "missed call". You can clear the notification by viewing the calls list on any handset registered to the base.

The "missed call" will be presented for missed calls in the calls list so you can differentiate between calls.

8.1. View and access options in the Calls list

1. Press <Calls> or select **Calls**. The most recent entry is at the top of the list will be displayed.
2. Press <Up> or <Calls> to scroll through and view the list.
3. When the entry you want is highlighted, press <phone on> to dial.
4. To play an answer message, when the entry you want is highlighted, select **Options, Play message** is highlighted, press **Select**. The message will be played.
5. To block the number, when the entry you want is highlighted, either press <Block> or, select **Options**, scroll down to **Block number** and press **Select**. **Always block calls from this number?** Is displayed. Press **Yes** to confirm.
6. To Allow or Unblock a number via Calls List, when the entry you want is highlighted, press **Options** and select **Unblock number**. **Unblock number?** will be displayed, then select **Yes**.
8. If you haven't set up your access PIN yet, you will be prompted to follow the instructions. In Call list, a blocked number appears with a "blocked icon" before the number:

8.2. Save a Calls list entry to your contacts

1. Press <Calls> or select **Calls**,
2. Press <Up> or <Calls> to highlight the entry you want and select **Options**.
3. Highlight **Save number** and press **Select**.
4. You now have two options:
 - i) To save this as a new contact, highlight **New contact** and press **Select**. Highlight the type of number, then press **Select**. Enter the contact name and select **Save**.
 - ii) To add to an existing contact, highlight **Add to contact** and press **Select**. Scroll to highlight the entry you want and press **Select**. Highlight the number type where you want to save the number and press **Select**.

8.3. Delete an entry in or the entire Calls list

1. Press <Calls> or select **Calls**, then if you want to delete just one entry,
2. Press <Up> or <Calls> to highlight the entry and select **Options**. To delete the entire list, simply select **Options**

3. Press <Calls> to display either **Delete call** or **Delete all** and press **Select**. **Call deleted** will be displayed if you have deleted one entry.

4. if you chose to **delete all** then you will need to confirm by selecting **Yes**.

9. VOICE MAIL (NETWORK DEPENDENT)

By subscription to your operator, you can have your calls diverted to a voicemail box when you are absent. For more details, contact your operator.

When new voice mail message is received, an "voice mail" icon appear on the screen. The "voice mail" icon disappears once you have consulted the voicemail messages.

To reset the voicemail indicator:

1. Press and hold <5> in call list to delete Voicemail call from call lists. Prompts **Delete voicemail call?** will be displayed. Press **Yes**. **Voicemail call deleted** will be shown.

10. Make an Internal Call

This feature is only applicable where at least two registered handsets. You can register up to 4 handsets to the telephone base.

10.1. Make an internal call between handsets

1. Press <phonebook>, then press <Up> to scroll through and display the handset you want to call, then press <phone on> .

2. The receiving handset will ring, and your handset name will be presented on the screen.

3. To answer they need to press <phone on>. If it is not answered after 30 seconds, the call will end automatically.

10.2. Transfer a call

You can transfer an external call to another handset registered to the base.

1. During a call, select **Options**, then press <Up> to highlight **Transfer call** and press **Select**.

2. If you have one other handset it will ring, or

3. If you have more than one other handset, you can press <Up> or <Calls> to highlight the handset you want, then select **Call** and it will ring. Your external call will be put on hold.

4. When the other handset answers, you can announce the call and then select.

10.3. 3-way conference call

Using your handset, you can hold a 3-way conference call with two external callers*. Or, you can hold a 3-way conference call between 2 internal handsets and 1 external caller.

Once the 3-way conference call is in progress other handsets registered to the base can join the call by pressing <phone on>.

1. During a call, select **Options**. **Multi call** is highlighted, press **Select**.

2. Enter the number you want to call or press <phonebook> and scroll to the internal handset you want and then press <phone on> to call.

3. When the second call is answered, the first external caller will be put on hold.

4. Select **Join** and all callers will be joined in a 3-way call.

* This feature is available if you have subscribed the Caller Line Identification service with your telephone service provider.

11. Call Control Settings

Under the Call control menu, it has 4 sub-menus:

1. Call Blocking,
2. Do Not Disturb,
3. VIP list.
4. Change PIN

1. Call Blocking*

It allows you to block calls in three different ways (Announce, Ans.Phone, Custom)

2. Do Not Disturb

When **Do Not Disturb** is switched on, your calls will get through and show on the screen but your handset won't ring and the handset display won't light up.

3. VIP list*

It allows you to manage calls to and from your favorite/ important contacts. If the saved entry is VIP, "vip icon" will be added in front of name of contacts.

*This feature is available if you have subscribed the Caller Line Identification service with your telephone service provider.

4. Change PIN

- i. Press **Select**, **Please remember the Access PIN is used for both remote access and call control**.is shown, and then press **OK**.
- ii. Enter the old Access PIN, and then press **OK**.
- iii. Enter a new 4-digit PIN, and then press **OK**.
- iv. Confirm new PIN by entering new 4-digit PIN again, , then press **OK**, **Access PIN saved** is shown.

You will need to enter your access PIN to access the Call control menu. The default access PIN is 0000.

When press <Block> in idle mode in the first time, you should need to set your access PIN as

below:

1. **"You need to set your Access PIN before using call control..."** is shown. Press **OK**.
2. It further shows **"...The Access PIN is used for both remote access and call control."**
3. Press **Set PIN**, enter 4 digits, e.g. 1234 for example, Press **OK**
4. **"Confirm new PIN:"** is shown, enter the new PIN again, then press **OK**. **"Access PIN saved"** is shown.

11.1. Call Blocking

Your phone has 3 Blocking modes in Call blocking submenu to help you manage incoming calls:

1) Announce

All calls from operator, ringback and those not in your Contacts, Allow list or VIP list will hear **"Callers to this number are being screened by Call Blocking, please say your name after the tone then press # and wait to be connected"**.

Those on your Blocked list hear, **"Callers to this number are being screened by Call Blocking, the person you are calling is not accepting your call. Please hang up"**

2) Answering Phone

All calls not in your Contacts, Allowed list or VIP list are sent straight to the Answer Phone including those on your Blocked list.

3) Custom

You choose how you'd like to handle all your calls.

In Announce mode (default setting), your phone will filter all first time calls from numbers that are not yet saved in your Contacts, or not on your allowed list. By doing this, you gradually build up these lists and your phone will know how to deal with the call the next time it comes in.

11.1.1. Switch Call Blocking on/off

When Call Blocking is set to On, it is On for whichever mode you're using (e.g Announce mode). If you turn Call Blocking Off, all calls will be allowed through, even if they are already on your blocked list

1. In idle mode, press <block>.
2. Call Blocking settings are PIN protected, so follow the instructions to set your PIN or enter your PIN and select **OK**.
3. **Call Blocking** is highlighted, press **Select** or **OK**.
4. **Blocking settings** is highlighted, press **Select** or **OK**.
5. Press <Left> or <Right> to switch Call Blocking on/off, then press **Save**.

11.1.2. Personalize your announce message

You can personalize the Call Blocking greeting, by adding your name to the Announce message.

1. In idle mode, press <block>.
2. Follow the instructions to set your PIN or enter your PIN and select **OK**.
3. **Call Blocking** is highlighted, press **Select** or **OK**.
4. Scroll to **Announce msg**, press **Select** or **OK**.
5. Press **Select** or **OK**, on Record name and follow the voice prompt and press **Save**.
The recording will play back, if you're happy with it, press **OK**.

11.1.3. How do you accept, block or send a call to the answer phone?

1. Call Blocking answers a call for you and asks the caller to say ("announce") who they are.
2. Your phone then rings you with the Announced call on the display and announces the caller's name when you pick up the phone. (e.g. "You have a call from Mark").
3. You now have the following choices:
 - To accept the call, press 1
 - To always accept their calls, press 2
 - To block their calls, press 3 or press <block>
 - To send this call to the answer phone, press 4
 - Or to ignore the call, just hang up (this call will then be sent straight to the answer phone)

When a blocked call is received, **Blocked** will be displayed silently.

11.1.4. The Block button <block>

The block call button can be used in three ways:

1. In idle mode

Press <block> as a shortcut to the Call Control menu.

2. Incoming call

When you have an incoming call, the handset display will show '**Announced call**'. When you pick up the handset, you'll hear the caller announcement so you can decide whether to take the call.

If you don't want to take the call, press <block> on the handset and the caller will be advised that their call is not accepted, and the call will be disconnected.

The number will be blocked and added to the blocked calls list if Caller number is displayed.
If the number calls again, the caller will hear, “**Callers to this number are being screened by Call Blocking, the person you are calling is not accepting your call. Please hang up**”.

3. During a call

If you have already answered the call and you want to block the number, press <block>.
If the number is displayed you have the option to select **Yes, End call and block number?** will be displayed and the number will be added to the blocked numbers list and the call will end.
Or select **No** to go back to the caller.

Note: No PIN number is required when using the block call button when there is an incoming call or during a call.

11.1.5. How do I change the different Call Blocking modes?

You can change the default setting of Announce mode to Answer phone or Custom:

1. In idle mode, press <block>.
2. Follow the instructions to set your PIN or enter your PIN and select OK.
3. **Call Blocking** is highlighted, press **Select** or **OK**.
4. **Blocking settings** is highlighted, press **Select** or **OK**.
5. Scroll down using the <Calls> to Blocking mode and then use the <Left> or <Right> to select the one that you want to change (e.g. Personalize) and press **Save**.

11.1.6. Custom mode

Once you get used to your phone, you might decide to customize your settings depending on the call type. For example, you can allow unknown numbers but block private numbers and send withheld numbers to the answer phone.

Remember: settings will be the same as the last mode you selected, unless you save your own custom options.

Here's how to customize settings for certain types of call

1. In idle mode, press <block>.
2. Follow the instructions to set your PIN or enter your PIN and select OK.
3. **Call Blocking** is highlighted, press **Select** or **OK**.
4. **Blocking settings** is highlighted, press **Select** or **OK**.
5. Scroll down using the <Calls> to Blocking mode and then use the <Left> or <Right> to find **Custom**.
6. Press **Save** and scroll to find the type of call that you want to change the settings for.
You can change:
Blocked numbers / Allowed numbers / Withheld / Mobile numbers / Unavailable / All other numbers.
And for each of these, you have the choice to: Block / Ans.phone / Allow / Announce.
7. Select **Save**.

11.1.7. What happens when you allow a number (caller)

Any numbers in your phone's Contacts are automatically allowed to come straight through to you to answer.

- When you get an allowed call, you'll see the caller's number (if available) with the call type below it on your phone's screen.
- If you don't answer a call from an allowed number, it will go through to your answer phone (if it's on) or eventually it will hang up if unanswered.

Remember: if you've allowed a contact, all the numbers in the same contact will also be allowed.

11.1.8. What happens to my VIP numbers?

These are always allowed to come through to you.

11.1.9. What happens when you block a number (caller)?

You can block a whole number or part of it (e.g. you can block by area codes).

- A caller calling from a blocked number will hear a message telling them that their call has been blocked.

- You'll see the caller's number (if available) in the Calls list with "Call block" .

Remember: if you've blocked a contact, all the numbers in the same contact will also be blocked.

11.1.10. How to add numbers straight to your Blocked and Allow lists

Aside from adding numbers to your Block and Allow list as calls come through, you can also add numbers directly to the lists via your Call Control menu.

11.1.11. To add a number to the block list

1. In idle mode, press <block>.
2. Follow the instructions to set your PIN or enter your PIN and select **OK**.
3. **Call Blocking** is highlighted, press **Select** or **OK**.
4. Scroll down using <Calls> to **Block numbers** and press **Select** or **OK**.
5. **Add number** is highlighted, press **Select** or **OK**.
6. Enter the telephone number you want to block and press **Save**.

11.1.12. To block numbers by area code

You can also block numbers by area code. This will mean that any calls beginning with that code will be blocked.

1. Follow the instructions above from 1 to 3 and then:
2. Scroll down using <Calls> to **Area codes**, press **Select** or **OK**.
3. On first use, you will see "**No area codes stored. Add code?**" Select **Yes**.
4. Add the area code (e.g. 01473) and press **Save**.

11.1.13. To add a number to the allow list or to unblock a number

1. Follow the instructions above from 1 to 3 and then:
2. Scroll down using <Calls> to **Allow numbers** and press **Select** or **OK**.
3. **Add number** is highlighted, press **Select** or **OK** .
4. Enter the telephone number you want to allow and press **Save**.

11.1.14. Deleting your blocked and allowed lists

When in the Block and Allow number menu, you also have the choice to delete the whole list.

11.2. Do not disturb

1. In idle mode, press <block>.
2. Follow the instructions to set your PIN or enter your PIN and select **OK**.
3. Scroll down using <Calls>.
4. **Do Not Disturb** is highlighted, press **Select**.
5. Press <Left> or <Right> to select **On**, **Off** or **Timed**.
6. If you select **Timed** you need to select the on and off times you want, press <Calls> and enter the on time, then <Calls> again and enter the off time.
7. Press <Calls> to highlight whether you want VIP calls to be **Allowed** or **Barred** using <Left> or <Right>, then press **Save**. The chosen setting will be displayed and you will hear a confirmation tone.

11.3. Assign VIP status to a contact

1. In idle mode, press <block>.
2. Enter the access PIN and select **OK**.
3. Press <Calls> to highlight **VIP list** and press **Select** or **OK**.
4. Read the prompt and select **Info**, read the message and select **Yes** at the end. Your contacts list will be displayed.
5. To assign contacts as VIP, highlight the contact and press **OK**. Select additional contacts if required by repeating above.
6. Select **Options**. **Add selected** will be highlighted, press **OK** and the selected entries will be added to your VIP list.

If you've already added contacts to your VIP's, the list will be displayed when you enter the VIP list menu. You can then select **Options to add VIPs, remove VIPs or assign a VIP ringtone.**

Press <Calls> to select 1 of items, press **Select** or **OK**.

12. Answering Machine

The answering machine can record and store up to 50 minutes. Each message can be up to 3 minutes in length depending on the message length set.

If you receive a call from a number you have stored in your Blocked calls list, and Call Blocking is switched on, the caller will not be able to leave an answer phone message.

12.1 Turn on/off the answering machine

12.1.1. Answer on/off through handset

1. Select **Menu, Answer Phone** is displayed, press **Select**.
2. Press <Calls> until **Answer mode** is highlighted, press **Select**.
3. Press <Left> or <Right> to select **On** or **Off**
4. Scroll down to set the answer mode.
5. Press<Left> or <Right> to highlight **Ans. & Rec** or **Answer only** and then select **Save**. **Answer mode saved** will be displayed and the current answer mode will be announced.

12.1.2. Auto On/off answering machine

1. Select **Menu, Answer Phone** is displayed, press **Select**.
2. Press <Calls> until **Settings** is highlighted, press **Select**.
3. Press <Calls> until **Auto on/off** is highlighted, press **Select**.
4. Press <Left> or <Right> to select **Off, Once once Daily, Mon~Fri, Sat, Sun.**
5. Scroll down to set On time (HH:MM).
6. Scroll down to set Off time (HH:MM).
7. Press **Save** to confirm.

12.1.3. Answer on/off through base

Press <ANS ON/OFF> key on the base to turn the answering machine on or off.

When the answering machine is turned on, it announces, **Answer phone on.**

When the answering machine is turned off, it announces, **Answer phone off.**

12.2. Outgoing messages

There are two pre-recorded male and female outgoing messages to choose from, one that allows callers to leave a message (**Answer & Record**) and one that simply answers the call (**Answer Only**) or you can record your own.

12.2.1. Record your own outgoing message

1. Select **Menu, Answer Phone** is displayed, press **Select**.
2. Press <Calls> until **Outgoing msg** is highlighted, press **Select**.
3. Press <Up> or <Calls> to highlight the outgoing message mode you want: **Ans. & record** or **Answer only** and press **Select**.
4. **Record message** is highlighted, press **Select**.
5. Follow the voice prompt to record your message and select **Save** when you've finished.
6. Your message will be played back to you. Select **OK** if you're happy with it or you can delete it by selecting **Delete**.
- 7.

12.2.2. Play the current outgoing message

1. Follow the instructions above from 1 to 3 and then:
2. Press <Calls> to highlight **Play message** and press **Select** to hear the outgoing message.
3. You can delete it if you want to by selecting **Delete**.

12.2.3. Use the pre-recorded outgoing message

1. Follow the instructions above from 1 to 3 and then:
2. Press <Calls> to highlight **Use default msg** and press **Select**
3. Press <Left> or <Right> to choose **On**. Scroll down and then use <Left> or <Right> to choose either **Female** or **Male** in Message voice and select **Save**. **Saved** will be displayed.

12.3. Record a memo

1. Select **Menu**, **Answer Phone** is displayed, press **Select**.
2. Press <Calls> until **Record memo** is highlighted, press **Select**.
3. Follow the voice prompt to record your memo and select **Save** when you've finished.
4. Your memo will be played back to you. Select **OK** if you're happy with it or you can delete it by selecting **Delete**.

12.4. Ring delay

The Ring delay setting sets how many times the phone will ring before the answer machine takes the call. You can choose from 2–10 rings or Time saver.

1. Select **Menu**, **Answer Phone** is displayed, press **Select**.
2. Press <Calls> until **Settings** is highlighted, press **Select**.
3. **Ring delay** is displayed, press **Select**.
4. Press <Up> or <Calls> to highlight the outgoing message mode you want: **Ans. & record** or **Answer only** and press **Select**.
5. Use <Left> or <Right> to display the number of rings you want (2–10 rings or **Time saver**) and select **Save**. **Saved** will be displayed.

12.5. Set the maximum message length & message alert on/off

You can set the maximum length that an answer machine message can be: 1 minute, 2 minutes or 3 minutes, then set message alert on or off when new voice message is received.

1. Select **Menu**, **Answer Phone** is displayed, press **Select**.
2. Press <Calls> until **Settings** is highlighted, press **Select**.
3. Press <Calls> until **Ans. & record** is highlighted, press **Select**.
4. Press <Calls> to display **Max. msg length** and then press <Left> or <Right> to select the length you want
5. Press <Calls>, and then press <Left> or <Right> to select **On** or **Off** in **Message alert** and select **Save**. **Saved** will be displayed.

12.6. Call screening via the handset or the base

When call screening is turned on and the answer machine takes a call, you can listen to the caller leaving a message. You can then identify the caller and decide whether to take the call-in person.

12.6.1. Turn call screening on or off

1. Select **Menu**, **Answer Phone** is displayed, press **Select**.
2. Press <Calls> until **Settings** is highlighted, press **Select**.
3. Press <Calls> until **Call screening** is highlighted, press **Select**.
4. Press <Calls> to select either **handset** or **base**, then press **Select**.
5. Press <Left> or <Right> to select **On** or **Off** and select **Save**. **Saved** will be displayed.

To adjust the base call screening volume, go to the Call screening menu as above, choose **Base** and scroll through to find **Volume**.

Scroll left or right to choose between different volumes and press the Left option button to **Save**

12.6.2. Using call screening

When the phone rings, wait for the answer machine to take the call.

When the caller begins to leave a message, the display will show **Leaving a message**, underneath the caller number.

If you wish to listen to the message being recorded, press the left option key to select **Listen** or, if you wish to talk to the caller, press <Phone on> to take the call. Talking to the caller will stop the recording if it's started

12.7. Message playback

12.7.1. Using the handset

1. Press <Left> or <Right> to highlight the answer phone icon on the idle screen and press **OK**, or

- i. Select **Menu, Answer Phone** is displayed, press **Select**.
- ii. **View Messages** will be displayed, press **Select**.

2. A list of your answer phone messages will be displayed with the most recently received highlighted at the top.

3. Use <Up> or <Calls> to scroll through the list to highlight the message you wish to listen to and press **OK**.

4. If you have more than one message stored and want to listen to them all, select **Options. Play all** will be highlighted, press **Select**.

5. As each message is played through earpiece (or press <phone on> to play in speaker mode), the handset will display the calling number or the name if you have Caller Display and a name/number match and the time and date it was received. If you have any old (already listened to) messages these will be played after your new messages.

6. During playback you have the following options:

- i. <Up> or <Calls> to adjust the playback volume.
- ii. Key 1 or <Left> once to repeat the current message playing from the beginning.
- iii. Key 4 or <Left> twice within a second to skip back to the previous message.
- iv. Key 6 or <Right> once to skip forward to the next message.
- v. Key 3 or **Delete** to delete the current message playing.

At the end of playback, you will hear, "**End of messages**," and the same message will be displayed.

The "answer phone icon" on the idle screen will be re-numbered to take into account any deleted messages.

12.7.2. Using the base

i. Press <Play/Stop>. New messages are played first, and then followed by old (played) messages.

During playback: Press <Play/Stop> to stop playback. The base will return to idle.

- ii. Press <Delete> to delete the message being played.
- iii. Press <Forward> to skip forward to the start of the next message.
- iv. Press <Backward> to skip back to the start of the current message.
- v. Press <Backward> twice to skip back to the start of the previous message.
- vi. Press <Vol+>, <Vol-> to increase or decrease the playback volume level.

At the end of playback, the base will return to idle mode and messages will be renumbered to take into account any deleted messages.

12.8. Delete a message or delete all old (played) messages

1. Select **Menu, Answer Phone** is displayed, press **Select**.

2. **View Messages** will be displayed, press **Select**. A list of your answer phone messages will be displayed.

3. Select **Options** and scroll down to highlight either **Delete message** or **Delete all old msgs** and press **Select**.

4. A confirmation question will be displayed, select **Yes** to confirm deletion

Note: In idle mode, press <Delete>. The base will announce, “**To delete all old messages, press Delete**”, press <Delete> again within 3 seconds to delete all old messages. You will hear, “**All old messages deleted.**”

12.9. Save a number in the answer phone message list to your contacts

1. Select **Menu, Answer Phone** is displayed, press **Select**.
2. **View Messages** will be displayed, press **Select**. Press <up> or <calls> to highlight the number you want to save and select **Options**.
3. Scroll down to highlight **Save number** and press **Select**.
4. You now have two options:
 - i. To save this as a new contact, highlight **New contact** and press **Select**. Highlight the type of number, then press **Select**. Enter the contact name and select **Save**.
 - ii. To add to an existing contact, highlight **Add to contact** and press **Select**. Scroll to highlight the entry you want, and press **Select**. Highlight the number type where you want to save the number (Home, Work or Mobile) and press **Select**.

12.10. Remote access

With remote access you can operate your answer machine from any touch-tone telephone, even if you forget to turn on your answer machine before you go out. You need to set a remote access 4-digit PIN first and then you will need to turn remote access on if you want to use this feature.

12.10.1. Set the remote access PIN for the first time (in case Call Control PIN is not yet set)

1. Select **Menu, Answer Phone** is displayed, press **Select**.
2. Press <Calls> until **Settings** is highlighted, press **Select**.
3. Press <Calls> to highlight **Remote access** and press **Select**.
4. Read the message prompt, press <Calls> to read it all, then select **Set PIN**.
5. Enter a 4-digit PIN of your choice and select **OK**.
6. Enter the 4-digit PIN again to confirm and select **OK**. The display will show **Access PIN saved**.

12.10.2. Change the remote access PIN

1. Repeat step 1 to 3 of Section 12.10.1.
2. Press <Calls> to highlight **Change PIN** and press **Select**. You will be reminded that the access PIN is used for both remote access and call control.
3. Enter your old 4-digit PIN and select **OK**.
4. Enter the new 4digit PIN, select **OK**, then enter the new PIN again and select **OK**. The display will show **New Access PIN saved**.

12.10.3. Turn remote access on or off

1. Repeat step 1 to 3 of Section 12.10.1.
2. **On/Off** is displayed, press **Select**.
3. Press <Left> or <Right> to display **On** or **Off** and select **Save**. **Saved** will be displayed.

12.10.4. Operating you answer machine remotely

1. Dial your phone number.
2. When you hear your outgoing message, press * and enter your 4-digit remote access PIN.
3. Follow the voice prompts as below:
 - 1 To replay the current message
 - 2 To play all messages

- 3 To delete during messages
- 4 To skip back during messages
- 5 To set Answer machine OFF, or ON
- 6 To skip forward during messages
- 8 To play your outgoing message
- 9 To record a new outgoing message
- # To set to **Answer Only**, or **Answer & Record**
- 0 To hear the main menu options

13. Technical Specifications

Free Field Range	Up to 300 meters*
Indoor Range	Up to 50 meters*
Handset Battery Life (average values)	18 hours talk time** 300 hours standby**
Number of Handsets	Up to 4
Intercom Mode	Yes
Three-Way Conference (1 outside correspondent + 2 internal correspondents)	Yes
Electrical Connection/Base Mains Adaptor/Charger	Base main adaptor & Charger adaptor: Model No.: AT-337E-060045 / 1-CHEUA451-081 Input: 100-240 V/50-60 Hz/0.15 A Output: 6 V DC/450 mA, 2.7W Only use the adaptors supplied with telephone. Single-phase AC, excluding IT install defined by the EN62368-1 standard. Caution: The network voltage is classified as hazard by the criteria of this standard.
Telephone Connection	Appliance designed for connection to a TNV3 class (telecommunications network voltage) analogue telephone line as defined by the EN62368-1 standard.
Batteries	2pcs of AAA NiMH batteries – 2.4 V – 750 mA Only use the batteries supplied with the telephone. Use any other type of battery presents a risk of explosion. Used batteries must be disposed of in compliance with current environmental protection regulations.
Operating Temperature	From 5°C to 40°C

* Values may vary according to environment.

** Depending on initial battery charge.

14. Troubleshooting

If you have difficulty with your phone, please try the suggestions listed below.

As a general rule, if a problem occurs, remove the batteries from all the handsets in your installation for about 1 minute, then disconnect and reconnect the power supply to the base and reinstall the handset batteries.

Phone does not work

- Make sure you installed the battery correctly.
- Check that the mains power is correctly connected.

No dial tone

- Is the telephone cord plugged into the phone socket?
- Check that the mains power is switched on.
- Only use the telephone cord supplied with the phone.
- The telephone line cord might be malfunctioning. Install a new telephone line cord.
- Move the handset closer to the telephone base. It might be out of range.
- Disconnect the telephone and connect a different telephone. If there is no dial tone on this telephone, the problem is in your wiring or local service. Contact your local telephone company.

Cannot dial out or receive calls or “Line cord error” is displayed on the screen

- Check that the mains power is correctly connected.
- The battery may need recharging.
- Has there been a power cut? If so, place the handset back on the base for 10 seconds and try again. If it still does not work disconnect the battery and mains power for 10 minutes, then reconnect and try again.
- If you are connected to a PABX, check whether you need to dial an access code or set prefix in PBX Code menu.
- Only use the telephone cord supplied with the phone.
- The telephone line cord might be malfunctioning. Install a new telephone line cord.
- Check your Call Blocking settings.

Handset does not ring

- The ringer volume may be switched off.
- Check that the mains power is correctly connected.
- Make sure the handset is registered to the base.

No display

- The battery may be flat, dead or incorrectly inserted.
- Recharge or replace the battery

Handset displays “Searching”

- Is the handset registered correctly to the base?
- Check that the mains power is correctly connected.
- Check that the handset is within range of the base.
- Is the battery low? Place the handset on the base/charger to recharge.

You hear the busy tone when you press <phone on>key

- Make sure the handset is in range of the base.
- Another handset registered to your telephone base may be on the line.

Answering machine does not record any messages

- Make sure the answering machine is switched on.
- The memory may be full, please delete some old messages to free up space.
- Check your Call Blocking settings.

Cannot access your messages from another phone

- Have you changed the remote access security PIN code?
- Make sure you are calling from a touch-tone telephone. When dialing a number, there should be tones.
- The answering machine might not detect the remote access code when your outgoing message is playing. Wait until the outgoing message is over before entering the code.
- There might be interference on the telephone line you are using. Press the dial pad keys firmly when dialing.

Buzzing noise on my phone or on other electrical equipment nearby

- Sometimes your phone can interfere with other electrical equipment if it is placed too close. It is recommended that you place your phone at least one meter away from electrical appliances or metal obstructions to avoid any risk of interference.
- If you have an ADSL internet service ensure correct filters are installed to prevent interference.

15. Guarantee

16. Safety

In the event of an electrical hazard, the mains adapter acts as 230V power isolating device. It should therefore, as a precaution, be installed close to the appliance and be easily accessible. To disconnect the device from the primary power source, the mains adapter must be removed from the 230V AC/50 Hz socket.

If the mains adapter fails, it must be replaced by an identical model.

If not connected to the mains power or if there is a mains power failure, telephones that use cordless handsets will not work.

You will then be unable to make or receive calls in the event of an emergency.

Therefore, we recommend that you also keep a conventional telephone – one that doesn't require a power supply – as a backup.

! Do not use your telephone to notify a gas leak when standing in the vicinity of the leak.

It is recommended that you avoid using this device during electrical storms.

Do not attempt to open the batteries, as they contain chemical substances. In the event of leakage, avoid contact with the skin, eyes, nose and mouth. In the event of contact, rinse the affected part for about twenty minutes with running water and seek urgent medical attention. Clean the product with absorbent paper or a dry cloth and contact your reseller for replacement batteries.

17. ENVIRONMENT



This symbol means that your inoperative electronic appliance must be collected separately and not mixed with the household waste. The European Union has implemented a specific collection and recycling system for which producers are responsible.

This appliance has been designed and manufactured with high quality materials and components that can be recycled and reused. Electrical and electronic appliances are liable to contain parts that are necessary for the system to work properly but which can become a health and environmental hazard if they are not handled or disposed of in the proper way. Consequently, please do not throw out your inoperative appliance with the household waste.

If you are the owner of the appliance, you must deposit it at the appropriate local collection point or leave it with the vendor when buying a new appliance.

- If you are a professional user, please follow your supplier's instructions.

- If the appliance is rented to you or left in your care, please contact your service provider.

Keen to preserve the environment, ATLINKS has equipped this appliance with a switching power supply, offering better energy efficiency. The advantages include not only very low electricity consumption, but also a more compact format than the conventional power supply units used by the previous range.

The used batteries from your telephone (if it has batteries) must be disposed of in compliance with current environmental protection regulations. Comply with your local regulations.

Return your batteries to your reseller or dispose of them at an approved recycling centre.

Help us protect the environment in which we live!

18. Conformity



Menu Map

ATLINKS Europe
147 avenue Paul Dourmer
92500 REUIEL-MALMAISON
France

www.alcatel-home.com

Alcatel is a trademark of Nokia, used under license by ATLINKS.
Includes licensed Qaltel™ technology.
Qaltel™ is a trademark of Truecall Group Limited.

Alcatel F890 Voice
A/W No.: 10002279 Rev.0 (EN)
Printed in China