

- Montageanleitung
- Assembly instructions
- Notice de montage
- Montagehandleiding
- Návod na montáž
- Instrucțiune de montaj
- Navodila za namestitev
- Installationstruktioener

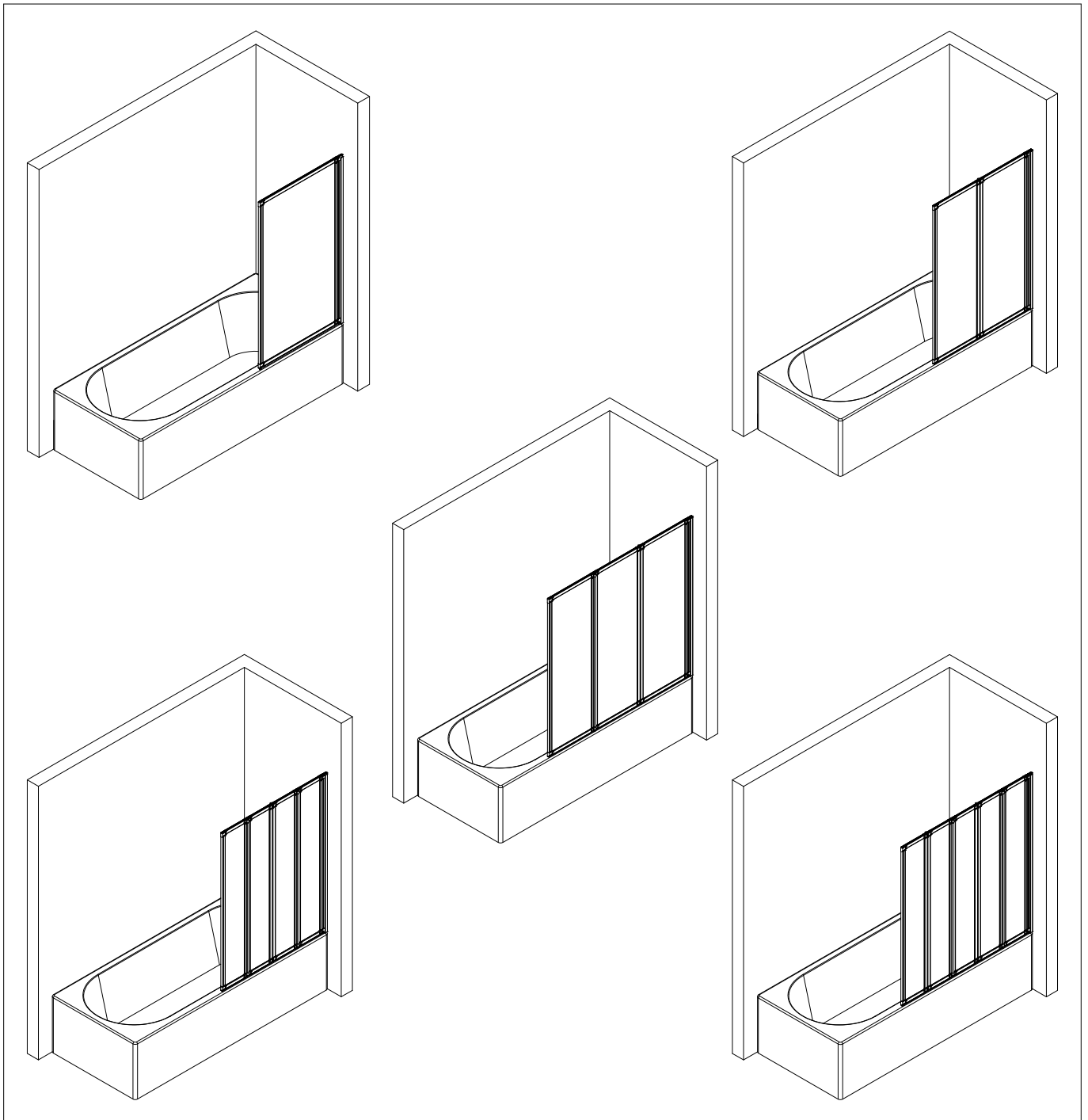

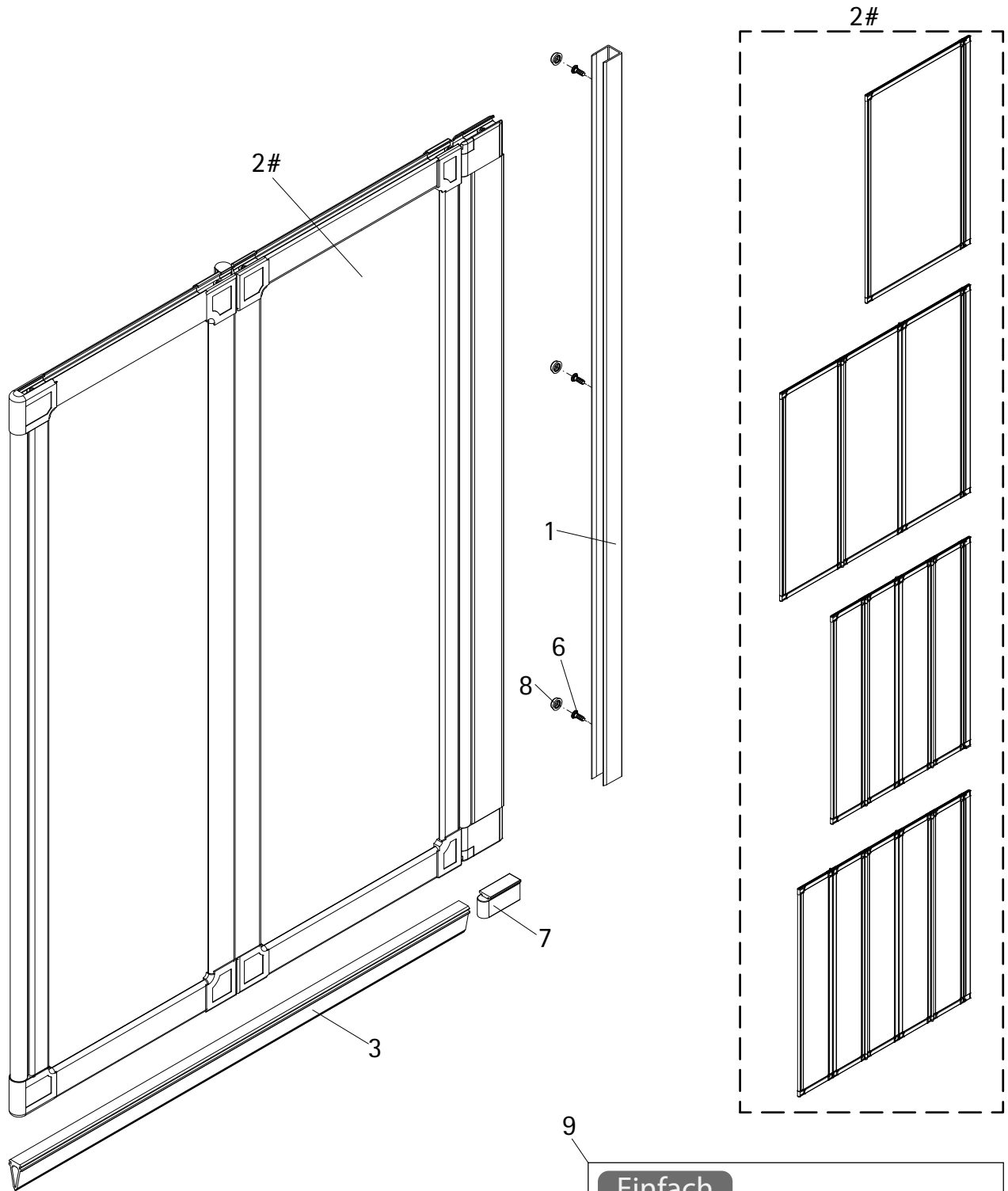

Pos.	Bezeichnung	Ersatzteil-Nr.	Preis
1	1x Wandanschlussprofil, eingeschoben	E60230-3	Stück 86,95 €
2#	1x Wannenaufsatz		
3	1x Dichtprofil horizontal	E100076-4	Stück 23,95 €
6*	3x Kappenschraube 3,5 x 9,5 mm		
7*	1x Endkappe für Dichtprofil		
8*	3x Abdeckkappe für Kappenschraube		
9	1x Klebeset komplett	E100496	Set 59,95 €
9.1	1x Reinigungstuch		
9.2	2x Kleber		
9.3	1x Spachtel für Kleber		
	* Schrauben und Abdeckkappenset # optional	E60200-2	16,95 €

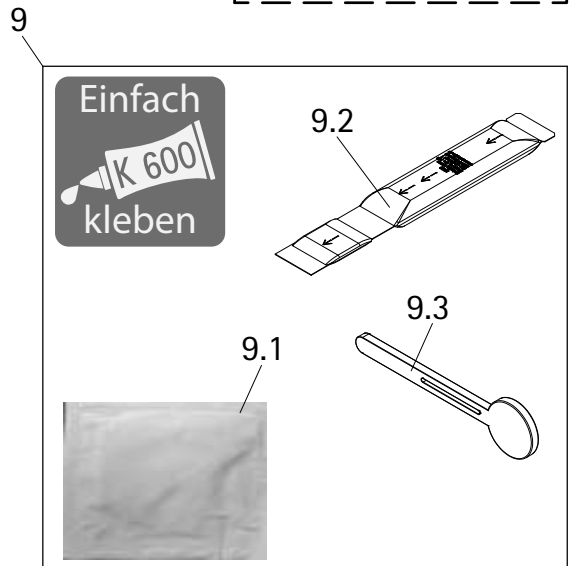

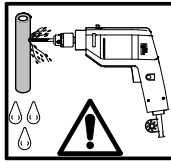
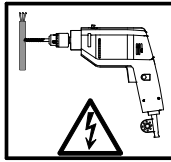
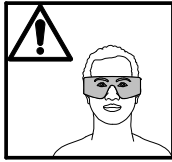
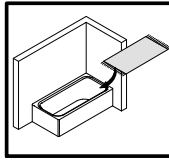
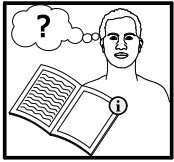

1

Profil kleben

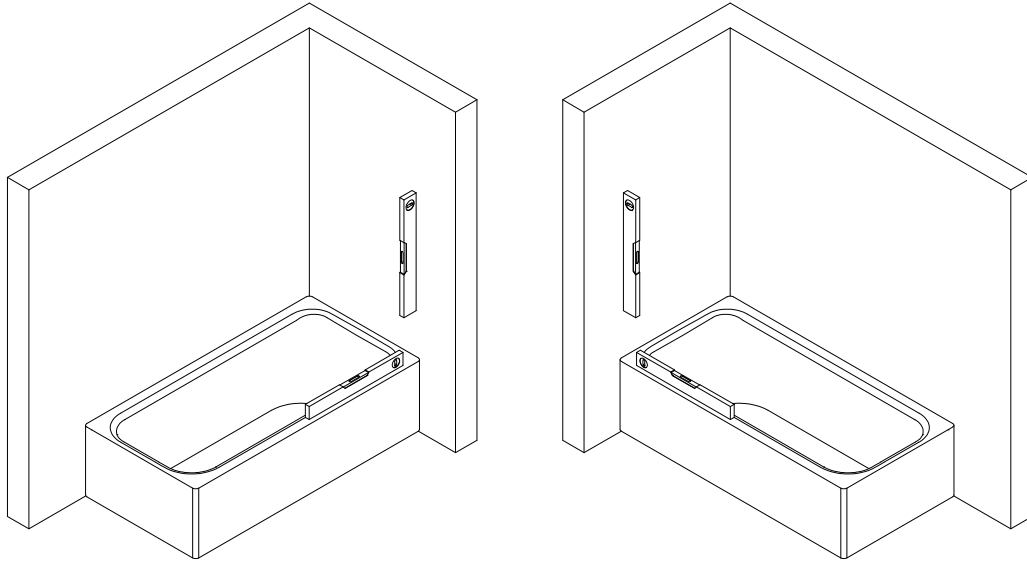

2



- Beipackzettel unbedingt beachten.
- Note: Read enclosed instruction leaflet carefully.
- Veuillez impérativement faire attention à la notice explicative.
- Let op: Iles de bijsluiter.

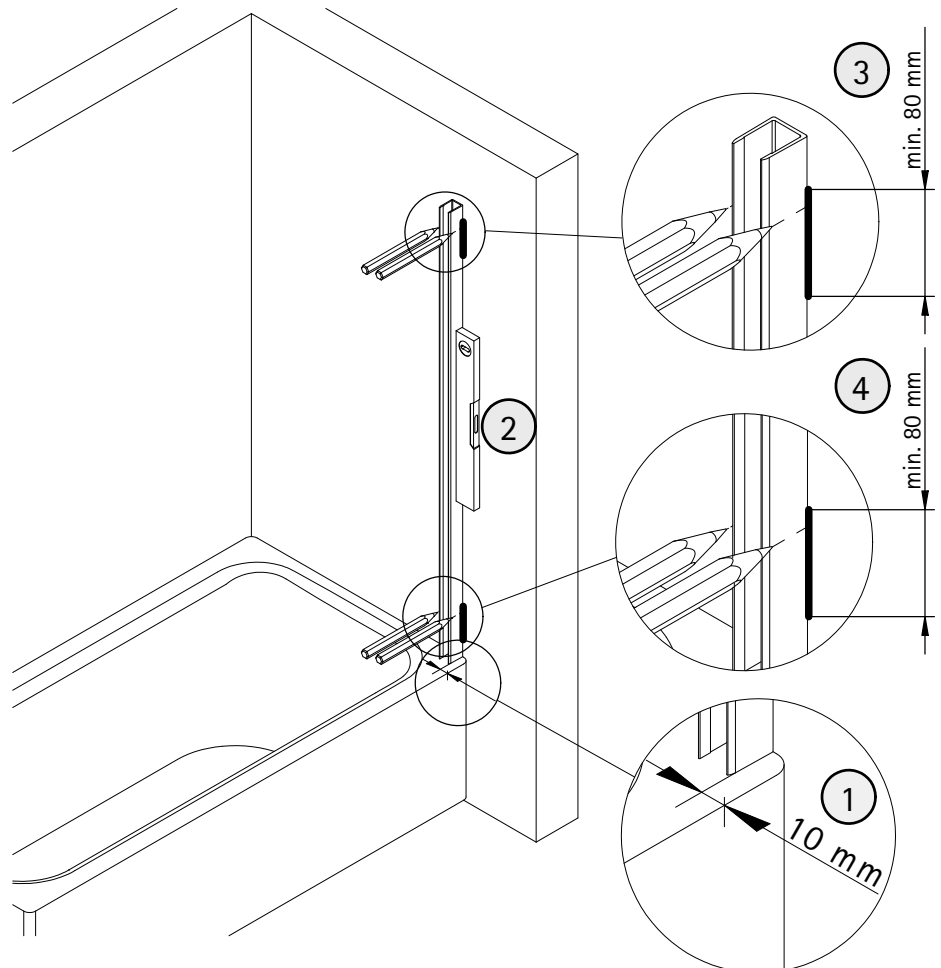

3

- Klebestreifen
- adhesive stripes
- ruban adhésif
- plakbanden

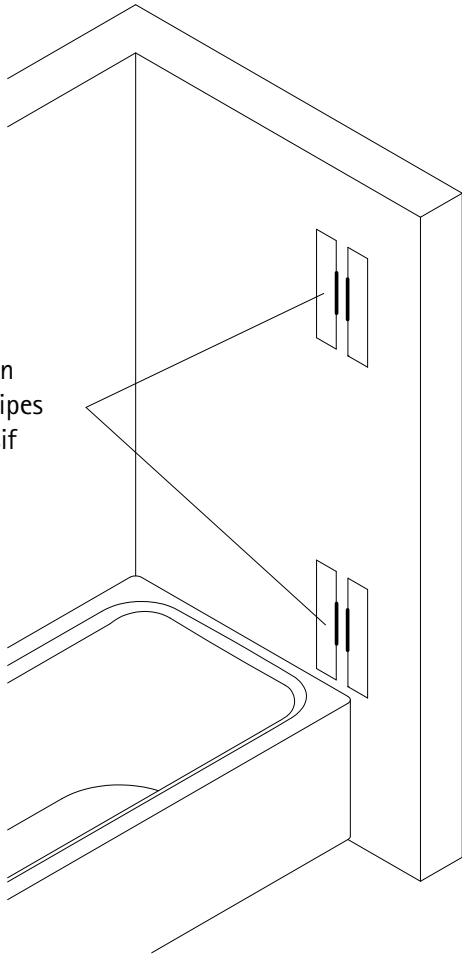

4

Pos. 9.1

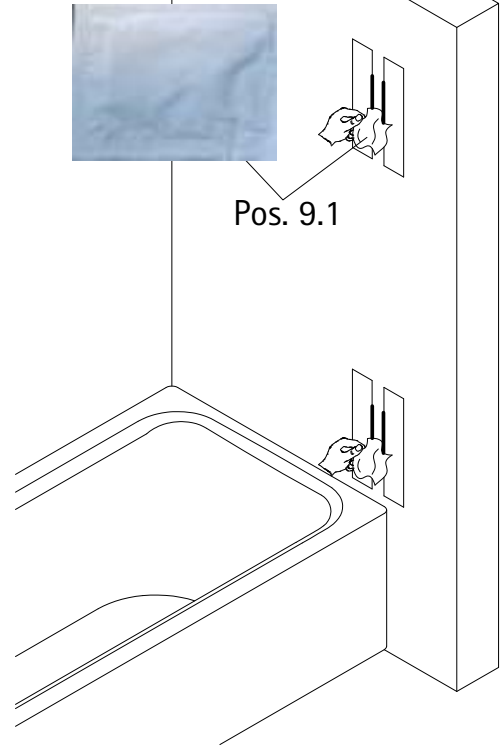

- Fläche reinigen
- Clean the surface
- Nettoyer la surface
- Oppervlak reinigen

5

*Anrührunterlage
stirring support
support pour mélanger
aanroer-ondergrond

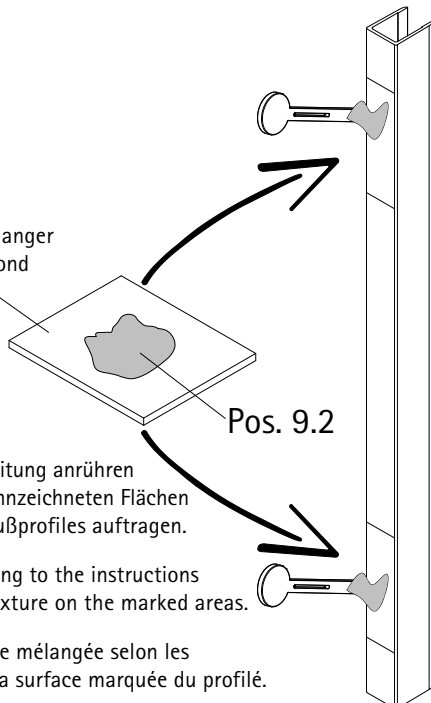

Pos. 9.2

- Kleber nach Anleitung anrühren und auf die gekennzeichneten Flächen des Wandanschlußprofils auftragen.
- Mix glue according to the instructions and apply the mixture on the marked areas.
- Appliquez la colle mélangée selon les instructions sur la surface marquée du profilé.
- Lijm volgens voorschrift omroeren en op de gemarke oppervlaktes van het wandaansluitprofiel aanbrengen.

* Nicht im Lieferumfang enthalten,
not included in delivery,
non fourni dans l'emballage,
niet bij levering inbegrepen,

6

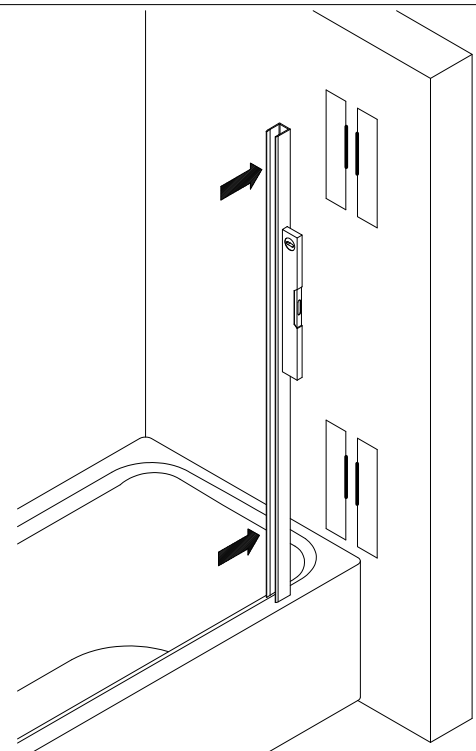

- Profil positionieren und andrücken.
- Position profile and press it onto the wall.
- Positionnez le profilé et appuyez le fortement contre le mur.
- Profiel plaatsen en aandrukken.

7

5 Std.

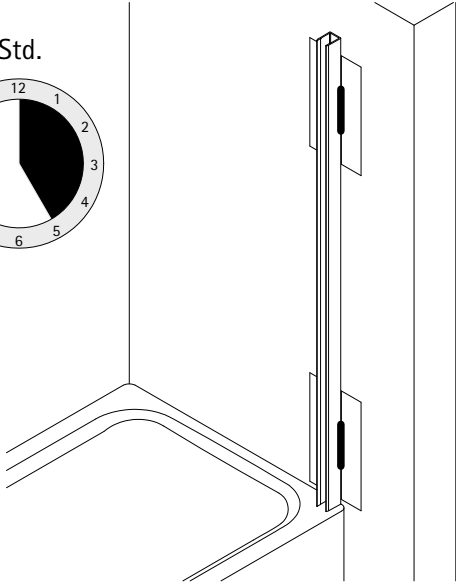
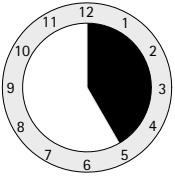

- Nach ca. 5 Stunden kann die Montage der Badewannenfaltwand begonnen werden.
- After approx. 5 hours the bath screen can be installed.
- Après env. 5 heures le montage du pare-baignoire peut démarrer.
- Na 5 uur kan met de montage van de badwand worden gestart.

8

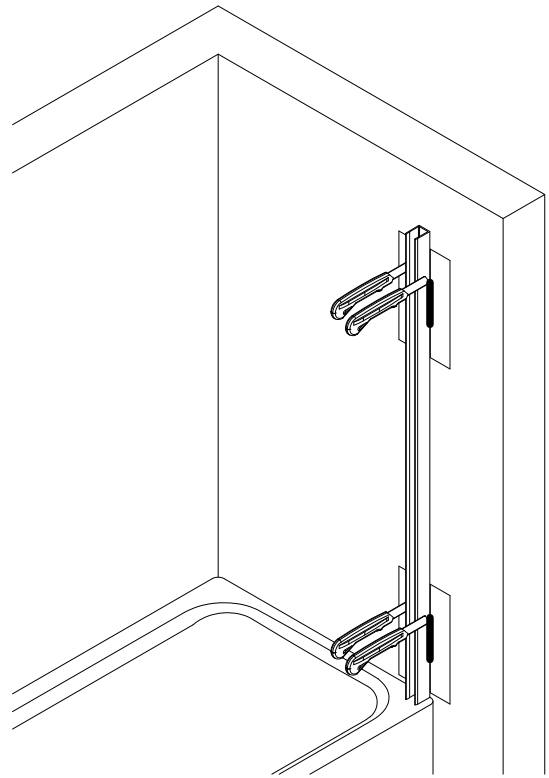

- Überstehenden Kleber entfernen.
- Remove overlaying glue.
- Enleverz le surplus de la colle.
- Restlijm verwijderen.

9

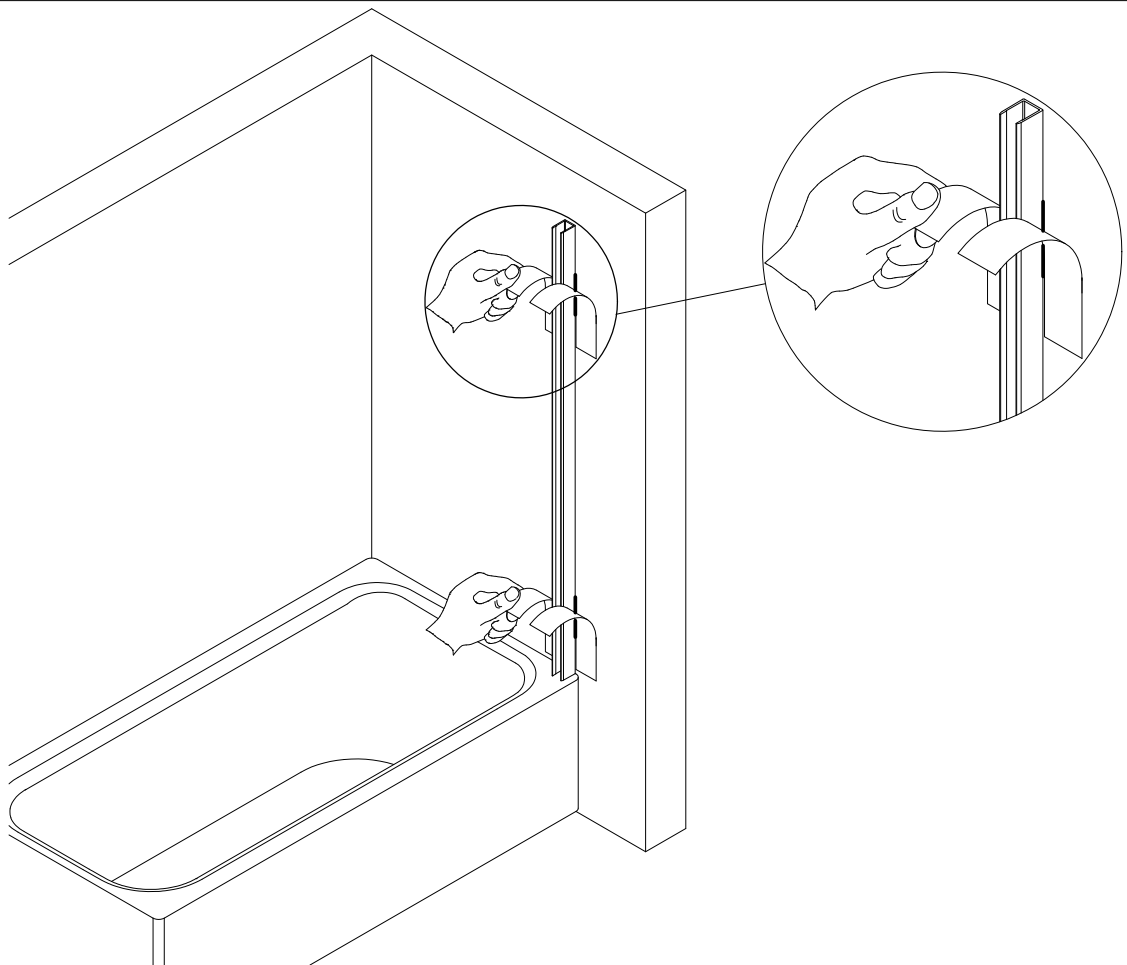

10

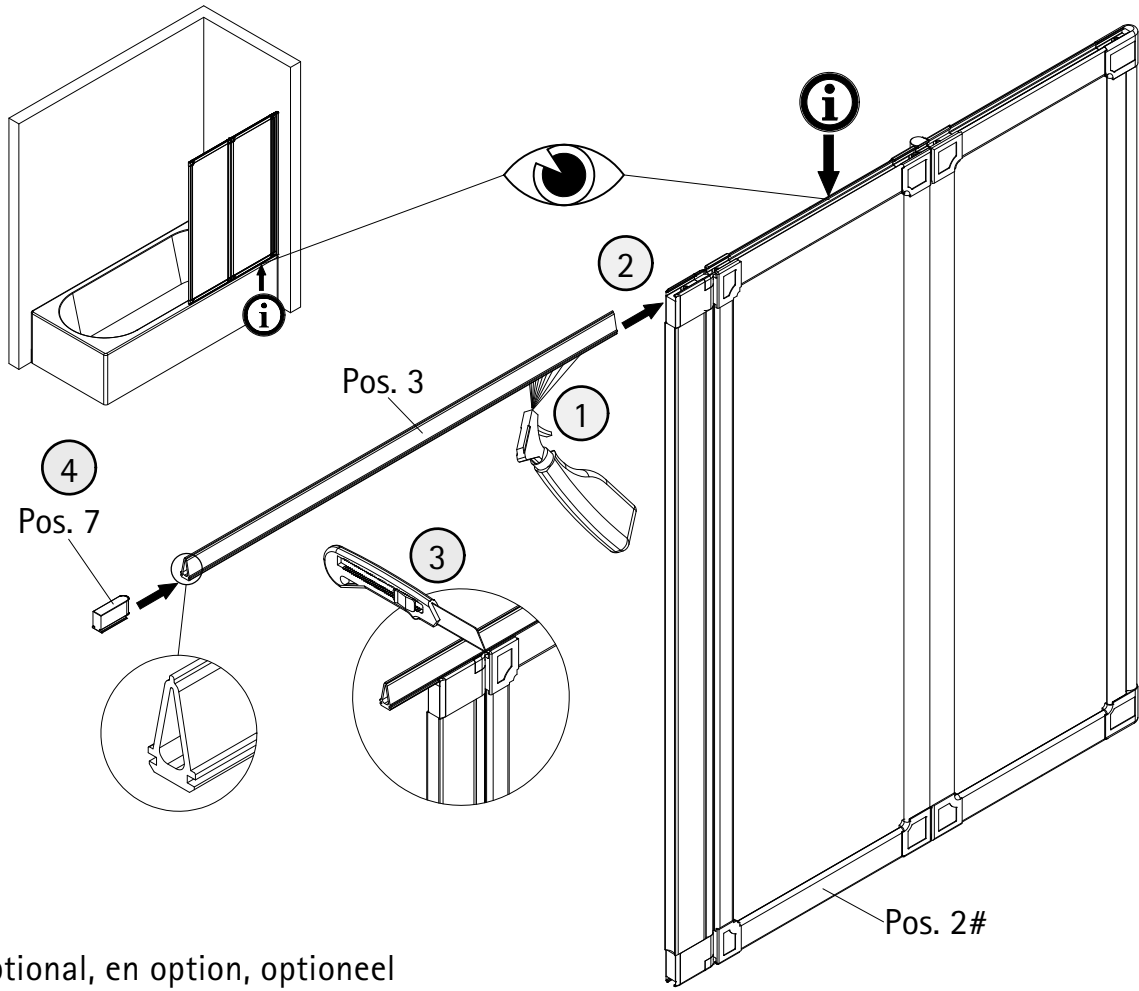

11

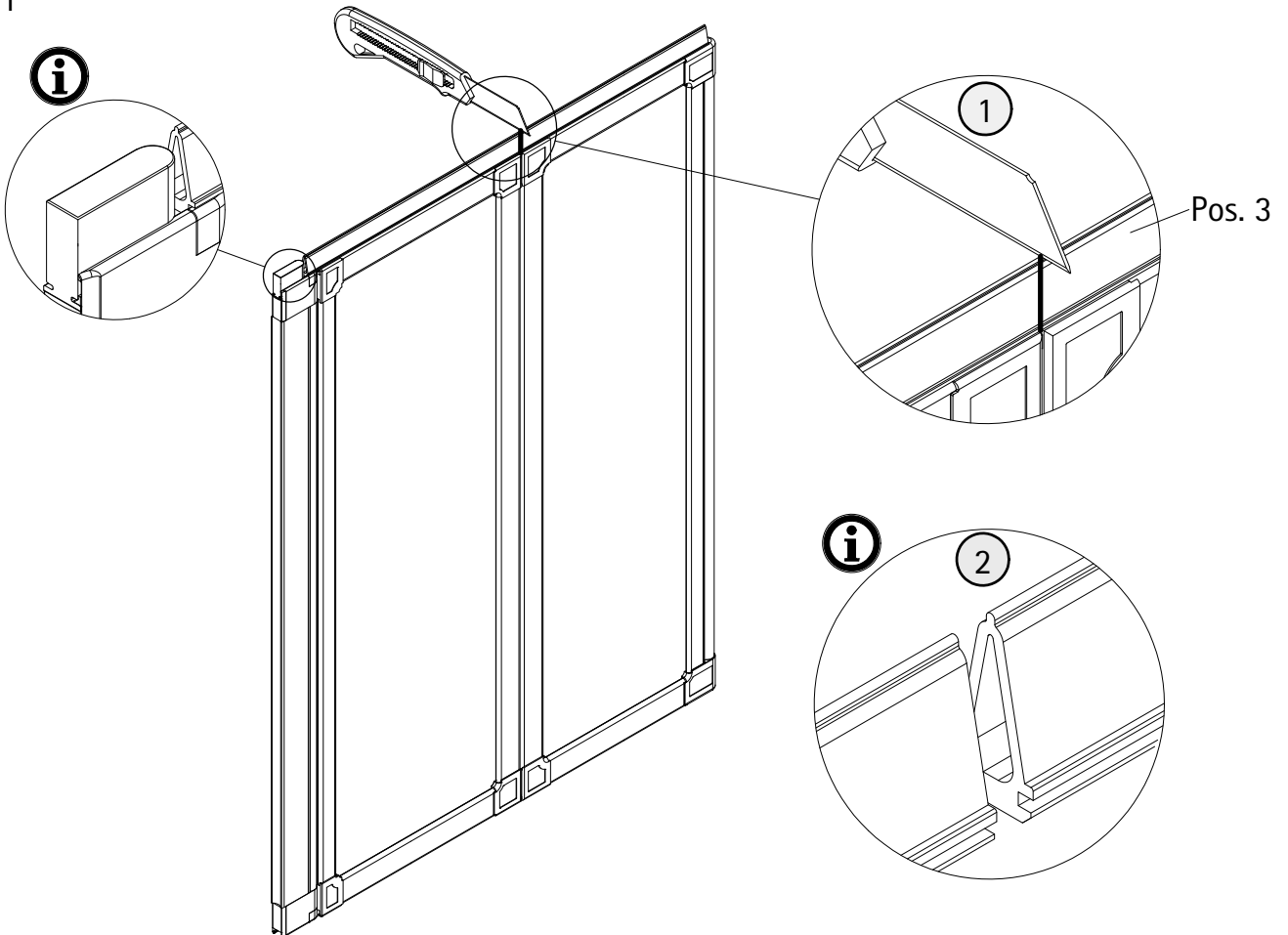

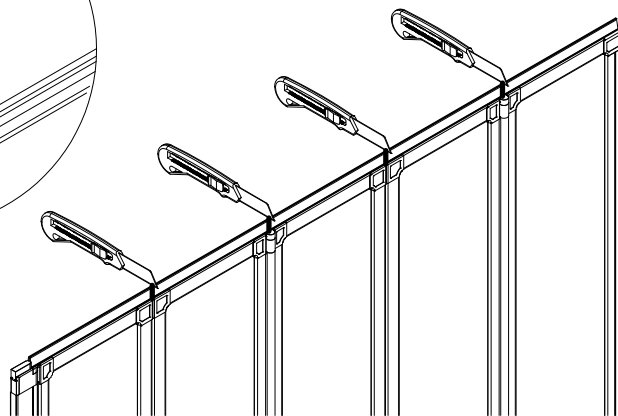
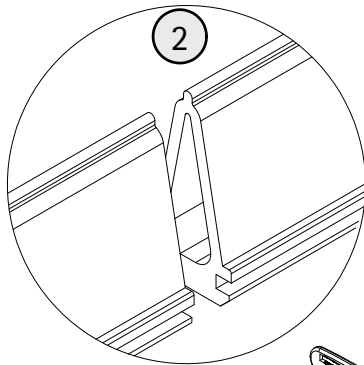
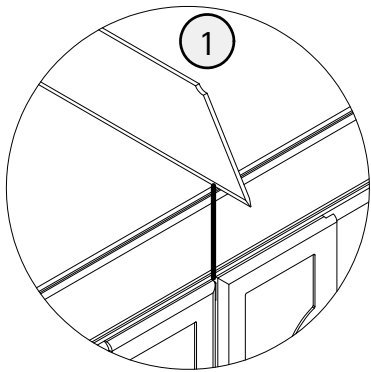
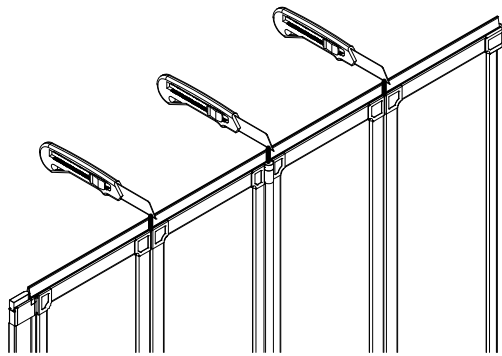
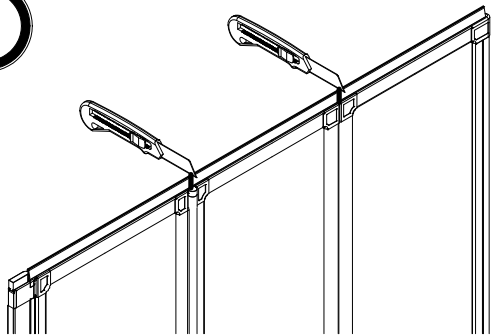

12

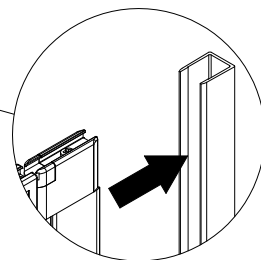
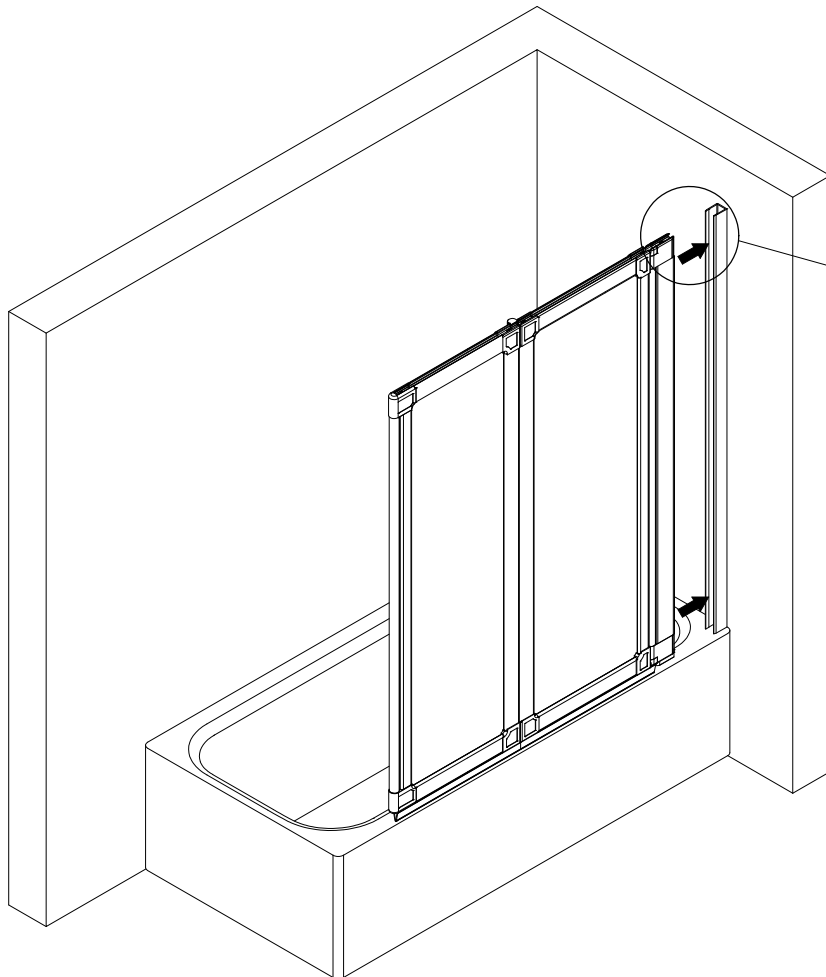

13

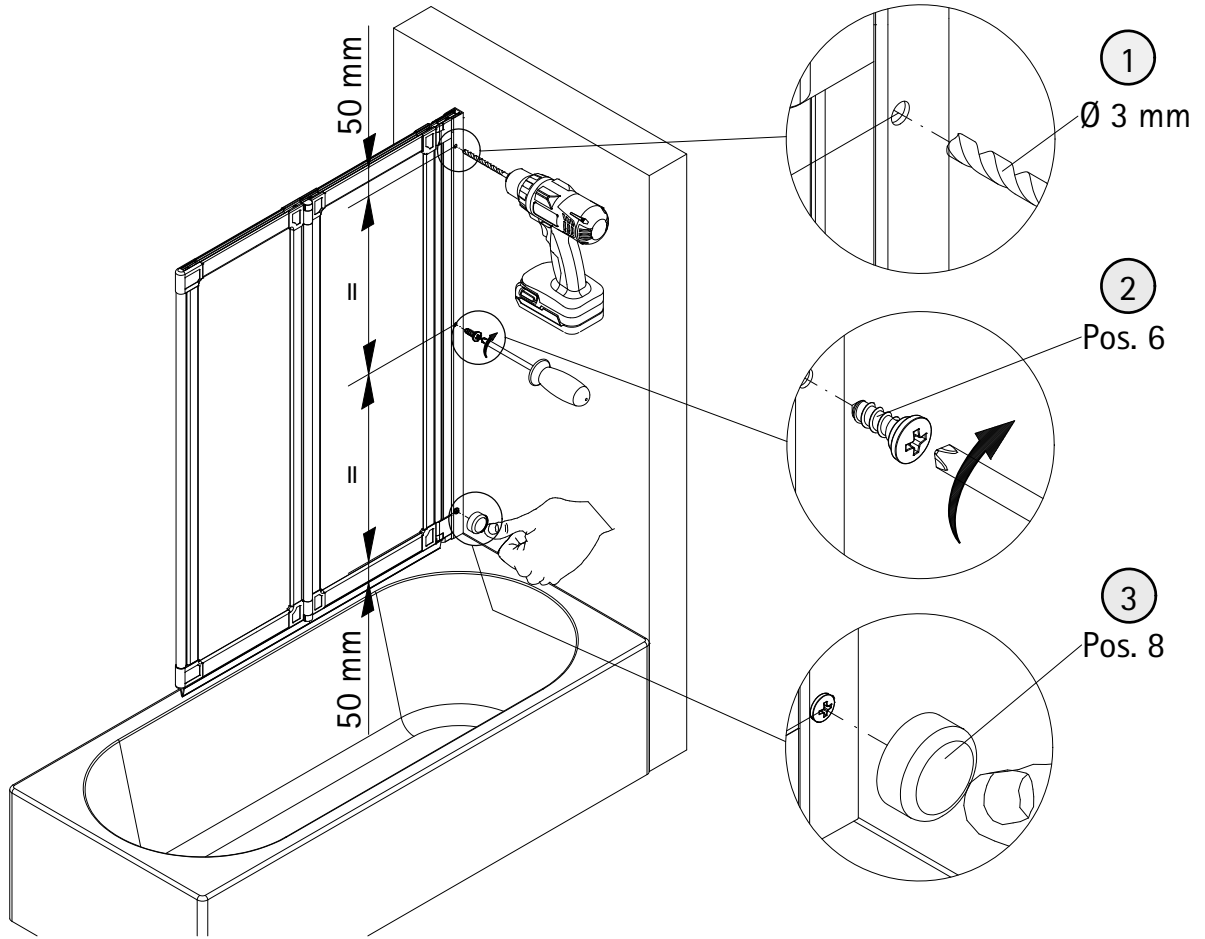

14

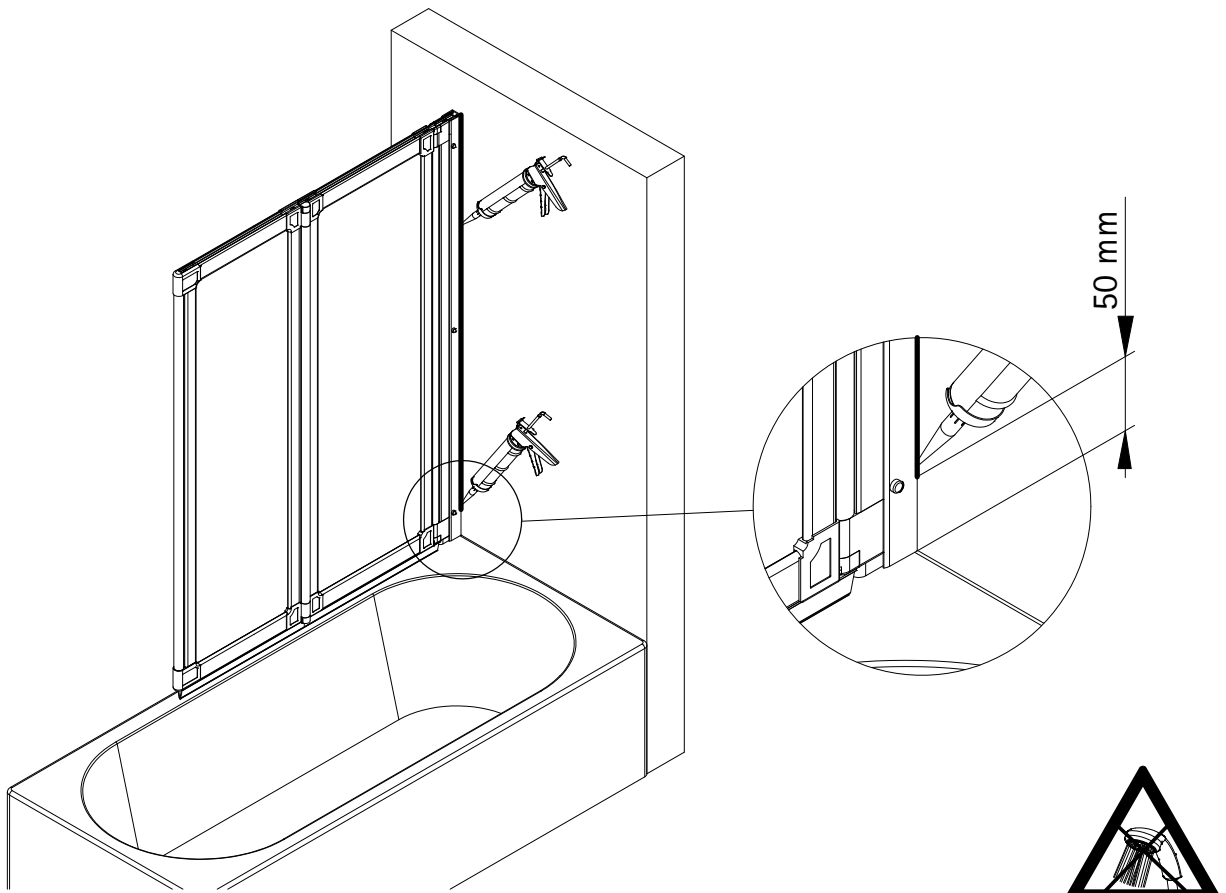

15

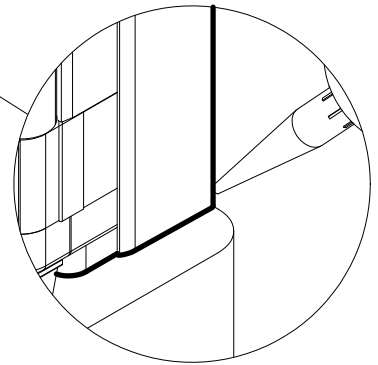
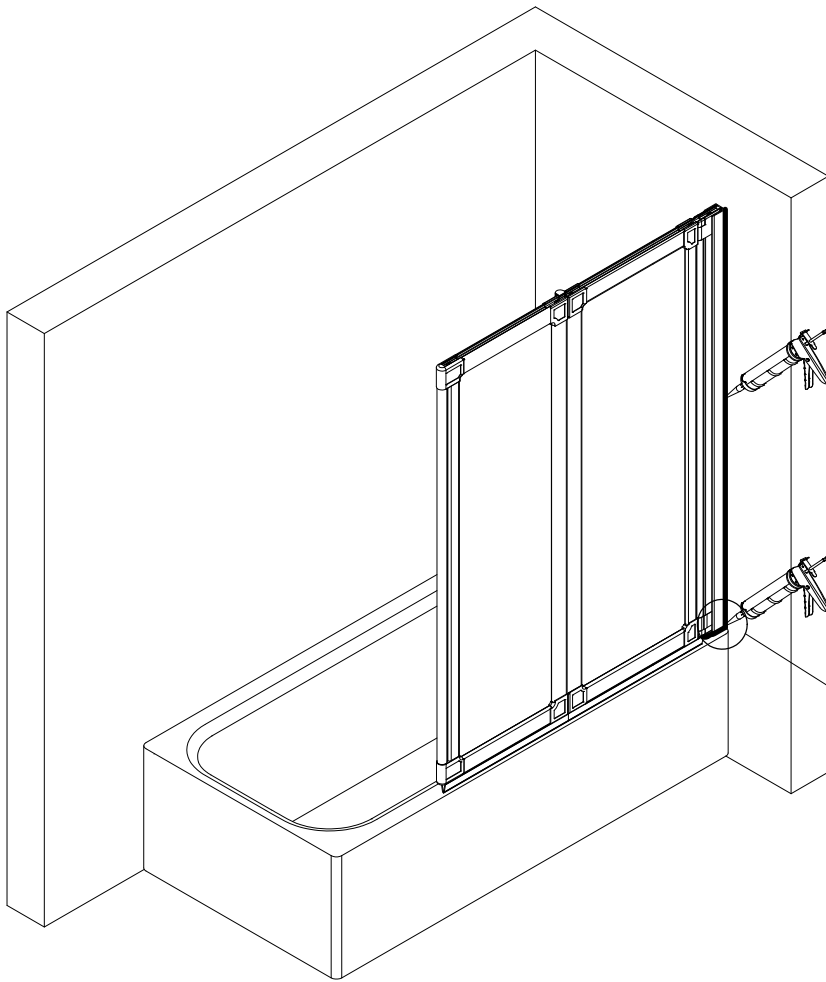

1557-2

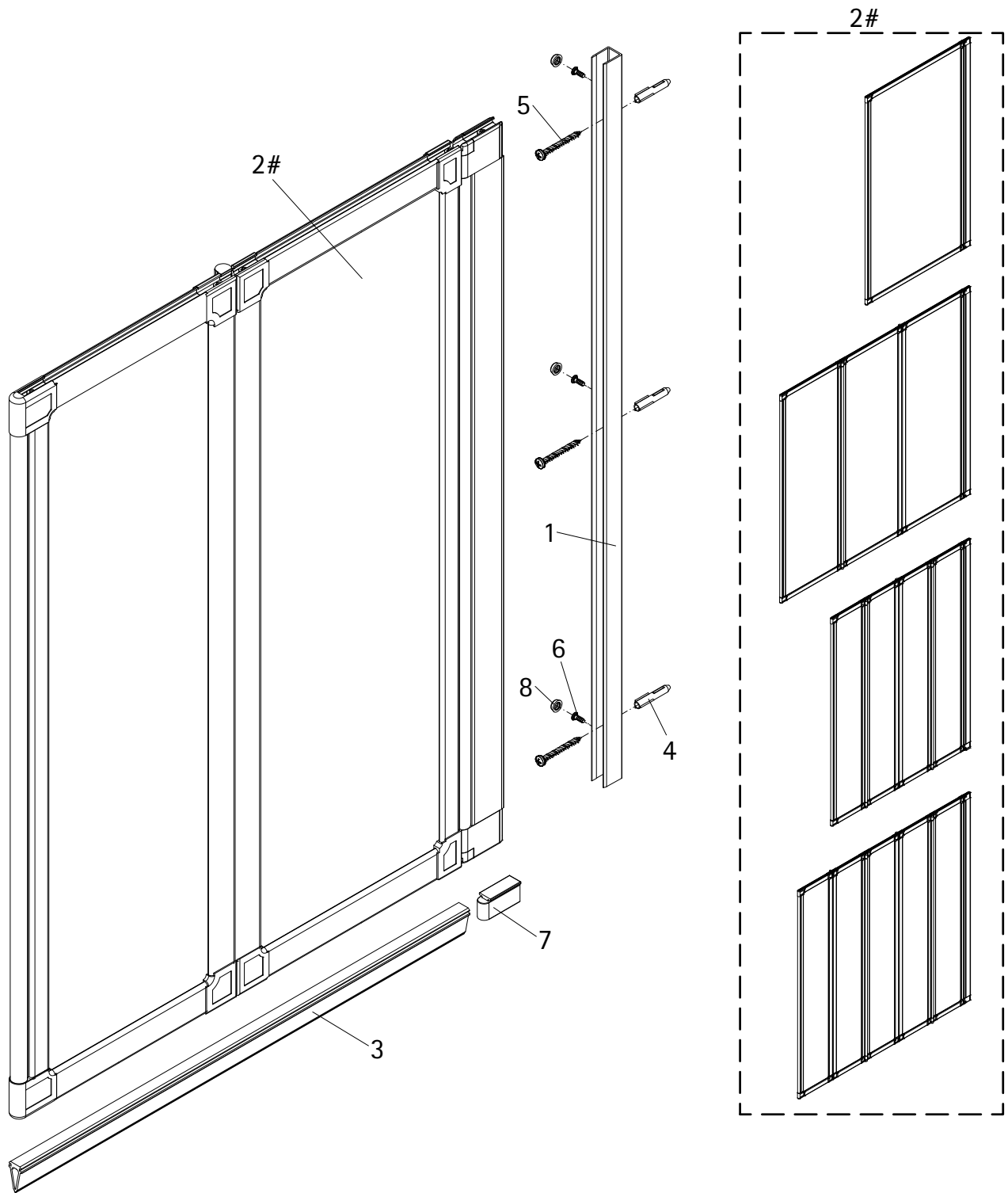

Pos.	Bezeichnung	Ersatzteil-Nr.	Preis
1	1x Wandanschlussprofil	E60230-3	Stück 86,95 €
2#	1x Wannenaufsatz		
3	1x Dichtprofil horizontal	E100076-4	Stück 23,95 €
4*	3x Dübel S6		
5*	3x Linsen-Blechschaube 4,2 x 45 mm		
6*	3x Kappenschraube 3,5 x 9,5 mm		
7*	1x Endkappe für Dichtprofil		
8*	3x Abdeckkappe für Kappenschraube		
	* Schrauben und Abdeckkappenset # optional	E60200-2	16,95 €

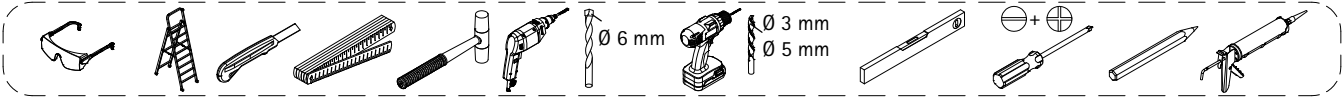
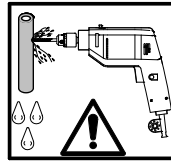
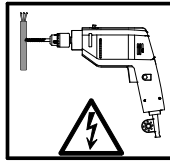
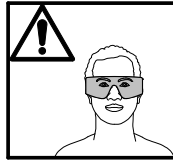
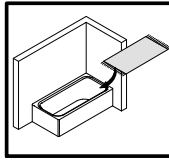
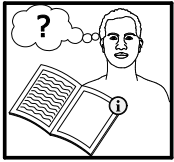

1

Profil bohren

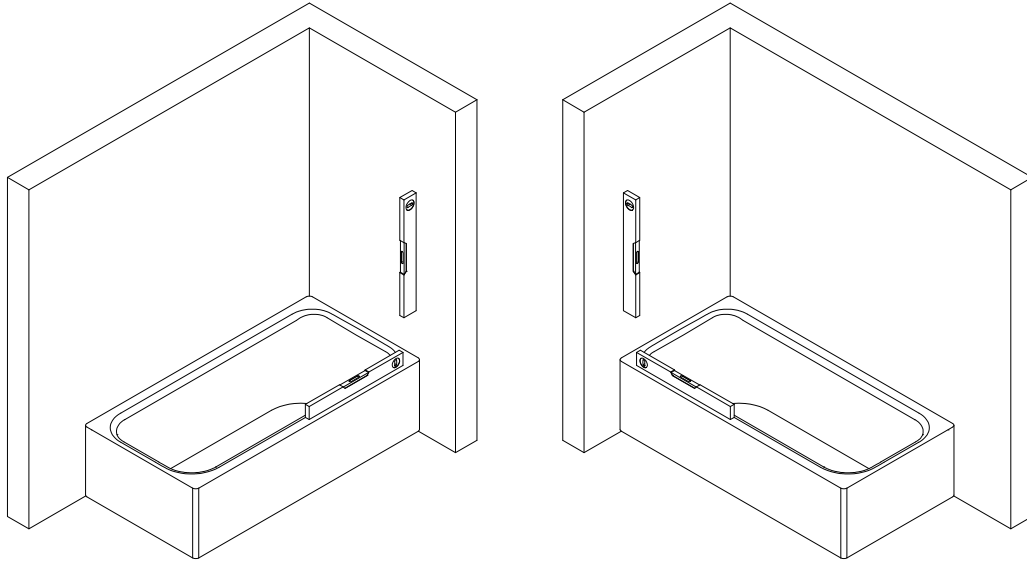

2

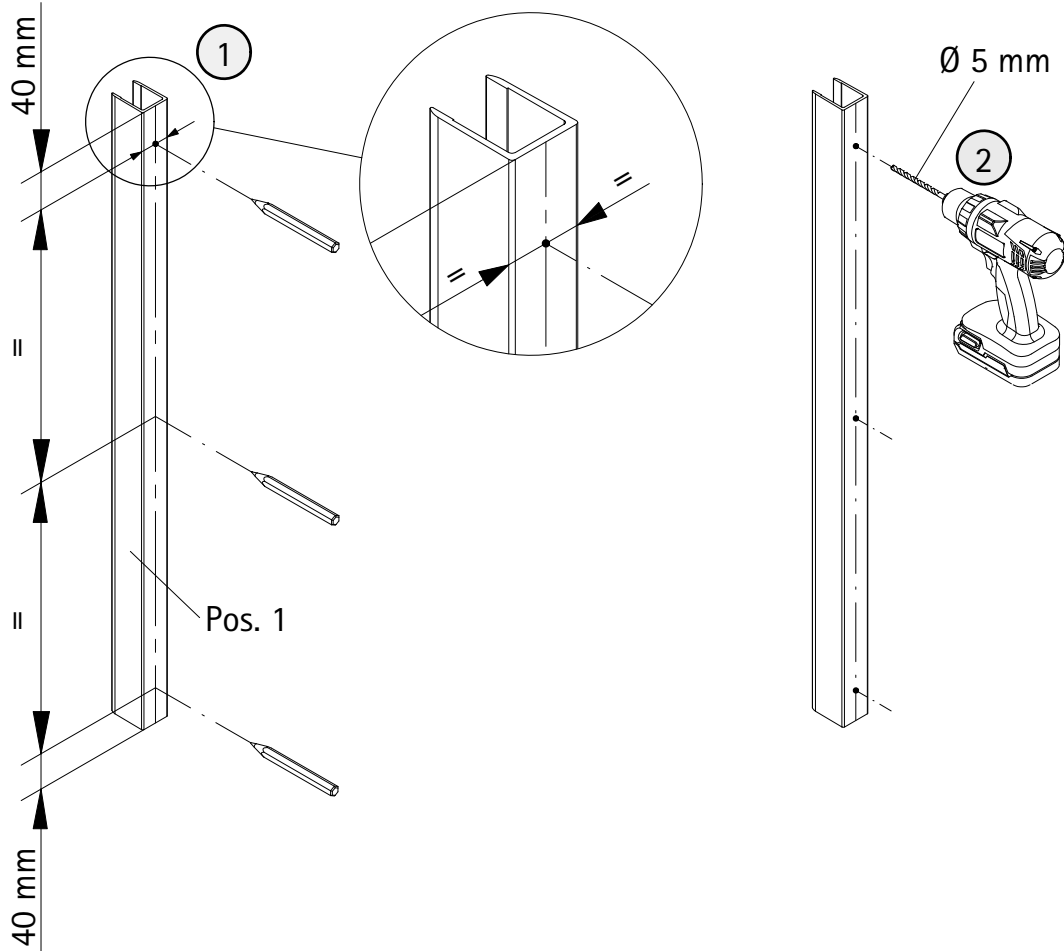

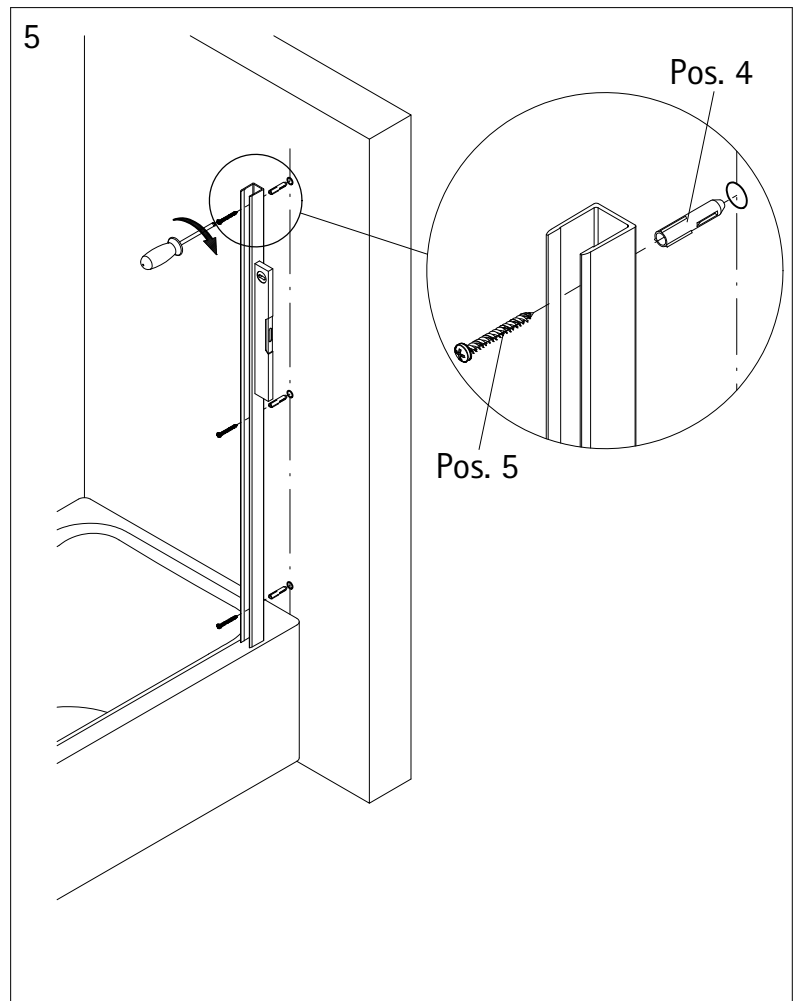
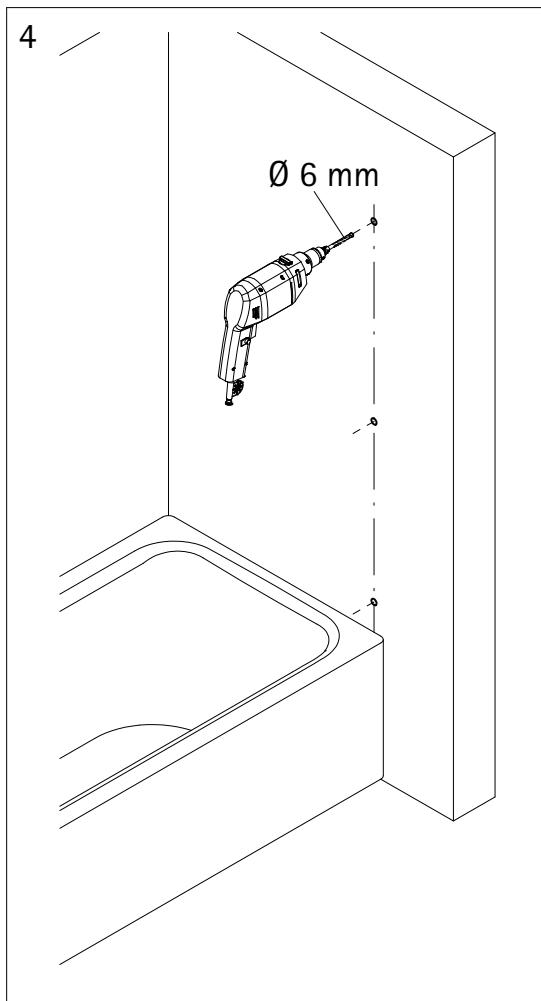
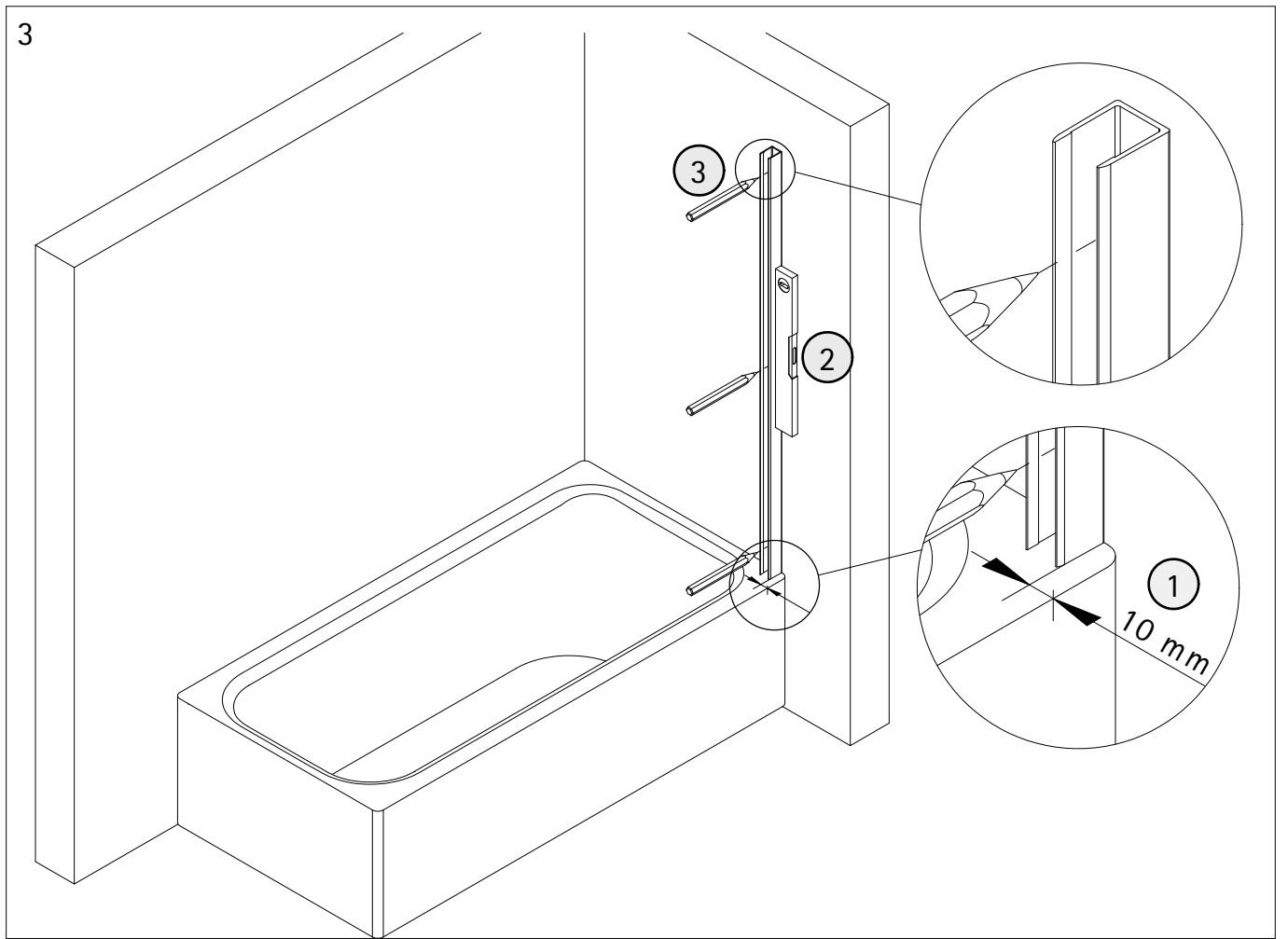

6

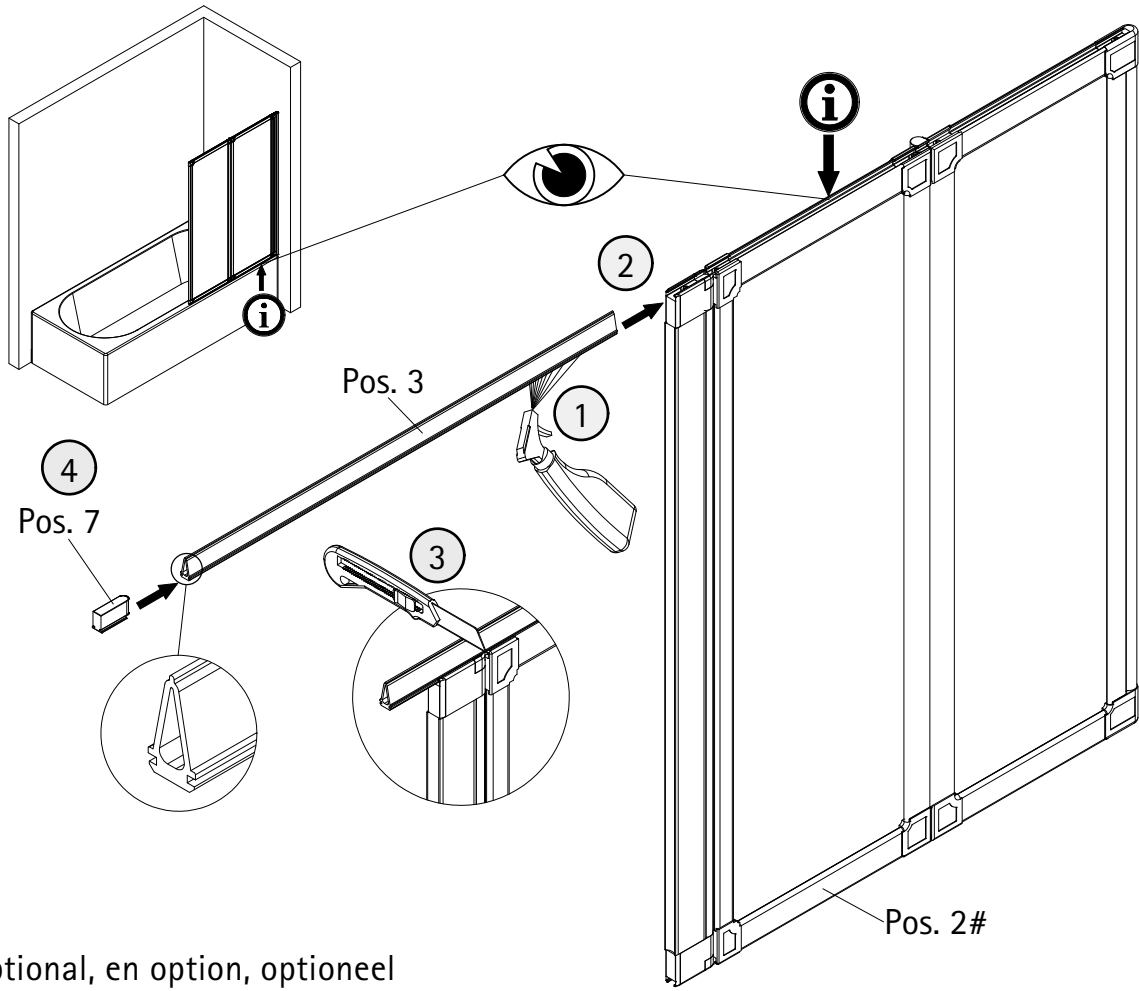

optional, en option, optioneel

7

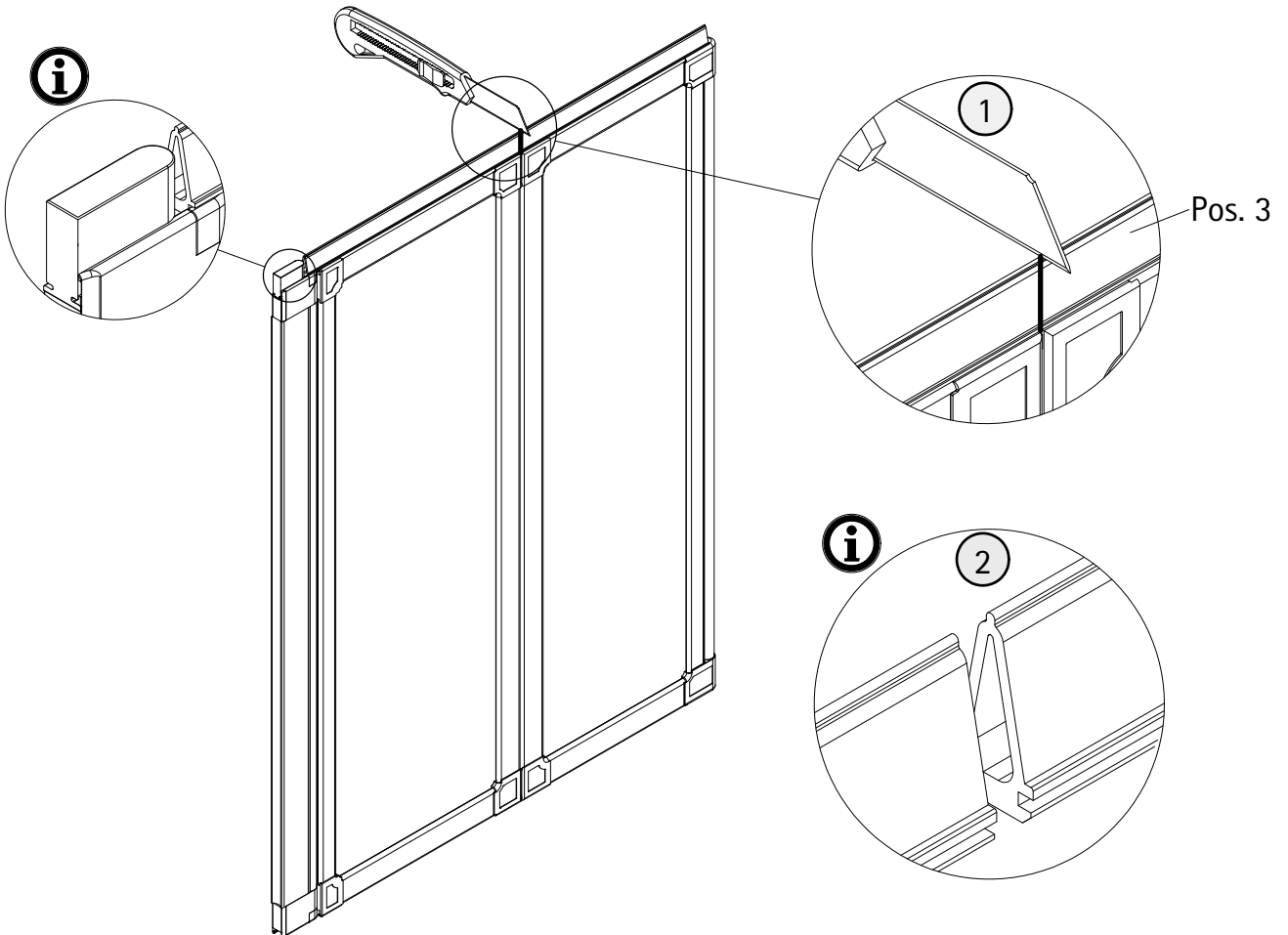

8

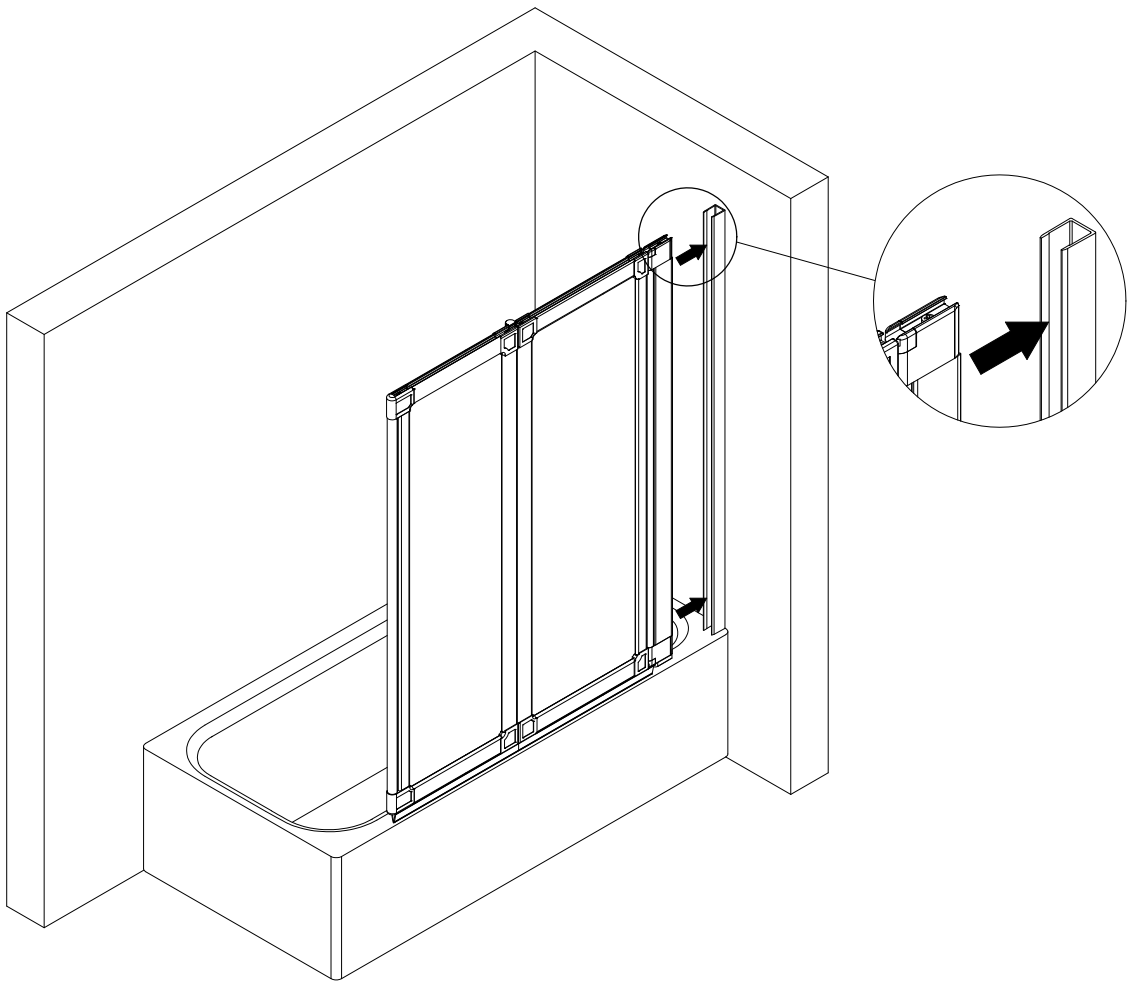

9

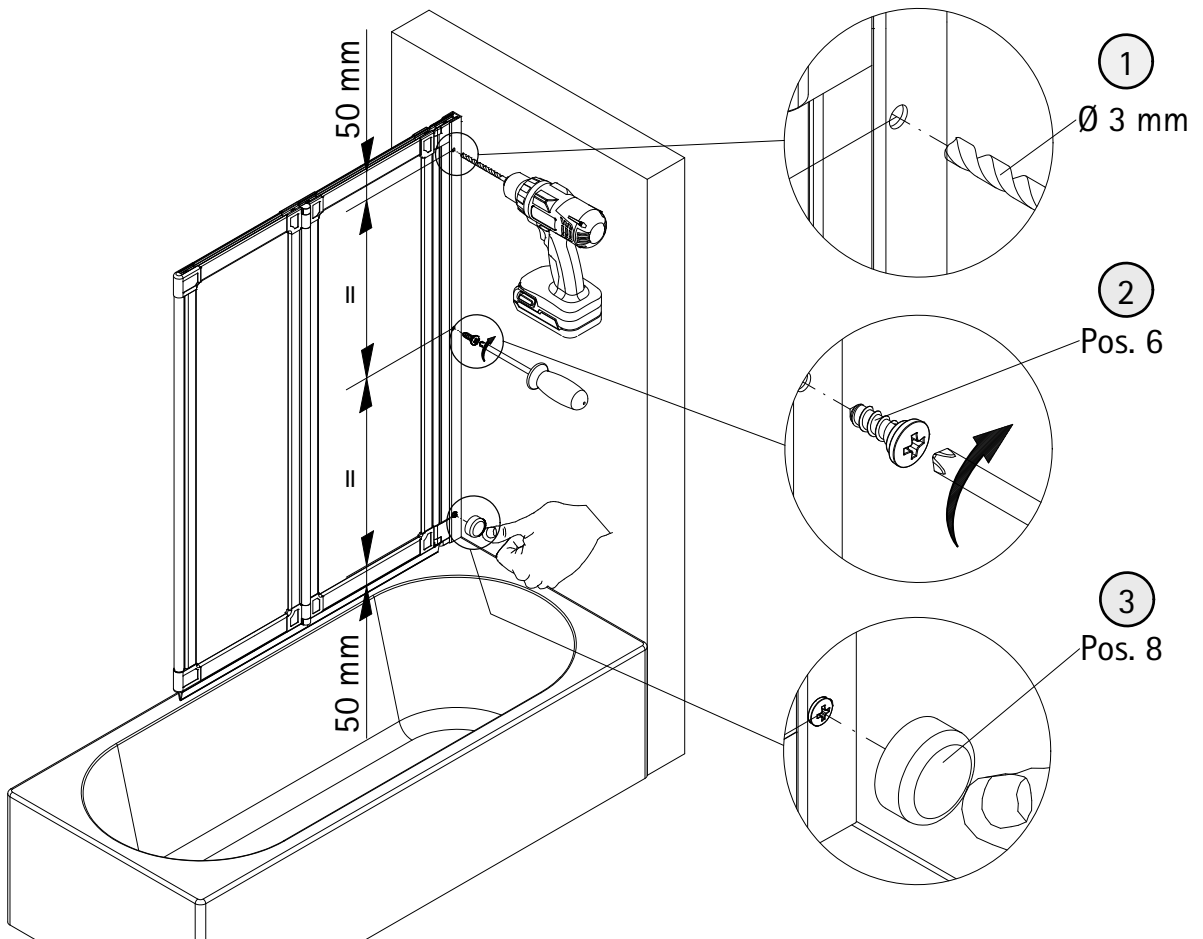

10

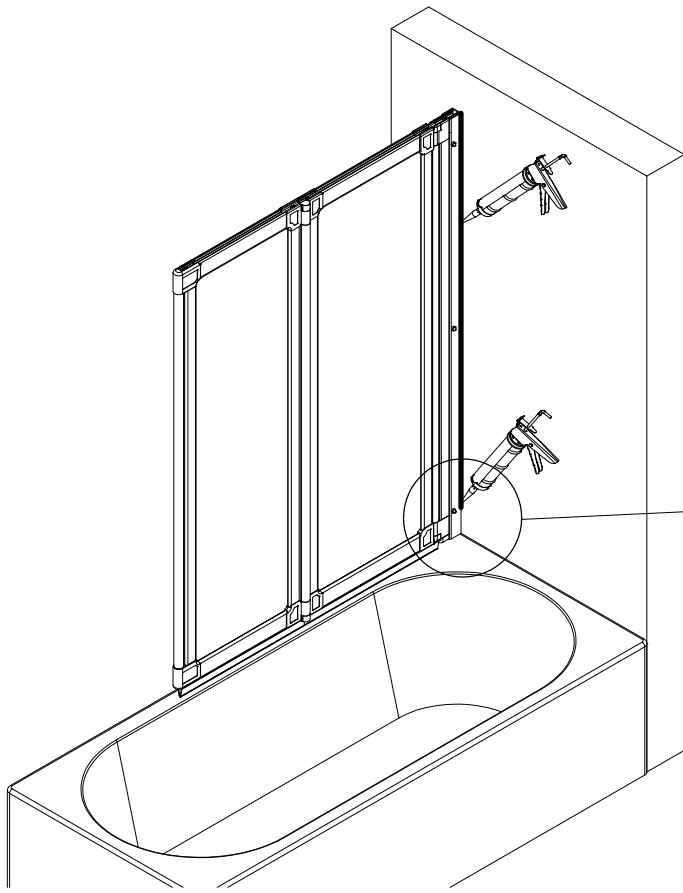

50 mm



11

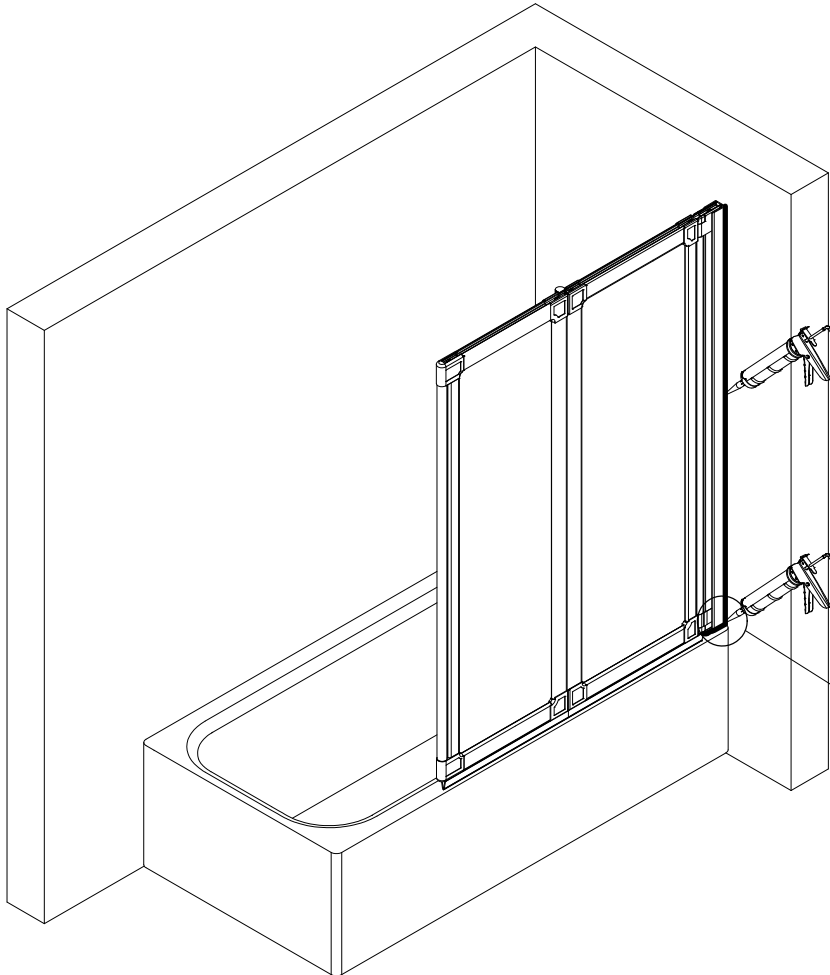

1557-2

Kontrollbeleg
Control Receipt
Justificatif de contrôle
Controle-attest

Prüfnummer/ Inspection number / Numéro d'essai / Controlnummer



Duschservice
Zum Hohlen Morgen 22
59939 Olsberg
Deutschland / Germany / Allemagne / Duitsland



Ersatzteilbestellung:
Fax 02962 / 972-4260



Allgemeine technische Probleme:
Telefon 02962 / 97240



E-Mail:
ersatzteile@duschservice.de