

Health and Safety Information

Please read and observe the health and safety information. Failure to do so could result in injury or damage. Adults should supervise the use of this product by children.

WARNING – SEIZURES

- Some people (about 1 in 4000) may have seizures or blackouts triggered by light flashes or patterns, and this may occur while they are watching TV or playing video games, even if they have never had a seizure before.
 - Anyone who has ever experienced seizures, loss of awareness or any other symptom linked to an epileptic condition should consult a doctor before playing video games.
 - Parents or legal guardians should monitor children when they play video games. Stop playing and consult a doctor if you or your child have any unusual symptoms, such as: **convulsions, eye or muscle twitching, loss of awareness, altered vision, involuntary movements or disorientation.**
- **To reduce the likelihood of a seizure when playing video games, follow these precautions:**
1. Do not play if you are tired or need sleep.
 2. Play in a well-lit room.
 3. Take a break of 10 to 15 minutes every hour.

WARNING – EYE STRAIN AND MOTION SICKNESS

Playing video games can make your eyes hurt after a sustained period of time. Playing video games can also cause motion sickness in some players. Follow these instructions to avoid eye strain, dizziness or nausea:

- Avoid excessively long play sessions. Parents or legal guardians should monitor their children for appropriate play.
- Take a break of 10 to 15 minutes every hour, even if you don't think you need it.
- If your eyes become tired or sore while playing, or if you feel dizzy, nauseated or tired, stop and rest for several hours before playing again.
- If you continue to have any of the above symptoms or other discomfort during or after play, stop playing and see a doctor.

WARNING – REPETITIVE MOTION INJURIES

Playing video games can make your muscles, joints or skin hurt after a few hours. Follow these instructions to avoid problems such as tendonitis, carpal tunnel syndrome or skin irritation:

- Avoid excessively long play sessions. Parents or legal guardians should monitor their children for appropriate play.
- Take a break of 10 to 15 minutes every hour, even if you don't think you need it.
- If your hands, wrists or arms become tired or sore while playing, or if you feel symptoms such as **tingling, numbness, burning or stiffness**, stop and rest them for several hours before playing again.
- If you continue to have any of the above symptoms or other discomfort during or after play, stop playing and see a doctor.

WARNING – ELECTRICAL SAFETY

To avoid risk of overheating, fire, explosion, electric shock, injury, deformation and/or malfunction:

- Do not use the console during a lightning storm.
- Do not disassemble, make alterations to or try to repair the console.
- Do not step on, forcefully bend or pull on the cables of the console. When unplugging the console from the power supply, turn off the console first and pull on the plug rather than the cable.
- Do not allow liquids or foreign substances to enter the console. In the event liquid (e.g. water, juice, oil or pet urine) or foreign substances enter the console, immediately stop using it, turn the power off, disconnect the console from the power supply and contact Nintendo Customer Support for advice on how to proceed.
- Only use an AC adapter that is compatible with this console, such as the separately sold Nintendo USB AC adapter (CLV-003(UKV)/CLV-003(EUR)) or another USB-compatible SV/1A (5W) output AC adapter. Please make sure to use an AC adapter that has been approved for use in your country, and read its instruction manual to ensure that it is able to supply power to this console.
- When connecting the USB cable to the console or to a power supply, make sure the connector on the USB cable is oriented correctly and then insert it straight into the USB port.
- Do not touch connector terminals with your fingers or metal objects.
- Do not touch the console with wet, sweaty or oily hands.
- Do not use voltage transformers intended for use in other countries, or incandescent-specific light dimmers because it may change the power voltage.
- Do not overload the circuit by connecting an excessive amount of equipment to plug sockets or wiring accessories (e.g. connecting a series of multi-plug adapters).

- If you hear a strange noise, see smoke, or smell something strange when using the console, immediately turn off the power, disconnect the console from the power supply and contact Nintendo Customer Support.

WARNING – GENERAL

- **Not suitable for young children – strangulation hazard. The cord of the controller can coil around the neck. Do not place the console or its accessories within reach of young children or pets.**

Children may place the cables or other accessories into their mouths and cause injury. Please immediately dispose of any unwanted packaging after removing the products. Small children may accidentally swallow packing materials.

Use your console carefully

- **Do not use or store the console in a high temperature or humid environment, such as:**
 - Areas exposed to direct sunlight
 - Near a heat source, such as a stove or heater
 - On top of a thermal or deep-piled carpet
 - On top of audiovisual equipment
 - Areas without ventilation, such as in a vehicle during the summer
- **Do not use or store the console in places with high levels of dust, fumes or tobacco smoke. If dust or other foreign material forms on the terminals or connectors of the console or cables, remove it using a vacuum cleaner, dry cloth or other appropriate product.**
- **Do not use or place the console in places where the temperature can suddenly change and cause condensation, such as in front of air conditioning units. If condensation forms, turn the console off and wait until the water droplets have evaporated.**
- **The console is for indoor use only.**
- **Do not expose the console to severe physical shock.**
- **Do not use excessive force when connecting cables or other accessories.**
- **Only use compatible accessories.**
- **If the console is damaged, please contact Nintendo Customer Support. Do not touch damaged areas. Avoid contact with any leaking fluid.**

Using this Console

Getting Started

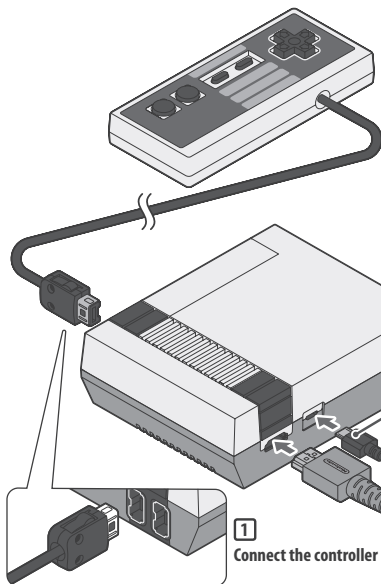

USB



Connecting to a power supply

Please use one of the following:

- Nintendo USB AC adapter (CLV-003(UK)/CLV-003(EUR)) (sold separately)
- USB-compatible 5V/1A (5W) output AC adapter (sold separately)

Note: While some USB-compatible devices may be able to supply power to the console, Nintendo cannot recommend any particular device. Please make sure to follow the instructions of any third-party device.

Note: The illustration above shows the UK version of the Nintendo USB AC adapter. Pull out the earth pin before inserting the plug into the socket.

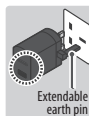

Extendable earth pin

2 Connect the USB cable (power supply)

3 Connect the High Speed HDMI™ cable

HDMI
HDMI port on TV or monitor



WARNING

Make sure the connectors on the cables are oriented correctly and then insert them straight into the correct ports.

4 Turn the console on

The HOME Menu will be displayed. Please follow the on-screen instructions.



Pressing this button while playing a game will create a suspend point and return you to the HOME Menu.



On/Off

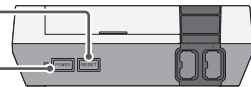

After Playing

In order to avoid malfunction or loss of data, please first turn the console off, then disconnect the AC adapter from the socket and/or disconnect the USB cable from the console.

Power-Saving Mode

The console will automatically switch off after one hour with no input (a suspend point will be created if a game is running). This means that the console will be switched off but the POWER Button will still be in the "on" position. The next time you use the console, you will have to set the POWER Button to the "off" position and then return it to the "on" position to turn the power on.