

home

for quality home and office furniture

piranha[®] REGAL ASSEMBLY INSTRUCTIONS

Please read this guide carefully and check that you have all parts before you begin assembly. As a thank you for your purchase, we would like to offer you a 10% discount* off our range of matching furniture on www.homeinonline.com with voucher code **10%MATCH**.

Need help with your item or unhappy?

If you have **ANY** questions, please do not hesitate to email us on info@homeinonline.com and we will do our very best to help. You can also contact us via our website www.homeinonline.com

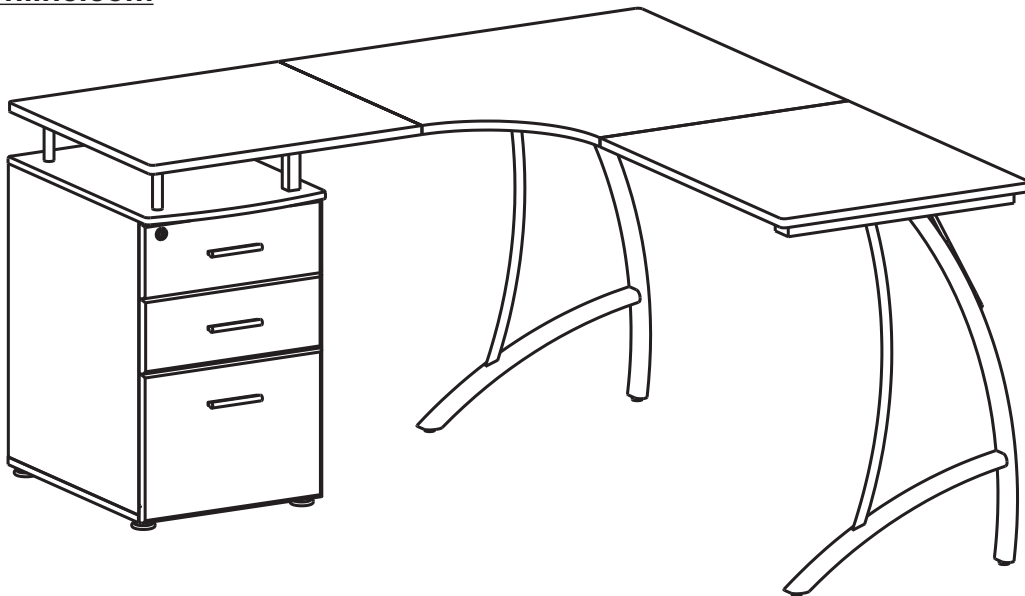

TWO PEOPLE RECOMMENDED

PC28 (REGAL)









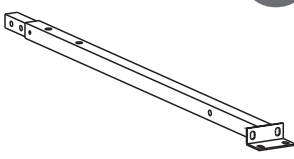
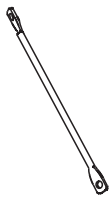

General Care:

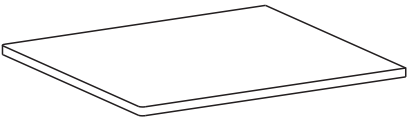
Keep furniture out of direct sunlight. Use mats and coasters to protect surfaces.
Do not place hot or wet items directly onto unprotected surfaces.

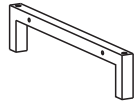
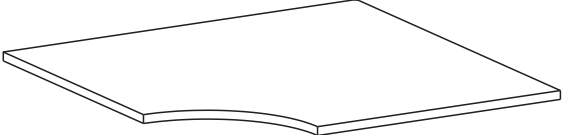
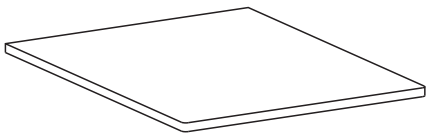
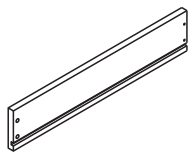
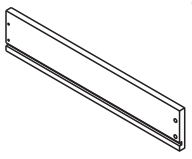
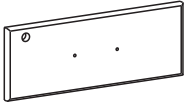
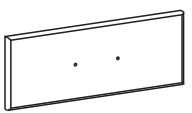
Cleaning:

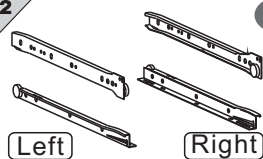
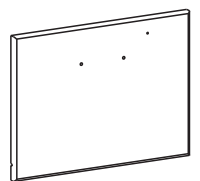
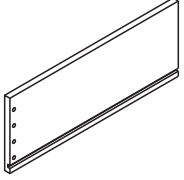
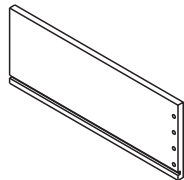
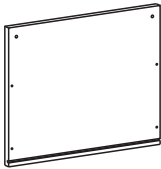
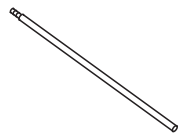
Wipe surfaces with a clean damp (not wet) cloth then dry with a clean lint free cotton cloth.
Glass surfaces may be polished with window or other glass cleaning liquids.

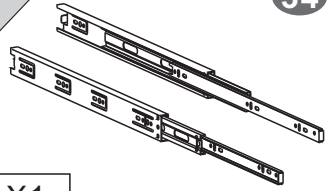
Please retain cartons until assembled as goods MUST be returned in original packaging.

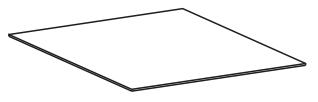
 <p>12</p>	 <p>13</p>	 <p>14</p>	 <p>15</p>
X2	X1	X1	X2
 <p>16</p>	 <p>17</p>	 <p>18</p>	
X1	X2	X1	
 <p>19</p>	 <p>20</p>		
X1	X1		
 <p>21</p>	 <p>22</p>	 <p>23</p>	 <p>24</p>
X2	X2	X1	X1
 <p>25</p>	 <p>26</p>	 <p>27</p>	 <p>28</p>
X2	X2	X2	X1
 <p>29</p>	 <p>30</p>	 <p>31</p>	 <p>32</p>
X1	X1	X1	X2
 <p>33</p>	 <p>34</p>	 <p>35</p>	 <p>36</p>
X3	X1	X2	X1

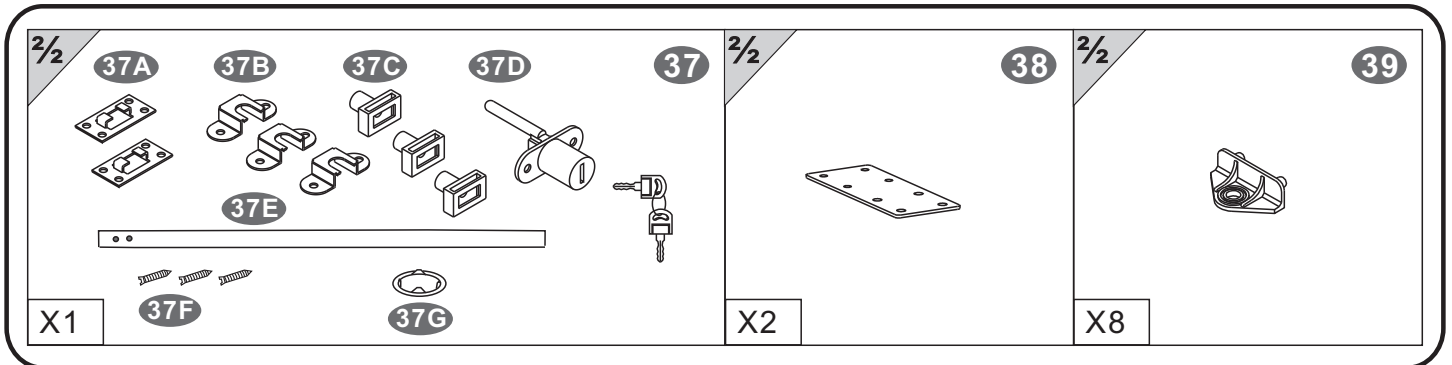

▪SCREWS LIST

PART	QTY.	ITEM	
A	60	3X15 MM	
B	16	6X40 MM	
C	2	6X30 MM	
D	24	6X35 MM	
E	26	6X12 MM	
F	2	6X115 MM	
G	4	6X40 MM	
H	12	4X35 MM	

PART	QTY.	ITEM	
I	6	4X20 MM	
J	6	M6	
K	16	4X14 MM	
L	16	Φ 15 MM	
M	8	8X30 MM	
	1		
	1		
	1		

6X40MM BOLT INSTALLATION AS BELOW:

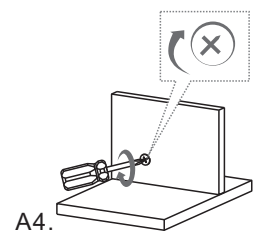
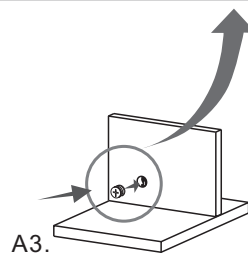
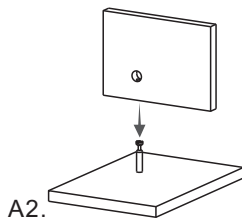
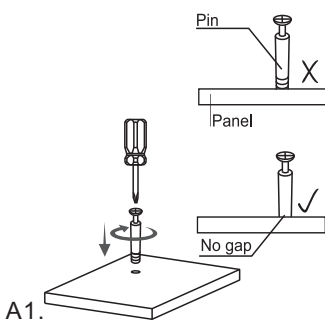
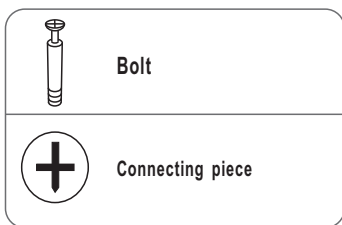



■ ASSEMBLY STEPS:

1

■ SCREWS
A 3X15 MM
x6

2

■ SCREWS
A 3X15 MM
x8

3

■ SCREWS
E 6X12 MM
x4

4

5

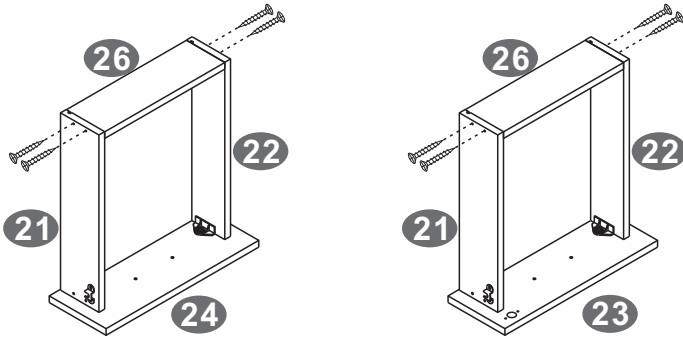

■ SCREWS

H 4X35 MM

 x8



6

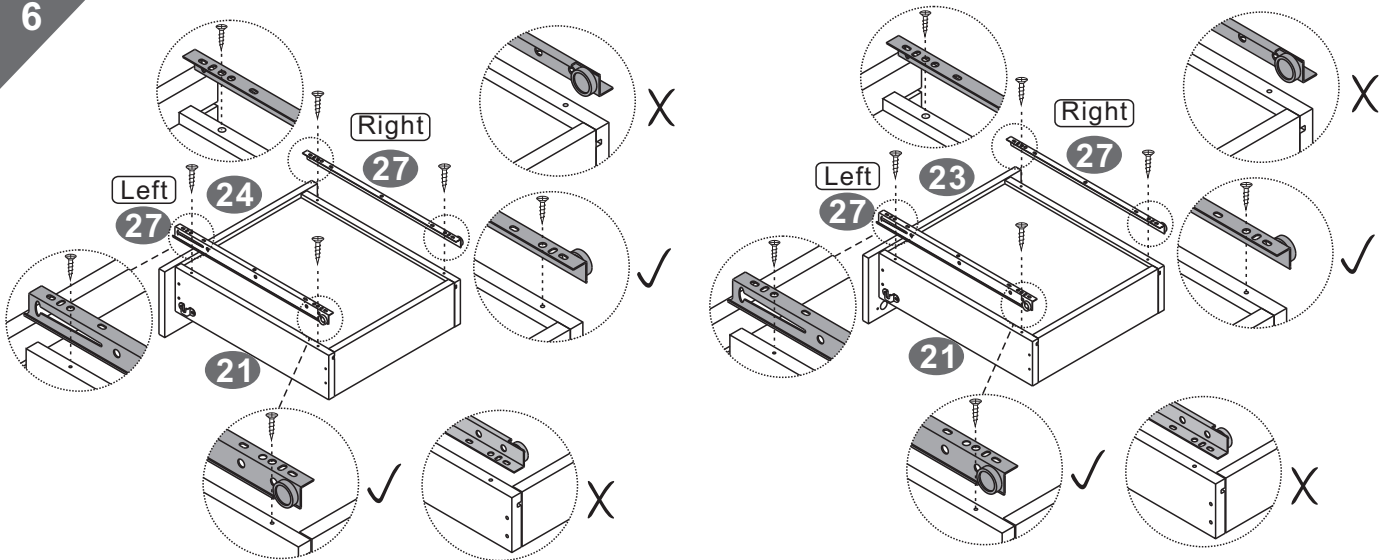

■ SCREWS

A 3X15 MM

 x8



7

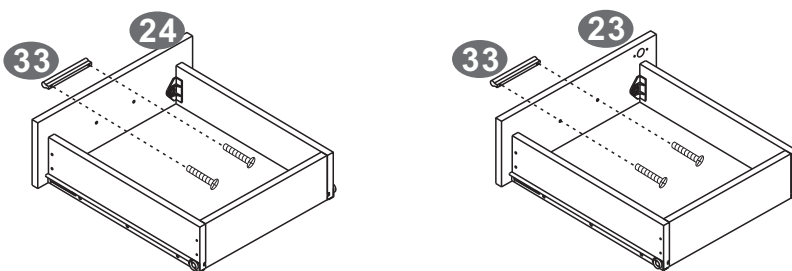

■ SCREWS

I 4X20 MM

 x4



8

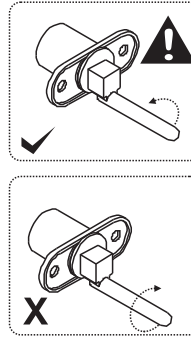
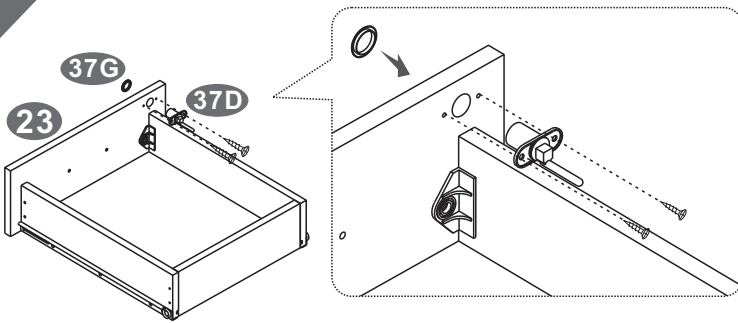

■ SCREWS

A 3X15 MM

x2



9

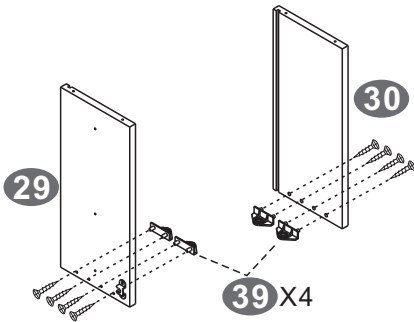

■ SCREWS

A 3X15 MM

x8



10

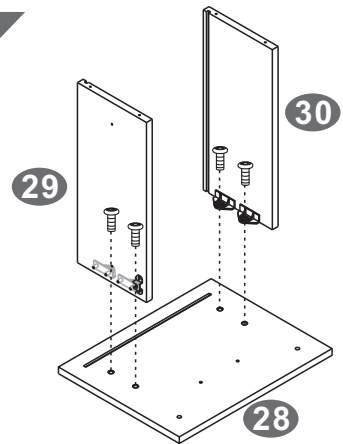

■ SCREWS

E 6X12 MM

x4



11

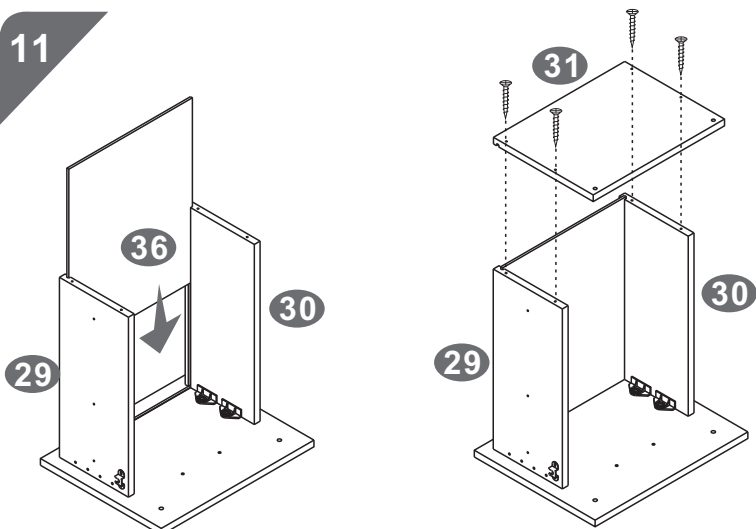

■ SCREWS

H 4X35 MM

x4



12

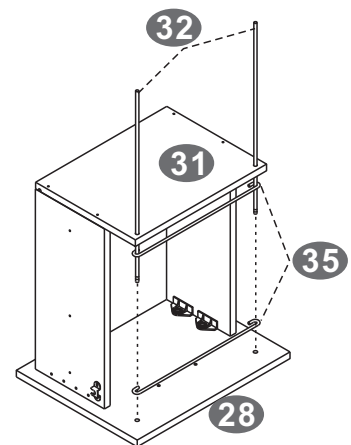

⚠ Be careful not to overtighten the metal rod or you will damage the drawer front.

13

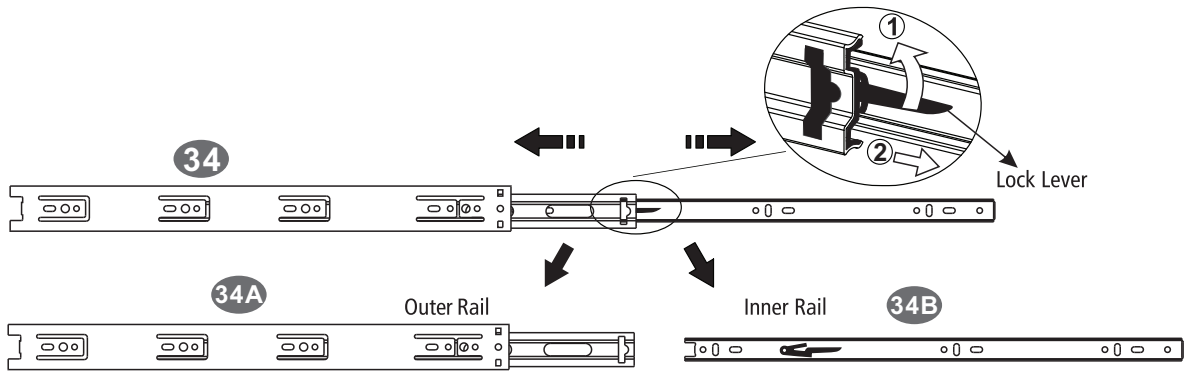

move the lock lever on the inner rail as shown and separate the outer rail (34a) and inner rail (34b) from the 2 file drawer slides (34)

14

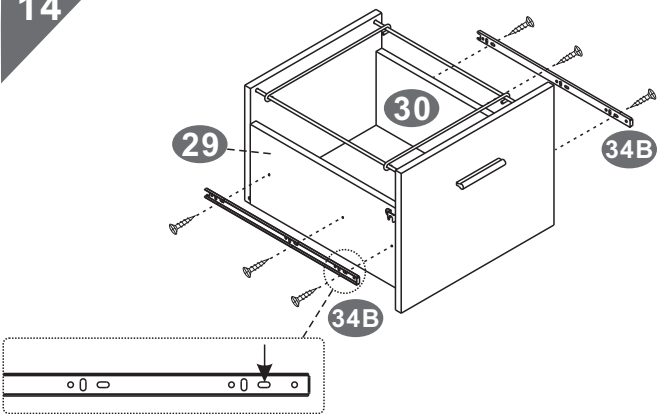

▪ SCREWS

A 3X15 MM

x6



15

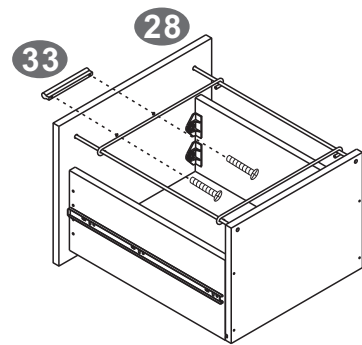

▪ SCREWS

I 4X20 MM

x2



16

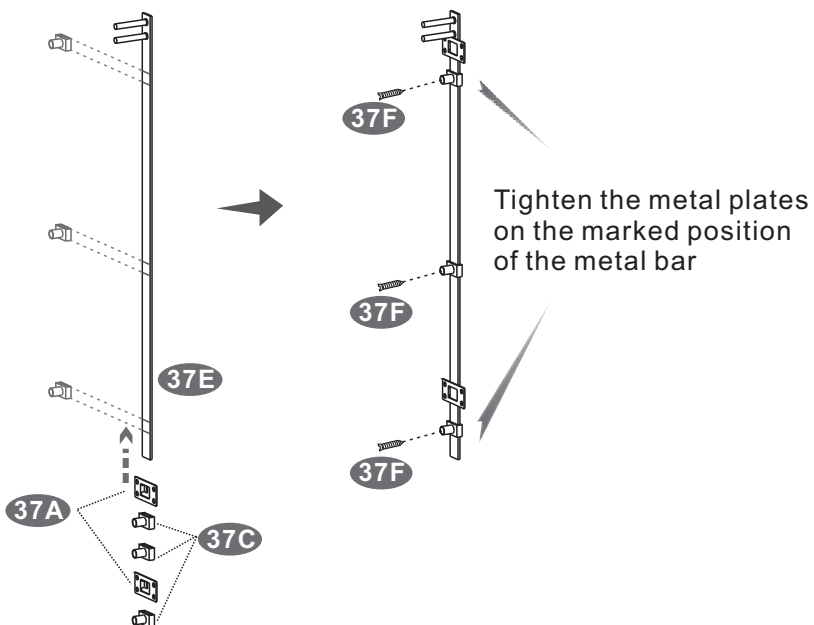

17

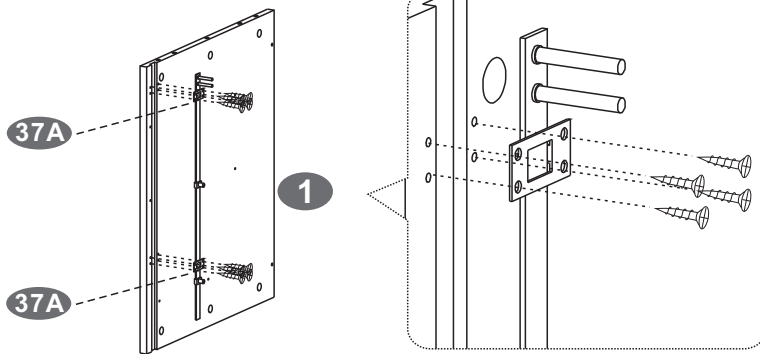

■ SCREWS

A 3X15 MM

x8



18

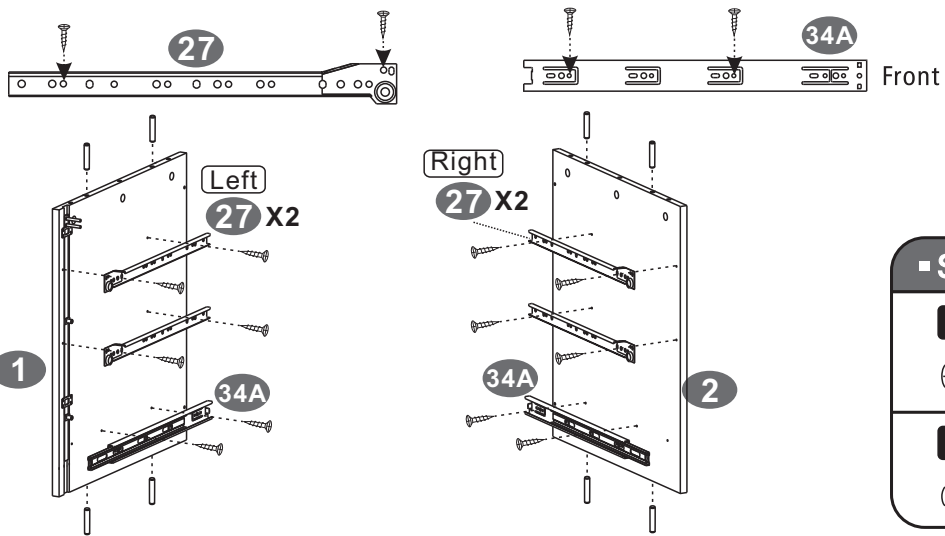

■ SCREWS

A 3X15 MM

x12



M 8X30 MM

x8

19

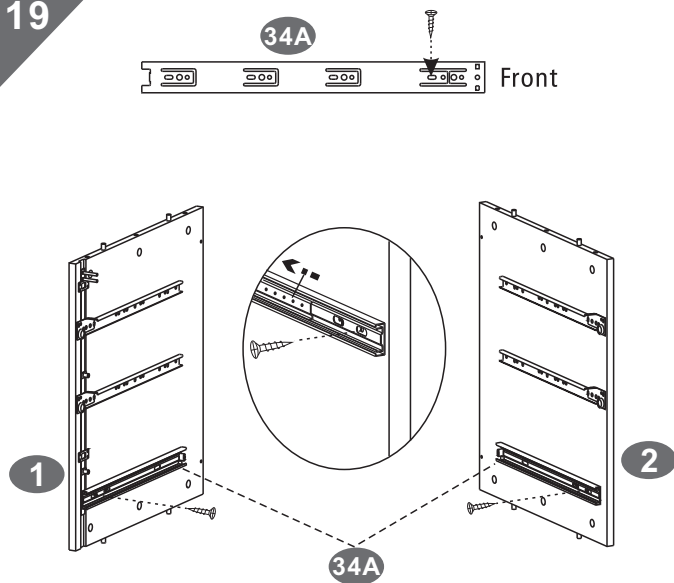

■ SCREWS

A 3X15 MM

x2



20

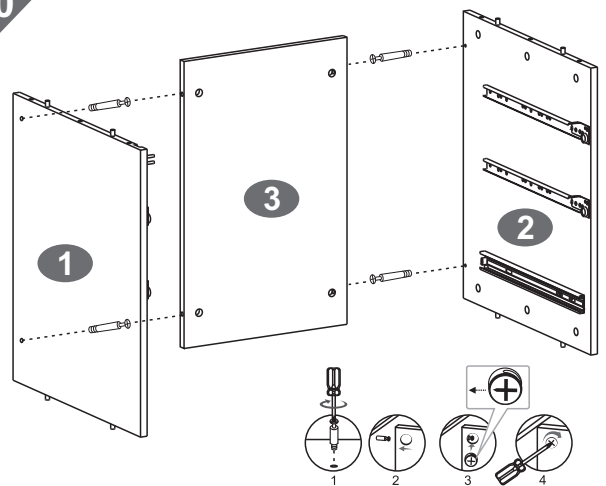

■ SCREWS

B 6X40 MM

x4



L Φ 15 MM

x4



21

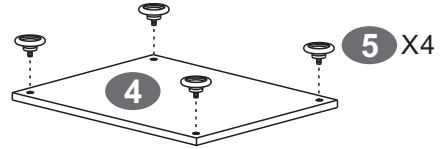
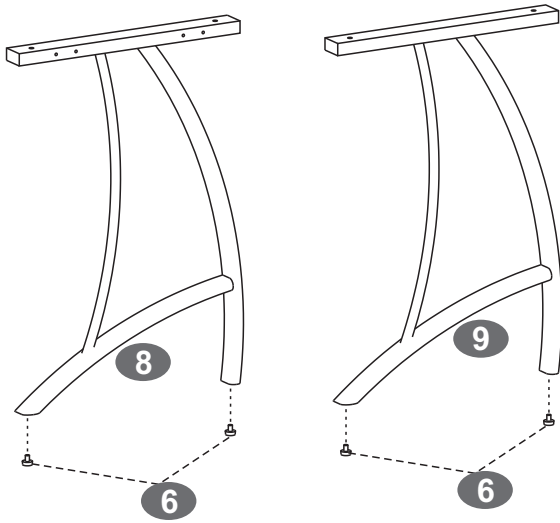

22

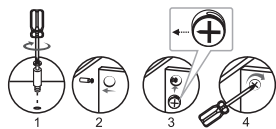
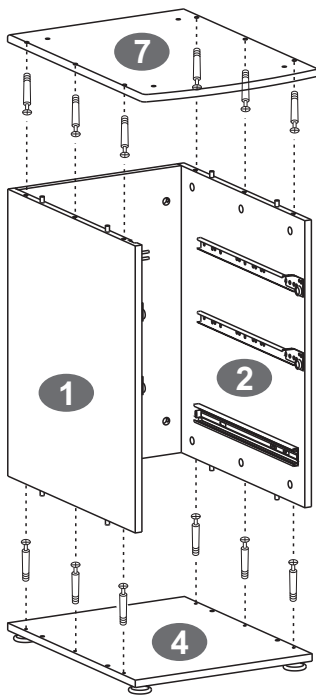

■ SCREWS

B 6X40 MM

x12

L Φ 15 MM

x12

23

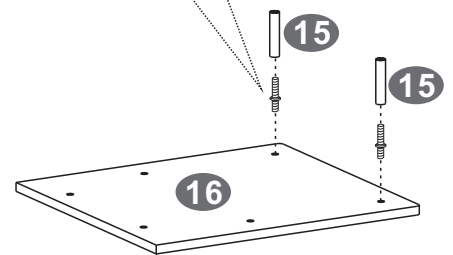
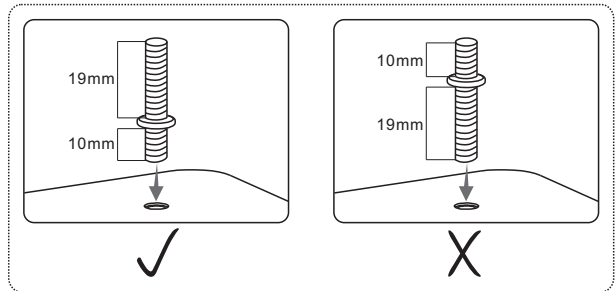





■ SCREWS

C 6X30 MM

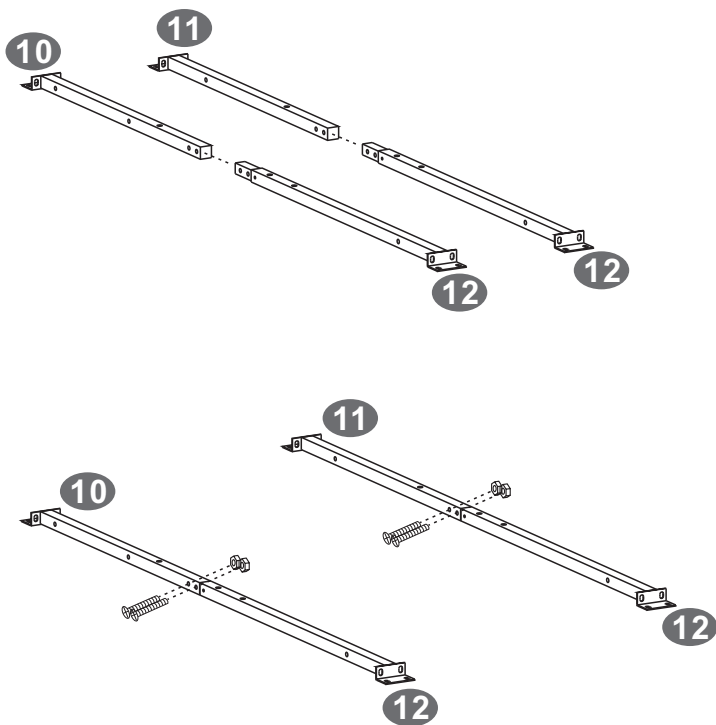
x2

24

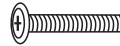

SCREWS	
D 6X35 MM	
 x4	
J M6	
 x4	

** There are 2 options to assemble our desk, please choose it according to your preference.

A
A1-A7

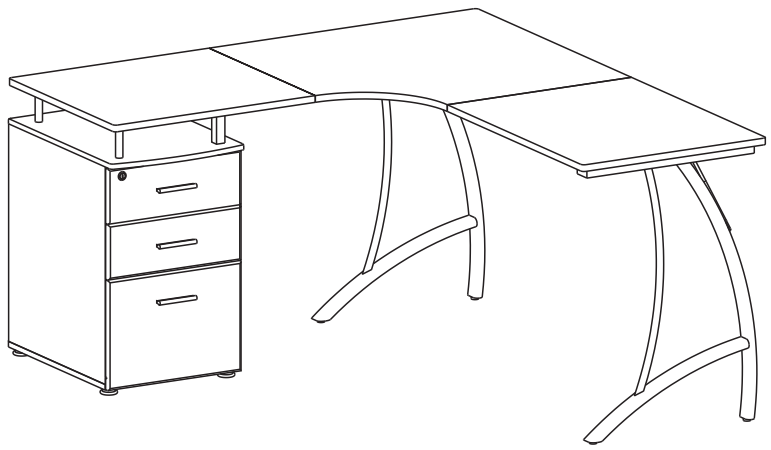

B
B1-B7

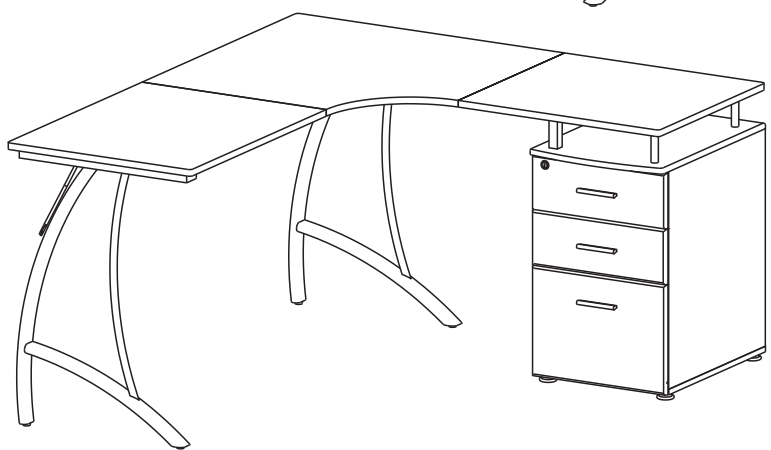

A1

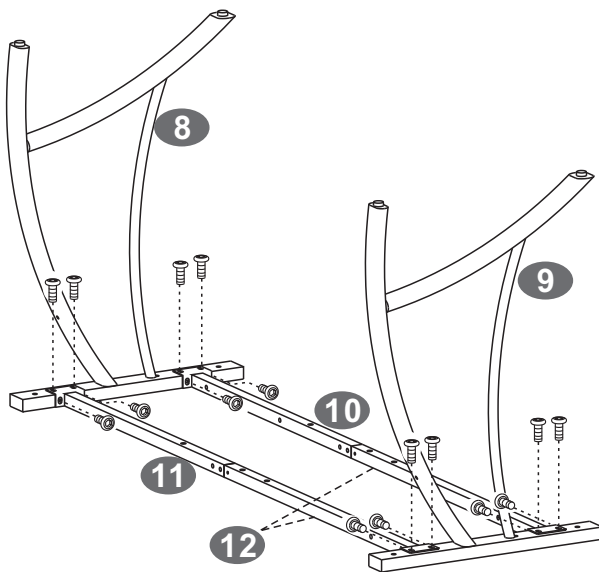

▪ SCREWS

E 6X12 MM

 x16



A2

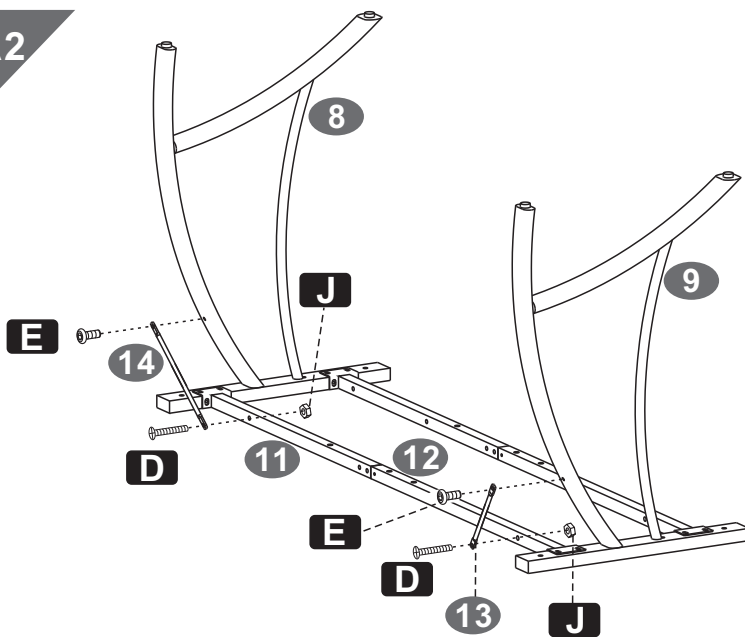

▪ SCREWS

D 6X35 MM

 x2



E 6X12 MM

 x2



J M6

 x2



A3

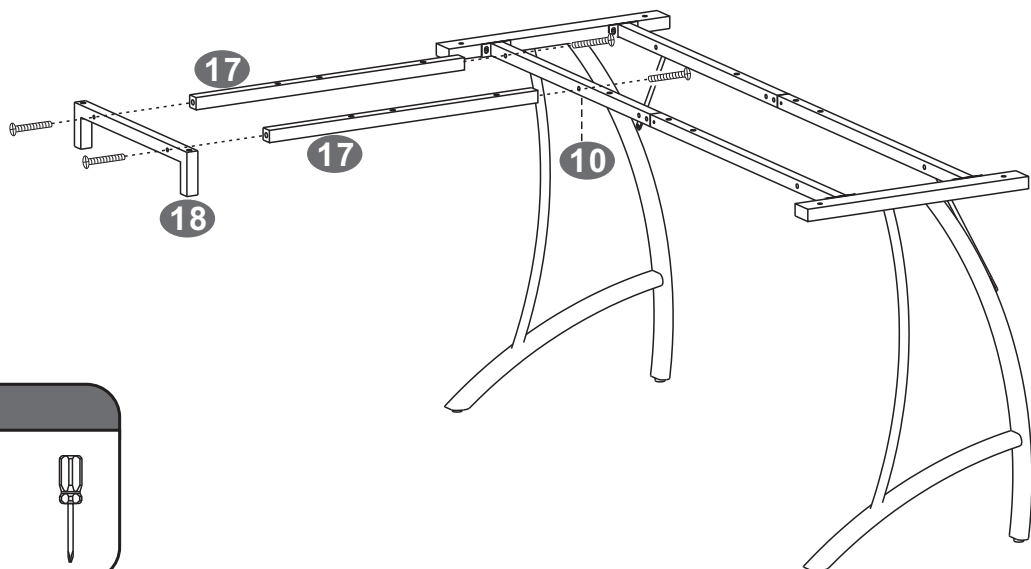

▪ SCREWS

G 6X40 MM

 x4



A4

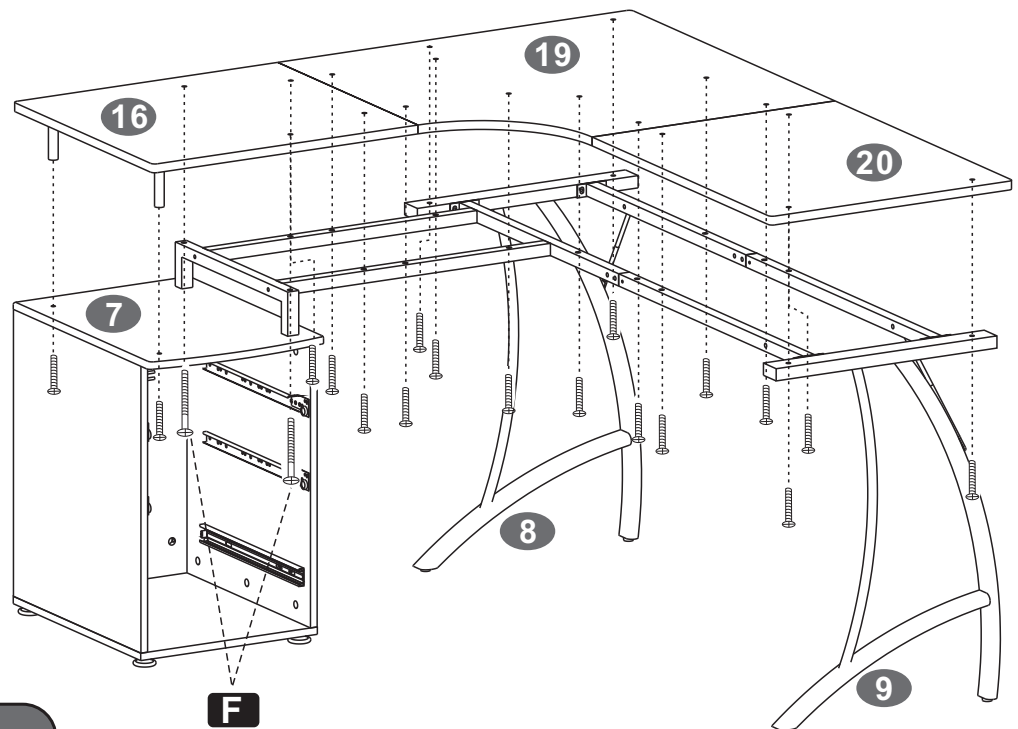

SCREWS

D 6X35 MM

x18



F 6X115 MM

x2



A5

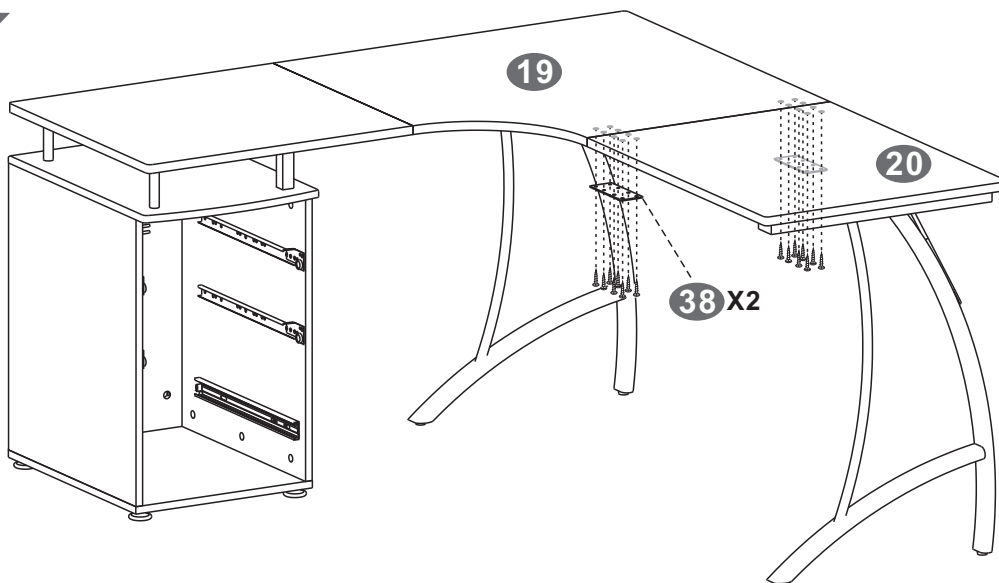

SCREWS

K 4X14 MM

x16



A6

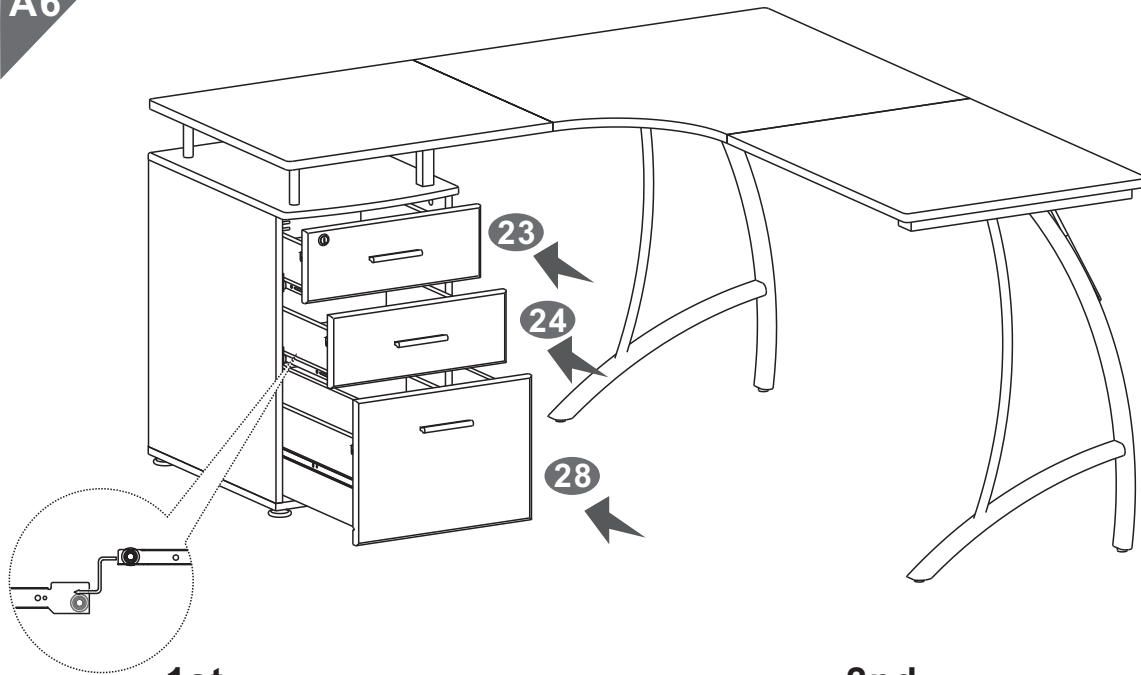

1st

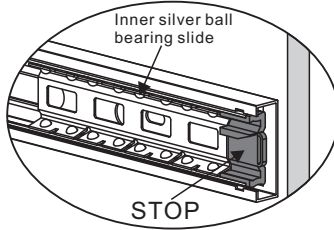

Ensure the ball bearing glider is positioned at the front against the plastic end stop

2nd

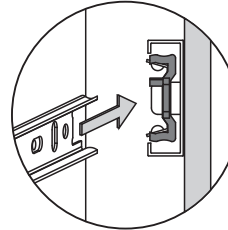

Keeping both runner slides fully extended, align the drawer runners and then slide drawer all the way into the closed position applying a little force if required.

A7

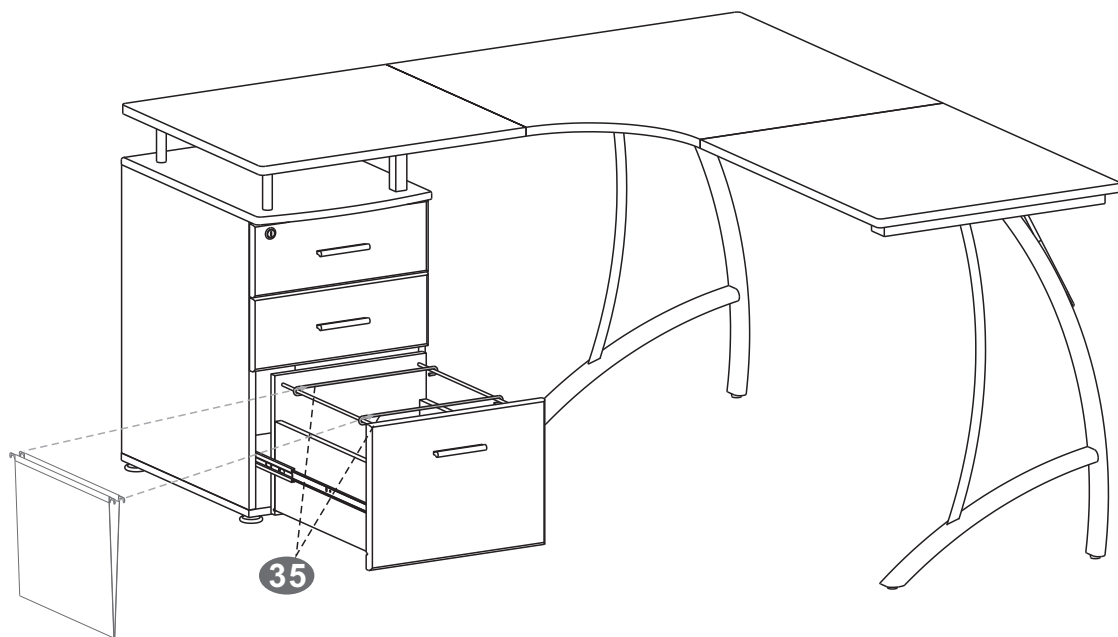

Please hang files on the movable metal hook part 35

B1

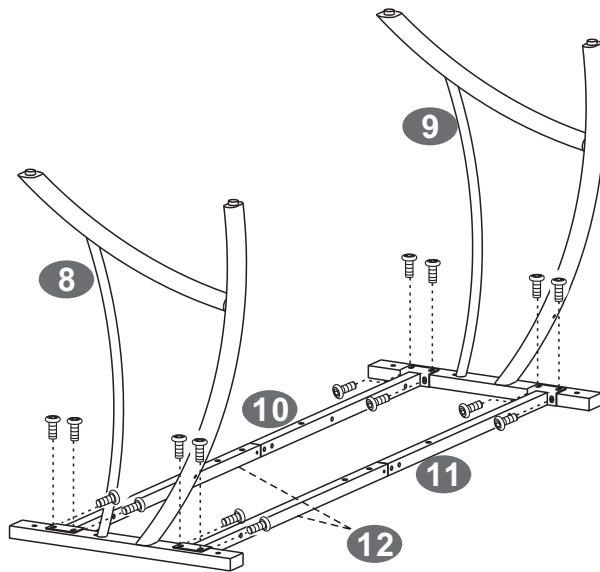

SCREWS

E 6X12 MM

x16



B2

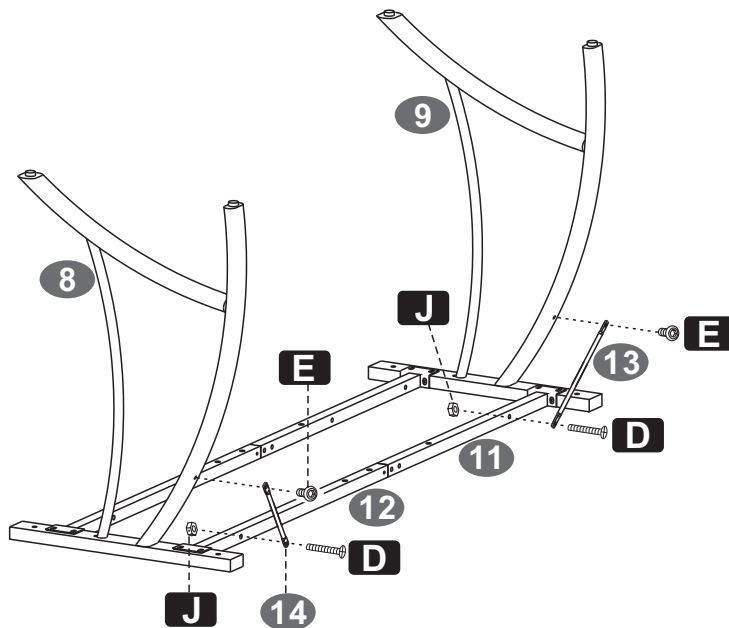

SCREWS

D 6X35 MM

x2



E 6X12 MM

x2



J M6

x2



B3

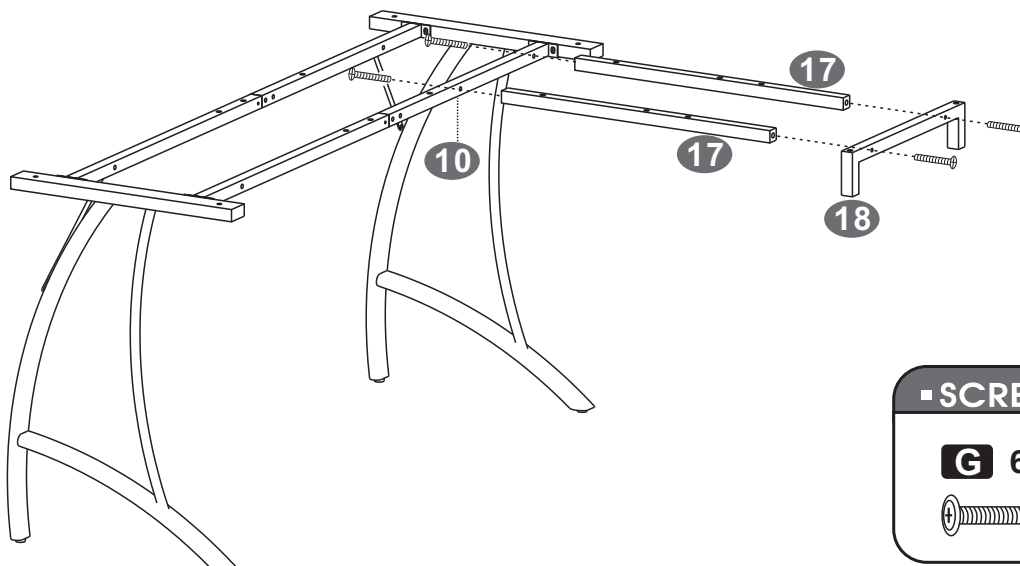

SCREWS

G 6X40 MM

x4



B4

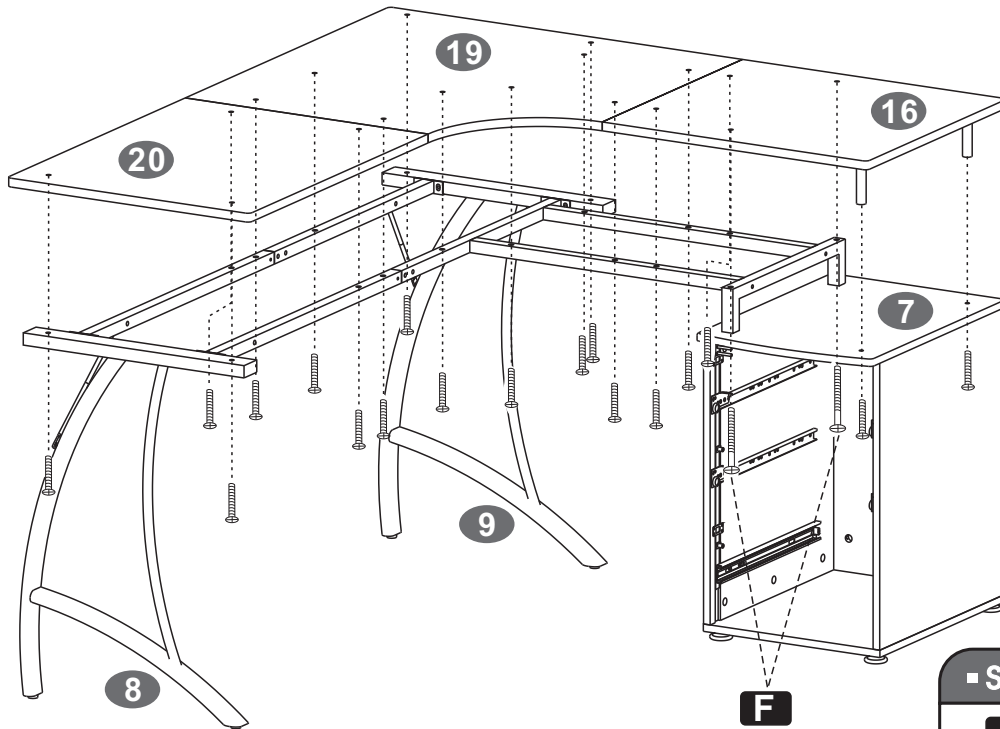

SCREWS

D 6X35 MM

x18



F 6X115 MM

x2



B5

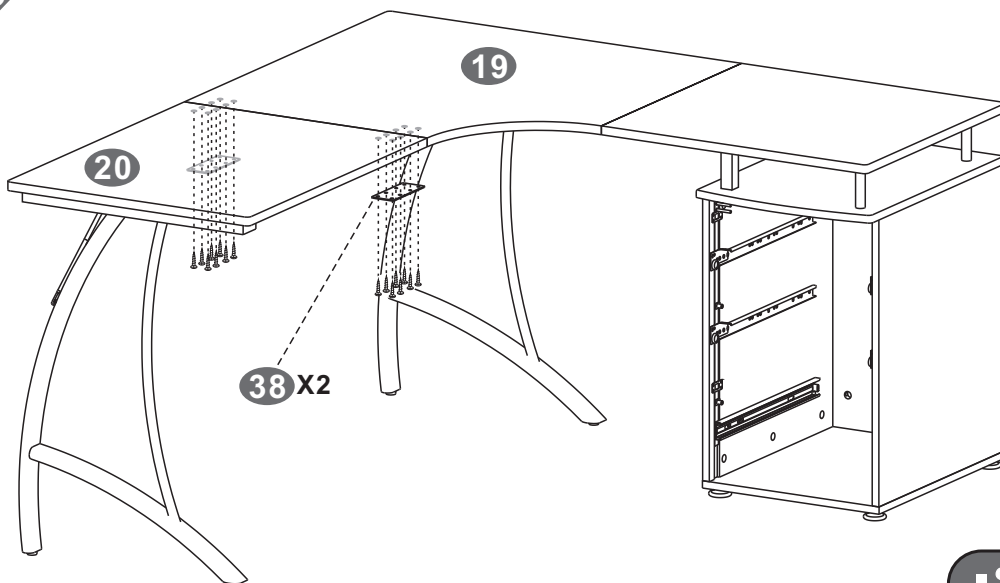

SCREWS

K 4X14 MM

x16



B6

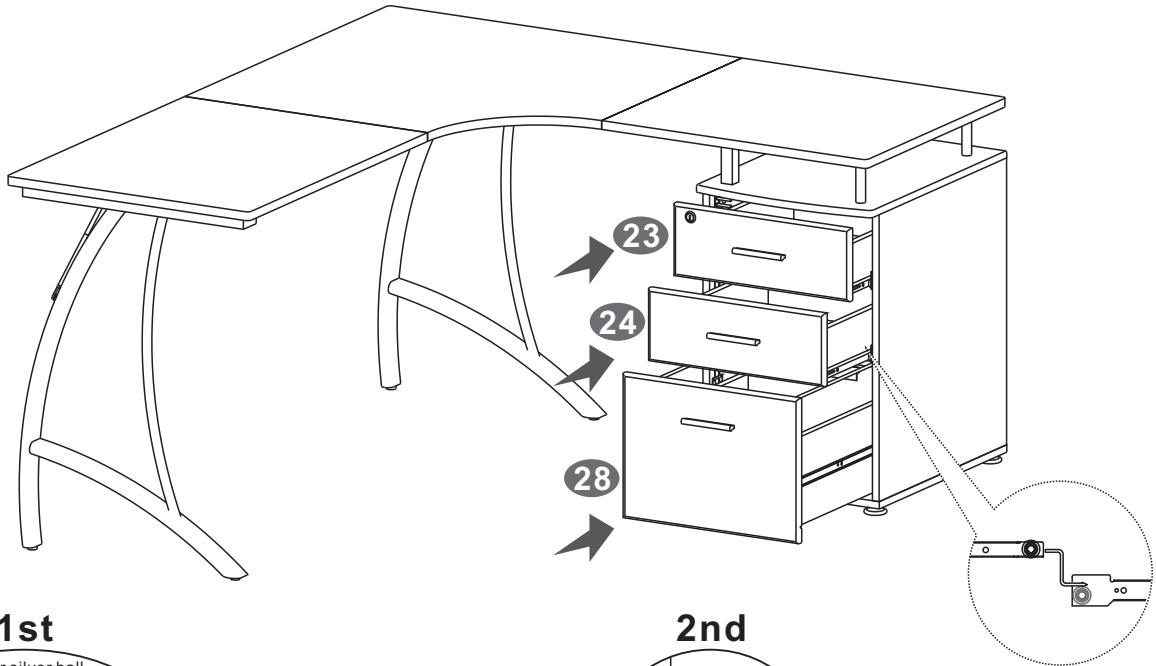

1st

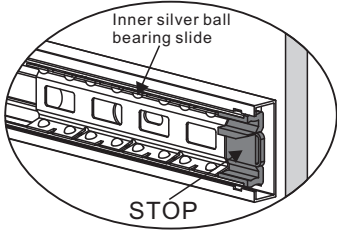

Ensure the ball bearing glider is positioned at the front against the plastic end stop

2nd

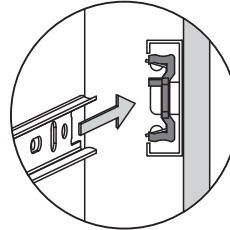

Keeping both runner slides fully extended, align the drawer runners and then slide drawer all the way into the closed position applying a little force if required.

B7

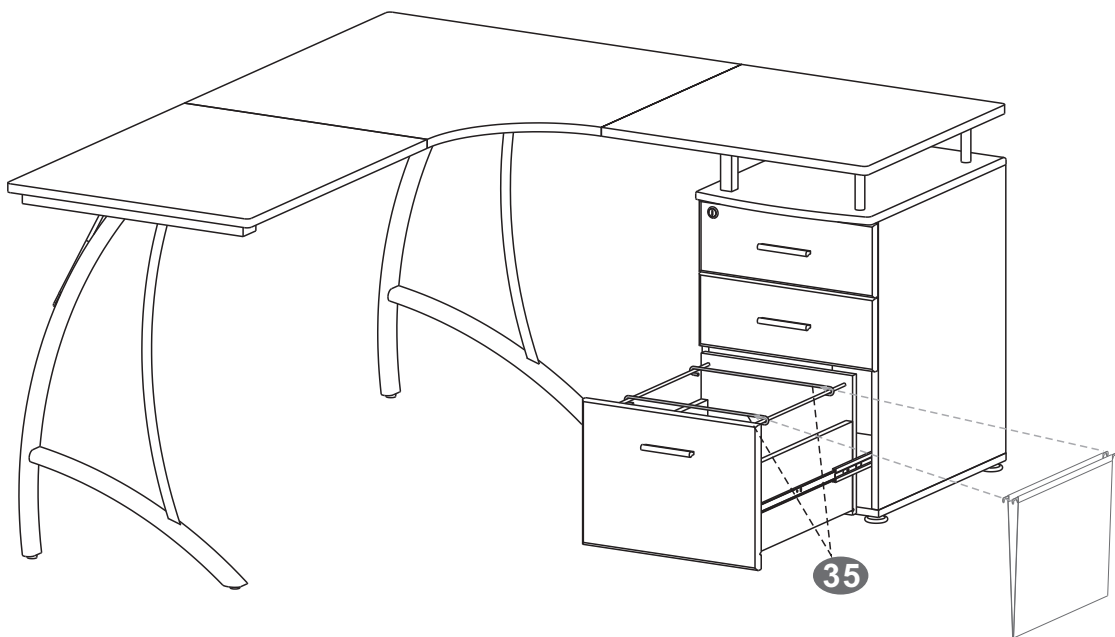

Please hang files on the movable metal hook part 35