

# KLUIS NACHTKASTJE

Nachttisch • Table de chevet • Nightstand

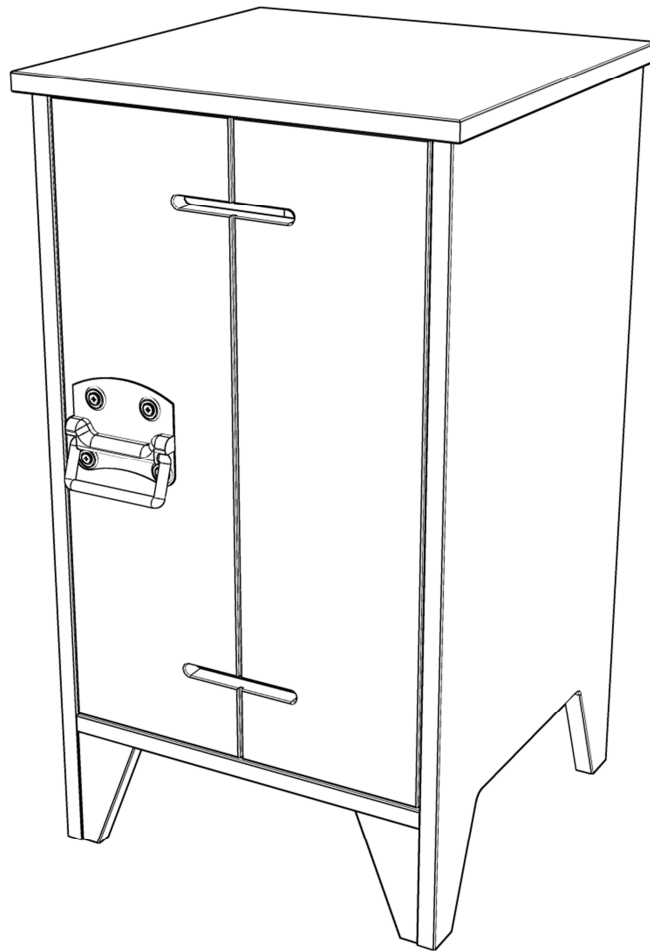

MADE BY  
**wood**

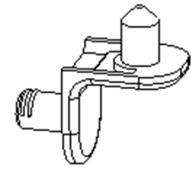
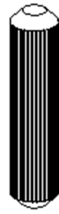

24mm	Ø15mm	Ø8x35mm	LIJM	Ø5
103	102	601	607	349
<b>12x</b>	<b>12x</b>	<b>18x</b>	<b>1x</b>	<b>4x</b>

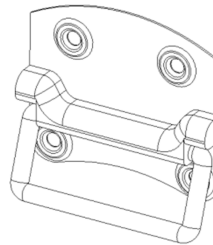
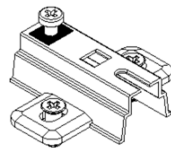
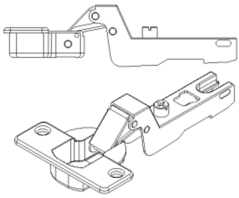

Ø35 15V	4mm	4x16mm	90x75mm	4x16mm
413	434	271	570	271
<b>2x</b>	<b>2x</b>	<b>4x</b>	<b>1x</b>	<b>4x</b>

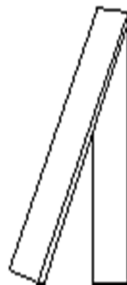

Ø 1,4x25mm	safty balance	Ø14mm
316	356	373x374
<b>25x</b>	<b>1x</b>	<b>6x</b>

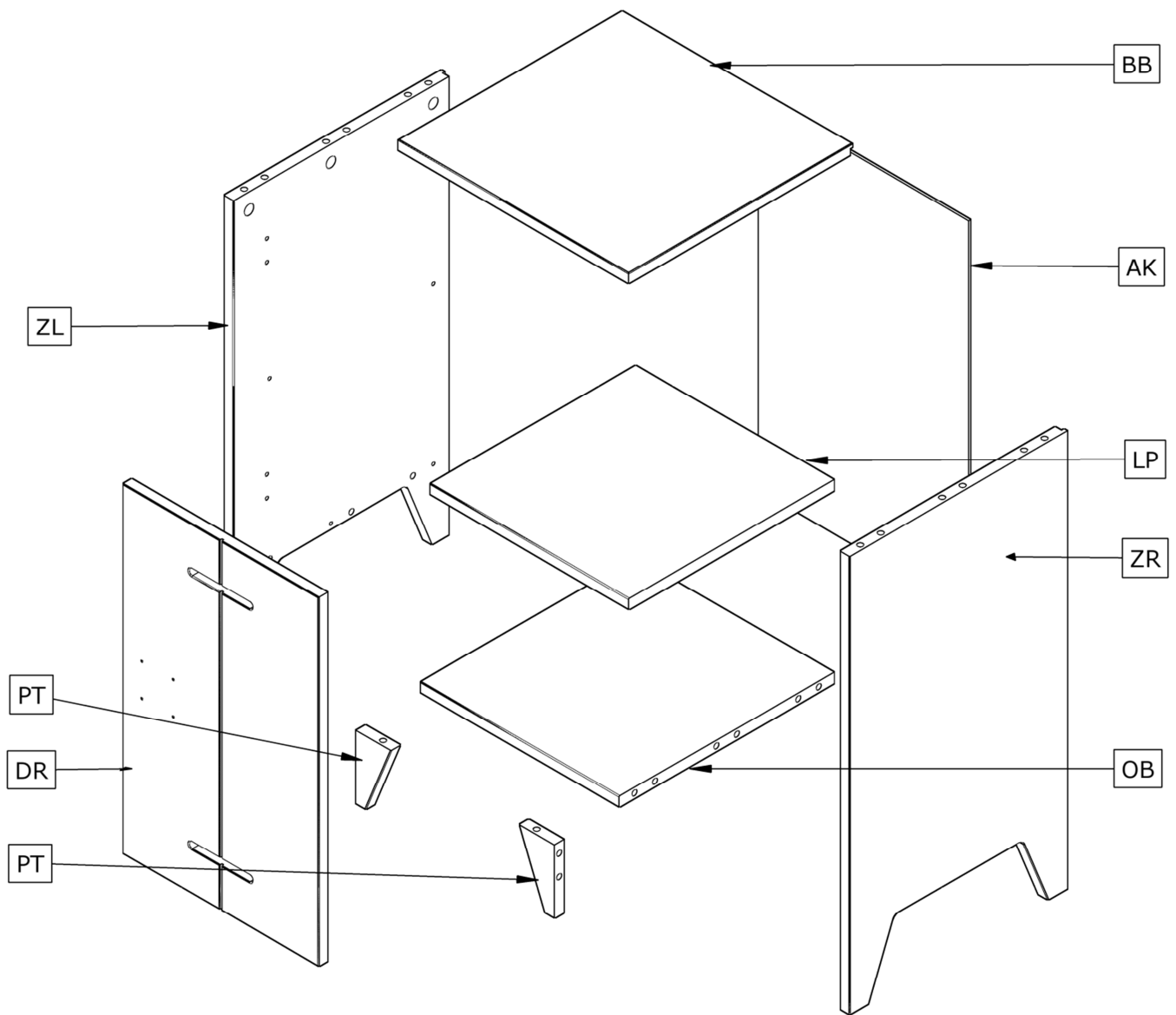

1.

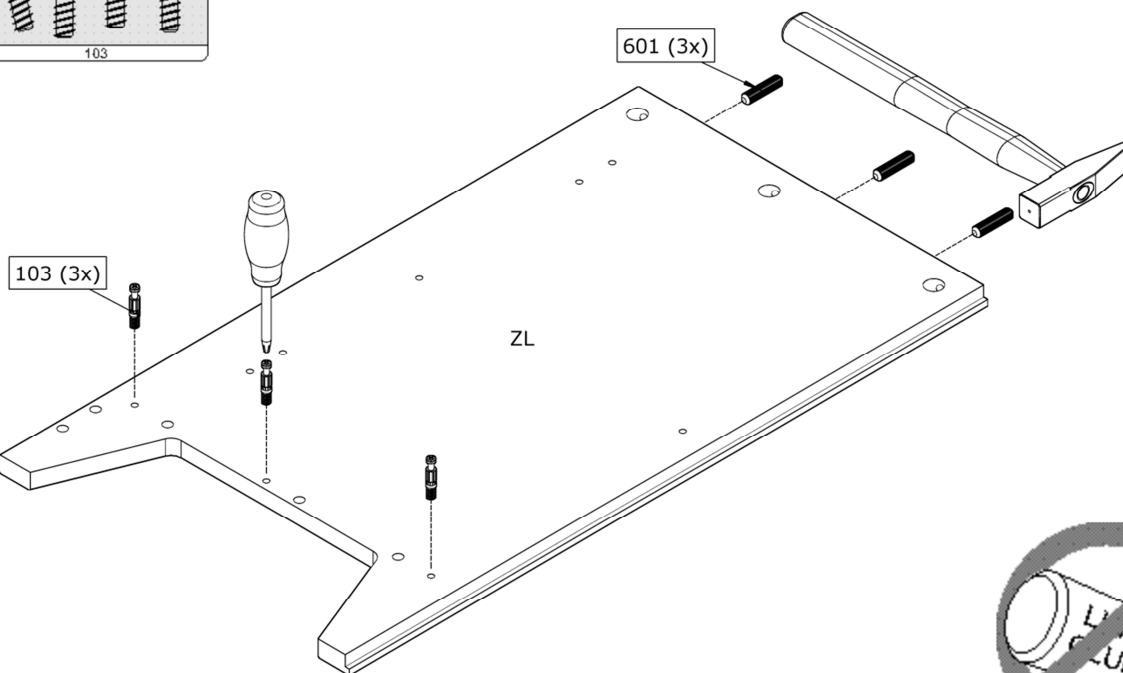
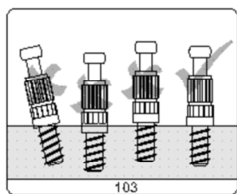

2.

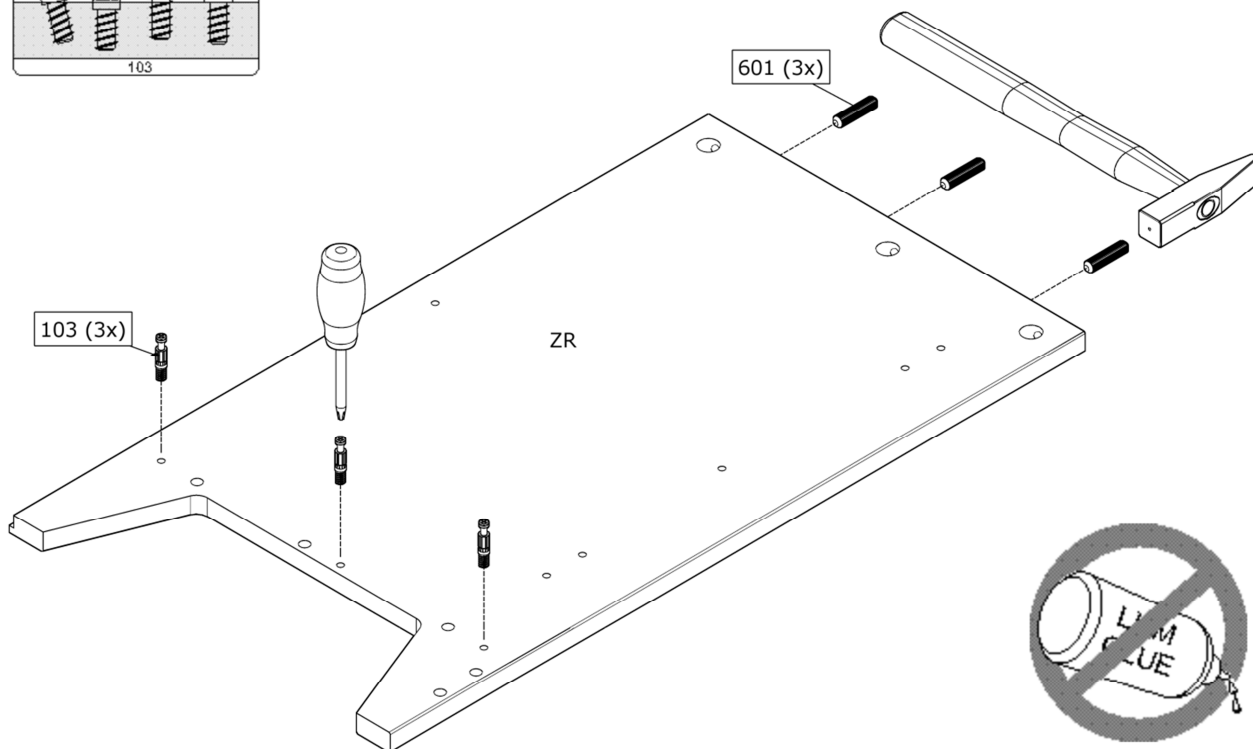
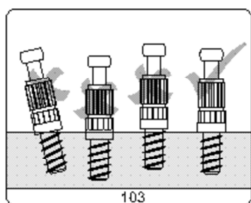

3.

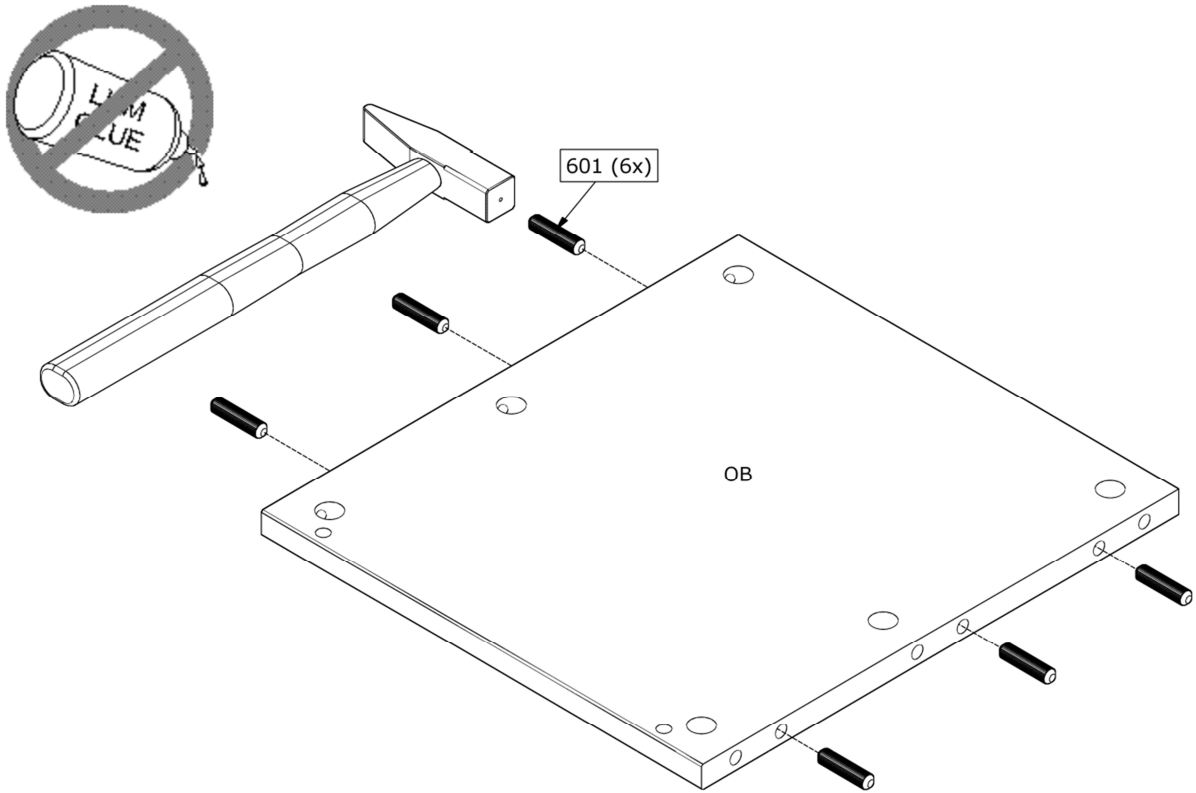

4.

Het gebruik van een beetje houtlijm (maximaal 2 druppels per boor gat ) is noodzakelijk voor een goede verbinding.  
Verwendung von ein bisschen Holzleim (bis 2 tropfen pro Bohrtloch) ist notwendig für eine gute Verbindung.  
Il est nécessaire d'utiliser un peu de colle à bois (au maximum deux gouttes pour chaque trou de perceuse) pour assurer un bon assemblage.  
The use of a little bit wood glue (up to 2 drops per drill hole) is necessary for proper connection

2x

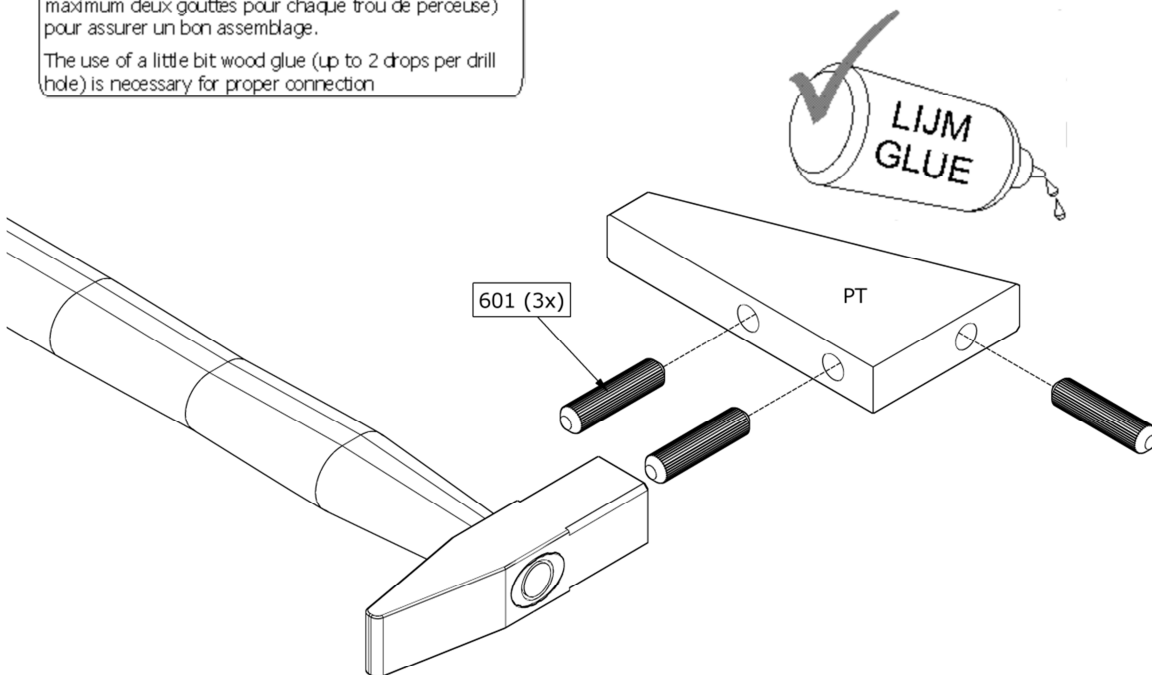

5.

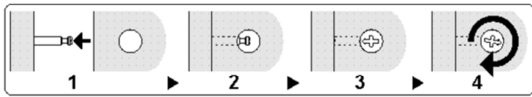

Het gebruik van een beetje houtlijm (maximaal 2 druppels per boor gat ) is noodzakelijk voor een goede verbinding.  
Verwendung von ein bisschen Holzleim (bis 2 tropfen pro Bohrloch) ist notwendig für eine gute Verbindung.  
Il est nécessaire d'utiliser un peu de colle à bois (au maximum deux gouttes pour chaque trou de perçouse) pour assurer un bon assemblage.  
The use of a little bit wood glue (up to 2 drops per drill hole) is necessary for proper connection

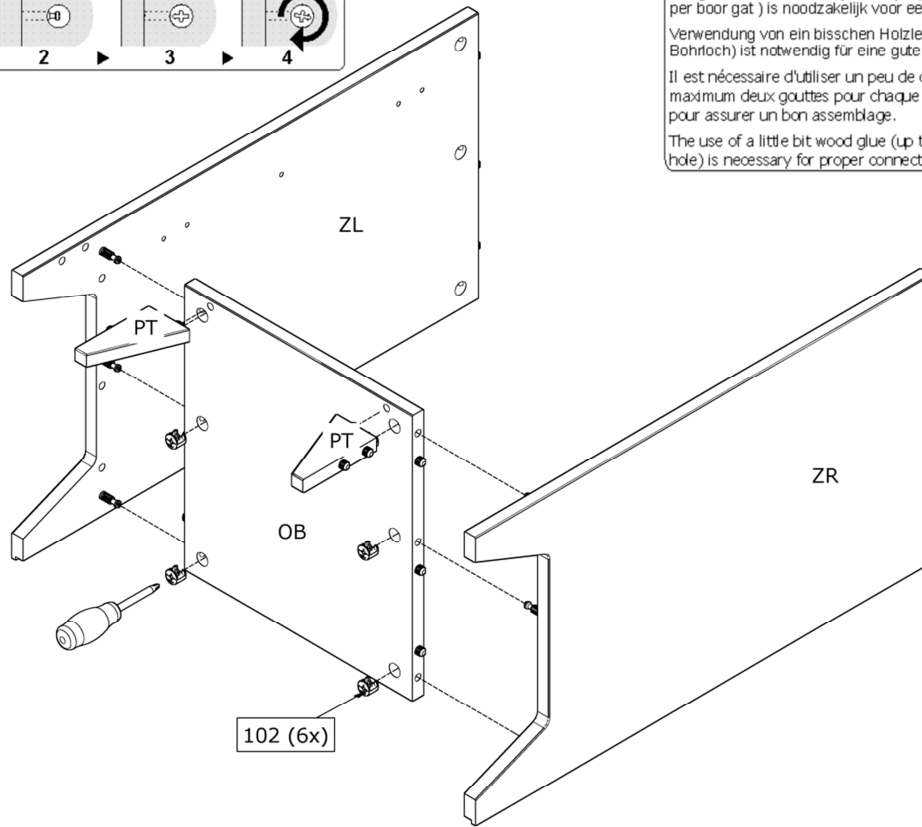

6.

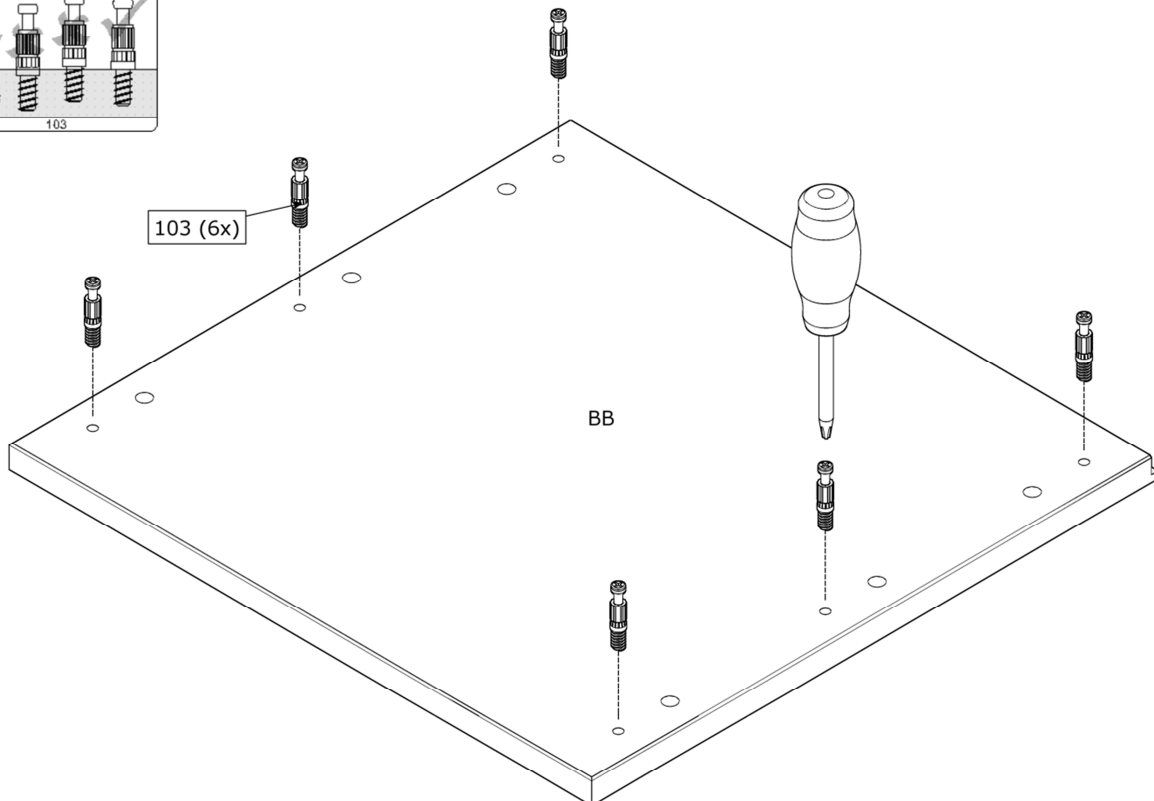
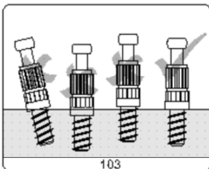

7.

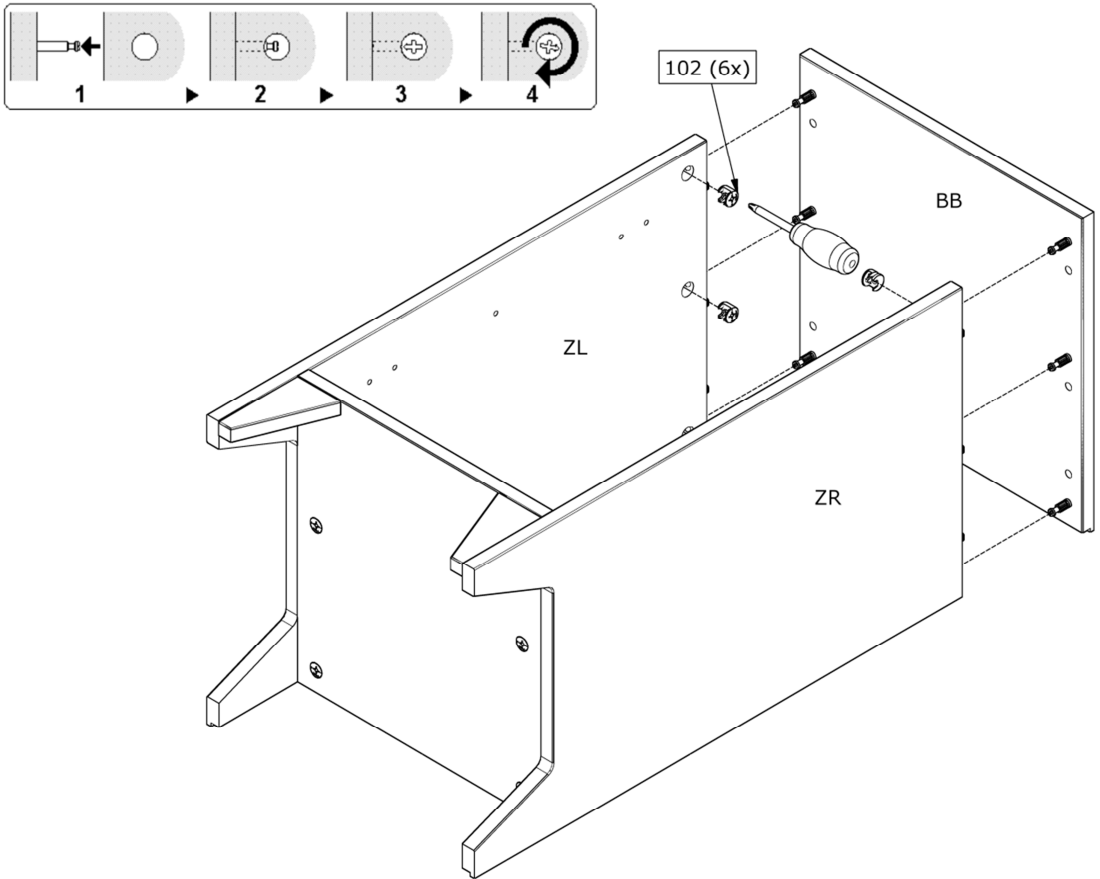

8.

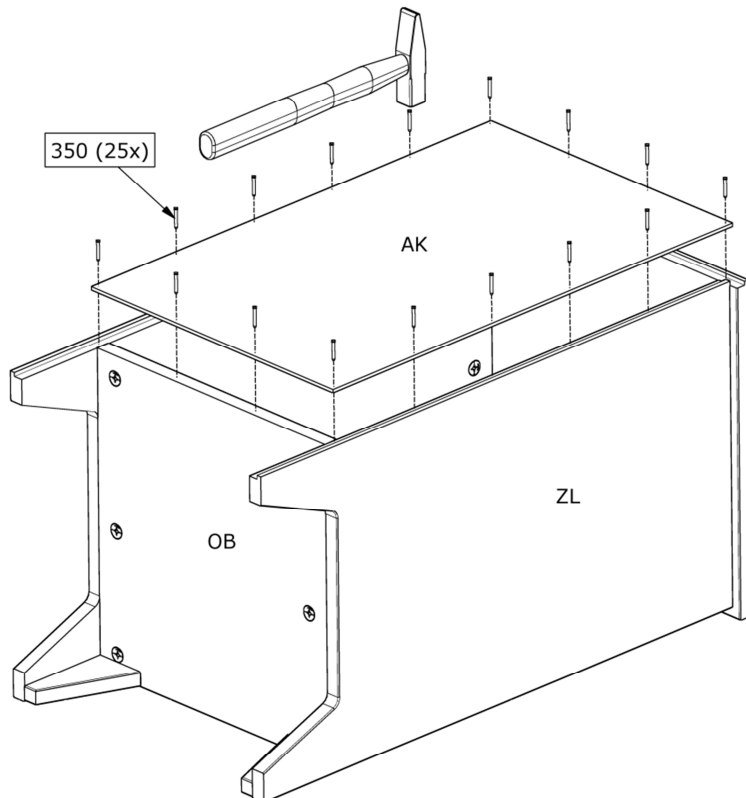

9.

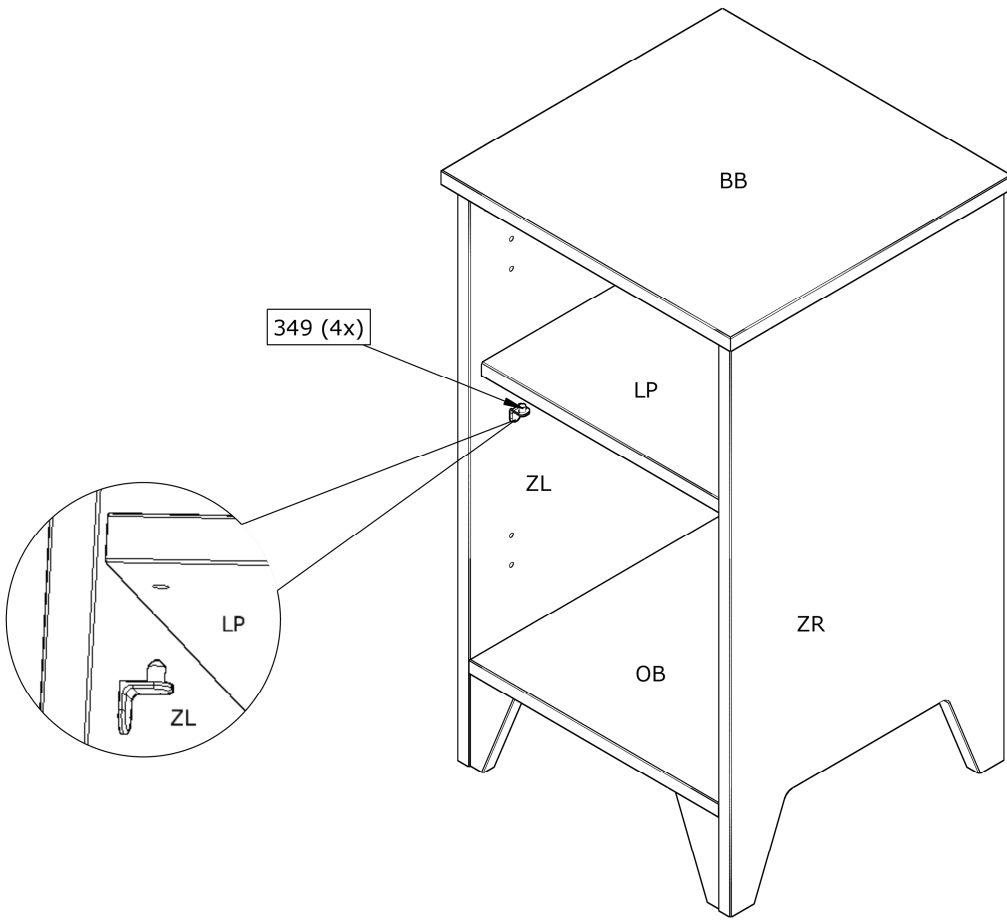

10.

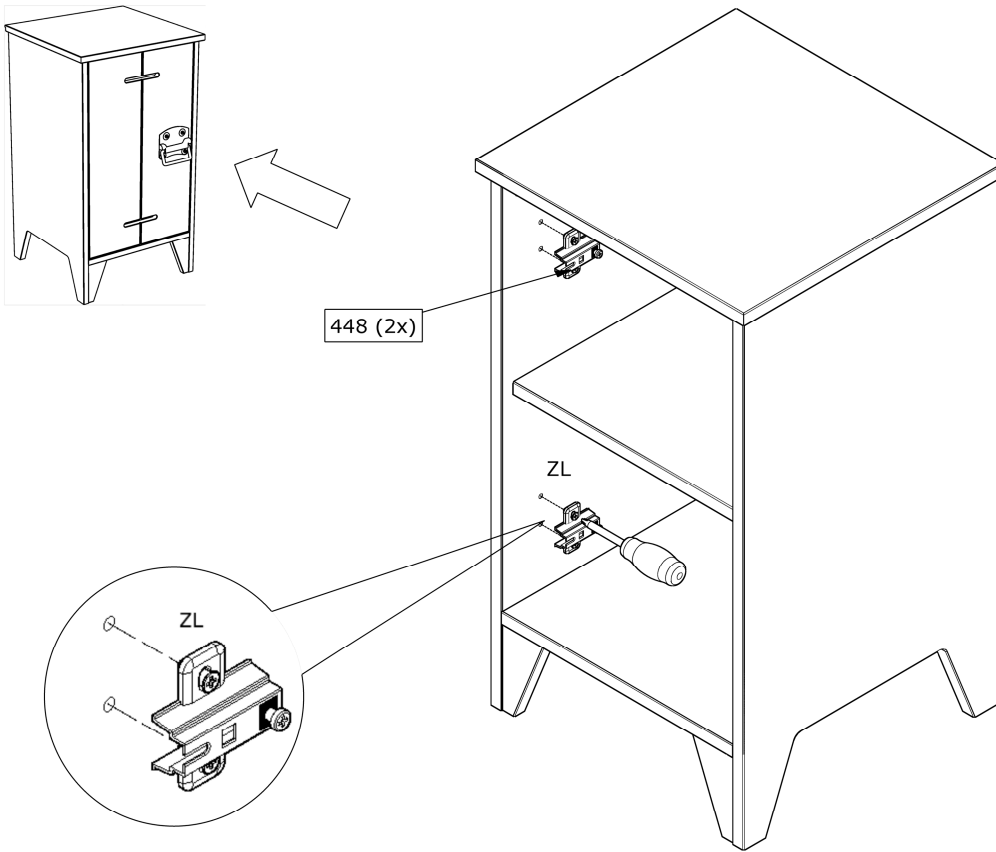

11.

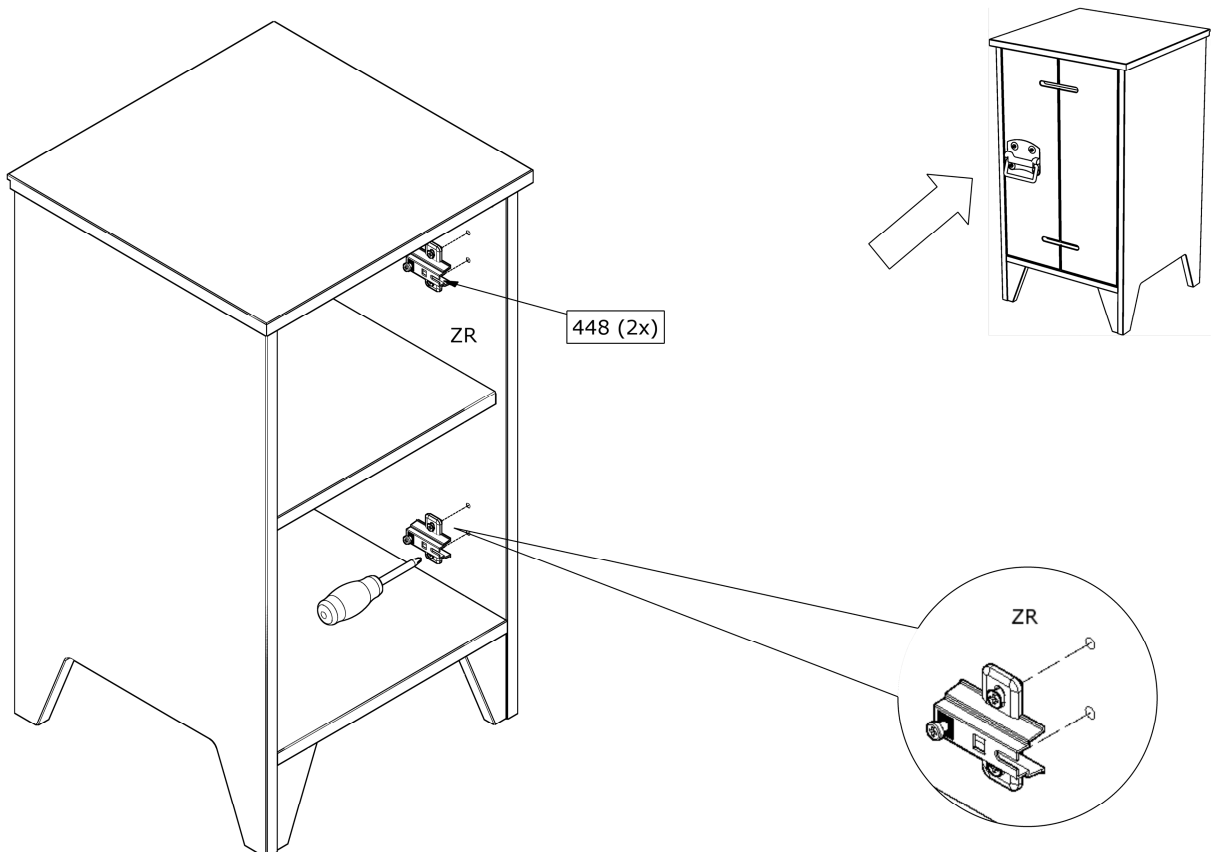

12.

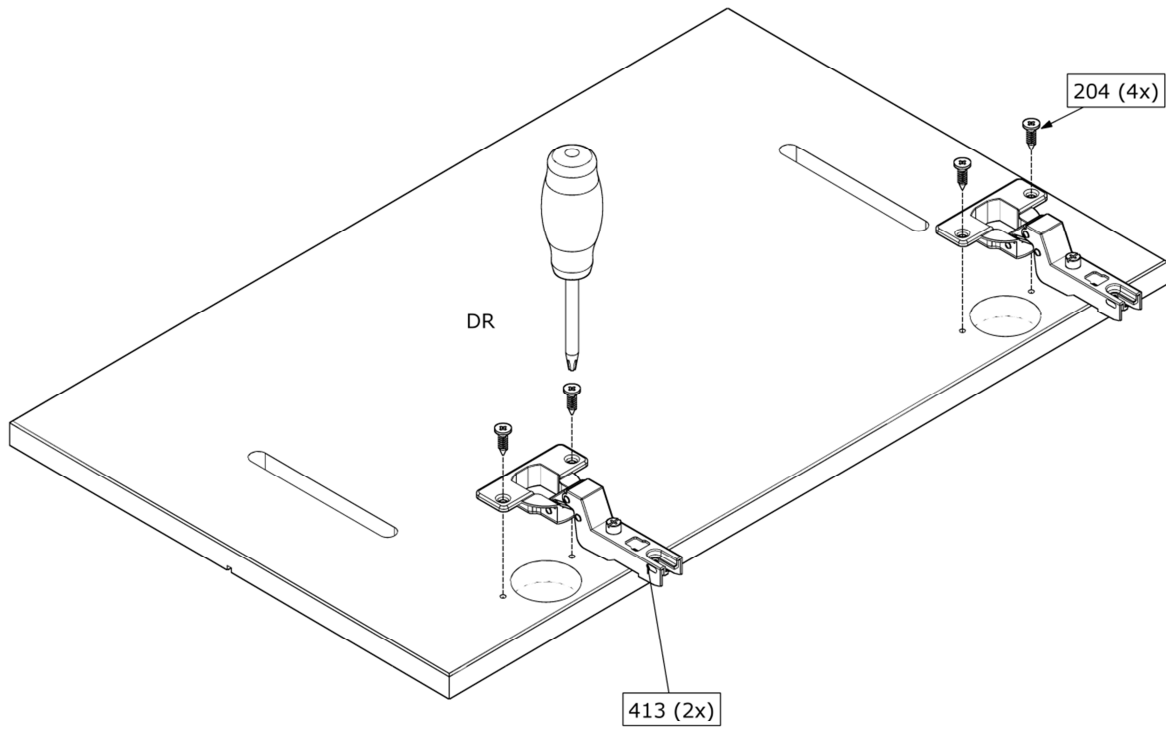

13.

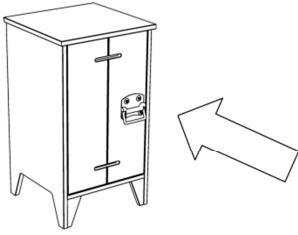

A. Deze schroef gebruiken wanneer u de kieren tussen de deuren en beide zijden groter of kleiner wilt hebben.  
 B. Door deze schroeven iets los te draaien kunt u de scharnierplaatjes verstellen zodat de deuren hoger of lager bevestigd kunnen worden.  
 C. Met deze schroef draait u de deur vast.

A. Diese Schraube benutzen, wenn der Spalt Zwischen der Tür und den Seiten größer oder kleiner sein soll.  
 B. Wenn Sie diese Schrauben ein wenig lösen, können Sie die Scharnierplatten verstellen, um so die Tür höher oder niedriger zu befestigen.  
 C. Mit dieser Schraube befestigen Sie die Tür.

A. Utilisez cette vis, si vous voulez agrandir ou réduire la fente entre la porte et les deux côtés de l'armoire.  
 B. En dévissant ces vis quelque peu, vous pouvez régler les charnières pour accrocher ensuite la porte plus haute ou plus basse.  
 C. Fixez la porte à l'aide de cette vis.

A. Adjusting this screw will position doors horizontally (changes gap between doors)  
 B. By releasing this screw the position of mounting plates of the hinges can be repositioned so that vertical position of doors can be adjusted (higher/lower)  
 C. This screw fixes the door.

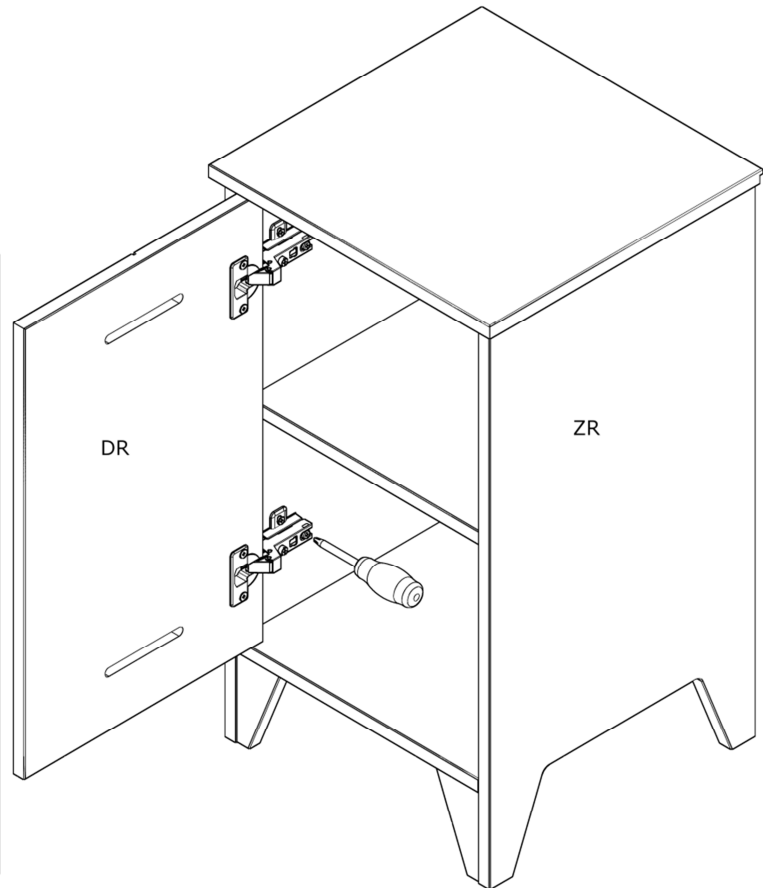
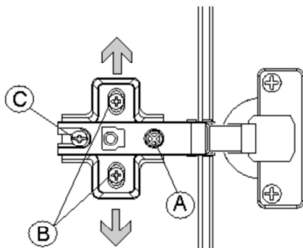

14.

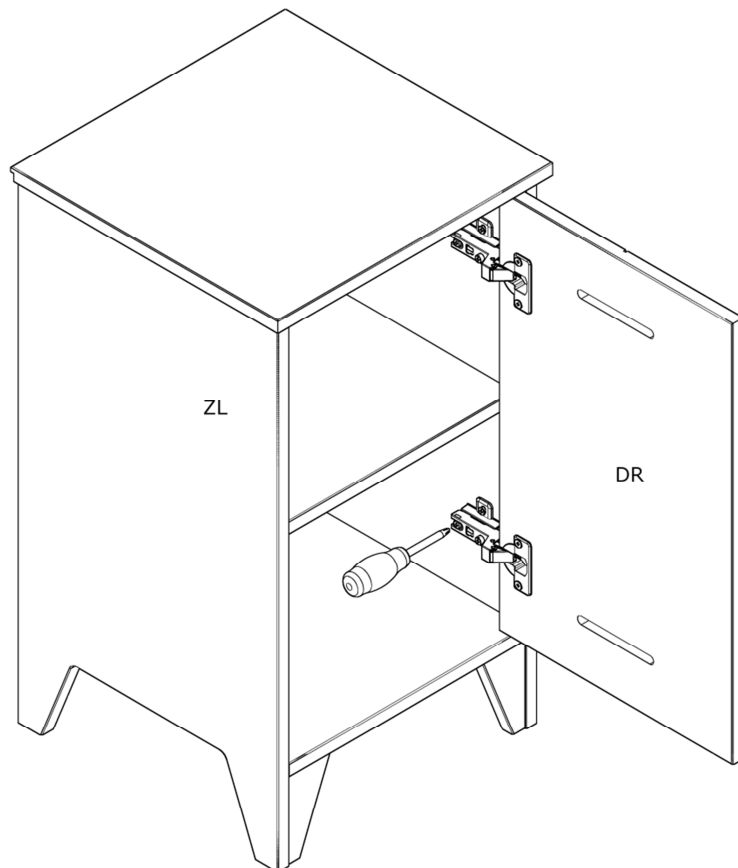
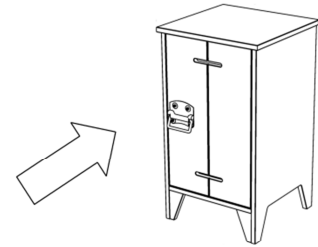

A. Deze schroef gebruiken wanneer u de kieren tussen de deuren en beide zijden groter of kleiner wilt hebben.  
 B. Door deze schroeven iets los te draaien kunt u de scharnierplaatjes verstellen zodat de deuren hoger of lager bevestigd kunnen worden.  
 C. Met deze schroef draait u de deur vast.

A. Diese Schraube benutzen, wenn der Spalt Zwischen der Tür und den Seiten größer oder kleiner sein soll.  
 B. Wenn Sie diese Schrauben ein wenig lösen, können Sie die Scharnierplatten verstellen, um so die Tür höher oder niedriger zu befestigen.  
 C. Mit dieser Schraube befestigen Sie die Tür.

A. Utilisez cette vis, si vous voulez agrandir ou réduire la fente entre la porte et les deux côtés de l'armoire.  
 B. En dévissant ces vis quelque peu, vous pouvez régler les charnières pour accrocher ensuite la porte plus haute ou plus basse.  
 C. Fixez la porte à l'aide de cette vis.

A. Adjusting this screw will position doors horizontally (changes gap between doors)  
 B. By releasing this screw the position of mounting plates of the hinges can be repositioned so that vertical position of doors can be adjusted (higher/lower)  
 C. This screw fixes the door.

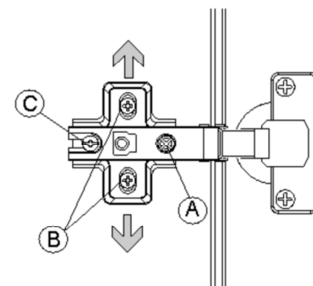

15.

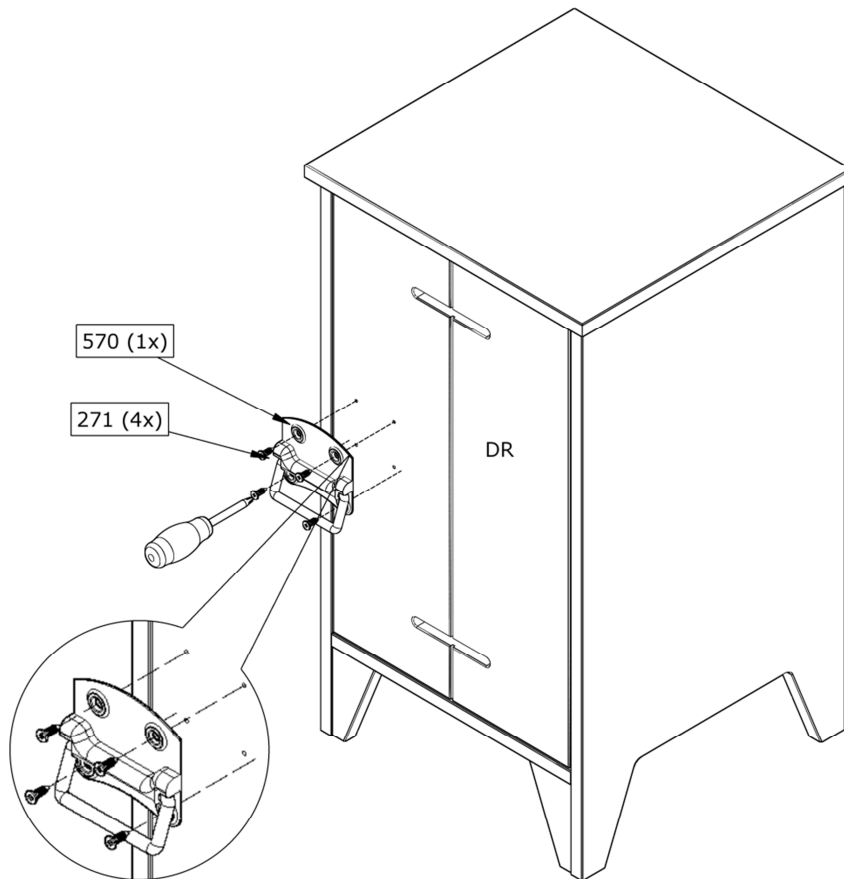

## SOCIAL MEDIA

We are curious about the result! Would you like to share it with us? Use #WOOOD on social media.

Wir sind gespannt auf das Ergebnis! Möchten Sie es mit uns teilen? Benutzen Sie #WOOOD in Social Media.

Nous sommes impatient de connaître le résultat. Souhaitez-vous le partager avec nous? Utilisez #WOOOD sur les médias sociaux.



[facebook.com/wood.nl](https://facebook.com/wood.nl)  
[twitter.com/madebywood](https://twitter.com/madebywood)  
[instagram.com/madebywood](https://instagram.com/madebywood)  
[pinterest.com/madebywood](https://pinterest.com/madebywood)