

CE EMC TEST REPORT

FOR

Applicant	:	PEAG, LLC dba JLab Audio
Address	:	5927 LANDAU CT, Carlsbad, CA 92008, United States
Equipment under Test	:	TWS Earphone
Model No.	:	JBuds Mini
Trade Mark	:	
Manufacturer	:	GuangDong SImpreal Intelligent Technology Co., Ltd.
Address	:	Room 2408, JiaHong ZhenXing DaSha, DongGuan Avenue #13, DongCheng District, DongGuan City, GuangDong Province, P. R. China

Issued By: Dongguan Dongdian Testing Service Co., Ltd.

Add.: No. 17, Zongbu Road 2, Songshan Lake Sci&Tech, Industry Park,
Dongguan City, Guangdong Province, China, 523808

Tel.: +86-0769-38826678, **E-mail:** ddt@dgddt.com, **http://**www.dgddt.com

REPORT

Table of Contents

	Test report declares	5
1.	Summary of Test Results	7
2.	General Test Information	8
2.1.	Description of EUT	8
2.2.	Primary function of EUT	8
2.3.	Port of EUT	9
2.4.	Accessories of EUT	9
2.5.	Block diagram EUT configuration for test	9
2.6.	Decision of final test mode	10
2.7.	Deviations of test standard	10
2.8.	Test environment conditions	10
2.9.	Test laboratory	10
2.10.	Measurement uncertainty	11
3.	Conducted Emission Test (mains power port)	12
3.1.	Test equipment	12
3.2.	Block diagram of test setup	12
3.3.	Limits	13
3.4.	Assistant equipment used for test	14
3.5.	Test procedure	14
3.6.	Test result	14
3.7.	Test photo	17
4.	Radiated Emissions Test	18
4.1.	Test equipment	18
4.2.	Block diagram of test setup	19
4.3.	Limits	22
4.4.	Assistant equipment used for test	22
4.5.	Test procedure	22
4.6.	Test result	23
4.7.	Test photo	28
5.	Harmonic Current and Voltage Fluctuations& Flicker Test	30
5.1.	Test equipment	30
5.2.	Block diagram of test setup	30
5.3.	Harmonic current limits	30
5.4.	Voltage fluctuations & flicker Limit	31
5.5.	Assistant equipment used for test	31
5.6.	Test procedure	32

5.7.	Test result	32
5.8.	Test photo	34
6.	Electrostatic Discharge Test	35
6.1.	Test equipment	35
6.2.	Block diagram of test setup	35
6.3.	Test levels and performance criterion	35
6.4.	Assistant equipment used for test	36
6.5.	Test procedure.....	36
6.6.	Test result	36
6.7.	Test photo	38
7.	Continuous Radio Frequency Disturbances Test.....	39
7.1.	Test equipment	39
7.2.	Block diagram of test setup	39
7.3.	Test levels and performance criterion	40
7.4.	Assistant equipment used for test	41
7.5.	Test Procedure	41
7.6.	Test result	42
7.7.	Test photo	44
8.	Electrical Fast Transients (EFT) Test.....	45
8.1.	Test equipment	45
8.2.	Block diagram of test setup	45
8.3.	Test levels and performance criterion	46
8.4.	Assistant equipment used for test	46
8.5.	Test procedure.....	47
8.6.	Test result	47
8.7.	Test photo	48
9.	Surges test.....	49
9.1.	Test equipment	49
9.2.	Block diagram of test setup	49
9.3.	Test levels and performance criterion	49
9.4.	Assistant equipment used for test	50
9.5.	Test procedure.....	50
9.6.	Test result	51
9.7.	Test photo	52
10.	Continuous Conducted Disturbances.....	53
10.1.	Test equipment	53
10.2.	Block diagram of test setup	53
10.3.	Test levels and performance criterion	54

10.4.	Assistant equipment used for test	55
10.5.	Test procedure.....	55
10.6.	Test result	56
10.7.	Test photo	57
11.	Power-Frequency Magnetic Fields.....	58
11.1.	Test equipment	58
11.2.	Block diagram of test setup	58
11.3.	Test levels and performance criterion	58
11.4.	Assistant equipment used for test	58
11.5.	Test procedure.....	59
11.6.	Test result	59
11.7.	Test photo	60
12.	Voltage Dips and Interruptions	61
12.1.	Test Equipment.....	61
12.2.	Block diagram of test setup	61
12.3.	Test levels and performance criterion	61
12.4.	Assistant equipment used for test	62
12.5.	Test Procedure	62
12.6.	Test result	62
12.7.	Test photo	63
13.	Photos of The EUT	64

Test Report Declare

Applicant	:	PEAG, LLC dba JLab Audio
Address	:	5927 LANDAU CT, Carlsbad, CA 92008, United States
Equipment under Test	:	TWS Earphone
Model No.	:	JBuds Mini
Trade Mark	:	
Manufacturer	:	GuangDong Simpreal Intelligent Technology Co., Ltd.
Address	:	Room 2408, JiaHong ZhenXing DaSha, DongGuan Avenue #13, DongCheng District, DongGuan City, GuangDong Province, P. R. China

Test Standard Used:

EN 55032:2015, EN 55032:2015/A11:2020, EN 55035:2017, EN 55035:2017/A11:2020,
EN IEC 61000-3-2:2019/A1:2021, EN 61000-3-3:2013/A2:2021

We Declare:

The equipment described above is tested by Dongguan Dongdian Testing Service Co., Ltd. and in the configuration tested the equipment complied with the standards specified above. The test results are contained in this test report and Dongguan Dongdian Testing Service Co., Ltd. is assumed of full responsibility for the accuracy and completeness of these tests.

After test and evaluation, our opinion is that the equipment in accordance with above standards about the electromagnetic compatibility requirements of EMC Directive 2014/30/EU.

Report No.:	DDT-RE23051012-1E01		
Date of Receipt:	May 12, 2023	Date of Test:	May 16, 2023 ~ Jun. 09, 2023



Prepared By:

Harmony Zeng

Harmony Zeng /Engineer

Approved By:



Damon Hu/EMC Manager

Note: This report applies to above tested sample only. This report shall not be reproduced in parts without written approval of Dongguan Dongdian Testing Service Co., Ltd.

Revision History

Rev.	Revisions	Issue Date	Revised By
---	Initial issue	Jun. 17, 2023	

1. Summary of Test Results

EMISSION (EMI)		
Description of Test Item	Standard	Result
Conducted disturbance at mains terminals	EN 55032:2015, EN 55032:2015/A11:2020	PASS
Asymmetric mode conducted emissions	EN 55032:2015, EN 55032:2015/A11:2020	N/A
Conducted differential voltage emissions	EN 55032:2015, EN 55032:2015/A11:2020	N/A
Radiated disturbance	EN 55032:2015, EN 55032:2015/A11:2020	PASS
Harmonic current emissions	EN IEC 61000-3-2:2019/A1:2021	N/A
Voltage fluctuations & flicker	EN 61000-3-3:2013/A2:2021	PASS
IMMUNITY (EMS)		
Description of Test Item	Standard	Results
Electrostatic discharge (ESD)	EN 55035:2017, EN 55035:2017/A11:2020	PASS
Continuous radio frequency disturbances	EN 55035:2017, EN 55035:2017/A11:2020	PASS
Electrical fast transients (EFT)	EN 55035:2017, EN 55035:2017/A11:2020	PASS
Surges	EN 55035:2017, EN 55035:2017/A11:2020	PASS
Continuous conducted disturbances	EN 55035:2017, EN 55035:2017/A11:2020	PASS
Power-frequency magnetic fields	EN 55035:2017, EN 55035:2017/A11:2020	PASS
Voltage dips and interruptions	EN 55035:2017, EN 55035:2017/A11:2020	PASS
Note: N/A is an abbreviation for Not Applicable, and means this item is not applicable for this device or no need to test according to standard.		

Note: 1. The EMI measurements had been made in the operating mode producing the largest emission in the frequency band being investigated consistent with normal applications. An attempt had been made to maximize the emission by varying the configuration of the EUT.

2. The EMS measurements had been made in the frequency bands being investigated, with the EUT in the most susceptible operating mode consistent with normal applications. The configuration of the test sample had been varied to achieve maximum susceptibility.

2. General Test Information

2.1. Description of EUT

EUT Name	: TWS Earphone
Model Number	: JBuds Mini
EUT Function Description	: Please reference user manual of this device
Power supply	: Case: DC 5V by external adapter and DC 3.8V built-in battery
	: Earbud: DC 5V by charging case and DC 3.85V built-in battery
EUT Class (Only For EMI)	: <input type="checkbox"/> Class A, <input checked="" type="checkbox"/> Class B
Maximum Work Frequency	: 2480 MHz
Sample Type	: Series production
Sample Number	: S23051012-01

Note 1: EUT is the abbreviation of equipment under test.

Note 2: “” means to be chosen or applicable; “” means don't to be chosen or not applicable;

This note applies to entire report.

Note 3: Equipment meeting Class A requirements may not offer adequate protection to broadcast services within a residential environment; The Class B requirements for equipment are intended to offer adequate protection to broadcast services within the residential environment. Equipment compliant with the class A requirements of standard EN 55032 should have a warning notice in the user manual stating that it could cause radio interference. For example, Warning: Operation of this equipment in a residential environment could cause radio interference.

2.2. Primary function of EUT

Function	Description
<input type="checkbox"/> Broadcast reception function	N/A
<input type="checkbox"/> Print	N/A
<input type="checkbox"/> Scan	N/A
<input type="checkbox"/> Display and display output	N/A
<input type="checkbox"/> Musical tone generating	N/A
<input type="checkbox"/> Networking	N/A
<input checked="" type="checkbox"/> Audio output	On-era devices
<input type="checkbox"/> Telephony	N/A
<input checked="" type="checkbox"/> Bluetooth	Bluetooth function
<input type="checkbox"/> Other:	N/A

2.3. Port of EUT

Port	Description
<input type="checkbox"/> AC mains power port	N/A
<input type="checkbox"/> DC network power port	N/A
<input type="checkbox"/> Wired network port	N/A
<input type="checkbox"/> Signal data/control port	N/A
<input type="checkbox"/> Antenna port	N/A
<input type="checkbox"/> Audio input port	N/A
<input type="checkbox"/> Video input port	N/A
<input type="checkbox"/> Audio output port	N/A
<input type="checkbox"/> Video output port	N/A
<input checked="" type="checkbox"/> Other: DC port	Powered by AC/DC power converter port

2.4. Accessories of EUT

Accessories	Manufacturer	Model number	Description
N/A	N/A	N/A	N/A

2.5. Block diagram EUT configuration for test

For mode 1: Charging mode



For mode 2: Case charging mode

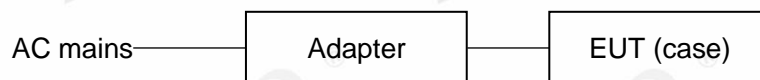

For mode 3: Earbud charging mode

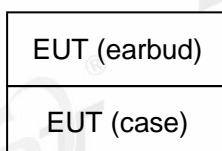

2.6. Decision of final test mode

Accordinging pre-test, the worst test modes were reported as below.

Emission	Conducted Emission (Mains Port)	Mode 1: Charging mode
	Radiated emission	Mode 1: Charging mode
	Voltage fluctuations & flicker	Mode 1: Charging mode
Immunity	Electrostatic discharge	Mode 1: Charging mode Mode 2: Case charging mode Mode 3: Earbud charging mode
	Continuous radio frequency disturbances	Mode 1: Charging mode Mode 2: Case charging mode Mode 3: Earbud charging mode
	Electrical fast transients	Mode 1: Charging mode Mode 2: Case charging mode
	Surges	Mode 1: Charging mode Mode 2: Case charging mode
	Continuous conducted disturbances	Mode 1: Charging mode Mode 2: Case charging mode
	Power-frequency magnetic fields	Mode 1: Charging mode Mode 2: Case charging mode Mode 3: Earbud charging mode
	Voltage dips and interruptions	Mode 1: Charging mode Mode 2: Case charging mode

2.7. Deviations of test standard

No deviation.

2.8. Test environment conditions

During the measurement the environmental conditions were within the listed ranges:

Temperature range:	20-25°C
Humidity range:	40-75%
Pressure range:	86-106 kPa

Note: The specific temperature and humidity information of each test item refers to the temperature and humidity record in the corresponding test data.

2.9. Test laboratory

Dongguan Dongdian Testing Service Co., Ltd.

Add.: No. 17, Zongbu Road 2, Songshan Lake Sci&Tech, Industry Park, Dongguan City, Guangdong Province, China, 523808.

Tel.: +86-0769-38826678, <http://www.dgddt.com>, Email: ddt@dgddt.com.

CNAS Accreditation No. L6451; A2LA Accreditation Number: 3870.01

FCC Designation Number: CN1182, Test Firm Registration Number: 540522

Innovation, Science and Economic Development Canada Site Registration Number: 10288A

Conformity Assessment Body identifier: CN0048

VCCI facility registration number: C-20087, T-20088, R-20123, R-20155, G-20118

2.10. Measurement uncertainty

Test Item	Uncertainty
Conducted disturbance at mains terminals	1#: 3.72dB (9 kHz to 150 kHz), 3.34dB (150 kHz to 30 MHz)
	2#: 3.75dB (9 kHz to 150 kHz), 3.39dB (150 kHz to 30 MHz)
	3#: 3.78dB (9 kHz to 150 kHz), 3.37dB (150 kHz to 30 MHz)
Uncertainty for telecommunication port conduction emission test	1#: AAN with aLCL = 55 ... 40 dBc: 3.64 dB AAN with aLCL = 65 ... 50 dBc: 4.08 dB AAN with aLCL = 75 ... 60 dBc: 4.56 dB
	2#: AAN with aLCL = 55 ... 40 dBc: 3.82 dB AAN with aLCL = 65 ... 50 dBc: 3.96 dB AAN with aLCL = 75 ... 60 dBc: 4.12 dB
Uncertainty for radiation emission test (30 MHz-1 GHz)	1#: 4.94 dB (Antenna Polarize: V) 4.68 dB (Antenna Polarize: H)
	2#: 4.94 dB (Antenna Polarize: V) 4.68 dB (Antenna Polarize: H)
	3#: 4.96 dB (Antenna Polarize: V) 4.98 dB (Antenna Polarize: H)
	10m: 4.48 dB (Antenna Polarize: V) 4.64 dB (Antenna Polarize: H)
Uncertainty for radiation disturbance test (1 GHz to 6 GHz)	1#: 4.10 dB (1-6 GHz)
	3#: 4.54 dB (1-6 GHz)
Uncertainty for Flicker test	0.2%
Uncertainty for Harmonic test	5%
Uncertainty for Electrostatic discharge	Rise time: 4% Peak current: 3.1% Current at 30 ns: 3.1% Current at 60 ns: 3.1%
Uncertainty for Surge	Peak of the open-circuit voltage impulse: 3% Front time of the open-circuit voltage impulse: 5% Width of the open-circuit voltage impulse: 5% Peak of the short-circuit current impulse: 2.7% Front time of the short-circuit current impulse: 5% Duration of the short-circuit current impulse: 3%
Uncertainty for Electrical fast transients	Voltage rise time: 3.7% Peak voltage value: 3.4% Voltage pulse width: 3.7%
Uncertainty for Continuous conducted disturbances	0.25dB
Uncertainty for Continuous radio frequency disturbances	1.12dB
Uncertainty for Power-frequency magnetic fields	10%
Uncertainty for Voltage dips and interruptions	3.7%
Temperature	0.4 °C
Humidity	2%
Note: This uncertainty represents an expanded uncertainty expressed at approximately the 95% confidence level using a coverage factor of k=2.	

3. Conducted Emission Test (mains power port)

3.1. Test equipment

Equipment	Manufacturer	Model No.	Serial No.	Last Cal.	Cal. Interval
<input checked="" type="checkbox"/> 1# Conducted emission					
Test Receiver	R&S	ESCI	100551	Aug. 26, 2022	1 Year
LISN 1	R&S	ENV216	101109	Aug. 26, 2022	1 Year
LISN 2	R&S	ESH2-Z5	100309	Aug. 26, 2022	1 Year
Pulse Limiter	R&S	ESH3-Z2	101242	Aug. 26, 2022	1 Year
CE Cable 1	HUBSER	N/A	W10.01	Aug. 26, 2022	1 Year
Test software	Audix	E3	V 6.11111b	N/A	N/A
<input type="checkbox"/> 2# Conducted emission					
Test Receiver	R&S	ESCI	101032	Apr. 23, 2023	1 Year
LISN 1	R&S	ENV216	101170	Aug. 26, 2022	1 Year
LISN 2	R&S	ENV216	101209	Aug. 26, 2022	1 Year
Pulse Limiter	R&S	KH43101	4310118015 68-12#	May 05, 2023	1 Year
CE Cable 2	HUBSER	RG214-5	N/A	Apr. 27, 2023	1 Year
Test software	Audix	E3	V 6.11111b	N/A	N/A
<input type="checkbox"/> 3# Conducted emission					
Test Receiver	R&S	ESCI	101028	Aug. 26, 2022	1 Year
LISN 1	R&S	ENV216	101725	Aug. 26, 2022	1 Year
LISN 2	R&S	ENV216	101726	Aug. 26, 2022	1 Year
LISN 3	SCHWARZBECK	NSLK 8163	00017	Aug. 26, 2022	1 Year
Pulse Limiter	SCHWARZBECK	VTSD 9561	102766	Aug. 26, 2022	1 Year
CE Cable 3	HUBSER	Z806-NJ-NJ-6M	21070275	Aug. 26, 2022	1 Year
Test software	Audix	E3	V 6.11111b	N/A	N/A
Notes. N/A means Not applicable.					

3.2. Block diagram of test setup

For table-top equipment

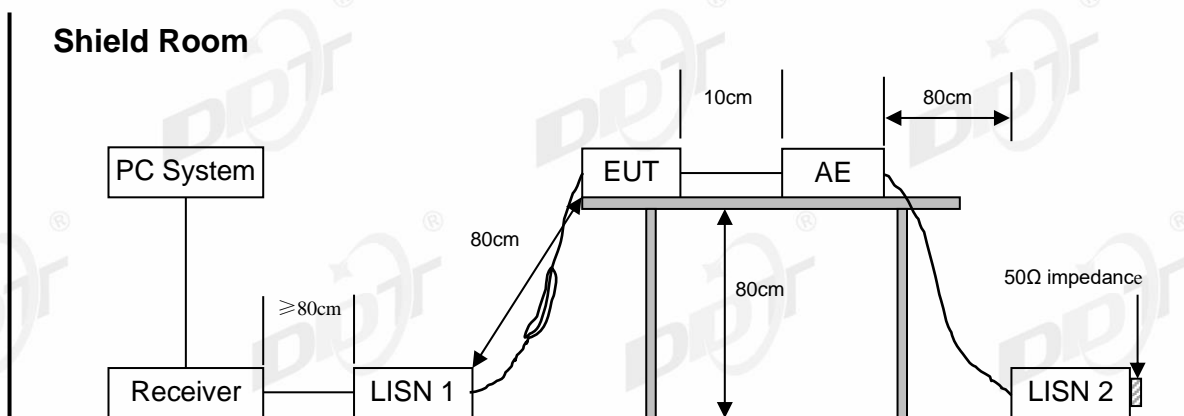

For floor standing equipment

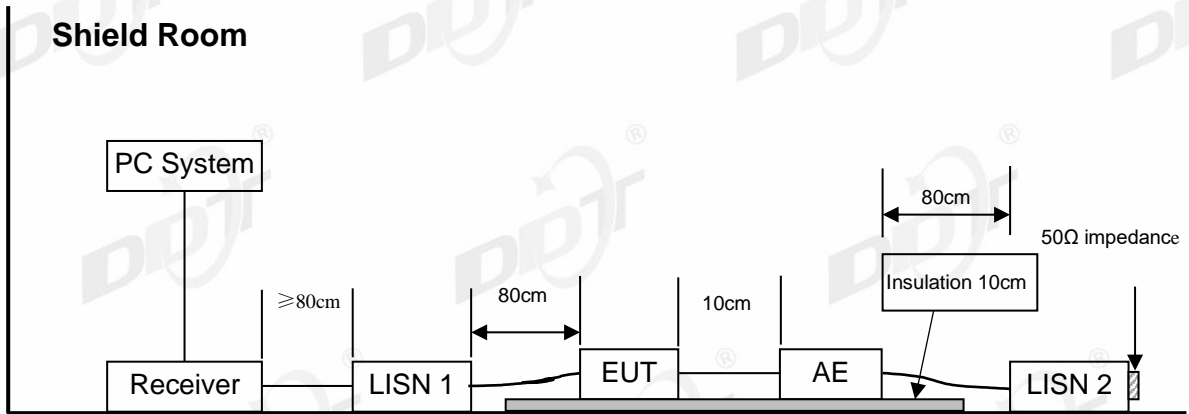

For combinations equipment

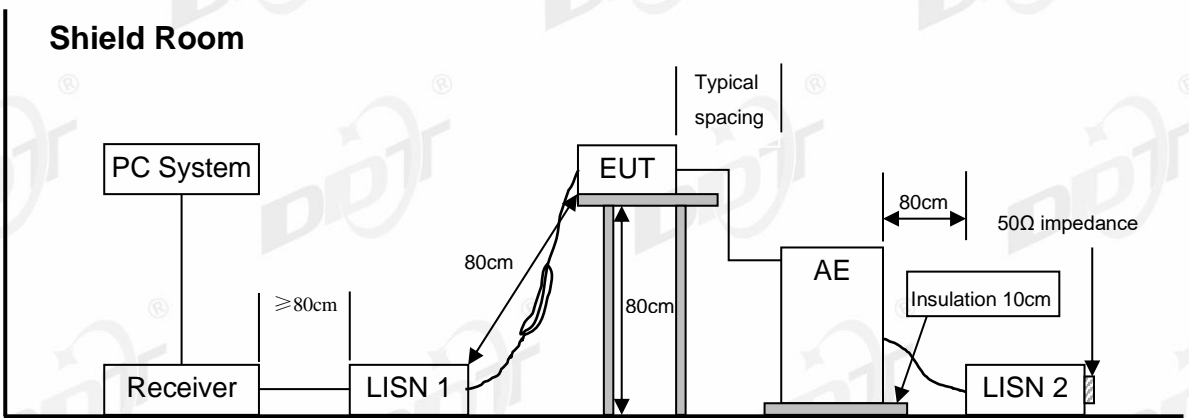

3.3. Limits

Class A

Frequency	Quasi-Peak Level dB(μV)	Average Level dB(μV)
150 kHz ~ 500 kHz	79	66
500 kHz ~ 30 MHz	73	60

Class B

Frequency	Quasi-Peak Level dB(μV)	Average Level dB(μV)
150 kHz ~ 500 kHz	66 ~ 56*	56 ~ 46*
500 kHz ~ 5 MHz	56	46
5 MHz ~ 30 MHz	60	50

Notes: 1. * Decreasing linearly with logarithm of frequency.

2. The lower limit shall apply at the transition frequencies.

3.4. Assistant equipment used for test

Assistant equipment	Manufacturer	Model number	Description	other
Adapter	HUAWEI	HW-100400C01 JB91L6L7S04031	Input: 100-240V~ 50/60Hz, Output: 5V/2A or 9V/2A or 10V/4A MAX	N/A
USB cable	N/A	N/A	Length: 1.00m, Unshielded	N/A

3.5. Test procedure

- (1) The EUT was placed on a non-metallic table, 0.8m (table-top device)/0.1m (floor-stand device) above the ground plane.
- (2) Setup the EUT and assistant equipment as shown above block diagram and equipment list.
- (3) The EUT's power adapter was connected to the power mains through a line impedance stabilization network (L.I.S.N). which this provided a 50-ohm coupling impedance for the EUT (Please refer to the block diagram of the test setup and photographs). Both sides of power line were checked for maximum conducted disturbance. In order to find the maximum emission, the relative positions of equipment and all of the interface cables were changed according to EN 55032 on conducted disturbance emission test.
- (4) The bandwidth of test receiver is set at 9 kHz.
- (5) The frequency range from 150 kHz to 30 MHz is checked.

3.6. Test result

PASS. (See below detailed test result)

Note 1: All emissions not reported below are too low against the prescribed limits.

Note 2: "----" means Peak detection; "----" means Average detection.

TR-4-E-010 Conducted Emission Test Result

Test Site : DDT 1# Shield Room **D:\2023 CE report data\Q23051012-1E\20230516 CE.EM6**
Test Date : 2023-05-16 **Tested By** : Jason
EUT : TWS Earphone **Model Number** : JBuds Mini
Power Supply : AC 230V/50Hz **Test Mode** : Charging mode
Condition : TEMP:24.3°C, RH:60.4%, BP:101.0kPa **LISN** : 2022 1# ENV216/NEUTRAL
Memo :

Data: 2

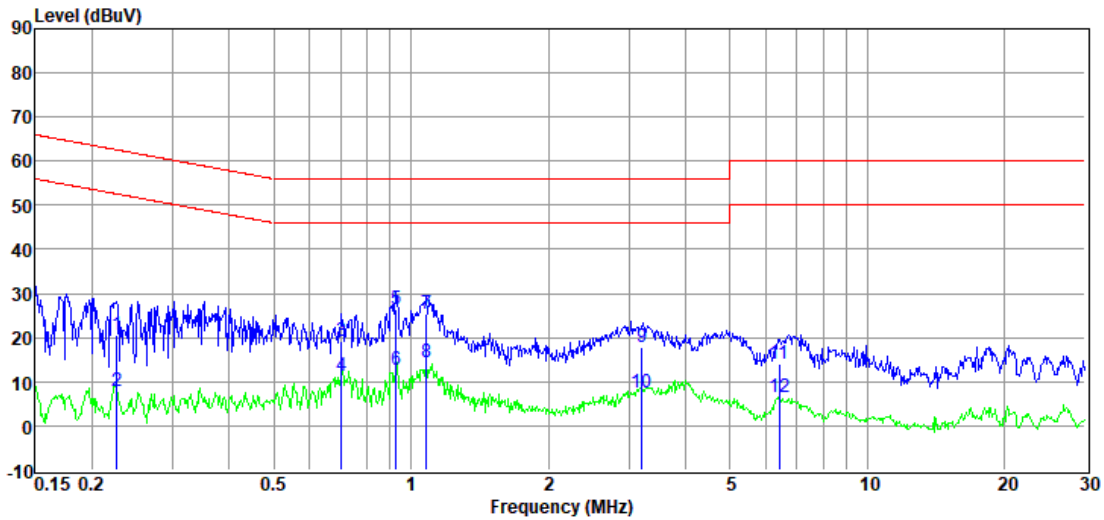

Item (Mark)	Freq. (MHz)	Read Level (dBuV)	LISN Factor (dB)	Cable Loss (dB)	Pulse Limiter Factor (dB)	Result Level (dBuV)	Limit Line (dBuV)	Over Limit (dB)	Detector	Phase
1	0.23	0.69	9.86	0.01	9.90	20.46	62.57	-42.11	QP	NEUTRAL
2	0.23	-11.74	9.86	0.01	9.90	8.03	52.57	-44.54	Average	NEUTRAL
3	0.70	-0.43	9.80	0.01	9.92	19.30	56.00	-36.70	QP	NEUTRAL
4	0.70	-8.47	9.80	0.01	9.92	11.26	46.00	-34.74	Average	NEUTRAL
5	0.93	6.83	9.72	0.02	9.91	26.48	56.00	-29.52	QP	NEUTRAL
6	0.93	-6.83	9.72	0.02	9.91	12.82	46.00	-33.18	Average	NEUTRAL
7	1.08	5.64	9.70	0.02	9.91	25.27	56.00	-30.73	QP	NEUTRAL
8	1.08	-5.40	9.70	0.02	9.91	14.23	46.00	-31.77	Average	NEUTRAL
9	3.21	-1.66	9.70	0.04	9.91	17.99	56.00	-38.01	QP	NEUTRAL
10	3.21	-12.13	9.70	0.04	9.91	7.52	46.00	-38.48	Average	NEUTRAL
11	6.42	-5.65	9.62	0.06	9.92	13.95	60.00	-46.05	QP	NEUTRAL
12	6.42	-13.25	9.62	0.06	9.92	6.35	50.00	-43.65	Average	NEUTRAL

Note:

1. Result Level = Read Level + LISN Factor + Pulse Limiter Factor + Cable loss.
2. If QP Result complies with AV limit, AV Result is deemed to comply with AV limit.
3. Test setup: RBW: 200 Hz (9 kHz—150 kHz), 9 kHz (150 kHz—30 MHz).
4. Step size: 80Hz (0.009MHz-0.15MHz), 4 kHz (0.15MHz-30MHz), Scan time: auto.

TR-4-E-010 Conducted Emission Test Result

Test Site : DDT 1# Shield Room **D:\2023 CE report data\Q23051012-1E\20230516 CE.EM6**
Test Date : 2023-05-16 **Tested By** : Jason
EUT : TWS Earphone **Model Number** : JBuds Mini
Power Supply : AC 230V/50Hz **Test Mode** : Charging mode
Condition : TEMP:24.3°C, RH:60.4%, BP:101.0kPa **LISN** : 2022 1# ENV216/LINE
Memo :

Data: 4

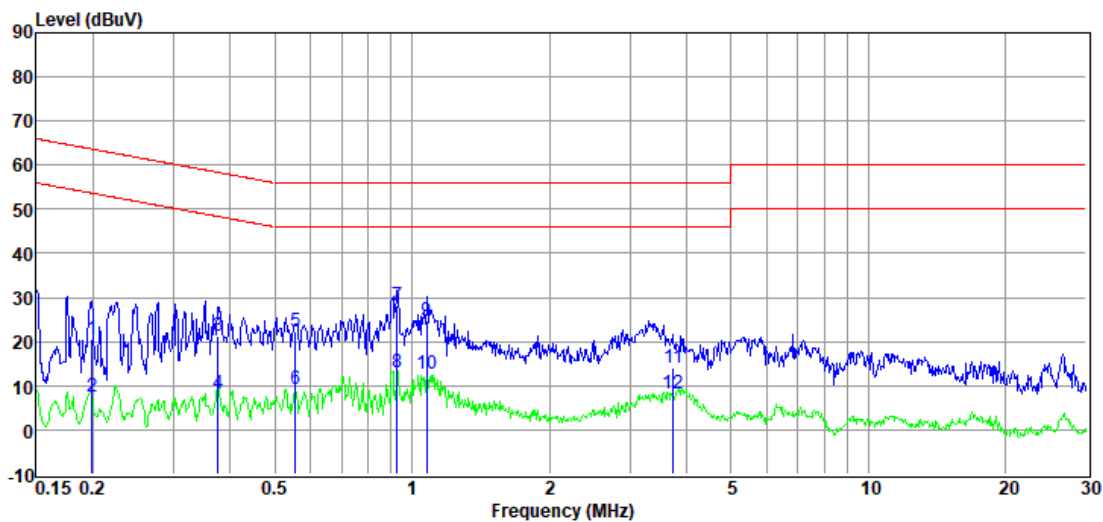

Item (Mark)	Freq. (MHz)	Read Level (dBμV)	LISN Factor (dB)	Cable Loss (dB)	Pulse Limiter Factor (dB)	Result Level (dBμV)	Limit Line (dBμV)	Over Limit (dB)	Detector	Phase
1	0.20	1.01	9.80	0.01	9.90	20.72	63.67	-42.95	QP	LINE
2	0.20	-12.26	9.80	0.01	9.90	7.45	53.67	-46.22	Average	LINE
3	0.38	1.48	9.73	0.01	9.91	21.13	58.39	-37.26	QP	LINE
4	0.38	-11.45	9.73	0.01	9.91	8.20	48.39	-40.19	Average	LINE
5	0.56	2.77	9.67	0.01	9.92	22.37	56.00	-33.63	QP	LINE
6	0.56	-10.29	9.67	0.01	9.92	9.31	46.00	-36.69	Average	LINE
7	0.93	8.72	9.52	0.02	9.91	28.17	56.00	-27.83	QP	LINE
8	0.93	-6.48	9.52	0.02	9.91	12.97	46.00	-33.03	Average	LINE
9	1.08	5.27	9.51	0.02	9.91	24.71	56.00	-31.29	QP	LINE
10	1.08	-6.70	9.51	0.02	9.91	12.74	46.00	-33.26	Average	LINE
11	3.74	-5.39	9.51	0.04	9.91	14.07	56.00	-41.93	QP	LINE
12	3.74	-11.36	9.51	0.04	9.91	8.10	46.00	-37.90	Average	LINE

Note:

1. Result Level = Read Level + LISN Factor + Pulse Limiter Factor + Cable loss.
2. If QP Result complies with AV limit, AV Result is deemed to comply with AV limit.
3. Test setup: RBW: 200 Hz (9 kHz—150 kHz), 9 kHz (150 kHz—30 MHz).
4. Step size: 80Hz (0.009MHz-0.15MHz), 4 kHz (0.15MHz-30MHz), Scan time: auto.

3.7. Test photo

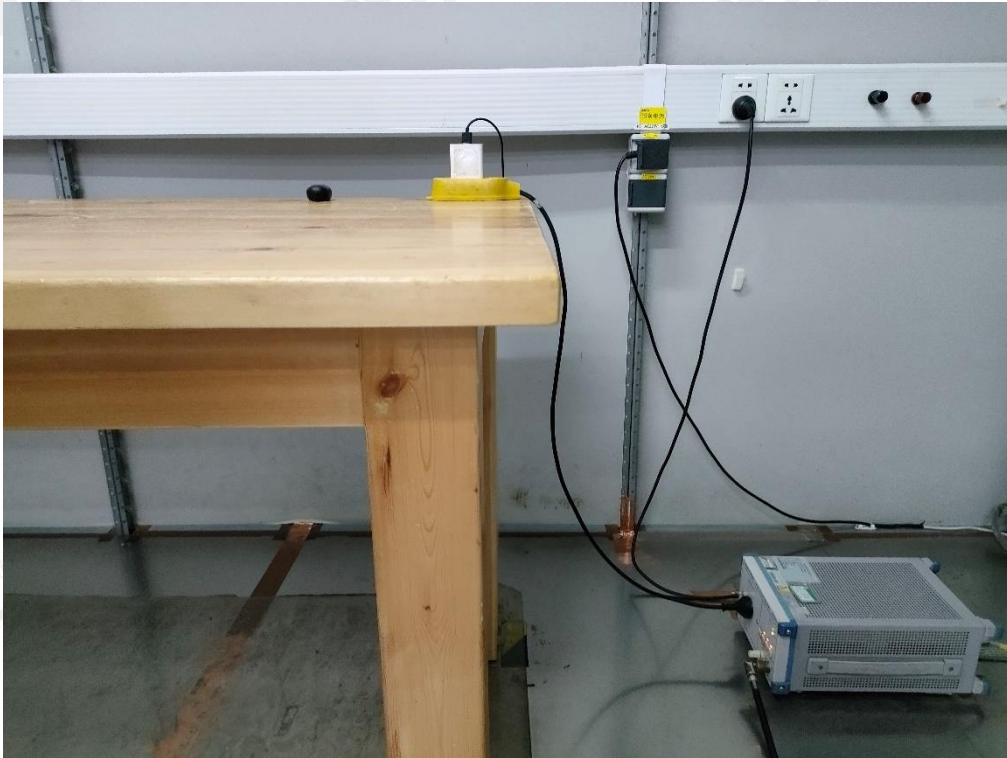

4. Radiated Emissions Test

4.1. Test equipment

Equipment	Manufacturer	Model No.	Serial No.	Last Cal.	Cal. Interval
<input checked="" type="checkbox"/> 1# Radiation chamber					
EMI Test Receiver	R&S	ESU8	100316	Aug. 26, 2022	1 Year
Spectrum analyzer	Agilent	E4440A	MY46185770	Apr. 27, 2023	1 Year
Trilog Broadband Antenna	Schwarzbeck	VULB9163	9163-462	Aug. 22, 2022	1 Year
Active Loop antenna	Schwarzbeck	FMZB-1519	1519-038	Sep. 29, 2022	1 Year
Double Ridged Horn Antenna	R&S	HF907	100276	Aug. 23, 2022	1 Year
Broad Band Horn Antenna	Schwarzbeck	BBHA 9170	790	Apr. 26, 2023	1 Year
Pre-amplifier	COM-POWER	PAM-118A	18040119	Aug. 26, 2022	1 Year
Pre-amplifier	COM-POWER	PAM-840A	461369	Apr. 27, 2023	1 Year
RF Cable	HUBSER	CP-X2+ CP-X1	W11.03+ W12.02	Aug. 26, 2022	1 Year
RF Cable	N/A	5m+6m+1m	06270619	Aug. 26, 2022	1 Year
MI Cable	HUBSER	C10-01-01-1M	1091629	Aug. 26, 2022	1 Year
Test software	Audix	E3	V 6.11111b	N/A	N/A
<input type="checkbox"/> 2# Radiation chamber					
EMI Test Receiver	R&S	ESCI	101032	Apr. 23, 2023	1 Year
Spectrum analyzer	Agilent	E4440A	MY46185770	Apr. 27, 2023	1 Year
Trilog Broadband Antenna	Schwarzbeck	VULB 9163	9163-994	Aug. 10, 2022	1 Year
Trilog Broadband Antenna	Schwarzbeck	VULB 9161	9161-4034	Sep. 29, 2022	1 Year
Active Loop antenna	Schwarzbeck	FMZB-1519	1519-038	Sep. 29, 2022	1 Year
RF Cable	MI Cable	RG214-11	DDT-ZC01497	Apr. 27, 2023	1 Year
Test software	Audix	E3	V 6.11111b	N/A	N/A
<input checked="" type="checkbox"/> 10m chamber					
Pre-amplifier	SONOMA	310N	187133	Jul. 21, 2022	1 Year
Pre-amplifier	SONOMA	310N	310816	Jul. 21, 2022	1 Year
EMI Test Receiver	R&S	ESC17	100783	Apr. 23, 2023	1 Year
EMI Test Receiver	R&S	ESCI	101026	Apr. 23, 2023	1 Year
Trilog Broadband Antenna	Schwarzbeck	VULB9163	01426	Aug. 03, 2022	1 Year
Trilog Broadband Antenna	Schwarzbeck	VULB9163	01427	Jul. 28, 2022	1 Year
Spectrum analyzer	Agilent	E4447A	MY50180031	Apr. 23, 2023	1 Year
RF cable	N/A	H0.5M+1M+3M (6M+4M)	H051364	Sep. 28, 2022	1 Year
RF cable	N/A	V0.5M+1M+3M (11M+6M)	V0513116	Sep. 28, 2022	1 Year
Pre-amplifier	COM-POWER	PAM-118A	18040119	Aug. 26, 2022	1 Year
Notes. N/A means Not applicable.					

4.2. Block diagram of test setup

Below 1 GHz

For table-top equipment

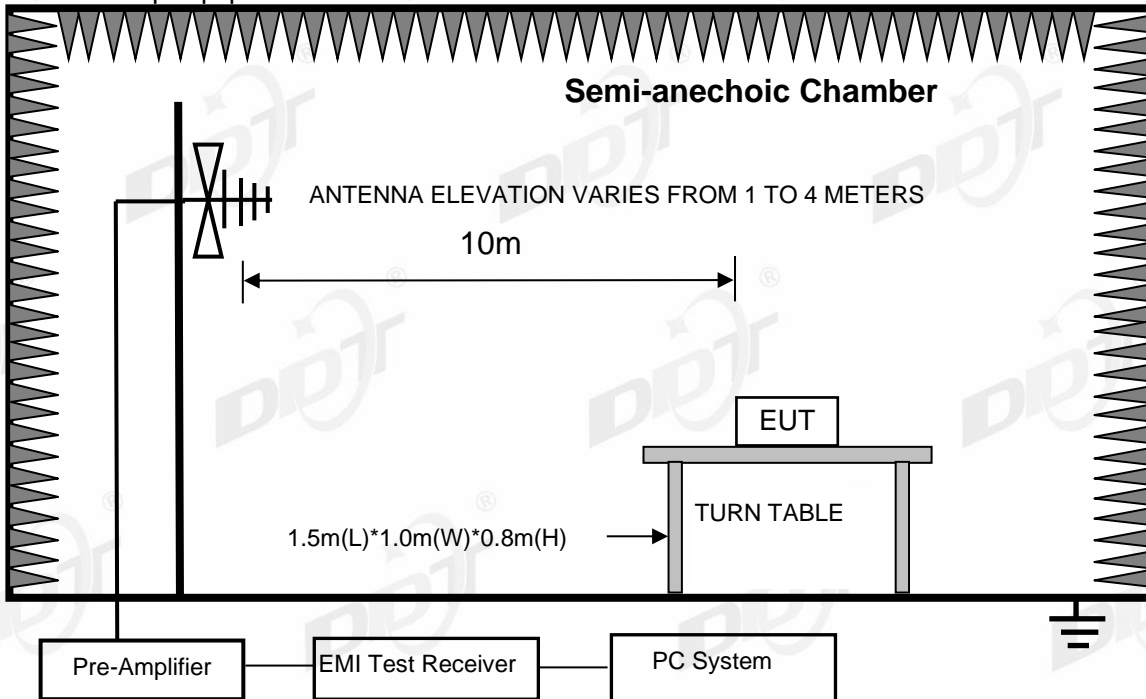

For floor standing equipment

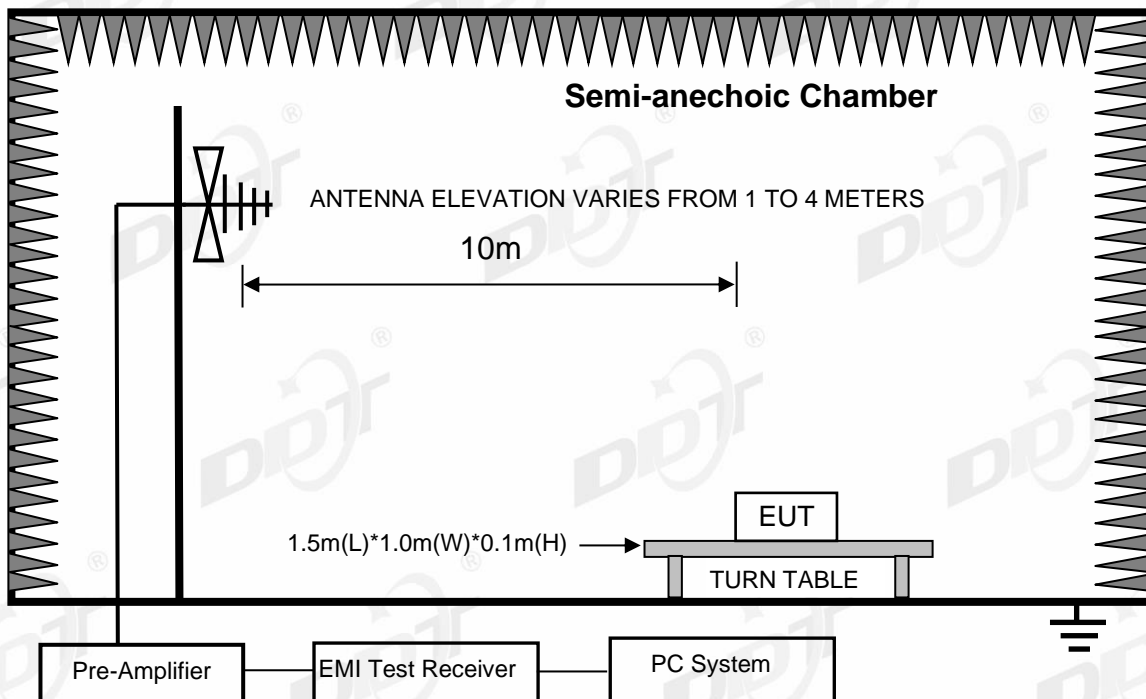

For combinations equipment

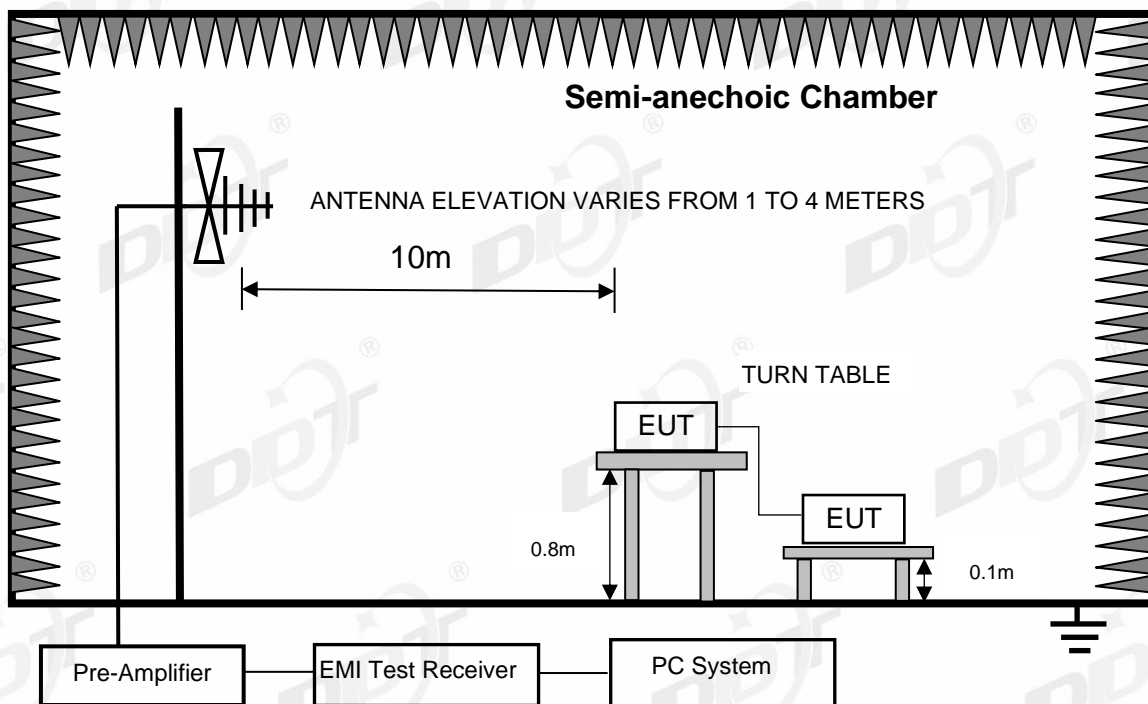

Above 1 GHz
For table-top equipment

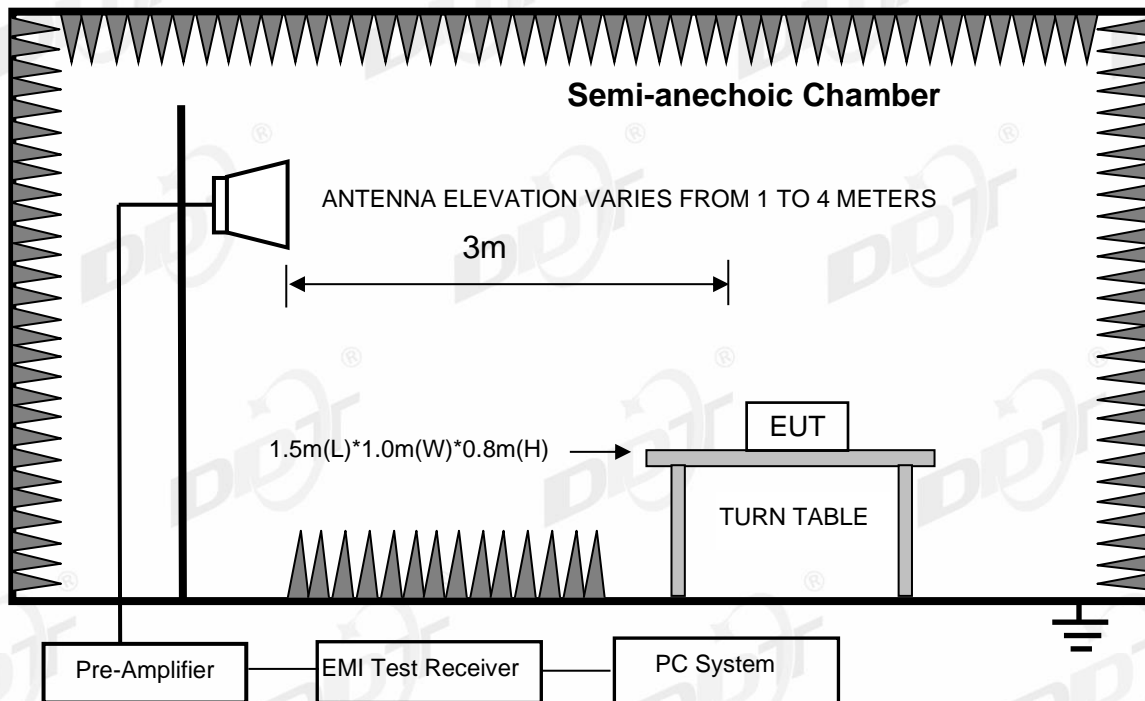

For floor standing equipment

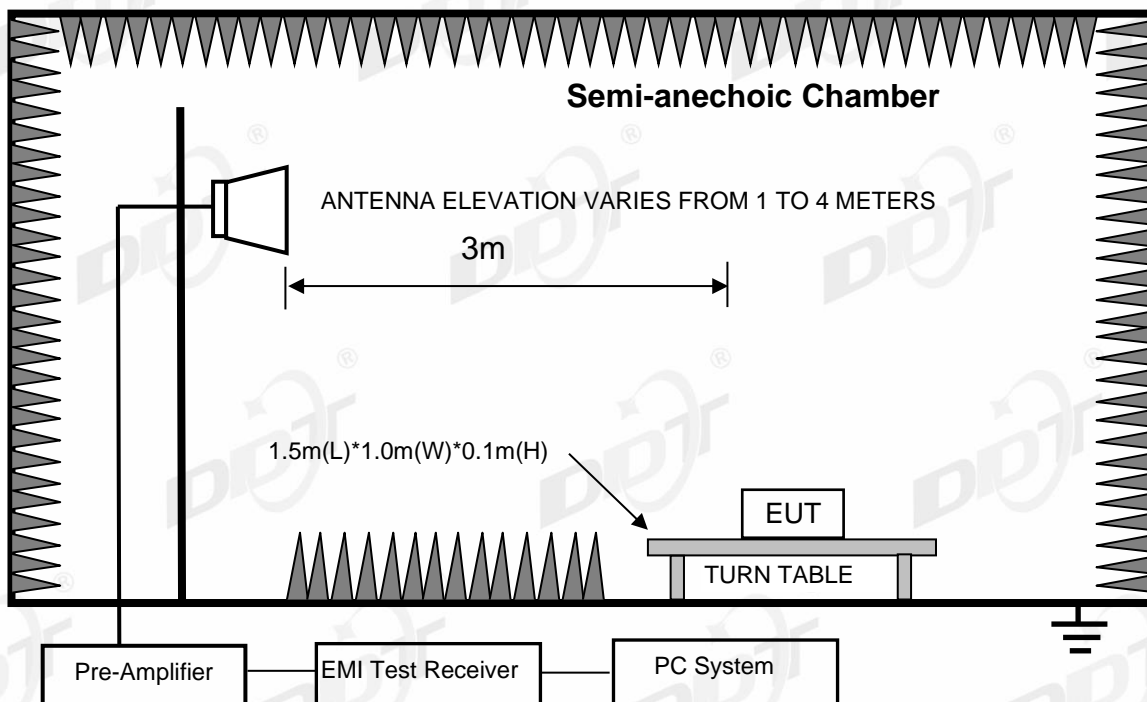

For combinations equipment

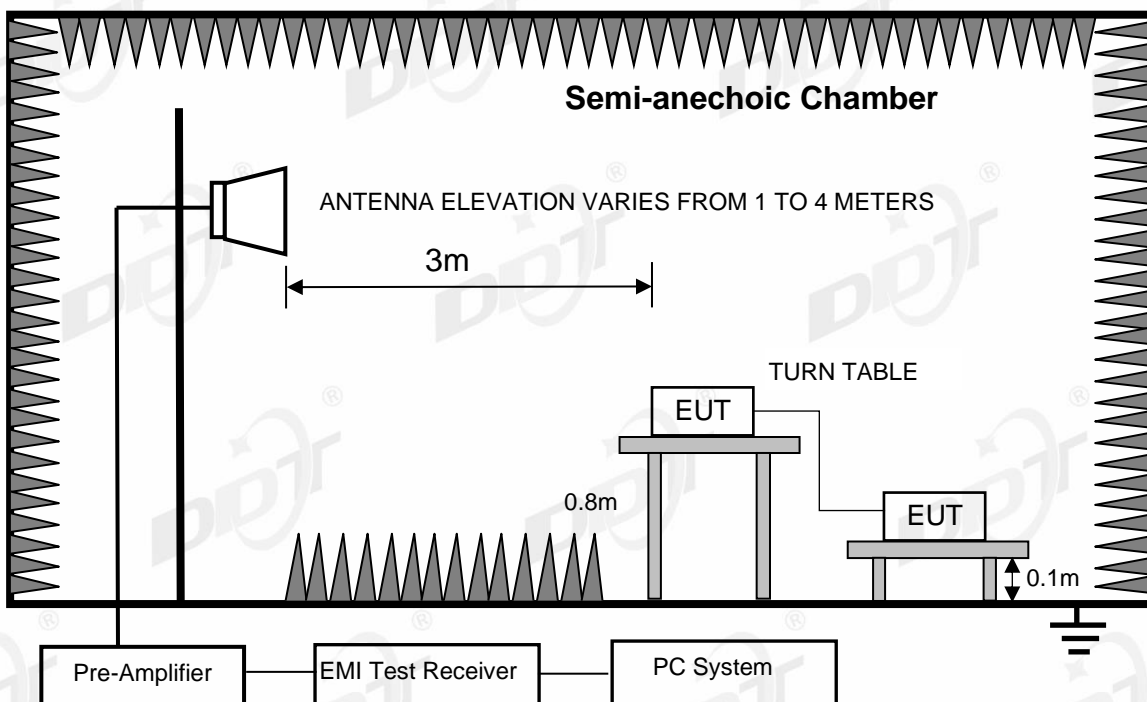

4.3. Limits

Class A

Equipment	Frequency	Field Strengths Limits at 10m measuring distance dB(μ V)/m	Field Strengths Limits at 3m measuring distance dB(μ V)/m
Class A Equipment	30 MHz to 230 MHz	40	50
	230 MHz to 1 GHz	47	57
	1 GHz to 3 GHz	/	Average:56; Peak:76
	3 GHz to 6 GHz	/	Average:60; Peak:80

Class B

Equipment	Frequency	Field Strengths Limits at 10m measuring distance dB(μ V)/m	Field Strengths Limits at 3m measuring distance dB(μ V)/m
Class B Equipment	30 MHz to 230 MHz	30	40
	230 MHz to 1 GHz	37	47
	1 GHz to 3 GHz	/	Average:50; Peak:70
	3 GHz to 6 GHz	/	Average:54; Peak:74
FM receivers*	30 MHz to 1 GHz	Fundamental 50	Fundamental 60
	30 MHz to 300 MHz	Harmonics 42	Harmonics 52
	300 MHz to 1 GHz	Harmonics 46	Harmonics 56

*: these relaxed limits apply only to emission at the fundamental and harmonic frequencies of the local oscillator signals at all other frequencies shall be compliant with the limits of class B equipment given above.

Note: (1) The smaller limit shall apply at the cross point between two frequency bands.

(2) Distance is the distance in meters between the measuring instrument, antenna and the closest point of any part of the device or system.

4.4. Assistant equipment used for test

Assistant equipment	Manufacturer	Model number	Description	other
Adapter	HUAWEI	HW-100400C01 JB91L6L7S04031	Input: 100-240V~ 50/60Hz, Output: 5V/2A or 9V/2A or 10V/4A MAX	N/A
USB cable	N/A	N/A	Length: 1.00m, Unshielded	N/A

4.5. Test procedure

- (1) The EUT was placed on a non-metallic table, 0.8m (table-top device)/0.1m (floor-stand device) above the ground plane inside a semi-anechoic chamber.
- (2) Test antenna center was located 3m or 10m from the EUT and assistant equipment boundary (imaginary circular periphery) on an adjustable mast. A pre-scan was first performed in order to find prominent radiated emissions. For final emissions measurements at each frequency of interest, the EUT were rotated and the antenna

height was varied between 1m and 4m in order to maximize the emission.

Measurements in both horizontal and vertical polarities were made and the data was recorded. In order to find the maximum emission, the relative positions of equipment and all of the interface cables were changed according to EN 55032 on radiated emission test.

(3) Spectrum frequency from 30 MHz to 1 GHz/6 GHz was investigated.

(4) For final emissions measurements at each frequency of interest, the EUT were rotated and the antenna height was varied between 1m and 4m in order to maximize the emission. Measurements in both horizontal and vertical polarities were made and the data was recorded. In order to find the maximum emission, the relative positions of equipment and all of the interface cables were changed according to EN 55032 on Radiated Emission test.

(5) For emissions from 30 MHz to 1 GHz, Quasi-Peak values were measured with EMI Receiver and the bandwidth of Receiver is 120 kHz.

(6) For emissions above 1 GHz, both Peak and Average level were measured with Spectrum Analyzer, and the RBW is set at 1 MHz VBW is set at 3 MHz.

4.6. Test result

PASS. (See below detailed test result)

Note 1: All emissions not reported below are too low against the prescribed limits;

Note 2: "-----" means Peak detection.

Below 1 GHz

TR-4-E-009 Radiated Emission Test Result

Test Date: 2023-05-16 **Tested By:** Croydon Deng
EUT: TWS Earphone **Model Number:** JBuds Mini
Test Mode: Charging mode **Power Supply:** AC 230V/50Hz
Condition: Temp:20.9°C;Humi:50.1% **Test Site:** DDT 10M Chamber
File Path: d:\ts\2023 report data\Q23051012-1E\0516 10M RE\1
Memo:

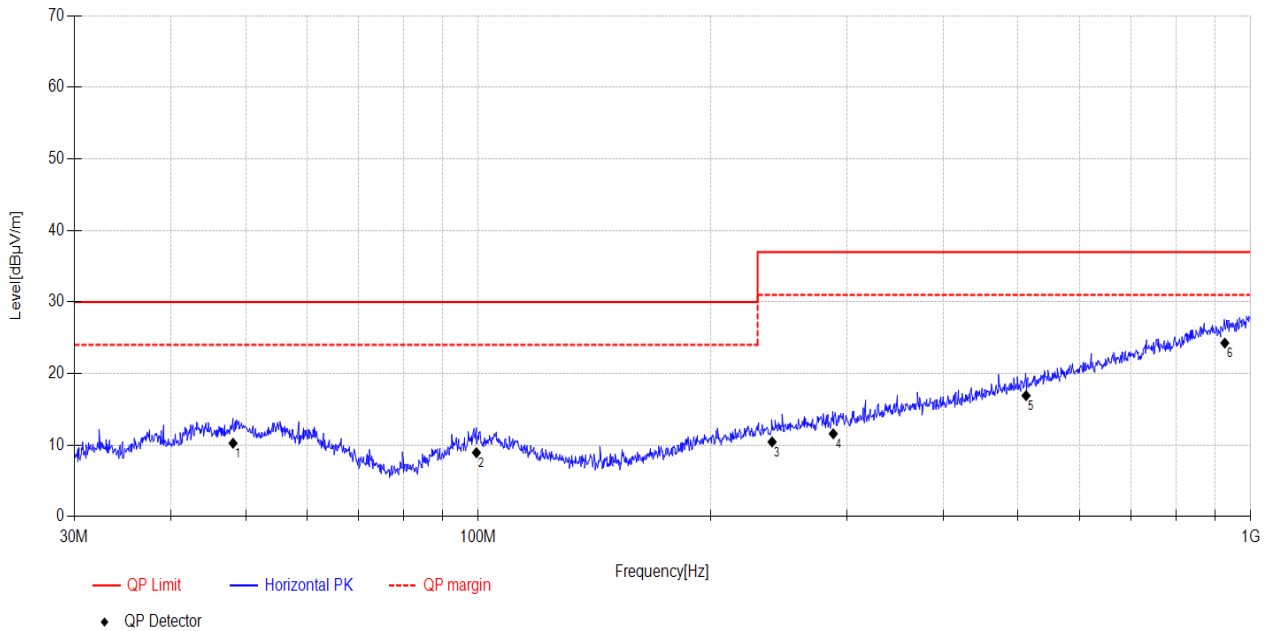

Final Data List								
NO.	Freq. [MHz]	Reading [dBµV]	Factor [dB]	Result [dBµV/m]	Limit [dBµV/m]	Margin [dB]	Detector	Polarity
1	48.15	24.75	-14.49	10.26	30.00	19.74	QP	Horizontal
2	99.47	25.06	-16.11	8.95	30.00	21.05	QP	Horizontal
3	240.16	24.88	-14.43	10.45	37.00	26.55	QP	Horizontal
4	288.17	24.96	-13.37	11.59	37.00	25.41	QP	Horizontal
5	512.01	25.33	-8.41	16.92	37.00	20.08	QP	Horizontal
6	925.79	24.98	-0.71	24.27	37.00	12.73	QP	Horizontal

- Note: 1. Result Level = Reading + Factor.
 2. If Peak Result complies with QP limit, QP Result is deemed to comply with QP limit.
 3. Test setup: RBW: 120 kHz, VBW: 300 kHz, Sweep time: auto.

TR-4-E-009 Radiated Emission Test Result

Test Date: 2023-05-16 **Tested By:** Croydon Deng
EUT: TWS Earphone **Model Number:** JBuds Mini
Test Mode: Charging mode **Power Supply:** AC 230V/50Hz
Condition: Temp:20.9°C;Humi:50.1% **Test Site:** DDT 10M Chamber
File Path: d:\ts\2023 report data\Q23051012-1E\0516 10M RE\2

Memo:

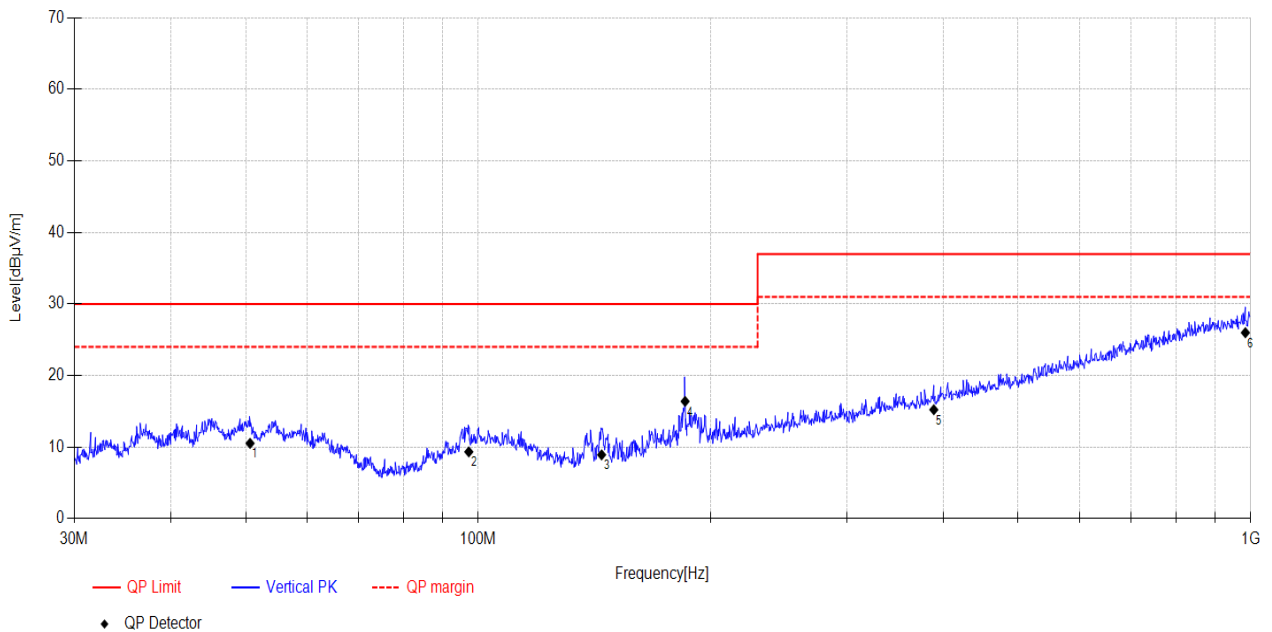

Final Data List								
NO.	Freq. [MHz]	Reading [dBµV]	Factor [dB]	Result [dBµV/m]	Limit [dBµV/m]	Margin [dB]	Detector	Polarity
1	50.66	24.92	-14.39	10.53	30.00	19.47	QP	Vertical
2	97.23	25.43	-16.09	9.34	30.00	20.66	QP	Vertical
3	144.47	27.85	-18.93	8.92	30.00	21.08	QP	Vertical
4	185.29	32.9	-16.50	16.40	30.00	13.60	QP	Vertical
5	388.86	25.27	-10.04	15.23	37.00	21.77	QP	Vertical
6	984.35	24.23	1.77	26.00	37.00	11.00	QP	Vertical

- Note: 1. Result Level = Reading + Factor.
 2. If Peak Result complies with QP limit, QP Result is deemed to comply with QP limit.
 3. Test setup: RBW: 120 kHz, VBW: 300 kHz, Sweep time: auto.

Above 1 GHz

TR-4-E-009 Radiated Emission Test Result

Test Site : DDT 3m Chamber 1# **D:\2023 RE 1# Report data\Q23051012-1E\0517 RE-H.EM6**
Test Date : 2023-05-17 **Tested By** : Youbin
EUT : TWS Earphone **Model Number** : JBuds Mini
Power Supply : AC 230V/50Hz **Test Mode** : Charging mode
Condition : TEMP:23.0°C, RH:57.1%, BP:101.4kPa **Antenna/Distance** : 2022 HF907/3m/VERTICAL
Memo :

Data: 9

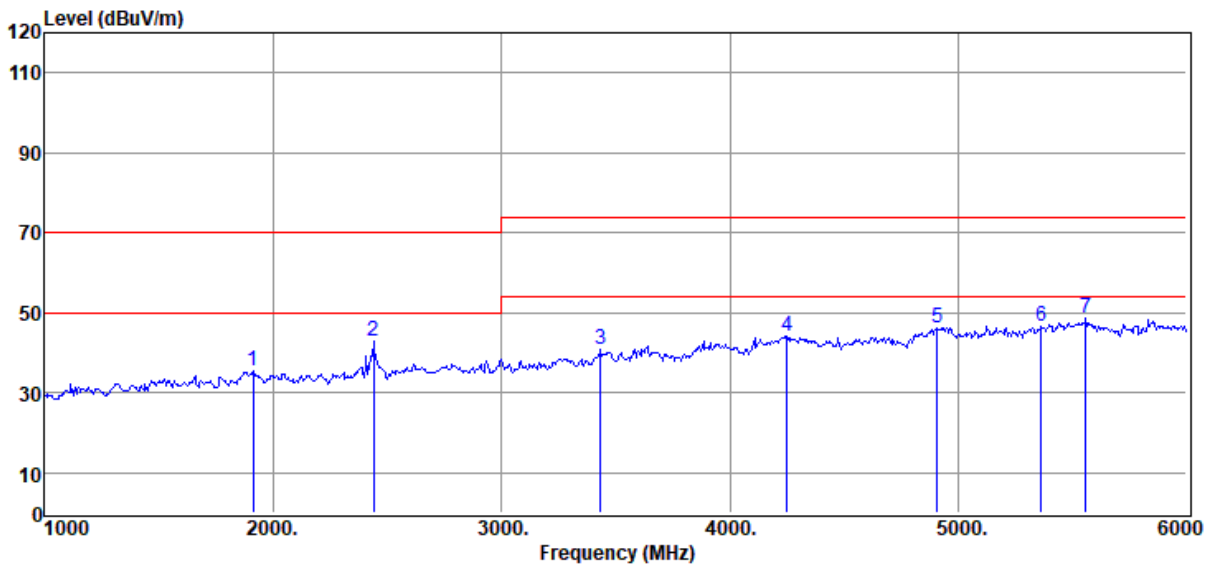

Item (Mark)	Freq. (MHz)	Read Level (dBμV)	Antenna Factor (dB/m)	PRM Factor (dB)	Cable Loss (dB)	Result Level (dBμV/m)	Limit Line (dBμV/m)	Over Limit (dB)	Detector	Polarization
1	1915.00	43.63	29.32	41.51	3.97	35.41	70.00	-34.59	Peak	VERTICAL
2	2440.00	49.93	30.82	42.30	4.56	43.01	70.00	-26.99	Peak	VERTICAL
3	3435.00	45.21	32.99	43.29	5.72	40.63	74.00	-33.37	Peak	VERTICAL
4	4250.00	44.41	36.00	43.30	7.03	44.14	74.00	-29.86	Peak	VERTICAL
5	4910.00	44.57	36.32	43.04	8.52	46.37	74.00	-27.63	Peak	VERTICAL
6	5365.00	43.64	36.23	42.82	9.63	46.68	74.00	-27.32	Peak	VERTICAL
7	5560.00	44.60	36.48	42.72	10.10	48.46	74.00	-25.54	Peak	VERTICAL

- Note: 1. Result Level = Read Level + Antenna Factor + Cable loss - PRM Factor.
 2. If Peak Result complies with AV limit, AV Result is deemed to comply with AV limit.
 3. Test setup: RBW: 1 MHz, VBW: 3 MHz, Sweep time: auto.
 4. According to standard requirements, the radio carrier and harmonic frequencies of the samples are not included in the test results.

TR-4-E-009 Radiated Emission Test Result

Test Site : DDT 3m Chamber 1# **D:\2023 RE 1# Report data\Q23051012-1E\0517 RE-H.EM6**
Test Date : 2023-05-17 **Tested By** : Youbin
EUT : TWS Earphone **Model Number** : JBuds Mini
Power Supply : AC 230V/50Hz **Test Mode** : Charging mode
Condition : TEMP:23.0°C, RH:57.1%, BP:101.4kPa **Antenna/Distance** : 2022 HF907/3m/HORIZONTAL

Memo :

Data: 10

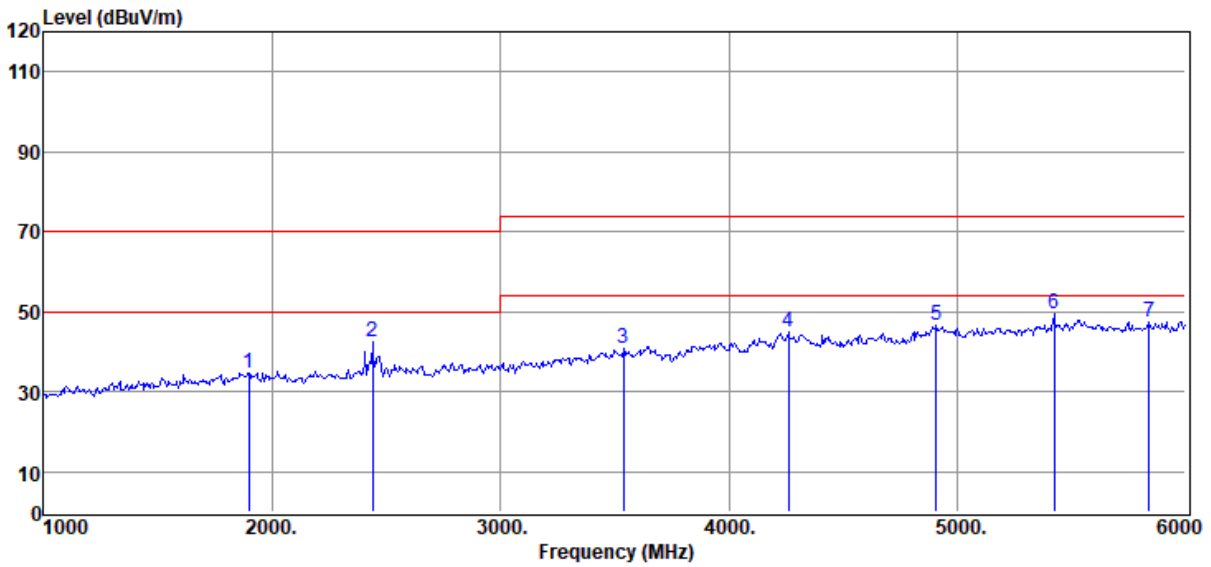

Item (Mark)	Freq. (MHz)	Read Level (dBμV)	Antenna Factor (dB/m)	PRM Factor (dB)	Cable Loss (dB)	Result Level (dBμV/m)	Limit Line (dBμV/m)	Over Limit (dB)	Detector	Polarization
1	1900.00	43.14	29.20	41.50	3.96	34.80	70.00	-35.20	Peak	HORIZONTAL
2	2440.00	49.47	30.82	42.30	4.56	42.55	70.00	-27.45	Peak	HORIZONTAL
3	3540.00	44.62	33.68	43.31	5.86	40.85	74.00	-33.15	Peak	HORIZONTAL
4	4260.00	45.02	36.00	43.30	7.06	44.78	74.00	-29.22	Peak	HORIZONTAL
5	4910.00	44.61	36.32	43.04	8.52	46.41	74.00	-27.59	Peak	HORIZONTAL
6	5425.00	46.23	36.10	42.79	9.77	49.31	74.00	-24.69	Peak	HORIZONTAL
7	5840.00	43.24	36.12	42.58	10.74	47.52	74.00	-26.48	Peak	HORIZONTAL

- Note: 1. Result Level = Read Level + Antenna Factor + Cable loss - PRM Factor.
 2. If Peak Result complies with AV limit, AV Result is deemed to comply with AV limit.
 3. Test setup: RBW: 1 MHz, VBW: 3 MHz, Sweep time: auto.
 4. According to standard requirements, the radio carrier and harmonic frequencies of the samples are not included in the test results.

4.7. Test photo

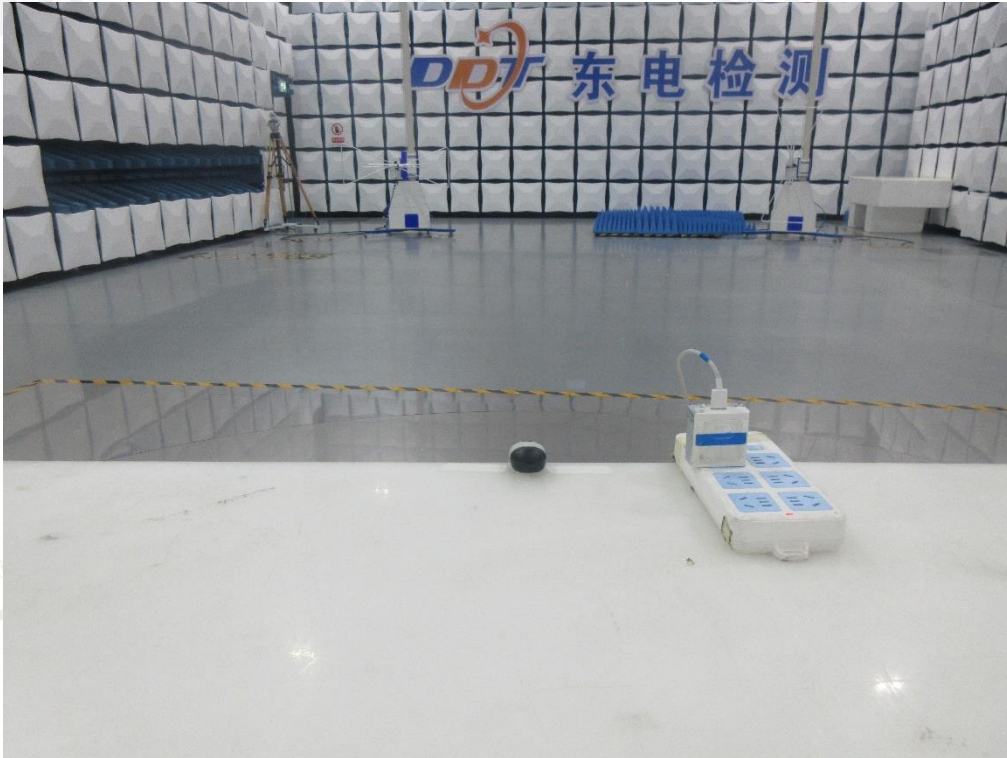

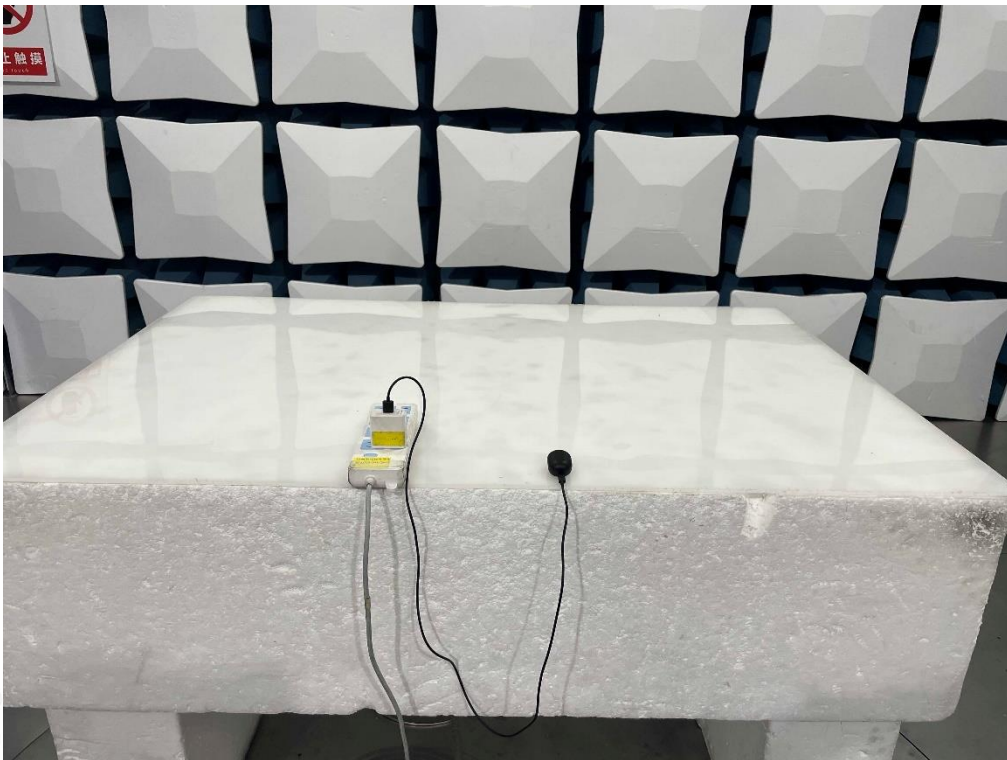
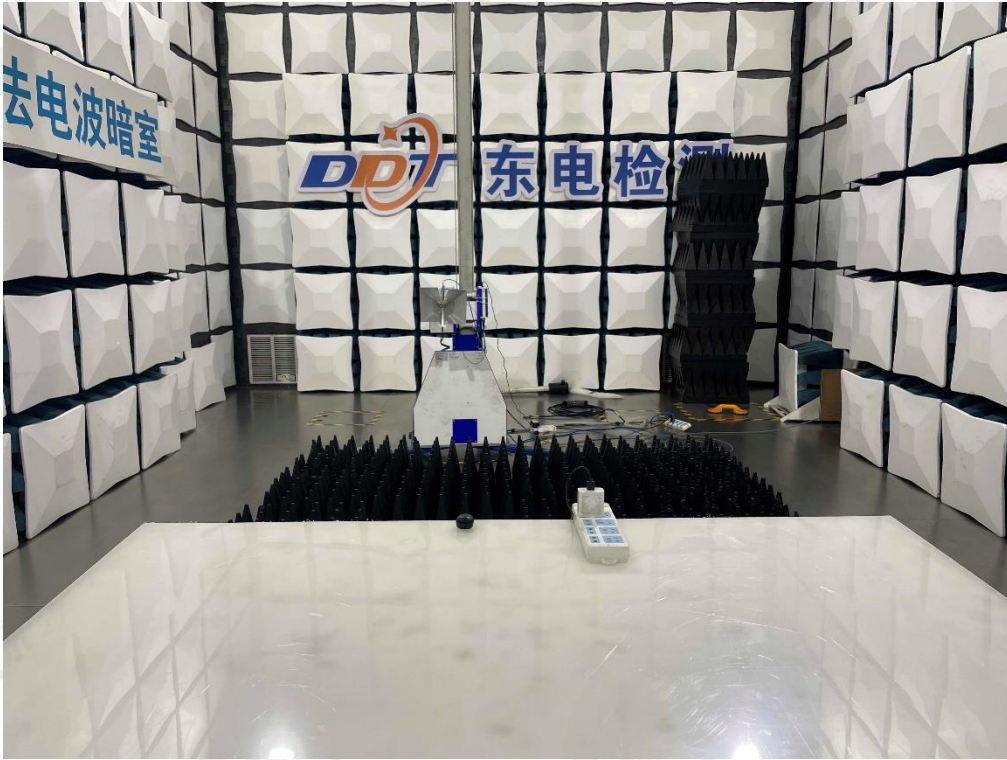

5. Harmonic Current and Voltage Fluctuations & Flicker Test

5.1. Test equipment

Equipment	Manufacturer	Model No.	Serial No.	Last Cal.	Cal. Interval
Harmonic tester	AMETEK	500lixCTS-400-413/pacs-1	HAP1000-1P230V-0205	Jul. 15, 2022	1Year

Note: This test was subcontracted to Bureau of Quality and Technology Supervision of Dongguan City.

5.2. Block diagram of test setup

Table-top device

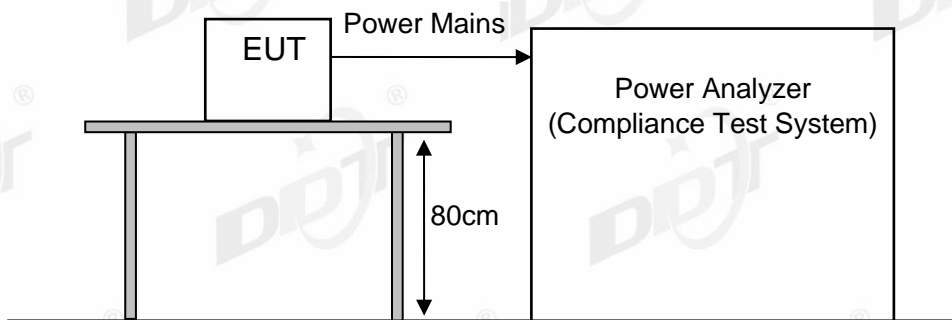

Floor-standing device

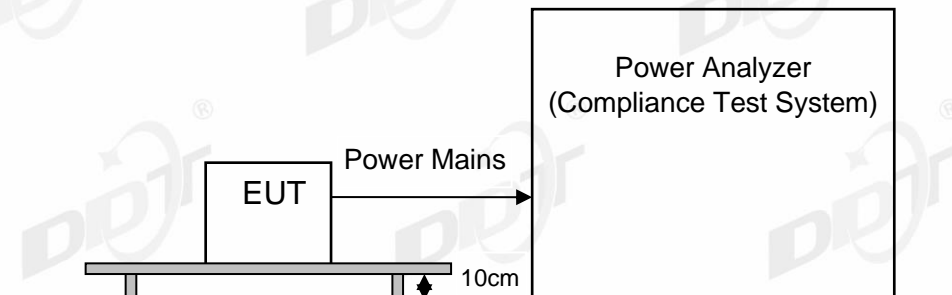

5.3. Harmonic current limits

Classification of equipment:

Class A: balanced three-phase equipment; household appliances, excluding equipment identified as Class D; tools, excluding portable tools; dimmers for incandescent lamps; audio equipment. (Equipment not specified in one of the three other classes shall be considered as Class A equipment.)

Class D: equipment having a specified power less than or equal to 600 W, of the following types: personal computers and personal computer monitors; television receivers.

For Class A equipment

Harmonic order(n)	Maximum permissible harmonic current (A)
Odd harmonics	
3	2.30
5	1.14
7	0.77
9	0.40
11	0.33
13	0.21
15≤n≤39	0.15*15/n
Even harmonics	
2	1.08
4	0.43
6	0.30
8≤n≤40	0.23*8/n

Note: λ is the circuit power factor.

For Class D equipment

Harmonic order(n)	Maximum permissible harmonic current per watt (mA/W)	Maximum permissible harmonic current (A)
3	3.4	2.30
5	1.9	1.14
7	1.0	0.77
9	0.5	0.40
11	0.35	0.33
13≤n≤39 (odd harmonic only)	3.85/n	0.21*13/n

5.4. Voltage fluctuations & flicker Limit

Test Item	Limit	Note
Pst	1.0	Pst means Short-term flicker indicator
Plt	0.65	Plt means long-term flicker indicator
Tdt	0.5	Tdt means maximum time that dt exceeds 3.3%
dmax(%)	4%	dmax means maximum relative voltage change.
dc(%)	3.3%	dc means relative steady-state voltage change.

5.5. Assistant equipment used for test

Assistant equipment	Manufacturer	Model number	Description	other
Adapter	SAMSUNG	EP-TA200	Input: 100-240~, 50/60Hz, 0.5A; Output: 9V/1.67A or 5V/2A	N/A
USB cable	N/A	N/A	Length: 1.00m, Unshielded	N/A

5.6. Test procedure

For Harmonic current test:

The EUT was placed on the top of a wooden table 0.8 meters above the ground and operated to produce the maximum harmonic components under normal operating conditions for each successive harmonic component in turn. The correspondent test program of test instrument to measure the current harmonics emanated from EUT is chosen. The measure time shall be not less than the necessary for the EUT to be exercised.

For Voltage fluctuations & flicker

The EUT was placed on the top of a wooden table 0.8 meters above the ground and operated to produce the most unfavorable sequence of voltage changes under normal conditions during the flick measurement; the measure time shall include that part of whole operation changes. The observation period for short-term flicker indicator is 10 minutes and the observation period for long-term flicker indicator is 2 hours.

5.7. Test result

Harmonic current test result:

N/A: Not applicable

Note: According to IEC 61000-3-2 Clause 7, this product belongs to exceptions of Clause 7 or Annex C. limits are not specified in this standard.

Voltage fluctuations & flicker test result:

Flicker Test Summary per IEC61000-3-3:2013/AMD1:2017 (Run time)

EUT: TWS Earphone

Tested by: Haier Wu

Test category: All parameters (European limits)

Test Margin: 100

Test date: 2023/5/22

Start time: 11:49:25

End time: 11:59:52

Test duration (min): 10

Data file name: F-000321.cts_data

Comment: Comment

Customer: Customer information

Test Result: Pass

Status: Test Completed

Pst_i and limit line

European Limits

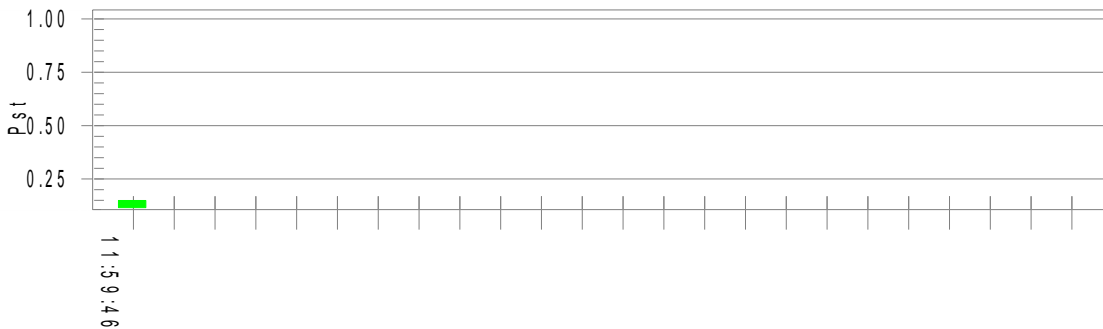

Plt and limit line



Parameter values recorded during the test:

Vrms at the end of test (Volt):	220.56			
Highest dt (%):		Test limit (%):		
T-max (mS):	0	Test limit (mS):	500.0	Pass
Highest dc (%):	0.00	Test limit (%):	3.30	Pass
Highest dmax (%):	0.00	Test limit (%):	4.00	Pass
Highest Pst (10 min, period):	0.149	Test limit:	1.000	Pass
Highest Plt (2 hr. period):	0.065	Test limit:	0.650	Pass

5.8. Test photo

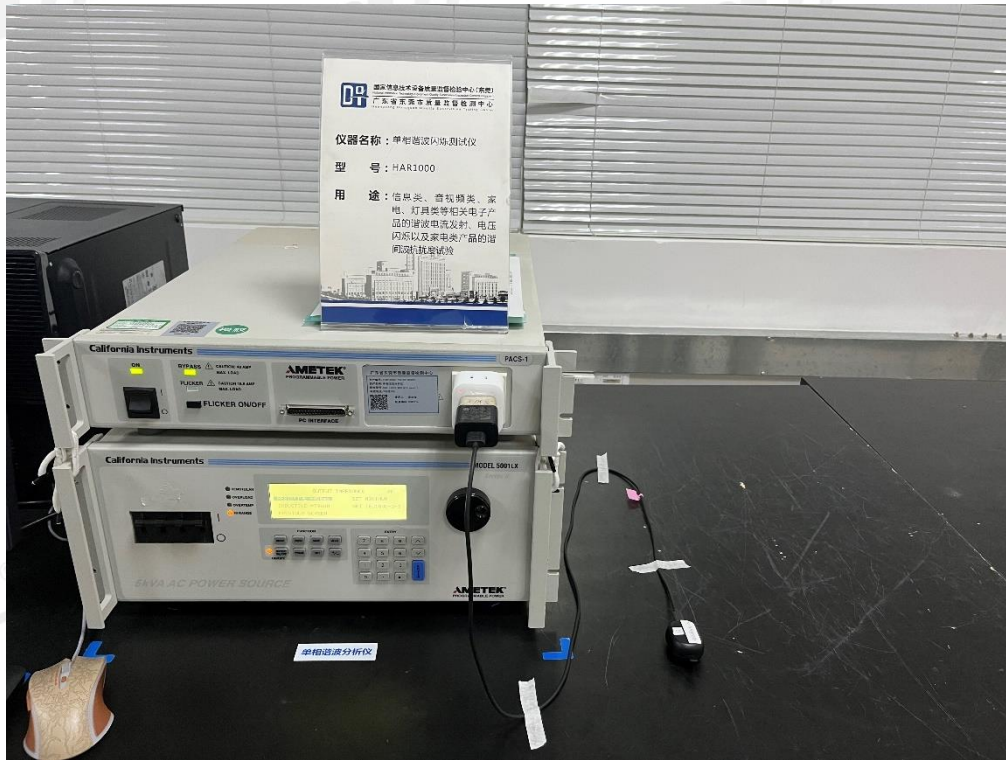

6. Electrostatic Discharge Test

6.1. Test equipment

Equipment	Manufacturer	Model No.	Serial No.	Last Cal.	Cal. Interval
<input checked="" type="checkbox"/> ESD Generator	TESEQ	NSG 437	1635	Apr. 22, 2023	1Year
<input type="checkbox"/> ESD Generator	TESEQ	NSG 437	981	Sep. 01, 2022	1Year

6.2. Block diagram of test setup

Table-top equipment

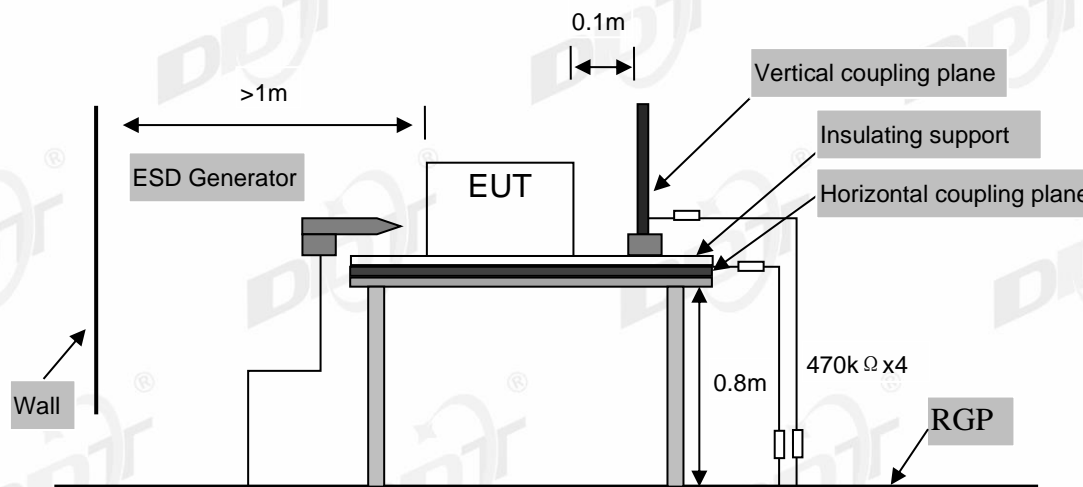

Floor-standing equipment

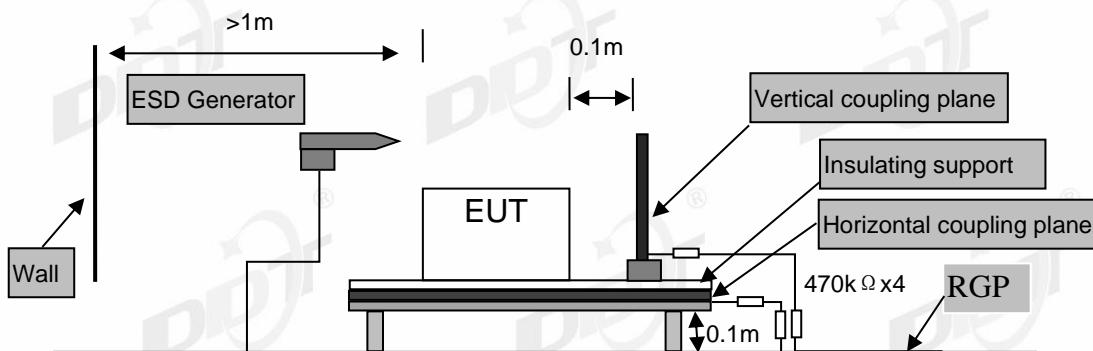

6.3. Test levels and performance criterion

Test Level		Performance Criteria
Air Discharge	$\pm 2\text{kV}$, $\pm 4\text{kV}$ and $\pm 8\text{kV}$	B
Contact Discharge	$\pm 4\text{kV}$	

Performance criteria B description: During the test, degradation of performance is allowed. However, no change of operating state or stored data is allowed to persist after the test. After the test, the EUT shall continue to operate as intended without operator intervention. No degradation

of performance or loss of function is allowed, after the application of the phenomena below a performance level specified by the manufacturer, when the EUT is used as intended.

6.4. Assistant equipment used for test

Assistant equipment	Manufacturer	Model number	Description	other
Adapter	SAMSUNG	EP-TA200	Input: 100-240~, 50/60Hz, 0.5A; Output: 9V/1.67A or 5V/2A	N/A
USB cable	N/A	N/A	Length: 1.00m, Unshielded	N/A

6.5. Test procedure

Air Discharge:

The test was applied on non-conductive surfaces of EUT. The round discharge tip of the discharge electrode was approached as fast as possible to touch the EUT. After each discharge, the discharge electrode was removed from the EUT. The generator was re-triggered for a new single discharge and repeated 20 times for each pre-selected test point. This procedure was repeated until all the air discharge completed.

Contact Discharge:

All the procedure was same as air discharge. Except that the generator was re-triggered for a new single discharge. The tip of the discharge electrode was touching the EUT before the discharge switch was operated.

Indirect discharge for horizontal coupling plane:

At least 20 single discharges were applied to the horizontal coupling plane, at points on each side of the EUT. The discharge electrode positions vertically at a distance of 0.1m from the EUT and with the discharge electrode touching the coupling plane.

Indirect discharge for vertical coupling plane:

At least 20 single discharges were applied to the center of one vertical edge of the coupling plane. The coupling plane, of dimensions 0.5m X 0.5m, was placed parallel to, and positioned at a distance of 0.1m from the EUT. Discharges were applied to the coupling plane, with this plane in sufficient different positions that the four faces of the EUT are completely illuminated.

6.6. Test result

Test Site: DDT <input checked="" type="checkbox"/> 1# or <input type="checkbox"/> 2# Electrostatic Discharge Room
Ambient Condition: <u>22.1</u> °C, <u>52.1</u> %RH, <u>101.4</u> kPa
According Standard: <input checked="" type="checkbox"/> EN 61000-4-2, <input checked="" type="checkbox"/> EN 55035, <input type="checkbox"/> other:

Operation Mode:	Charging mode	Test Power Supply:	AC 230V/50Hz		
Test Times: 20 times at each point for contact discharge; 20 times at each point for air discharge. <input checked="" type="checkbox"/> 1 <input type="checkbox"/> 5 <input type="checkbox"/> 10 seconds interval for each discharge.					
Type of discharge	Test Level	Test Point	Required	Observation	Result
Contact to EUT	±4kV	/	B	/	/
Contact to Coupling Planes	±4kV	Coupling Planes	B	A	Pass
Air	±2 kV /±4 kV /±8kV	3, 5, 6, 8, 9	B	B	Pass

Operation Mode:	Case charging mode	Test Power Supply:	AC 230V/50Hz		
Test Times: 20 times at each point for contact discharge; 20 times at each point for air discharge. <input checked="" type="checkbox"/> 1 <input type="checkbox"/> 5 <input type="checkbox"/> 10 seconds interval for each discharge.					
Type of discharge	Test Level	Test Point	Required	Observation	Result
Contact to EUT	±4kV	7	B	A	Pass
Contact to Coupling Planes	±4kV	Coupling Planes	B	A	Pass
Air	±2 kV /±4 kV /±8kV	6, 8, 9	B	A	Pass

Operation Mode:	Earbud charging mode	Test Power Supply:	Battery		
Test Times: 20 times at each point for contact discharge; 20 times at each point for air discharge. <input checked="" type="checkbox"/> 1 <input type="checkbox"/> 5 <input type="checkbox"/> 10 seconds interval for each discharge.					
Type of discharge	Test Level	Test Point	Required	Observation	Result
Contact to EUT	±4kV	/	B	/	/
Contact to Coupling Planes	±4kV	Coupling Planes	B	A	Pass
Air	±2 kV /±4 kV /±8kV	3, 5, 6, 8, 9	B	A	Pass

Test Point:					
No.	Description	No.	Description	No.	Description
1	Charging point	4	Trumpet	7	Charging column
2	Hole	5	Gap 1	8	LED 2
3	LED 1	6	Type-C port	9	Gap 2

Observation Description:
A: Normal performance within limits specified by the manufacturer requestor or purchaser.
B:

Test Engineer:	Elosky Liu	Review By:	Harmony Zeng
Test Date:	Jun. 09, 2023	Review Date:	Jun. 09, 2023

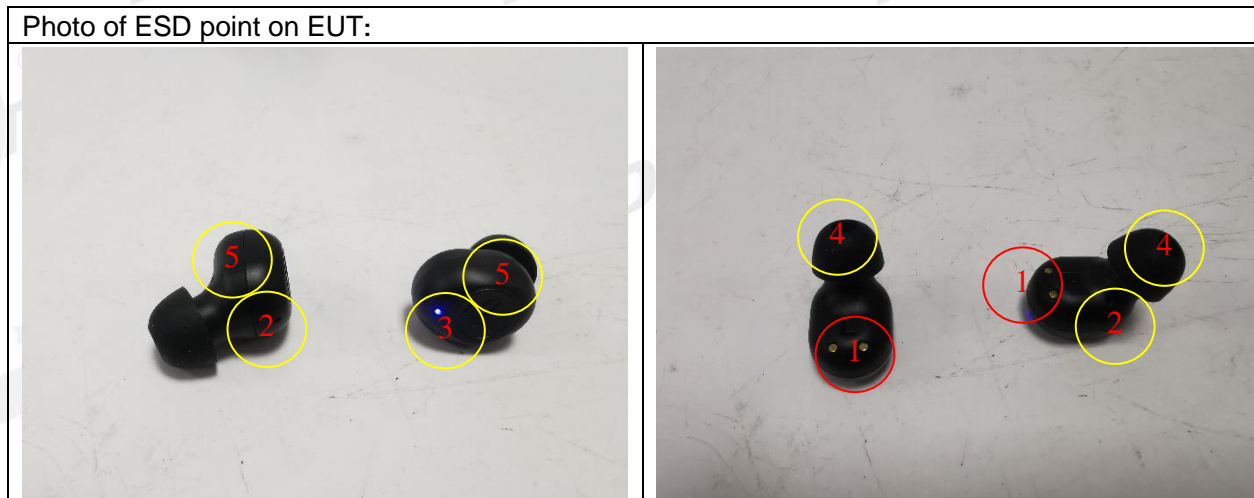

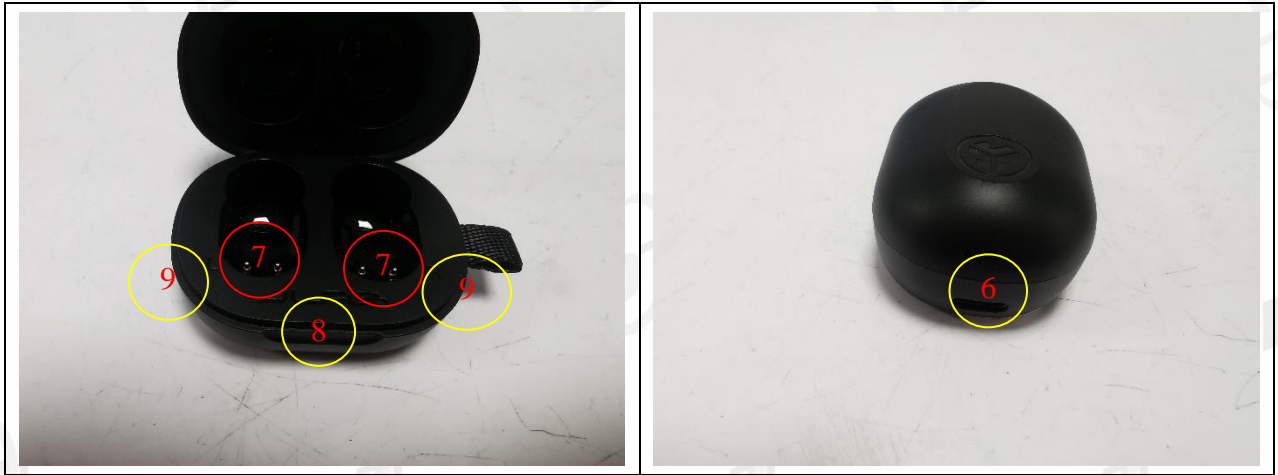

6.7. Test photo



7. Continuous Radio Frequency Disturbances Test

7.1. Test equipment

Equipment	Manufacturer	Model No.	Serial No.	Last Cal.	Cal. Interval
Log-periodic antenna	Schwarzbeck	STLP 9128 D	121	Aug. 27, 2022	1 Year
Log-periodic antenna	Schwarzbeck	STLP 9149	00597	Aug. 27, 2022	1 Year
Field strength probe	PMM	EP-601	611WX80209	Sep. 28, 2022	1 Year
MXU Vector Generator	Agilent	N5182A	MY47420276	Aug. 26, 2022	1 Year
Powermeter	Agilent	E4417A	MY45100364	Sep. 28, 2022	1 Year
Powersensor	Agilent	E9323	MY44420907	Sep. 28, 2022	1 Year
Powersensor	Agilent	E9323	US40410405	Sep. 28, 2022	1 Year
Amplifier	Wonder	HPA80M1000M500	001	Jul. 06, 2022	1 Year
Amplifier	Wonder	HPA1000M2500M300	002	Jul. 06, 2022	1 Year
Amplifier	Wonder	HPA2500M6000M200	003	Jul. 06, 2022	1 Year
Electric Field Sensors	DARE Instruments	CTR1001S	CTR1N-1901008	Oct. 21, 2022	1 Year
Audio Analyzer	R&S	UPV	101570	Aug. 31, 2022	1 Year

7.2. Block diagram of test setup

Table-top equipment

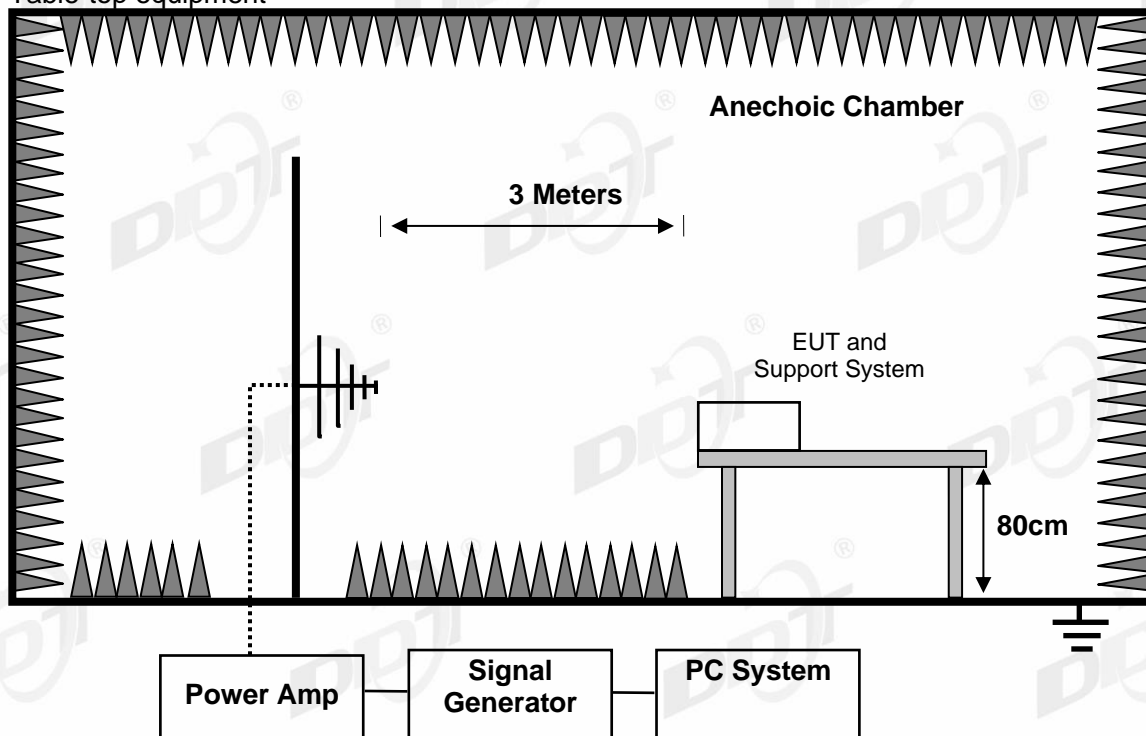

Floor-standing equipment

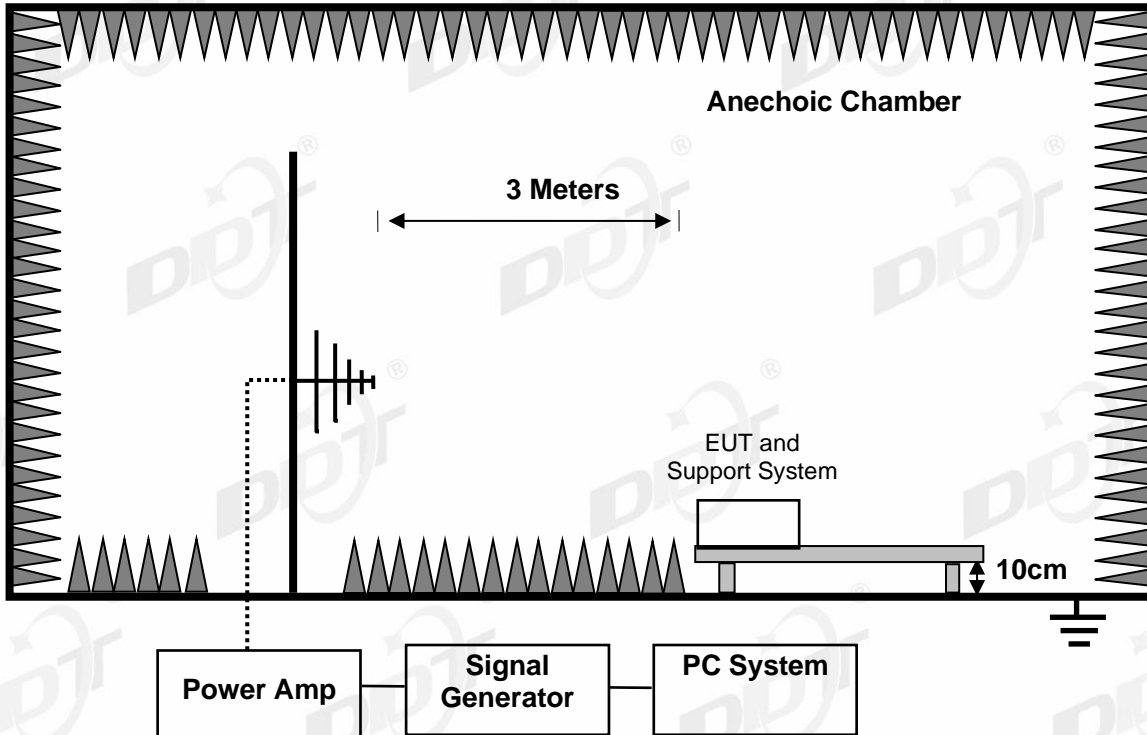

7.3. Test levels and performance criterion

Swept frequency test		Performance Criteria
Frequency (MHz)	80 to 1000	A
Field Strength	3V/m rms voltage level of the unmodulated signal	
Modulation	AM modulated to a depth of 80% by a sine wave of <input checked="" type="checkbox"/> 1 kHz, <input type="checkbox"/> 400 Hz (note 1)	
Step Size	1% increments	
Dwell time	≤5 Sec.	

Spot frequency test		Performance Criteria
Frequency (MHz)	1800, 2600, 3500, 5000	A
Field Strength	3V/m rms voltage level of the unmodulated signal	
Modulation	AM modulated to a depth of 80% by a sine wave of <input checked="" type="checkbox"/> 1 kHz, <input type="checkbox"/> 400 Hz (note 1)	
Dwell time	≤5 Sec.	

Note 1: The 1 kHz modulation may be replaced by a different audio modulation frequency more appropriate for a given EUT if, for example, 1 kHz is not within the operating audio range of the EUT.

Performance criteria A description for devices with the audio output function: The measured acoustic interference ratio and/or the measured electrical interference ratio during the test shall be -20 dB or better.

For equipment with audio output function:

The acoustic measurement method was selected according to clause G6.4.1 of EN 55035.

The electrical measurement method was selected according to clause G6.4.2 of EN 55035. Performance criteria A for devices with the telephony function.

Frequency range MHz	Acoustic or electrical interference ratio	Equivalent direct measurement		
		dB(SPL)	Digital dBm0	Analogue dBm0
80 to 1000	-0 dB	75	-30	-30

Note: At the step in the frequency range, the lower limit shall be applied.
The interference ratio (electrical or acoustic) shall meet the limits in column 2; or,
The acoustic level of the demodulated audio shall be less than the limits in column 3; or
The digitally coded level of demodulated audio shall be less than limits in column 4; or,
The analogue level of the demodulated audio shall be less than the limits in column 5.

Performance criteria A description for other devices: During and after the test the EUT shall continue to operate as intended without operator intervention. No degradation of performance or loss of function is allowed below a minimum performance level specified by the manufacturer when the EUT is used as intended.

7.4. Assistant equipment used for test

Assistant equipment	Manufacturer	Model number	Description	other
Adapter	SAMSUNG	EP-TA200	Input: 100-240~, 50/60Hz, 0.5A; Output: 9V/1.67A or 5V/2A	N/A
USB cable	N/A	N/A	Length: 1.00m, Unshielded	N/A

7.5. Test Procedure

The field sensor is placed on the EUT table (0.8 meter above the ground) which is 3 meters away from the transmitting antenna. Through the signal generator, power amplifier and transmitting antenna to produce a uniformity field strength (3V/m measured by field sensor) around the EUT table from frequency range specified and records the signal generator's output level at the same time for whole measured frequency range. Then, put EUT and its simulators on the EUT turn table and keep them 3 meters away from the transmitting antenna which is mounted on an antenna tower and fixes at 1 meter height above the ground. Using the recorded signal generator's output level to measure the EUT from frequency range specified and both horizontal & vertical polarization of antenna must be set and measured. Each of the four sides of EUT must be faced this transmitting antenna and measures individually.

7.6. Test result

Test Site: DDT 4# Chamber
Ambient Condition: 22.1 °C, 55.5 %RH
According Standard: <input checked="" type="checkbox"/> EN 61000-4-3, <input checked="" type="checkbox"/> EN 55035, <input type="checkbox"/> other:

Operation Mode:	Charging mode		Test Power Supply:	AC 230V/50Hz	
Field Strength:	<input checked="" type="checkbox"/> 3V/m <input type="checkbox"/> 10V/m <input type="checkbox"/> Other:_____		Swept Frequency Range:	<input checked="" type="checkbox"/> 80MHz-1GHz <input checked="" type="checkbox"/> 1.8GHz, 2.6GHz, 3.5GHz, 5GHz <input type="checkbox"/> Other:	
Modulation:	AM <input checked="" type="checkbox"/> 1kHz <input type="checkbox"/> 400Hz <input type="checkbox"/> 100Hz		Modulation depth:	80%	
Steps:	<input checked="" type="checkbox"/> 1% <input type="checkbox"/> Other:_____		Dwell time:	<input checked="" type="checkbox"/> 1s <input type="checkbox"/> Other:_____	
EUT Position towards antenna	Antenna: Horizontal		Antenna: Vertical		Result
	Required	Observation	Required	Observation	
Front	A	A	A	A	Pass
Right	A	A	A	A	Pass
Rear	A	A	A	A	Pass
Left	A	A	A	A	Pass

Operation Mode:	Case charging mode		Test Power Supply:	AC 230V/50Hz	
Field Strength:	<input checked="" type="checkbox"/> 3V/m <input type="checkbox"/> 10V/m <input type="checkbox"/> Other:_____		Swept Frequency Range:	<input checked="" type="checkbox"/> 80MHz-1GHz <input checked="" type="checkbox"/> 1.8GHz, 2.6GHz, 3.5GHz, 5GHz <input type="checkbox"/> Other:	
Modulation:	AM <input checked="" type="checkbox"/> 1kHz <input type="checkbox"/> 400Hz <input type="checkbox"/> 100Hz		Modulation depth:	80%	
Steps:	<input checked="" type="checkbox"/> 1% <input type="checkbox"/> Other:_____		Dwell time:	<input checked="" type="checkbox"/> 1s <input type="checkbox"/> Other:_____	
EUT Position towards antenna	Antenna: Horizontal		Antenna: Vertical		Result
	Required	Observation	Required	Observation	
Front	A	A	A	A	Pass
Right	A	A	A	A	Pass
Rear	A	A	A	A	Pass
Left	A	A	A	A	Pass

Operation Mode:	Earbud charging mode		Test Power Supply:	Battery	
Field Strength:	<input checked="" type="checkbox"/> 3V/m <input type="checkbox"/> 10V/m <input type="checkbox"/> Other:_____		Swept Frequency Range:	<input checked="" type="checkbox"/> 80MHz-1GHz <input checked="" type="checkbox"/> 1.8GHz, 2.6GHz, 3.5GHz, 5GHz <input type="checkbox"/> Other:	
Modulation:	AM <input checked="" type="checkbox"/> 1kHz <input type="checkbox"/> 400Hz <input type="checkbox"/> 100Hz		Modulation depth:	80%	
Steps:	<input checked="" type="checkbox"/> 1% <input type="checkbox"/> Other:_____		Dwell time:	<input checked="" type="checkbox"/> 1s <input type="checkbox"/> Other:_____	
EUT Position towards antenna	Antenna: Horizontal		Antenna: Vertical		Result
	Required	Observation	Required	Observation	
Front	A	A	A	A	Pass
Right	A	A	A	A	Pass
Rear	A	A	A	A	Pass
Left	A	A	A	A	Pass

Observation Description:

A: Normal performance within limits specified by the manufacturer requestor or purchaser.

Test Engineer:	Franky Feng	Review By:	Harmony Zeng
Test Date:	May 17, 2023	Review Date:	May 18, 2023

7.7. Test photo



8. Electrical Fast Transients (EFT) Test

8.1. Test equipment

Equipment	Manufacturer	Model No.	Serial No.	Last Cal.	Cal. Interval
EFT Generator	EMC PARTNER	TRA3000F	TRA3000F-1502	Apr. 21, 2023	1 Year
Coupling Clamp EFT	EMC PARTNER	CN-EFT1000	103648	Apr. 21, 2023	1 Year

8.2. Block diagram of test setup

For power port (Note: if the DC network power cable may be lengths greater than 3 m, the requirement is applicable).

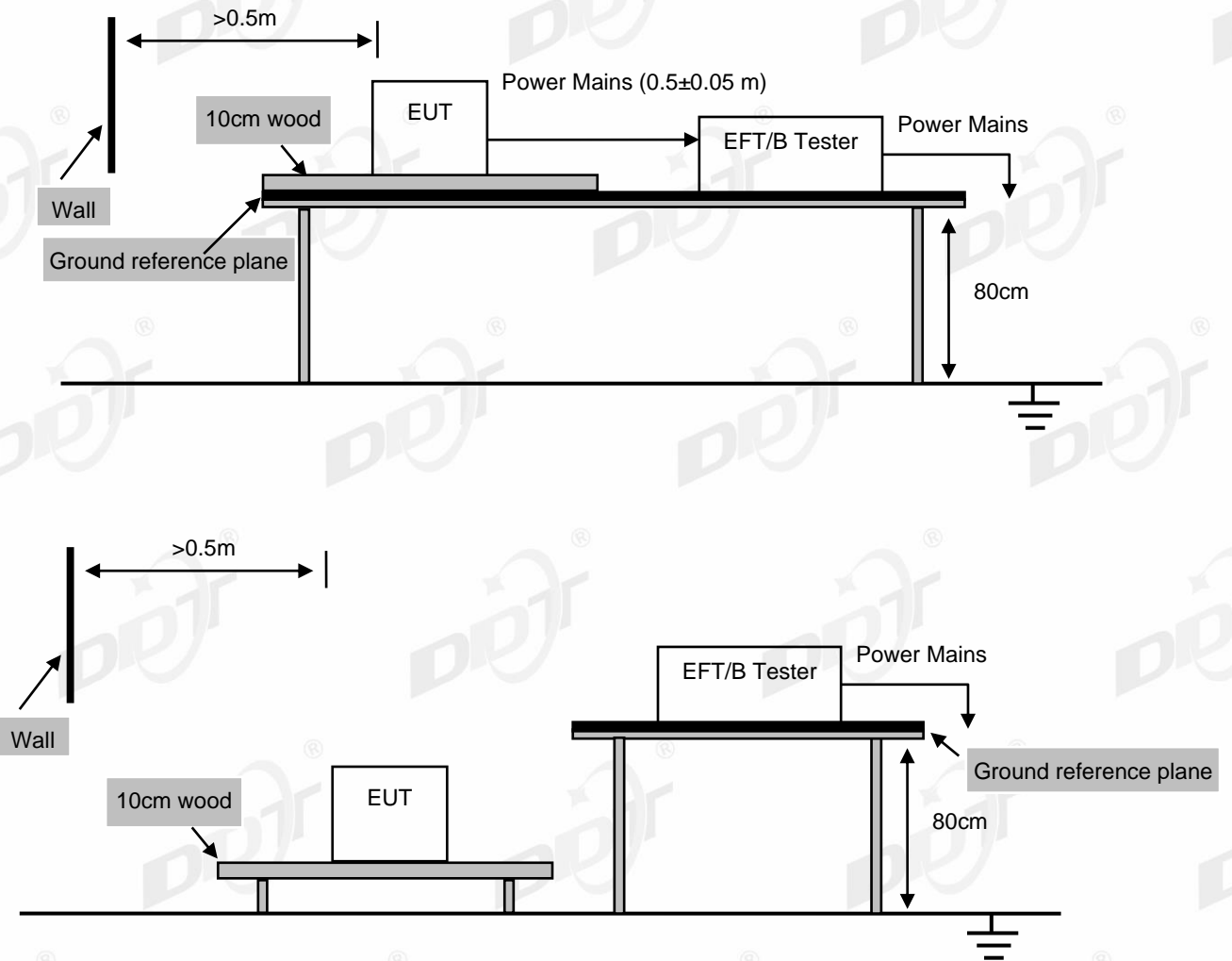

For analogue/digital data ports, if the cables may be longer than 3 m.

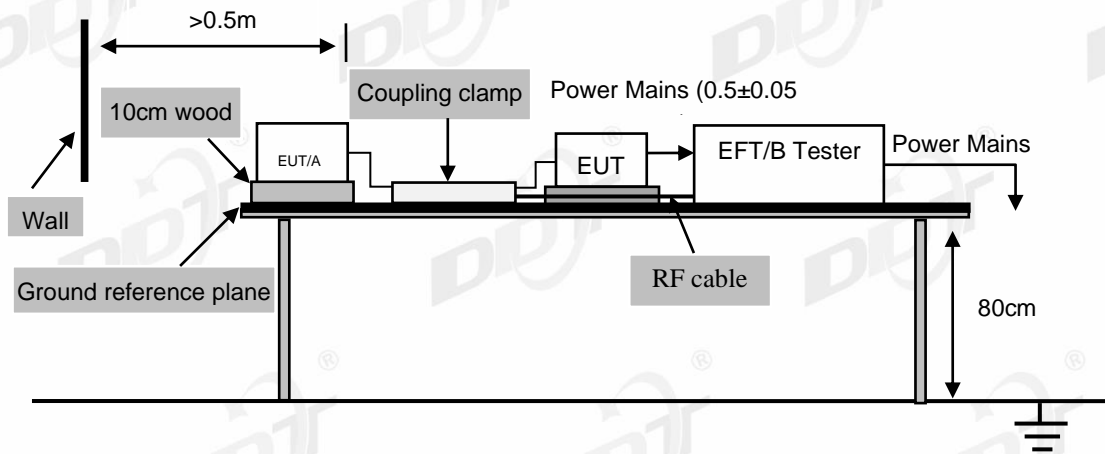

8.3. Test levels and performance criterion

Test Level			Performance Criteria
Test voltage	±1 kV for AC mains port	±0.5 kV for dc input or signal port	B
Repetition Frequency	5 kHz	5 kHz	
Burst Duration	15ms	15ms	
Burst Period	300ms	300ms	
Inject Time(s)	120s	120s	
Inject Method	Direct for AC mains port	Capacitive coupling clamp or CDN	
Inject Line	AC mains	Analogue/digital data ports, and DC network power ports	

Note: This test shall be additionally performed on analogue/digital data ports, and DC network power ports, of radio equipment and associated ancillary equipment, if the cables may be longer than 3 m.

Performance criteria B description: During the test, degradation of performance is allowed. However, no change of operating state or stored data is allowed to persist after the test. After the test, the EUT shall continue to operate as intended without operator intervention. No degradation of performance or loss of function is allowed, after the application of the phenomena below a performance level specified by the manufacturer, when the EUT is used as intended.

8.4. Assistant equipment used for test

Assistant equipment	Manufacturer	Model number	Description	other
Adapter	SAMSUNG	EP-TA200	Input: 100-240~, 50/60Hz, 0.5A; Output: 9V/1.67A or 5V/2A	N/A
USB cable	N/A	N/A	Length: 1.00m, Unshielded	N/A

8.5. Test procedure

The EUT and its simulators were placed on the ground reference plane and were insulated from it by a wood support 0.1m ± 0.01m thick. The ground reference plane was 1m*1m metallic sheet with 0.65mm minimum thickness. This reference ground plane was project beyond the EUT by at least 0.1m on all sides and the minimum distance between EUT and all other conductive structure, except the ground plane was more than 0.5m. All cables to the EUT was placed on the wood support, cables not subject to EFT/B was routed as far as possible from the cable under test to minimize the coupling between the cables.

For DC input and AC power ports:

The EUT was connected to the power mains by using a coupling device that couples the EFT interference signal to AC or DC power lines. Both positive transients and negative transients of test voltage were applied during compliance test and the duration of the test can't less than 2mins.

For analogue/digital data ports:

The capacitive coupling clamp was connected to the power by using a coupling device that couples the EFT interference signal to capacitive coupling clamp. Both positive transients and negative transients of test voltage were applied during compliance test and the duration of the test can't less than 2mins.

8.6. Test result

Test Site: DDT 7# Shield Room
Ambient Condition: <u>23.8</u> °C, <u>48.4</u> %RH
According Standard: <input checked="" type="checkbox"/> EN 61000-4-4, <input checked="" type="checkbox"/> EN 55035, <input type="checkbox"/> other:

Operation Mode:	Charging mode		Test Power Supply:	AC 230V/50Hz	
Port:	<input checked="" type="checkbox"/> AC Mains <input type="checkbox"/> DC Supply <input type="checkbox"/> Signal		Coupling:	<input checked="" type="checkbox"/> Direct <input type="checkbox"/> Capacitive Clamp	
Burst Period:	<input checked="" type="checkbox"/> 300ms <input type="checkbox"/> Other:_____		Test Time:	<input checked="" type="checkbox"/> 120s <input type="checkbox"/> Other:_____	
Repetition Frequency:	<input checked="" type="checkbox"/> 5kHz <input type="checkbox"/> Other:_____		Burst Durations:	<input checked="" type="checkbox"/> 15ms <input type="checkbox"/> Other:_____	
Line/Port	Test Voltage	Required	Observation (+)	Observation (-)	Result
L	1kV	B	A	A	Pass
N	1kV	B	A	A	Pass
L-N	1kV	B	A	A	Pass

Operation Mode:	Case charging mode		Test Power Supply:	AC 230V/50Hz	
Port:	<input checked="" type="checkbox"/> AC Mains <input type="checkbox"/> DC Supply <input type="checkbox"/> Signal		Coupling:	<input checked="" type="checkbox"/> Direct <input type="checkbox"/> Capacitive Clamp	
Burst Period:	<input checked="" type="checkbox"/> 300ms <input type="checkbox"/> Other:_____		Test Time:	<input checked="" type="checkbox"/> 120s <input type="checkbox"/> Other:_____	
Repetition Frequency:	<input checked="" type="checkbox"/> 5kHz <input type="checkbox"/> Other:_____		Burst Durations:	<input checked="" type="checkbox"/> 15ms <input type="checkbox"/> Other:_____	
Line/Port	Test Voltage	Required	Observation (+)	Observation (-)	Result
L	1kV	B	A	A	Pass
N	1kV	B	A	A	Pass
L-N	1kV	B	A	A	Pass

Observation Description:

A: Normal performance within limits specified by the manufacturer requestor or purchaser.

Test Engineer:	Bote Huang	Review By:	Harmony Zeng
Test Date:	May 17, 2023	Review Date:	May 18, 2023

8.7. Test photo

9. Surges test

9.1. Test equipment

Equipment	Manufacturer	Model No.	Serial No.	Last Cal.	Cal. Interval
Surge Generator	EMC PARTNER	TRANSIENT2000	MIG0603IN2 S-T-1504	Apr. 21, 2023	1 Year
Coupling/Decoupling Network for communication port	EMC PARTNER	CDN-UTP8 ED3	1557	Aug. 27, 2022	1 Year
Coupling/Decoupling Network for signal port	EMC PARTNER	CDN-KIT1000	CDN-KIT1000-1510	Apr. 24, 2023	1 Year

9.2. Block diagram of test setup

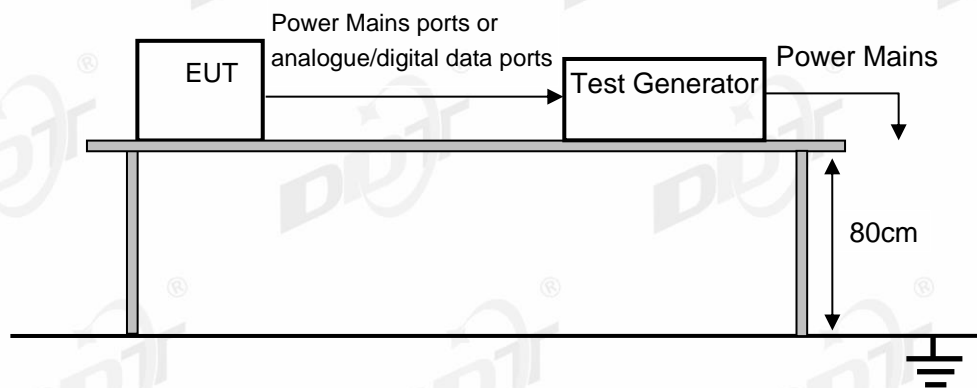

9.3. Test levels and performance criterion

Test level for AC mains ports		Performance Criterion
Line to Line	1 kV 1.2/50(8/20) μ s	B
Line to Ground	2 kV 1.2/50(8/20) μ s	B
Analogue/digital data port, Port type: unshielded symmetrical		Performance Criterion
Line to Ground	1 kV and 4 kV 10/700(5/320) μ s (used with the primary protection)	C
Line to Ground	1 kV 10/700(5/320) μ s (used without the primary protection)	C
Note: Applicable only to ports which, according to the manufacturer's specification, the cable lengths greater than 3m.		
Analogue/digital data port, Port type: coaxial or shielded		Performance Criterion
Shield to ground	0.5 kV 1.2/50(8/20) μ s	B
Note: Applicable only to ports which, according to the manufacturer's specification, the cable lengths greater than 3m.		
DC network power port		Performance Criterion
Line to reference ground	0.5 kV 1.2/50(8/20) μ s	B

Note: Applicable only to ports which, according to the manufacturer's specification, 1. The cable lengths greater than 3m; 2. May connect directly to outdoor cables.

Performance criteria B description: During the test, degradation of performance is allowed. However, no change of operating state or stored data is allowed to persist after the test. After the test, the EUT shall continue to operate as intended without operator intervention. No degradation of performance or loss of function is allowed, after the application of the phenomena below a performance level specified by the manufacturer, when the EUT is used as intended.

9.4. Assistant equipment used for test

Assistant equipment	Manufacturer	Model number	Description	other
Adapter	SAMSUNG	EP-TA200	Input: 100-240~, 50/60Hz, 0.5A; Output: 9V/1.67A or 5V/2A	N/A
USB cable	N/A	N/A	Length: 1.00m, Unshielded	N/A

9.5. Test procedure

For line-to-neutral coupling mode, provide a 0.5 kV/1 kV 1.2/50 us voltage surge (at open-circuit condition) and 8/20 us current surge to EUT selected points.

For line-to-ground coupling mode, provide a 0.5 kV/1 kV/2 kV 1.2/50 us voltage surge (at open-circuit condition) and 8/20 us current surge to EUT selected points.

The number of pulses applied shall be as follows:

- Five positive pulses line-to-neutral at 90° phase
- Five negative pulses line-to-neutral at 270° phase

The following additional pulses are required only if the EUT has an earth connection or if the EUT is earthed via any AE.

- Five positive pulses line-to-earth at 90° phase
- Five negative pulses line-to-earth at 270° phase
- Five negative pulses neutral-to-earth at 90° phase
- Five positive pulses neutral-to-earth at 270° phase

Maximum 1/min repetition rate are applied during test.

Different phase angles are done individually.

For telecommunication surge test, each line of internet port to ground coupling mode, provide a 1.0 kV 10/700 us voltage surge (at open-circuit condition) and 5/320us current surge to EUT selected points.

At least 5 positive and 5 negative (polarity) tests with a maximum 1/min repetition rate are applied during test.

Record the EUT operating situation during compliance test and decide the EUT immunity criterion for above each test.

9.6. Test result

Test Site: DDT Surges Room
Ambient Condition: 23.4 °C, 54.5 %RH
According Standard: <input checked="" type="checkbox"/> EN 61000-4-5, <input checked="" type="checkbox"/> EN 55035, <input type="checkbox"/> other:

Operation Mode:	Charging mode	Test Power Supply:	AC 230V/50Hz		
Line:	<input checked="" type="checkbox"/> AC Mains <input type="checkbox"/> DC Supply <input type="checkbox"/> Signal port <input type="checkbox"/> Telecommunication port	Wave Type:	<input checked="" type="checkbox"/> 1.2/50us-8/20us <input type="checkbox"/> 10/700 us-5/320us		
Internal impedance:	<input checked="" type="checkbox"/> 2Ω <input type="checkbox"/> 12Ω <input type="checkbox"/> 25Ω <input type="checkbox"/> 40Ω <input type="checkbox"/> 42Ω <input type="checkbox"/> Other:	Voltage Phase:	<input checked="" type="checkbox"/> 90°, 270° <input type="checkbox"/> 0°, 90°, 180°, 270° <input type="checkbox"/> ±		
Pluse times:	5 times at each polarity	Pulse Interval:	60s		
Line/Port	Test Voltage	Required	Observation (+)	Observation (-)	Result
L-N	0.5kV	B	A	A	Pass
L-N	1kV	B	A	A	Pass

Operation Mode:	Case charging mode	Test Power Supply:	AC 230V/50Hz		
Line:	<input checked="" type="checkbox"/> AC Mains <input type="checkbox"/> DC Supply <input type="checkbox"/> Signal port <input type="checkbox"/> Telecommunication port	Wave Type:	<input checked="" type="checkbox"/> 1.2/50us-8/20us <input type="checkbox"/> 10/700 us-5/320us		
Internal impedance:	<input checked="" type="checkbox"/> 2Ω <input type="checkbox"/> 12Ω <input type="checkbox"/> 25Ω <input type="checkbox"/> 40Ω <input type="checkbox"/> 42Ω <input type="checkbox"/> Other:	Voltage Phase:	<input checked="" type="checkbox"/> 90°, 270° <input type="checkbox"/> 0°, 90°, 180°, 270° <input type="checkbox"/> ±		
Pluse times:	5 times at each polarity	Pulse Interval:	60s		
Line/Port	Test Voltage	Required	Observation (+)	Observation (-)	Result
L-N	0.5kV	B	A	A	Pass
L-N	1kV	B	A	A	Pass

Observation Description:

A: Normal performance within limits specified by the manufacturer requestor or purchaser.

Test Engineer:	Bote Huang	Review By:	Harmony Zeng
Test Date:	May 17, 2023	Review Date:	May 18, 2023

9.7. Test photo



10. Continuous Conducted Disturbances

10.1. Test equipment

Equipment	Manufacturer	Model No.	Serial No.	Last Cal.	Cal. Interval
Audio Analyzer	R&S	UPL16	100167	Apr. 21, 2023	1 Year
Conducted Immunity Tester	FRANKONIA	CIT-10	126B1207	Apr. 23, 2023	1 Year
CDN	FRANKONIA	CDNT8	A6100017/2012	Aug. 27, 2022	1 Year
CDN	SCHWARZBECK	CDN M2+M3PE 16A	00058	Aug. 27, 2022	1 Year
CDN	SHANGHAI LIONCEL	CDN M3-32	191001	Aug. 27, 2022	1 Year
EM Clamp	FRANKONIA	EMCL	132A1143/2012	Aug. 27, 2022	1 Year
Attenuation	BIRD	DAM75W (6dB)	1143	Aug. 27, 2022	1 Year
Test Software	SKET	EMC-S	V1.2.0.80	N/A	N/A

Note: N/A means not applicable.

10.2. Block diagram of test setup

For power port (Note: if the DC network power cable may be lengths greater than 3 m, the requirement is applicable).

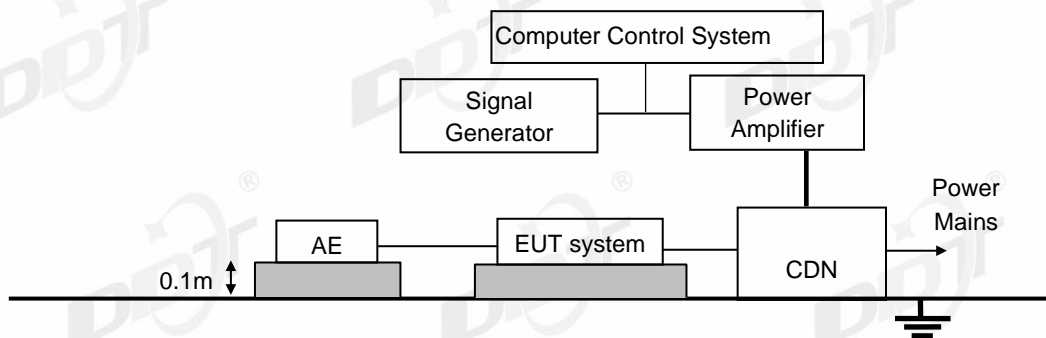

For analogue/digital data ports, if the cables may be longer than 3 m.

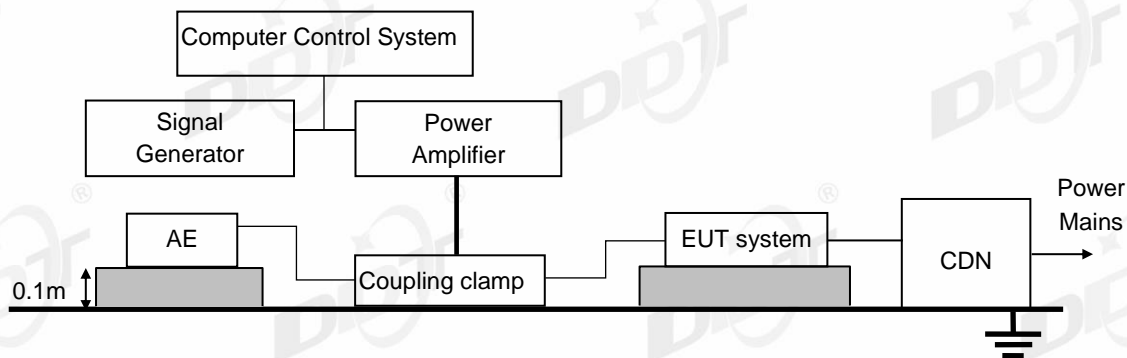

For audio output function (electrical measurement, direct connection to EUT)

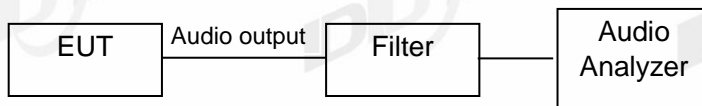

For audio output function (acoustic measurement)

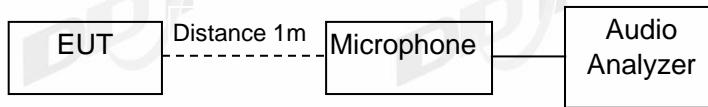

For audio output function (on-ear acoustic measurement)

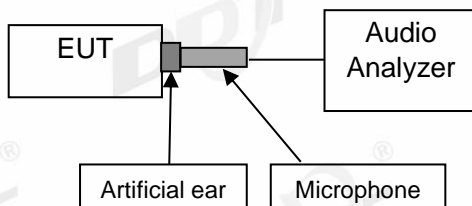

10.3. Test levels and performance criterion

Test Level		Performance Criteria
Frequency and Field Strength	0.15 MHz to 10 MHz, 3V rms voltage level of the unmodulated signal	A
	10 MHz to 30 MHz, 3V to 1V rms voltage level of the unmodulated signal	
	30 MHz to 80 MHz, 1V rms voltage level of the unmodulated signal	
Modulation	AM modulated to a depth of 80% by a sine wave of ☒ 1 kHz, ☐ 400 Hz (note 1)	
Step Size	1% increments	
Dwell time	≤5 Sec.	

Note 1: The 1 kHz modulation may be replaced by a different audio modulation frequency more appropriate for a given EUT if, for example, 1 kHz is not within the operating audio range of the EUT.

Note 2: This test shall be additionally performed on analogue/digital data ports, DC network power ports of equipment, if the cables may be longer than 3 m.

Performance criteria A description for devices with the audio output function: The measured acoustic interference ratio and/or the measured electrical interference ratio during the test shall be -20 dB or better.

- The acoustic measurement method was selected according to clause G6.4.1 of EN 55035.
- The electrical measurement method was selected according to clause G6.4.2 of EN 55035.

Performance criteria A for devices with the telephony function.

Frequency range MHz	Acoustic or electrical interference ratio	Equivalent direct measurement		
		dB(SPL)	Digital dBm0	Analogue dBm0
0.15 to 30	-20 dB	55	-50	-50
30 to 80	-10 dB	65	-40	-40

Note: At the step in the frequency range, the lower limit shall be applied.

The interference ratio (electrical or acoustic) shall meet the limits in column 2; or,

The acoustic level of the demodulated audio shall be less than the limits in column 3; or
 The digitally coded level of demodulated audio shall be less than limits in column 4; or,
 The analogue level of the demodulated audio shall be less than the limits in column 5.

Performance criteria A description for other devices: During and after the test the EUT shall continue to operate as intended without operator intervention. No degradation of performance or loss of function is allowed below a minimum performance level specified by the manufacturer when the EUT is used as intended.

10.4. Assistant equipment used for test

Assistant equipment	Manufacturer	Model number	Description	other
Adapter	SAMSUNG	EP-TA200	Input: 100-240~, 50/60Hz, 0.5A; Output: 9V/1.67A or 5V/2A	N/A
USB cable	N/A	N/A	Length: 1.00m, Unshielded	N/A

10.5. Test procedure

The EUT are placed on an insulating support 0.1m high above a ground reference plane. CDN (coupling and decoupling device) is placed on the ground plane about 0.3m from EUT. Cables between CDN and EUT are as short as possible, and their height above the ground reference plane shall be between 30 and 50 mm (where possible).

The disturbance signal described below is injected to EUT through CDN.

The EUT operates within its operational mode(s) under intended climatic conditions after power on. The frequency range is swept from 0.15 MHz to 80 MHz, the interference signal level according to standard, and with the disturbance signal 80% amplitude modulated with a \square 1 kHz/ \square 400 Hz sine wave.

The step size shall not exceed 1% of the start and thereafter 1% of the preceding frequency value.

Recording the EUT operating situation during compliance testing and decide the EUT immunity criterion.

10.6. Test result

Test Site: DDT Continuous Conducted Disturbances Room
Ambient Condition: 21.3 °C, 50.8 %RH
According Standard: <input checked="" type="checkbox"/> EN 61000-4-6, <input checked="" type="checkbox"/> EN 55035, <input type="checkbox"/> other:

Operation Mode:	Charging mode		Test Power Supply:	AC 230V/50Hz	
Port:	<input checked="" type="checkbox"/> AC Mains <input type="checkbox"/> DC Supply <input type="checkbox"/> Signal		Coupling:	<input checked="" type="checkbox"/> Direct <input type="checkbox"/> EM Clamps	
Modulation:	<input checked="" type="checkbox"/> 1kHz <input type="checkbox"/> 400Hz <input type="checkbox"/> 100Hz <input checked="" type="checkbox"/> AM		Modulation depth:	80%	
Steps:	<input checked="" type="checkbox"/> 1% <input type="checkbox"/> Other:_____		Dwell time:	<input checked="" type="checkbox"/> 1s <input type="checkbox"/> Other:_____	
Frequency Range	Injected Position	Strength	Required	Observation	Result
0.15MHz-10MHz	AC port	3V	A	A	Pass
10MHz-30MHz		3V-1V	A	A	Pass
30MHz-80MHz		1V	A	A	Pass

Operation Mode:	Case charging mode		Test Power Supply:	AC 230V/50Hz	
Port:	<input checked="" type="checkbox"/> AC Mains <input type="checkbox"/> DC Supply <input type="checkbox"/> Signal		Coupling:	<input checked="" type="checkbox"/> Direct <input type="checkbox"/> EM Clamps	
Modulation:	<input checked="" type="checkbox"/> 1kHz <input type="checkbox"/> 400Hz <input type="checkbox"/> 100Hz <input checked="" type="checkbox"/> AM		Modulation depth:	80%	
Steps:	<input checked="" type="checkbox"/> 1% <input type="checkbox"/> Other:_____		Dwell time:	<input checked="" type="checkbox"/> 1s <input type="checkbox"/> Other:_____	
Frequency Range	Injected Position	Strength	Required	Observation	Result
0.15MHz-10MHz	AC port	3V	A	A	Pass
10MHz-30MHz		3V-1V	A	A	Pass
30MHz-80MHz		1V	A	A	Pass

Observation Description:

A: Normal performance within limits specified by the manufacturer requestor or purchaser.

Test Engineer:	Franky Feng	Review By:	Harmony Zeng
Test Date:	May 18, 2023	Review Date:	May 18, 2023

10.7. Test photo

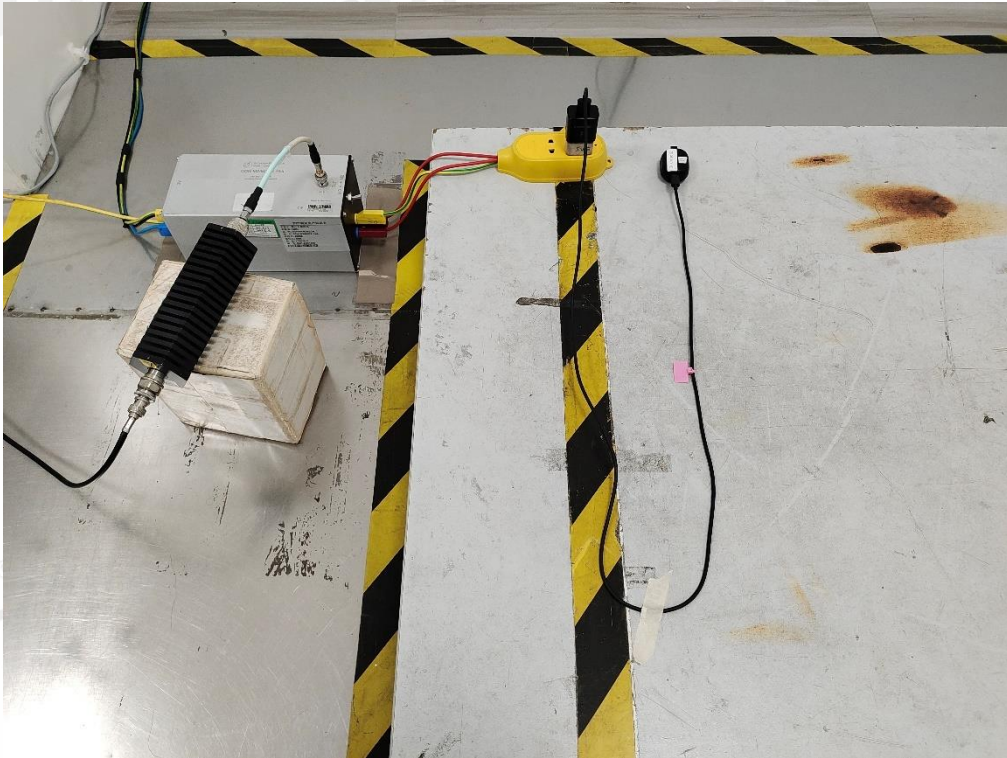

11. Power-Frequency Magnetic Fields

11.1. Test equipment

Equipment	Manufacturer	Model No.	Serial No.	Last Cal.	Cal. Interval
EFT Generator	EMC PARTNER	TRA3000F	TRA3000F-1502	Apr. 21, 2023	1Year
Magnetic Field Tester	EMC PARTNER	MF1000-1	207	Aug. 26, 2022	1Year

11.2. Block diagram of test setup

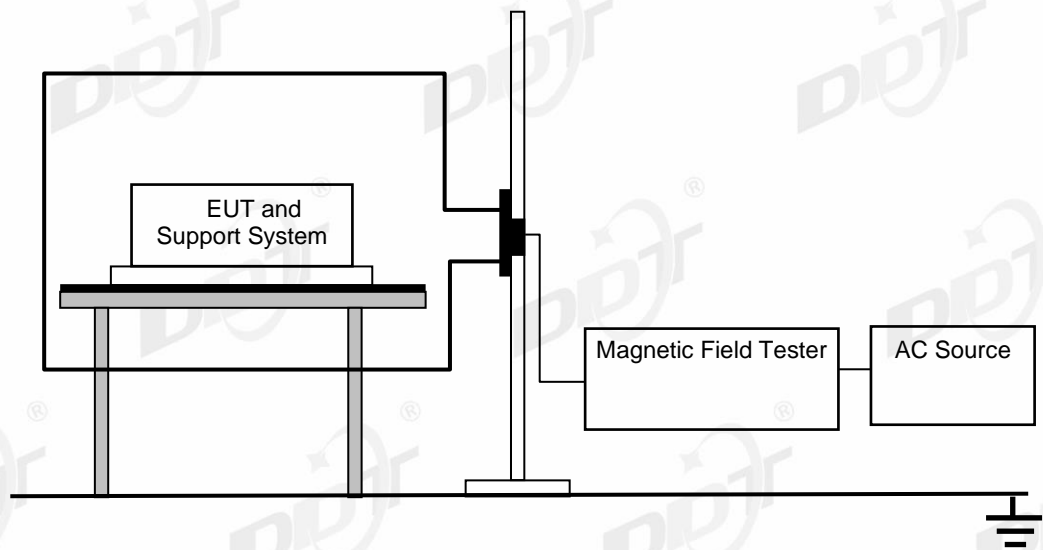

11.3. Test levels and performance criterion

Level	Magnetic Field Strength (A/m)	Performance Criterion
1	1	A

Performance criteria A description: During and after the test the EUT shall continue to operate as intended without operator intervention. No degradation of performance or loss of function is allowed below a minimum performance level specified by the manufacturer when the EUT is used as intended.

11.4. Assistant equipment used for test

Assistant equipment	Manufacturer	Model number	Description	other
Adapter	SAMSUNG	EP-TA200	Input: 100-240~, 50/60Hz, 0.5A; Output: 9V/1.67A or 5V/2A	N/A
USB cable	N/A	N/A	Length: 1.00m, Unshielded	N/A

11.5. Test procedure

The EUT shall be subjected to the test magnetic field by using the induction coil of standard dimensions (1m*1m). Then induction coil shall then be rotated by 90° in order to expose the EUT to the test field with different orientations.

11.6. Test result

Test Site: DDT 7# Shield Room
Ambient Condition: 23.7 °C, 48.4 %RH
According Standard: <input checked="" type="checkbox"/> EN 61000-4-8, <input checked="" type="checkbox"/> EN 55035, <input type="checkbox"/> other:

Operation Mode:	Charging mode	Test Power Supply:	AC 230V/50Hz
Test Level:	<input checked="" type="checkbox"/> 1A/m <input type="checkbox"/> 3A/m <input type="checkbox"/> Other: <input checked="" type="checkbox"/> 50Hz <input type="checkbox"/> 60Hz	Testing Duration:	<input checked="" type="checkbox"/> 300s <input type="checkbox"/> Other:
Coil Orientation	Required	Observation	Result
X	A	A	Pass
Y	A	A	Pass
Z	A	A	Pass

Operation Mode:	Case charging mode	Test Power Supply:	AC 230V/50Hz
Test Level:	<input checked="" type="checkbox"/> 1A/m <input type="checkbox"/> 3A/m <input type="checkbox"/> Other: <input checked="" type="checkbox"/> 50Hz <input type="checkbox"/> 60Hz	Testing Duration:	<input checked="" type="checkbox"/> 300s <input type="checkbox"/> Other:
Coil Orientation	Required	Observation	Result
X	A	A	Pass
Y	A	A	Pass
Z	A	A	Pass

Operation Mode:	Earbud charging mode	Test Power Supply:	Battery
Test Level:	<input checked="" type="checkbox"/> 1A/m <input type="checkbox"/> 3A/m <input type="checkbox"/> Other: <input checked="" type="checkbox"/> 50Hz <input type="checkbox"/> 60Hz	Testing Duration:	<input checked="" type="checkbox"/> 300s <input type="checkbox"/> Other:
Coil Orientation	Required	Observation	Result
X	A	A	Pass
Y	A	A	Pass
Z	A	A	Pass

Observation Description:

A: Operation as intend no loss of function during test and after test.

Test Engineer:	Bote Huang	Review By:	Harmony Zeng
Test Date:	May 17, 2023	Review Date:	May 18, 2023

11.7. Test photo

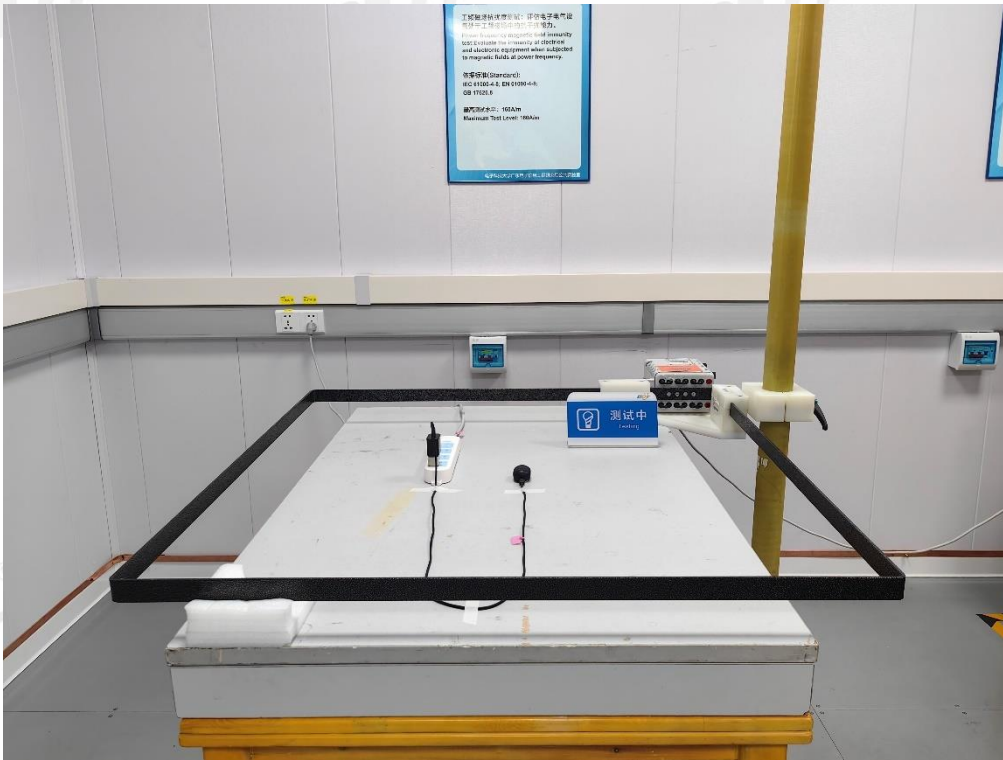

12. Voltage Dips and Interruptions

12.1. Test Equipment

Equipment	Manufacturer	Model No.	Serial No.	Last Cal.	Cal. Interval
EFT Generator	EMC PARTNER	TRA3000F	TRA3000F-1502	Apr. 21, 2023	1Year
DIPS TESTER	EMC PARTNER	EXT-TRA3000D	EXT-TRA3000D-1510	Apr. 21, 2023	1Year

12.2. Block diagram of test setup

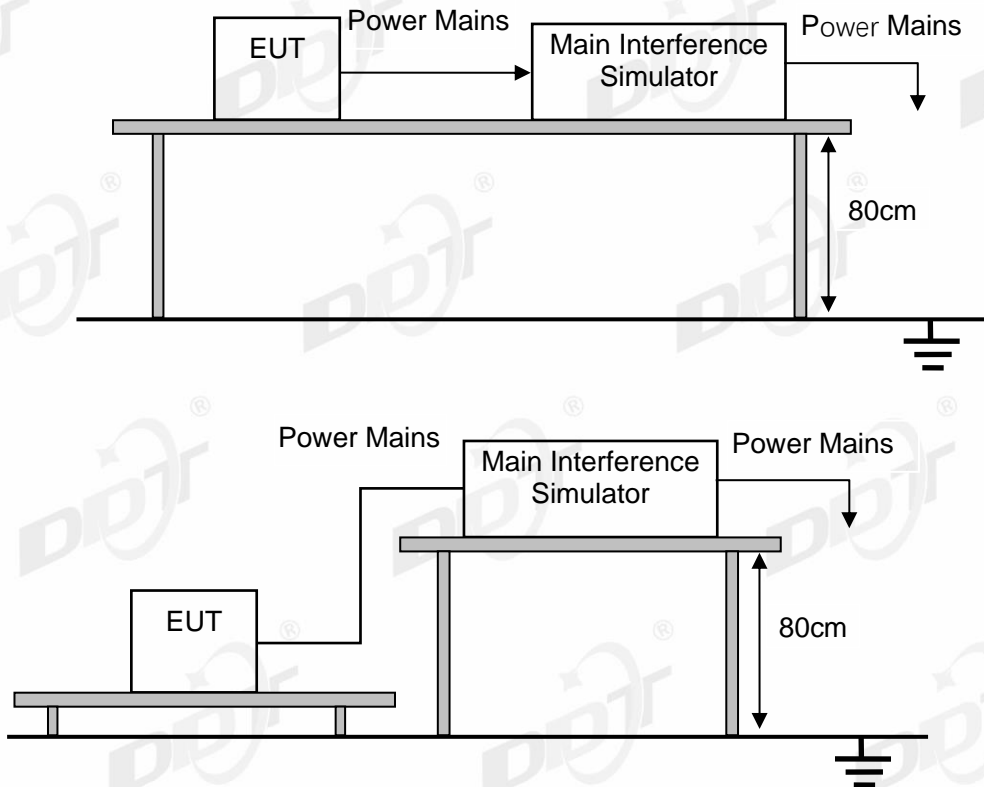

12.3. Test levels and performance criterion

Test Level %UT	Duration (in period)	Performance Criterion
<5	0.5	B
70	25 for 50 Hz/30 for 60 Hz	C
<5	250 for 50 Hz/300 for 60 Hz	C

Performance criteria B description: During the test, degradation of performance is allowed. However, no change of operating state or stored data is allowed to persist after the test. After the test, the EUT shall continue to operate as intended without operator intervention. No degradation of performance or loss of function is allowed, after the application of the phenomena below a performance level specified by the manufacturer, when the EUT is used as intended.

Performance criteria C description: During and after testing, a temporary loss of function is allowed, provided the function is self recoverable, or can be restored by the operation of the controls or cycling of the power to the EUT by the user in accordance with the manufacturer's instructions. Functions, and/or information stored in non-volatile memory, or protected by a battery backup, shall not be lost.

12.4. Assistant equipment used for test

Assistant equipment	Manufacturer	Model number	Description	other
Adapter	SAMSUNG	EP-TA200	Input: 100-240~, 50/60Hz, 0.5A; Output: 9V/1.67A or 5V/2A	N/A
USB cable	N/A	N/A	Length: 1.00m, Unshielded	N/A

12.5. Test Procedure

The EUT and test generator were setup as shown. The interruptions are introduced at selected phase angles with specified duration. Record any degradation of performance.

Note: Changes to occur at 0 degree crossover point of the voltage waveform. If the EUT does not demonstrate compliance when tested with 0 degree switching, the test shall be repeated with the switching occurring at both 90 degrees and 270 degrees. If the EUT satisfies these alternative requirements, then it fulfils the requirements.

12.6. Test result

Test Site: DDT 7# Shield Room
Ambient Condition: 23.7 °C, 48.4 %RH
According Standard: <input checked="" type="checkbox"/> EN 61000-4-11, <input checked="" type="checkbox"/> EN 55035, <input type="checkbox"/> other:

Operation Mode:	Charging mode		Test Power Supply:		AC 240V/50Hz
Voltage Dips & Short Interruptions %Ur	Duration (in period)	Phase Angle	Required	Observation	Result
0	0.5P	0° to 360°	B	A	Pass
70	25P	0° to 360°	C	A	Pass
0	250P	0° to 360°	C	B	Pass

Operation Mode:	Charging mode		Test Power Supply:		AC 100V/60Hz
Voltage Dips & Short Interruptions %Ur	Duration (in period)	Phase Angle	Required	Observation	Result
0	0.5P	0° to 360°	B	A	Pass
70	30P	0° to 360°	C	A	Pass
0	300P	0° to 360°	C	B	Pass

Operation Mode:	Case charging mode		Test Power Supply:		AC 240V/50Hz
Voltage Dips & Short Interruptions %Ur	Duration (in period)	Phase Angle	Required	Observation	Result
0	0.5P	0° to 360°	B	A	Pass
70	25P	0° to 360°	C	A	Pass
0	250P	0° to 360°	C	B	Pass

Operation Mode:	Case charging mode		Test Power Supply:	AC 100V/60Hz	
Voltage Dips & Short Interruptions %Ur	Duration (in period)	Phase Angle	Required	Observation	Result
0	0.5P	0° to 360°	B	A	Pass
70	30P	0° to 360°	C	A	Pass
0	300P	0° to 360°	C	B	Pass

Observation Description:

A: Operation as intend no loss of function during test and after test;

B: The EUT stops charging and recovers by itself.

Test Engineer:	Bote Huang	Review By:	Harmony Zeng
Test Date:	May 17,2023	Review Date:	May 18, 2023

12.7. Test photo



13. Photos of The EUT

Please refer to appendix I

END OF REPORT