

# EMC TEST REPORT

On Behalf of

Prepared For :	<b>Dongyang Xiaoqi Industry and Trade Co., Ltd.</b> 3rd floor 77 Maxiang Road, Lantian community, Baiyun Street, Dongyang City, jinhua City, Zhejiang Province
Trade Mark :	<b>N/A</b>
Product Name :	<b>Fascia Gun</b>
Model(s) :	<b>7017, 1028</b>
Prepared By:	<b>Shenzhen ZTS Testing Service Co., Ltd.</b> 808, Building 1, 7th Industrial Zone, Yulv Community, Yutang Street, Guangming District, Shenzhen, Guangdong, China Tel: 400-8788-298      Tel:0755-23245950 Email: zts@zts-test.com      Web: www.zts-test.com
Test Date:	<b>Aug. 30, 2021 - Sep. 04, 2021</b>
Date of Report:	<b>Sep. 04, 2021</b>
Report No. :	<b>ZTS21083005XRE</b>



**Note:** This test report is limited to the above client company and the product model only. It may not be duplicated without prior written consent of Shenzhen ZTS Testing Service Co., Ltd



## TABLE OF CONTENTS

<b>1. GENERAL INFORMATION.....</b>	<b>5</b>
1.1 PRODUCT DESCRIPTION FOR EQUIPMENT UNDER TEST (EUT).....	5
1.2 TEST STANDARDS.....	5
1.3 TEST SUMMARY .....	6
1.4 TEST METHODOLOGY.....	7
1.5 TEST FACILITY.....	7
1.6 TEST EQUIPMENT LIST AND DETAILS.....	8
<b>2. SYSTEM TEST CONFIGURATION .....</b>	<b>10</b>
2.1 JUSTIFICATION .....	10
2.2 EUT EXERCISE SOFTWARE .....	10
2.3 SPECIAL ACCESSORIES .....	10
2.4 EQUIPMENT MODIFICATIONS .....	10
2.5 CONFIGURATION OF TEST SYSTEM.....	10
2.6 TEST SETUP DIAGRAM .....	10
<b>3. DISTURBANCE VOLTAGE AT THE MAINS TERMINALS .....</b>	<b>11</b>
3.1 MEASUREMENT UNCERTAINTY .....	11
3.2 LIMIT OF DISTURBANCE VOLTAGE AT THE MAINS TERMINALS.....	11
3.3 EUT SETUP .....	11
3.4 INSTRUMENTS SETUP.....	12
3.5 TEST PROCEDURE .....	12
3.6 SUMMARY OF TEST RESULTS.....	12
3.7 DISTURBANCE VOLTAGE TEST DATA.....	12
3.8 TEST RESULT.....	12
<b>4. DISCONTINUOUS DISTURBANCE (CLICK).....</b>	<b>13</b>
4.1 LIMIT OF DISCONTINUOUS DISTURBANCE.....	13
4.2 EUT SETUP .....	13
4.3 TEST PROCEDURE .....	13
4.4 SUMMARY OF TEST RESULTS.....	13
4.5 DISTURBANCE VOLTAGE TEST DATA.....	13
4.6 TEST RESULT.....	13
<b>5. DISTURBANCE POWER .....</b>	<b>14</b>
5.1 MEASUREMENT UNCERTAINTY .....	14
5.2 LIMIT OF DISTURBANCE POWER .....	14
5.3 EUT SETUP .....	14
5.4 INSTRUMENTS SETUP.....	15
5.5 TEST PROCEDURE .....	15
5.6 DISTURBANCE POWER TEST DATA .....	15
5.7 TEST PLOT(S) FOR DISTURBANCE POWER.....	15
5.8 TEST RESULT.....	15
<b>6. RADIATED EMISSION MEASUREMENT .....</b>	<b>16</b>
6.1 BLOCK DIAGRAM OF TEST .....	16
6.2 MEASURING STANDARD .....	16
6.3 RADIATED EMISSION LIMITS.....	17
6.4 EUT CONFIGURATION ON TEST .....	17
6.5 OPERATING CONDITION OF EUT .....	17
6.6 TEST PROCEDURE.....	17
6.7 MEASURING RESULTS.....	17
<b>7. ELECTROSTATIC DISCHARGE IMMUNITY TEST (EN 61000-4-2).....</b>	<b>20</b>
7.1 BLOCK DIAGRAM OF TEST SETUP.....	20
7.2 TEST STANDARD .....	20
7.3 SEVERITY LEVELS AND PERFORMANCE CRITERION .....	20
7.4 OPERATING CONDITION OF EUT .....	20
7.5 TEST PROCEDURE.....	21
7.6 TEST RESULTS.....	21
<b>8.0 RF FIELD STRENGTH SUSCEPTIBILITY TEST.....</b>	<b>22</b>
8.1 BLOCK DIAGRAM OF TEST.....	22
8.2 TEST STANDARD .....	22



8.3 SEVERITY LEVELS AND PERFORMANCE CRITERION .....23

8.4 EUT CONFIGURATION ON TEST.....23

8.5 OPERATING CONDITION OF EUT .....23

8.6 TEST PROCEDURE.....23

8.7 TEST RESULTS.....23

**9. ELECTRICAL FAST TRANSIENT/BURST IMMUNITY TEST (EN 61000-4-4) ..... 24**

9.1 BLOCK DIAGRAM OF TEST SETUP.....24

9.2 TEST STANDARD .....24

9.3 SEVERITY LEVELS AND PERFORMANCE CRITERION .....24

9.4 OPERATING CONDITION OF EUT .....24

9.5 TEST PROCEDURE.....25

9.6 TEST RESULT.....25

**10. SURGE IMMUNITY TEST (EN 61000-4-5)..... 26**

10.1 BLOCK DIAGRAM OF TEST SETUP.....26

10.2 TEST STANDARD .....26

10.3 SEVERITY LEVELS AND PERFORMANCE CRITERION .....26

10.4 OPERATING CONDITION OF EUT .....26

10.5 TEST PROCEDURE.....27

10.6 TEST RESULT.....27

**11. CONDUCTED SUSCEPTIBILITY TEST (EN 61000-4-6)..... 28**

11.1 BLOCK DIAGRAM OF TEST SETUP.....28

11.2 TEST STANDARD .....28

11.3 SEVERITY LEVELS AND PERFORMANCE CRITERION .....28

11.4 OPERATING CONDITION OF EUT .....28

11.5 TEST PROCEDURE.....29

11.6 TEST RESULTS.....29

**12. VOLTAGE DIPS, SHORT INTERRUPTIONS IMMUNITY TESTS (EN61000-4-11) ..... 30**

12.1 BLOCK DIAGRAM OF TEST SETUP.....30

12.2 TEST STANDARD .....30

12.3 SEVERITY LEVELS AND PERFORMANCE CRITERION .....30

12.4 EUT CONFIGURATION.....30

12.5 OPERATING CONDITION OF EUT .....30

12.6 TEST PROCEDURE.....31

12.7 TEST RESULT.....31

**13. TEST RESULTS..... 32**

13.1 EN 61000-4-2 ELECTROSTATIC DISCHARGE IMMUNITY TEST CONFIGURATION.....32

13.2 EN 61000-4-3 ELECTROSTATIC DISCHARGE IMMUNITY TEST CONFIGURATION.....32

13.3 EN 61000-4-4 ELECTRICAL FAST TRANSIENT/BURST IMMUNITY TEST CONFIGURATION .....32

13.4 EN 61000-4-5 SURGE IMMUNITY TEST CONFIGURATION.....32

13.5 EN 61000-4-6 CONDUCTED SUSCEPTIBILITY TEST CONFIGURATION.....32

13.6 EN 61000-4-11 VOLTAGE DIPS, SHORT INTERRUPTIONS IMMUNITY TESTS CONFIGURATION .....32

**APPENDIX A - PRODUCT LABELING ..... 33**

CE MARK LABEL SPECIFICATION .....33

**APPENDIX B- EUT PHOTOGRAPHS ..... 34**

## TEST REPORT DECLARATION

Applicant	:	<b>Dongyang Xiaoqi Industry and Trade Co., Ltd.</b>
Address :	:	3rd floor 77 Maxiang Road, Lantian community, Baiyun Street, Dongyang City, jinhua City, Zhejiang Province
Manufacturer:	:	<b>Dongyang Xiaoqi Industry and Trade Co., Ltd.</b>
Address :	:	3rd floor 77 Maxiang Road, Lantian community, Baiyun Street, Dongyang City, jinhua City, Zhejiang Province
EUT Description :	:	<b>Fascia Gun</b>
Model Number	:	7017

Test Standards:

**EN 55014-1: 2017+A11: 2020**  
**EN 55014-2: 2015**

The EUT described above is tested by ZTS Testing Service Co., Ltd. EMC Laboratory to determine the maximum emissions from the EUT and ensure the EUT to be compliance with the immunity requirements of the EUT. Shenzhen ZTS Testing Service Co., Ltd. is assumed full responsibility for the accuracy of the test results. Also, this report shows that the EUT technically complies with the 2014/30/EU directive and its amendment requirements.

The test report is valid for above tested sample only and shall not be reproduced in part without written approval of the laboratory.

Date of Test:

**Aug. 30, 2021 - Sep. 04, 2021**

Prepared by (Engineer) :

Junny He

Reviewer by (Quality Manager) :

Tony Mo

Approved by (Manager) :

Bart Tang



## 1. GENERAL INFORMATION

---

### 1.1 Product Description for Equipment Under Test (EUT)

#### Client Information

Applicant: Dongyang Xiaoqi Industry and Trade Co., Ltd.  
Address of applicant: 3rd floor 77 Maxiang Road, Lantian community, Baiyun Street, Dongyang City, jinhua City, Zhejiang Province  
Manufacturer: Dongyang Xiaoqi Industry and Trade Co., Ltd.  
Address of manufacturer: 3rd floor 77 Maxiang Road, Lantian community, Baiyun Street, Dongyang City, jinhua City, Zhejiang Province

#### General Description of E.U.T

EUT Description: Fascia Gun  
Trade Mark: N/A  
EUT Model No.: 7017  
Rating: DC 25.2V 1A, 30W  
Test Voltage: DC 25.2V 1A, 30W

#### Remark:

- The test data gathered are from the production sample provided by the manufacturer.
- The length of power line is 1.8m

### 1.2 Test Standards

The following Declaration of Conformity report of EUT is prepared in accordance with

EN 55014-1: 2017+A11: 2020

EN 55014-2: 2015

The objective of the manufacturer is to demonstrate compliance with the described standards above.

### 1.3 Test Summary

For the EUT described above. This apparatus is subdivided into category II according to the section 4.2 of EN 55014-2: 2015. So according to section 7.2.2 of this standard, the immunity test item applicable to this EUT is listed in table 3.

Table 1: Tests Carried Out Under EN55014-1:2006+A1:2009 + A2:2011 (as amended)

Standard	Test Items	Test Result
EN55014-1:2006+A1:2009+A2:2011	Conducted Emission, 150kHz to 30MHz	PASS
EN55014-1:2006+A1:2009+A2:2011	Disturbance Power (30MHz To 300MHz)	N/A
EN55014-1:2006+A1:2009+A2:2011	Click	N/A

- √ Indicates that the test is applicable
- × Indicates that the test is not applicable

Table 2: Tests Carried Out Under EN 55014-2: 2015

Standard	Test Items	Test Result
EN 61000-4-2: 2009	Electrostatic discharge Immunity	PASS
EN 61000-4-3: 2006 +A1:2008+A2:2010	Radiated Susceptibility (80MHz to 1GHz)	N/A
EN 61000-4-4: 2004+A1:2010	Electrical Fast Transient/Burst Immunity	N/A
EN 61000-4-5: 2006	Surge Immunity	N/A
EN 61000-4-6: 2009	Conducted Susceptibility (150kHz to 230MHz)	N/A
EN 61000-4-11: 2004	Voltage Dips, Short Interruptions Immunity	N/A

- √ Indicates that the test is applicable
- × Indicates that the test is not applicable

## 1.4 Test Methodology

All measurements contained in this report were conducted with CISPR 16-1, radio disturbance and immunity measuring apparatus, and CISPR16-2, Method of measurement of disturbances and immunity.

All measurement required was performed at laboratory of Shenzhen ZTS Testing Service Co., Ltd. .

## 1.5 Test Facility

The test facility is recognized, certified, or accredited by the following comanizations:

EMC Lab. : Accredited by FCC (Federal Communications Commission)

The Laboratory has been assessed according to the requirements ISO/IEC 17025.

Name of Firm : Shenzhen ZTS Testing Service Co., Ltd. .

The facility also complies with the radiated and AC line conducted test site criteria set forth in CISPR 16-1, CISPR16-2.

## 1.6 Test Equipment List and Details

Table 1: Test Equipment for Emission Test and Harmonic Current / Flicker Test

Equipment	Manufacturer	Model No.	Serial No.	Last Cal	Calibration Period
Ultra-Broadband Antenna	ROHDE & SCHWARZ	HL562	100015	Nov. 20, 2020	1 year
EMI Test Receiver	ROHDE & SCHWARZ	ESI 26	100009	Nov. 20, 2020	1 year
RF Test Panel	ROHDE & SCHWARZ	TS / RSP	335015/ 0017	N/A	N/A
Turntable	ETS	2088	2149	N/A	N/A
Antenna Mast	ETS	2075	2346	N/A	N/A
EMI Test Receiver	ROHDE & SCHWARZ	ESCS30	100038	Nov. 20, 2020	1 year
Artificial Mains	ROHDE & SCHWARZ	ESH2-Z5	100028	Nov. 20, 2020	1 year
Pulse Limiter	ROHDE & SCHWARZ	ESHSZ2	100044	Nov. 20, 2020	1 year
Absorbing Clamp	ROHDE & SCHWARZ	MDS-21	100011	Nov. 20, 2020	1 year
EMI In Motion	HD	KMS 560	560/385 BJ:01	N/A	N/A
Controller	HD	HD 050	050/477 BJ:01	N/A	N/A
Purified Power Source	CALIFORNIA INSTRUMENTS	HFS500	54513	Nov. 20, 2020	1 year
Harmonic And Flicker Analyzer	EM TEST	DPA503S1	0500-10	Nov. 20, 2020	1 year



Table 2: Test Equipment for Immunity Test

Equipment	Manufacturer	Model No.	Serial No.	Last Cal	Calibration Period
ESD Simulator	EM TEST	DITOC0103Z	0301-04	Nov. 20, 2020	1 year
Signal Generator	IFR	2032	203002/100	Nov. 20, 2020	1 year
Amplifier	AR	150W1000	301584	Nov. 20, 2020	1 year
Dual Directional Coupler	AR	DC6080	301508	Nov. 20, 2020	1 year
Power Head	AR	PH2000	301193	Nov. 20, 2020	1 year
Power Meter	AR	PM2002	302799	Nov. 20, 2020	1 year
Ultra Compact Simulator	EM TEST	UCS500M6	0500-19	Nov. 20, 2020	1 year
Signal Generator	IFR	2023A	202304/060	Nov. 20, 2020	1 year
Amplifier	AR	75A250	302205	Nov. 20, 2020	1 year
Dual Directional Coupler	AR	DC2600	302389	Nov. 20, 2020	1 year
6DB Attenuator	EMTEST	ATT6/75	0010230A	Nov. 20, 2020	1 year
CDN	EMTEST	CDN M3	0802-03	Nov. 20, 2020	1 year
Ultra Compact Simulator	EM TEST	UCS500M6	0500-19	Nov. 20, 2020	1 year
Motor Driven Voltage Transformer	EM TEST	MV2616	0301-11	Nov. 20, 2020	1 year
Current Transformer	EM TEST	MC2630	D5101	Nov. 20, 2020	1 year
Magnetic Coil	EM TEST	MS100	0500-19	Nov. 20, 2020	1 year

## 2. SYSTEM TEST CONFIGURATION

### 2.1 Justification

The system was configured for testing in a typical fashion (as normally used by a typical user).

### 2.2 EUT Exercise Software

The EUT exercising program used during radiated and conducted testing was designed to exercise the various system components in a manner similar to a typical use. The software offered by manufacture, can let the EUT being normal operation.

### 2.3 Special Accessories

As shown in section 2.5, interface cable used for compliance testing is shielded as normally supplied by SDongyang Xiaoqi Industry and Trade Co., Ltd.. and its respective support equipment manufacturers.

### 2.4 Equipment Modifications

The EUT tested was not modified by HSO.

### 2.5 Configuration of Test System



### 2.6 Test Setup Diagram

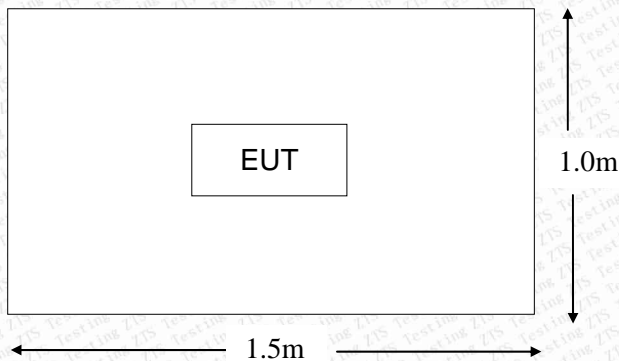

### 3. DISTURBANCE VOLTAGE AT THE MAINS TERMINALS

#### 3.1 Measurement Uncertainty

All measurements involve certain levels of uncertainties, especially in field of EMC. The factors contributing to uncertainties are spectrum analyzer, cable loss, and LISN.

The Treatment of Uncertainty in EMC Measurements, the best estimate of the uncertainty of any conducted emissions measurement is  $\pm 2.4$  dB.

#### 3.2 Limit of Disturbance Voltage At The Mains Terminals

Frequency Range (MHz)	Limits ( dBuV )	
	Quasi-Peak	Average
0.150~0.500	66~56	56~46
0.500~5.000	56	46
5.000~30.00	60	50

Note: (1) The tighter limit shall apply at the edge between two frequency bands.

#### 3.3 EUT Setup

The setup of EUT is according with CISPR 16-1, CISPR16-2 measurement procedure. The specification used was the EN 55014-1 limits.

The EUT was placed center and the back edge of the test table.

The AV cables were draped along the test table and bundled to 30-40cm in the middle.

The spacing between the peripherals was 10 cm.

Maximum emission emitted from EUT was determined by manipulating the EUT, support equipment, interconnecting cables and varying the mode of operation and the levels in the final result of the test were recorded with the EUT running in the operating mode that maximum emission was emitted.

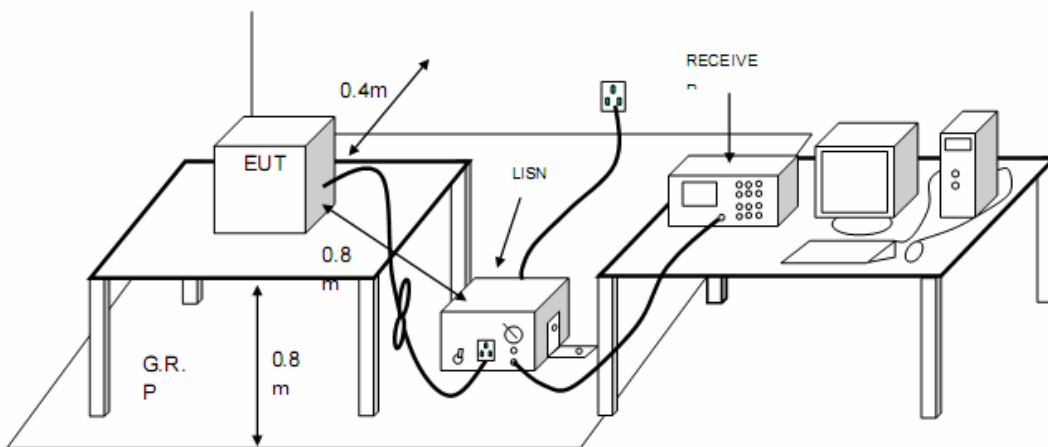

### 3.4 Instruments Setup

The test receiver was set with the following configurations:

Test Receiver Setting:

Frequency Range.....150 KHz to 30 MHz  
Detector.....Peak & Quasi-Peak & Average  
Sweep Speed.....Auto  
IF Band Width.....9 KHz

### 3.5 Test Procedure

During the conducted emission test, the EUT power cord was connected to the auxiliary outlet of the first Artificial Mains.

Maximizing procedure was performed on the six (6) highest emissions to ensure EUT compliance using all installation combination.

All data was recorded in the peak detection mode. Quasi-peak and Average readings were only performed when an emission was found to be marginal (within  $-10 \text{ dB}\mu\text{V}$  of specification limits). Quasi-peak readings are distinguished with a "QP". Average readings are distinguished with a "AV".

### 3.6 Summary of Test Results

According to the data in section 3.6, the EUT complied with the EN 55014-1 Conducted margin.

### 3.7 Disturbance Voltage Test Data

Temperature ( °C )	22~25
Humidity ( %RH )	50~55
Barometric Pressure ( mbar )	950~1000
EUT	<u>Fascia Gun</u>
M/N	7017
Operating Mode	Normal

Test data see following pages

### 3.8 Test Result

N/A

## 4. DISCONTINUOUS DISTURBANCE (CLICK)

### 4.1 Limit of Discontinuous Disturbance

The limits for discontinuous disturbance depend mainly on the character of the disturbance and on the click rate **N** as given in details in clause 4.2.2 and 4.2.3 of the standard of EN 55014-1: 2006+A1:2009.

### 4.2 EUT Setup

The setup of EUT is according with CISPR 16-1, CISPR16-2 measurement procedure. See following test setup figure. The specification used was the EN 55014-1 limits.

The spacing between the peripherals was 10 cm.

Maximum emission emitted from EUT was determined by manipulating the EUT, support equipment, interconnecting cables and varying the mode of operation and the levels in the final result of the test were recorded with the EUT running in the operating mode that maximum emission was emitted.

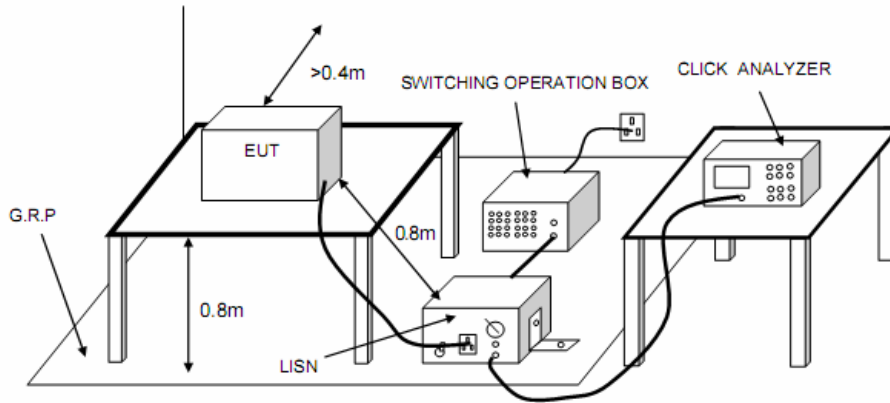

### 4.3 Test Procedure

During the Click test, the EUT power cord was connected to the auxiliary outlet of the first Artificial Mains Test Procedure details see clause 7.4.2 of standard EN 55014-1: 2006+A1:2009

### 4.4 Summary of Test Results

According to the data in section 4.3, the EUT complied with the requirement of Click test of EN 55014-1.

### 4.5 Disturbance Voltage Test Data

Temperature ( °C )	22~25
Humidity ( %RH )	50~54
Barometric Pressure ( mbar )	950~1000
EUT	N/A
M/N	N/A
Operating Mode	N/A

### 4.6 Test Result

N/A

## 5. DISTURBANCE POWER

### 5.1 Measurement Uncertainty

All measurements involve certain levels of uncertainties, especially in field of EMC. The factors contributing to uncertainties are spectrum analyzer, cable loss, and power clamp.

The Treatment of Uncertainty in EMC Measurements, the best estimate of the uncertainty of any conducted emissions measurement is  $\pm 2.4$  dB.

### 5.2 Limit of Disturbance Power

Frequency Range (MHz)	Limit (dBpW)	
	Quasi-Peak	Average
30~300	45~55	35~45

Note: (1) The limit line is a linear line.

### 5.3 EUT Setup

The setup of EUT is according with CISPR 16-1, CISPR16-2 measurement procedure. See following test setup figure. The specification used was the EN 55014-1 limits.

The EUT was placed at the edge of the test table so as to make the end of the lead close to the EUT as short as possible between the power clamp and the EUT.

The spacing between the peripherals was 10 cm.

Maximum emission emitted from EUT was determined by manipulating the EUT, support equipment, interconnecting cables and varying the mode of operation and the levels in the final result of the test were recorded with the EUT running in the operating mode that maximum emission was emitted

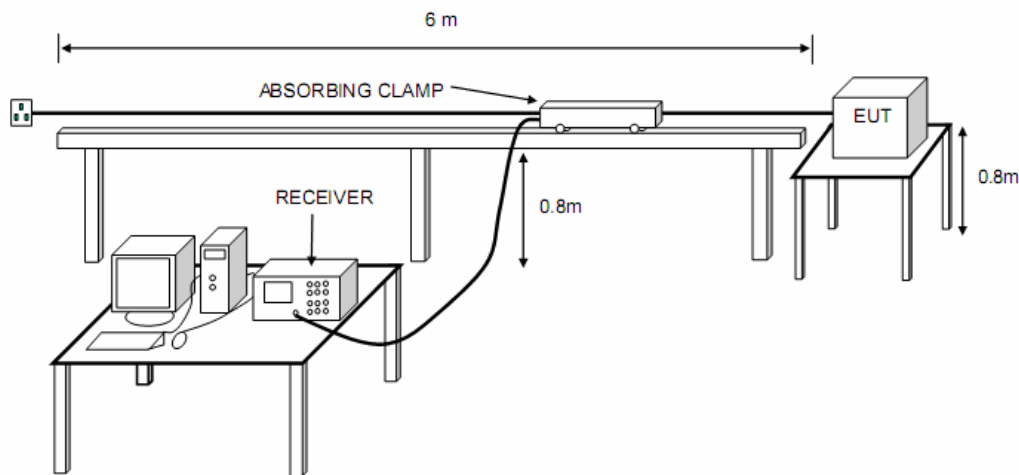

## 5.4 Instruments Setup

The test receiver was set with the following configurations:

Test Receiver Setting:

Frequency Range.....30MHz to 300 MHz  
Detector.....Peak & Quasi-Peak & Average  
Sweep Speed.....Auto  
IF Band Width.....9 KHz

## 5.5 Test Procedure

The associated equipment under test is placed on a non-metallic table of 0.8 m of height above the floor and at least 0.4 m from other objects and from any person. The lead to be measured shall be stretched in a straight horizontal line for a length sufficient to accommodate the absorbing clamp and to permit the necessary adjustment of its position for tuning. The absorbing clamp is placed around the lead to be measured, with its current transformer towards the equipment under test, so as to measure a quantity proportional to the disturbance power on the lead.

Any other lead less than that to be measured shall either be disconnected, if mechanically and functionally possible, or fitted with ferrite rings to attenuate RF currents which may affect the measurement results. Such a lead shall be stretched away from the connected unit in a direction perpendicular to the direction of the lead to be measured.

All connectors not used shall be left un-terminated. All connectors having a connected lead shall be terminated in a manner representative of use. If the leads are screened and normally terminated in a screened unit, then the termination shall be screened.

## 5.6 Disturbance Power Test Data

Temperature ( °C )	22~23
Humidity ( %RH )	50~54
Barometric Pressure ( mbar )	950~1000
EUT	Fascia Gun
M/N	7017
Operating Mode	Normal

## 5.7 Test Plot(s) for Disturbance Power

Plot(s) of Disturbance Power Test Data is presented hereinafter as reference.

## 5.8 Test Result

N/A

## 6. RADIATED EMISSION MEASUREMENT

### 6.1 Block Diagram of Test

Block diagram of test setup (In chamber)

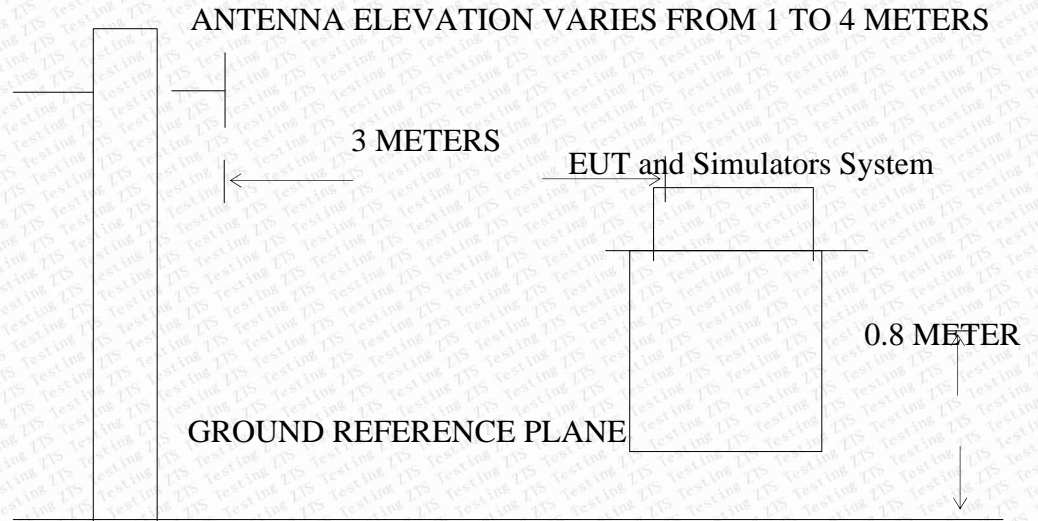

### 6.2 Measuring Standard

EN55014-1:2006+A1:2009+ A2:2011



### 6.3 Radiated Emission Limits

All emanations from a class B device or system, including any network of conductors and apparatus connected thereto, shall not exceed the level of field strengths specified below:

FREQUENCY (MHz)	DISTANCE (Meters)	FIELD STRENGTHS LIMIT (dB $\mu$ V/m)
30 ~ 230	3	40
230 ~ 1000	3	47

Note: (1) The smaller limit shall apply at the combination point between two frequency bands.

(2) Distance refers to the distance in meters between the measuring instrument antenna and the closed point of any part of the EUT.

### 6.4 EUT Configuration on Test

The EN61000-6-3 regulations test method must be used to find the maximum emission during radiated emission measurement.

### 6.5 Operating Condition of EUT

Turn on the power.

After that, let the EUT work in test mode (Normal) and measure it.

### 6.6 Test Procedure

The EUT is placed on a turn table which is 0.8 meter high above the ground. The turn table can rotate 360 degrees to determine the position of the maximum emission level. The EUT is set 3 meters away from the receiving antenna which is mounted on a antenna tower. The antenna can be moved up and down from 1 to 4 meters to find out the maximum emission level. Bilog antenna (calibrated by Dipole Antenna) is used as a receiving antenna. Both horizontal and vertical polarization of the antenna are set on test.

The bandwidth of the Receiver (ESCS30) is set at ES1kHz.  
The frequency range from 30MHz to 1000MHz is investigated.

### 6.7 Measuring Results

**PASS.**

Please reference to the following pages



Standard:	EN55014-1:2006+A1:2009+ A2:2011	Polarization:	Horizontal
Test item:	Radiation Test	Date:	2021-09-01
EUT:	Fascia Gun	Test By:	Mark
Model:	7017	Distance:	3m
Note:			

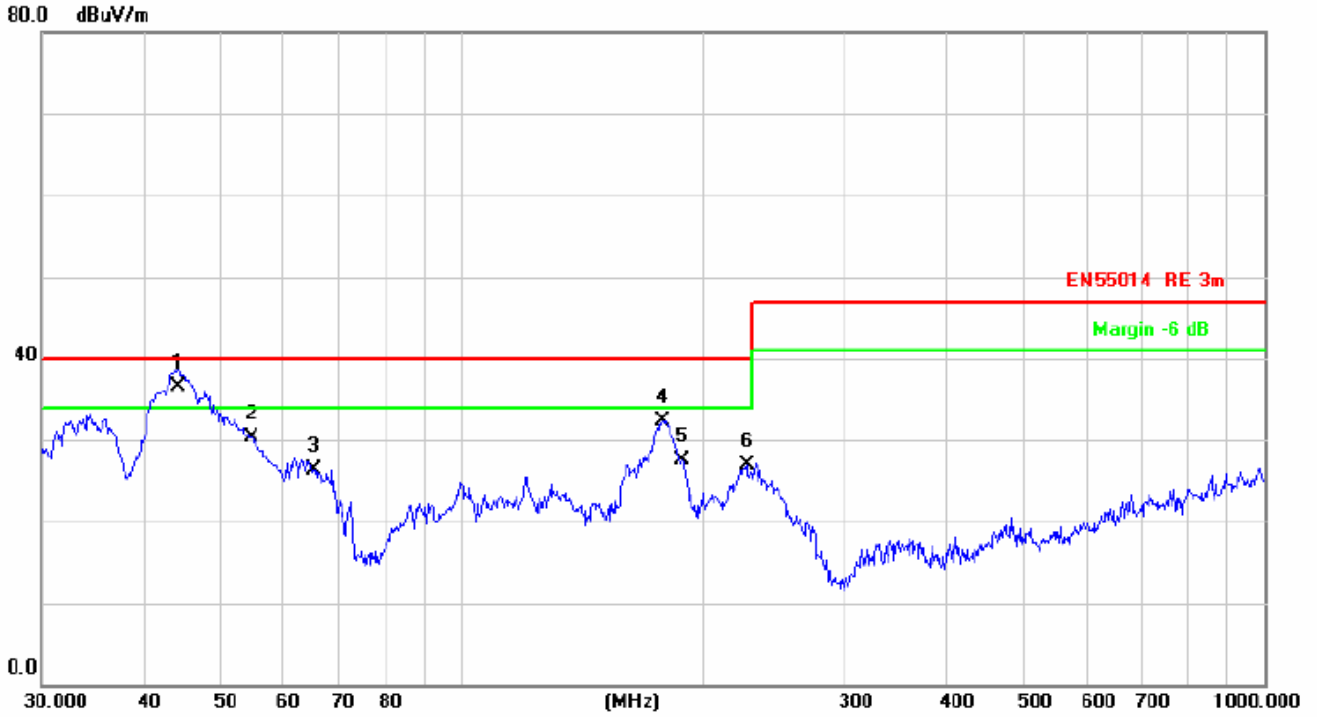

No.	Mk.	Freq.	Reading Level	Correct Factor	Measurement	Limit	Over	Antenna Height	Table Degree
		MHz	dBuV	dB/m	dBuV/m	dBuV/m	dB	cm	degree
1	*	44.2752	54.04	-17.48	36.56	40.00	-3.44	QP	
2		54.6428	50.82	-20.53	30.29	40.00	-9.71	QP	
3		65.3431	46.57	-20.25	26.32	40.00	-13.68	QP	
4		177.5089	47.97	-15.67	32.30	40.00	-7.70	QP	
5		187.7529	43.46	-15.94	27.52	40.00	-12.48	QP	
6		226.0994	42.52	-15.70	26.82	40.00	-13.18	QP	



Standard:	EN55014-1:2006+A1:2009+ A2:2011	Polarization:	Horizontal
Test item:	Radiation Test	Date:	2021-09-01
EUT:	Fascia Gun	Test By:	Mark
Model:	7017	Distance:	3m
Note:			



No.	Mk.	Freq. MHz	Reading Level dBuV	Correct Factor dB/m	Measurement dBuV/m	Limit dBuV/m	Over dB	Antenna Height cm	Table Degree degree	Comment
1		70.5836	49.27	-19.92	29.35	40.00	-10.65	QP		
2		127.6645	44.30	-14.00	30.30	40.00	-9.70	QP		
3		137.9028	44.00	-14.63	29.37	40.00	-10.63	QP		
4		158.1123	46.09	-14.73	31.36	40.00	-8.64	QP		
5		182.5592	46.25	-16.03	30.22	40.00	-9.78	QP		
6	*	228.4902	49.13	-15.40	33.73	40.00	-6.27	QP		

## 7. ELECTROSTATIC DISCHARGE IMMUNITY TEST (EN 61000-4-2)

### 7.1 Block Diagram of Test Setup

#### 9.1.1 Block diagram of connection between the EUT and Load

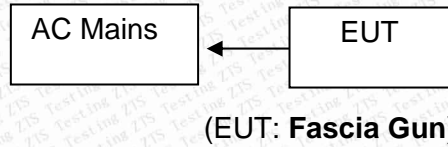

#### 7.1.2 Block diagram of ESD test setup

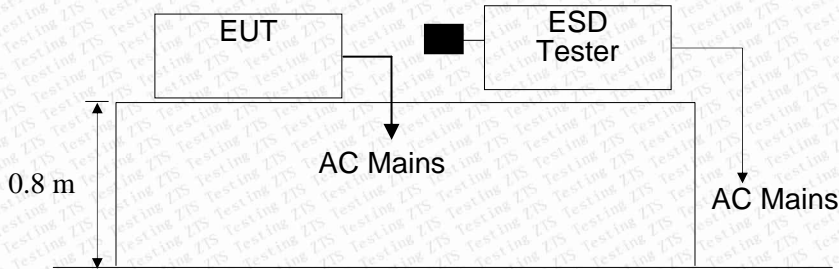

### 7.2 Test Standard

EN 55014-2: 2015 , (EN61000-4-2: 2009 Severity Level: 3 / Air Discharge: ±8KV Level: 2 / Contact Discharge: ±4KV)

### 7.3 Severity Levels and Performance Criterion

#### 7.3.1 Severity level

Level	Test Voltage Contact Discharge (KV)	Test Voltage Air Discharge (KV)
1	±2	±2
2	±4	±4
3	±6	±8
4	±8	±15
X	Special	Special

#### 7.3.2 Performance criterion: B

### 7.4 Operating Condition of EUT

7.4.1 Setup the EUT as shown on Section 8.1.

7.4.2 Turn on the power of all equipments.

7.4.3 Let the EUT work in measuring mode (Normal) and measure it.

## 7.5 Test Procedure

### 7.5.1 Air Discharge:

This test is done on a non-conductive surface. The round discharge tip of the discharge electrode shall be approached as fast as possible to touch the EUT. After each discharge, the discharge electrode shall be removed from the EUT. The generator is then re-triggered for a new single discharge and repeated 10 times for each pre-selected test point. This procedure shall be repeated until all the air discharge completed.

### 7.5.2 Contact Discharge:

All the procedure shall be same as Section 8.5.1. Except that the tip of the discharge electrode shall touch the EUT before the discharge switch is operated.

### 7.5.3 Indirect discharge for horizontal coupling plane

At least 10 single discharges (in the most sensitive polarity) shall be applied at the front edge of each HCP opposite the center point of each unit (if applicable) of the EUT and 0.1m from the front of the EUT. The long axis of the discharge electrode shall be in the plane of the HCP and perpendicular to its front edge during the discharge.

### 7.5.4 Indirect discharge for vertical coupling plane

At least 10 single discharge (in the most sensitive polarity) shall be applied to the center of one vertical edge of the coupling plane. The coupling plane, of dimensions 0.5m X 0.5m, is placed parallel to, and positioned at a distance of 0.1m from the EUT. Discharges shall be applied to the coupling plane, with this plane in sufficient different positions that the four faces of the EUT are completely illuminated.

## 7.6 Test Results

N/A

## 8.0 RF FIELD STRENGTH SUSCEPTIBILITY TEST

### 8.1 Block Diagram of Test

#### 8.1.1 Block diagram of connection between the EUT and Load



#### 8.1.2 Block diagram of RS test setup

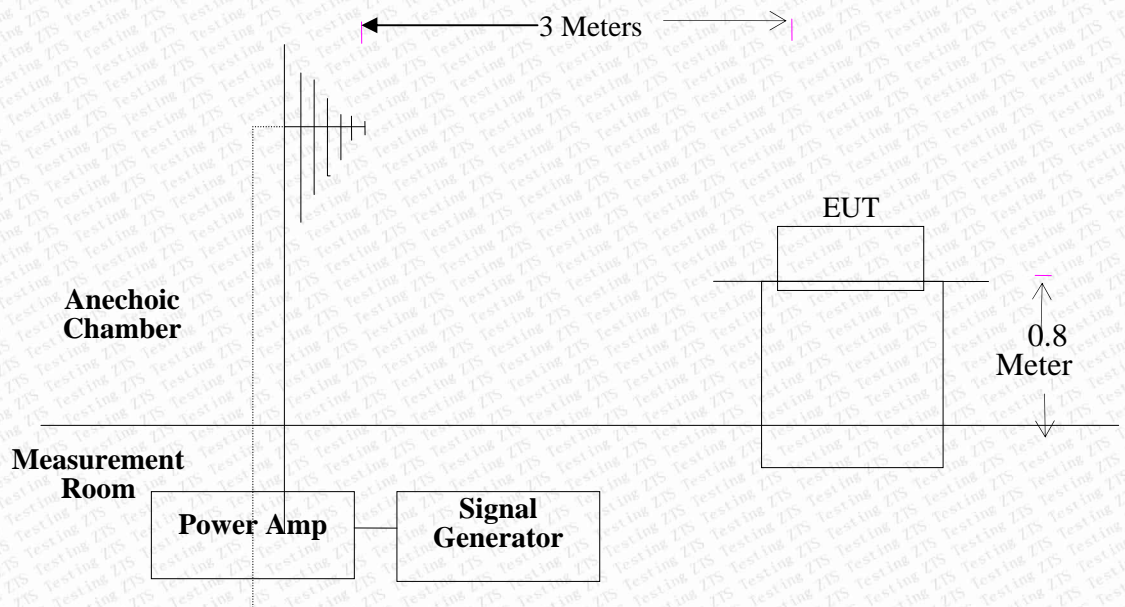

### 8.2 Test Standard

EN 55014-2: 2015

(EN61000-4-3:2006 +A1:2008+A2:2010 (Severity Level: 2, 25.2V / m))

### 8.3 Severity Levels and Performance Criterion

#### 8.3.1 Severity Levels

Level	Field Strength V/m
1.	1
2.	3
3.	10
X	Special

#### 8.3.2 Performance Criterion : A

### 8.4 EUT Configuration on Test

The configuration of the EUT is same as Section 3.3.

### 8.5 Operating Condition of EUT

Same as radiated emission measurement which is listed in Section 3.4, except the test setup replaced as Section 8.1.

### 8.6 Test Procedure

The EUT are placed on a table which is 0.8 meter high above the ground. The EUT is set 3 meters away from the transmitting antenna which is mounted on an antenna tower. Both horizontal and vertical polarization of the antenna are set on test. Each of the four sides of the EUT must be faced this transmitting antenna and measured individually. In order to judge the EUT performance, a CCD camera is used to monitor its screen. All the scanning conditions are as following:

Condition of Test	Remark
1. Fielded Strength	25.2V/m (Severity Level 2)
2. Radiated Signal	Modulated
3. Scanning Frequency	80-1000MHZ
4. Sweep time of radiated	0.0015 Decade/s
5. Dwell Time	1 Sec.

### 8.7 Test Results

N/A

## 9. ELECTRICAL FAST TRANSIENT/BURST IMMUNITY TEST (EN 61000-4-4)

### 9.1 Block Diagram of Test Setup

#### 9.1.1. Block Diagram of the EUT

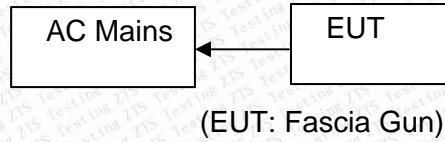

#### 9.1.2. Block Diagram of the AC Mains

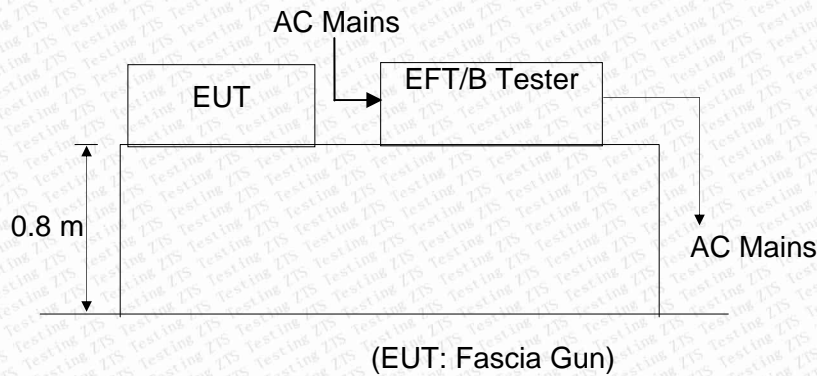

### 9.2 Test Standard

EN 55014-2: 2015 , (EN61000-4-4: 2004+A1: 2010, Severity Level, Level 2: 1KV)

### 9.3 Severity Levels and Performance Criterion

#### 9.3.1 Severity level

Level	Open Circuit Output Test Voltage $\pm 10\%$	
	On Fascia Gun Lines	On I/O (Input/Output) Signal data and control lines
1	0.5 KV	0.25 KV
2	1 KV	0.5 KV
3	2 KV	1 KV
4	4 KV	2 KV
X	Special	Special

#### 9.3.2 Performance criterion: B

### 9.4 Operating Condition of EUT

9.4.1 Setup the EUT as shown in Section 9.1.

9.4.2 Turn on the power of all equipments.

9.4.3 Let the EUT work in test mode (Normal) and measure it.



### 9.5 Test Procedure

The EUT is put on the table which is 0.8 meter high above the ground. This reference ground plane shall project beyond the EUT by at least 0.1m on all sides and the minimum distance between EUT and all other conductive structure, except the ground plane beneath the EUT, shall be more than 0.5m.

9.5.1 For input and output AC power ports:  
It's unnecessary to test

9.5.2 For signal lines and control lines ports:  
It's unnecessary to test.

9.5.3 For DC Input line ports:

The EUT is connected to the DC power mains by using a coupling device which couples the EFT interference signal to DC power lines. Both polarities of the test voltage should be applied during compliance test and the duration of the test is 2 mins.

### 9.6 Test Result

PASS

Temperature ( °C )	22~23
Humidity ( %RH )	50~54
Barometric Pressure ( mbar )	950~1000
EUT	Fascia Gun
M/N	7017
Operating Mode	Normal

EN 61000-4-4 Test Points		Test Levels (kV)							
		+0.5	-0.5	+1.0	-1.0	+2.0	-2.0	+4.0	-4.0
Power Supply Power Line of EUT	L1	A	A	A	A	/	/	/	/
	N	A	A	A	A	/	/	/	/
	Earth	/	/	/	/	/	/	/	/
	L1+N	A	A	A	A	/	/	/	/
	L1 + Earth	/	/	/	/	/	/	/	/
	N+ Earth	/	/	/	/	/	/	/	/
	L1+N+Earth	/	/	/	/	/	/	/	/

## 10. SURGE IMMUNITY TEST (EN 61000-4-5)

### 10.1 Block Diagram of Test Setup

#### 10.1.1. Block Diagram of the EUT

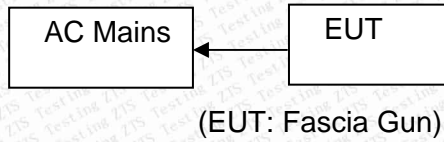

#### 10.1.2. Block Diagram of the AC Mains

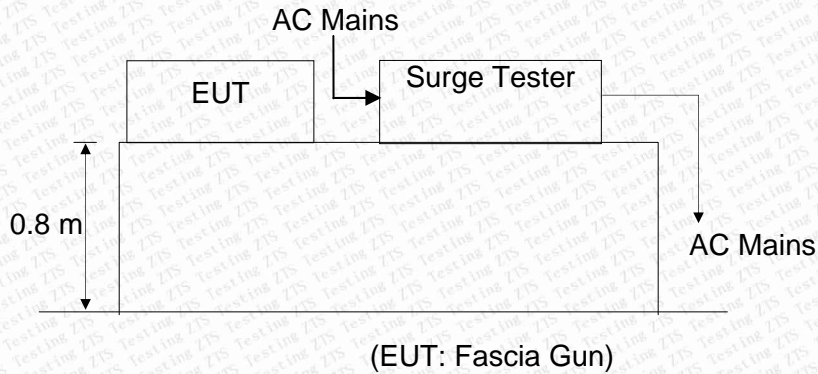

### 10.2 Test Standard

EN 55014-2: 2015 , (EN61000-4-5: 2006 Severity Level: Line to Line, Level 2: 1KV, Line to Earth , Level 3: 2KV)

### 10.3 Severity Levels and Performance Criterion

#### 10.3.1. Severity level

Severity Level	Open-Circuit Test Voltage KV
1	0.5
2	1.0
3	2.0
4	4.0
*	Special

#### 10.3.2 Performance criterion: B

### 10.4 Operating Condition of EUT

10.4.1 Setup the EUT as shown in Section 10 .1.

10.4.2. Turn on the power of all equipments.

10.4.3. Let the EUT work in test mode (Normal) and measure it.

## 10.5 Test Procedure

- 1) Set up the EUT and test generator as shown on Section 10.1.2.
- 2) For DC port coupling mode, provide a 1 KV 1.2/50us voltage surge (at open-circuit condition) and 8/20us current surge to EUT selected points.
- 3) At least 5 positive and 5 negative (polarity) tests with a maximum 1/min repetition rate are conducted during test.
- 4) Record the EUT operating situation during compliance test and decide the EUT immunity criterion for above each test.

## 10.6 Test Result

N/A

## 11. CONDUCTED SUSCEPTIBILITY TEST (EN 61000-4-6)

### 11.1 Block Diagram of Test Setup

#### 11.1.1. Block Diagram of the EUT

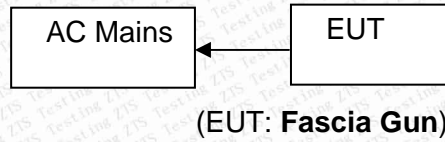

#### 11.1.2. Block Diagram of the AC Mains

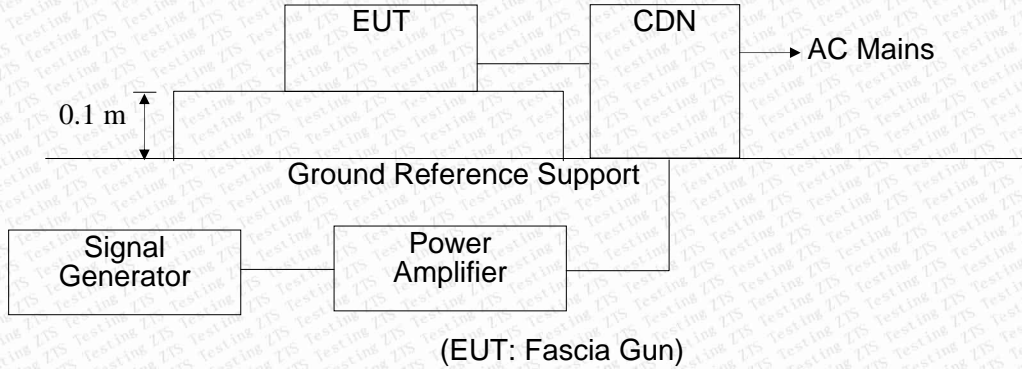

### 11.2 Test Standard

EN 55014-2: 2015 (EN61000-4-6: 2009, Severity Level 2: 25.2V(rms)).  
(0.15MHz ~ 230MHz)

### 11.3 Severity Levels and Performance Criterion

#### 11.3.1. Severity level

Level	Field Strength V(r.m.s)
1	1
2	3
3	10
X	Special

#### 11.3.2 Performance criterion: A

### 11.4 Operating Condition of EUT

11.4.1 Setup the EUT as shown in Section 11 .1.

11.4.2 Turn on the power of all equipments.

11.4.3 Let the EUT work in test mode (Normal) and measure it.

## 11.5 Test Procedure

### 11.5.1 For AC Mains

It's unnecessary to test.

### 11.5.2 For signal lines and control lines ports:

It's unnecessary to test.

### 11.5.3 For DC Input line ports:

- 1) Set up the EUT, CDN and test generators as shown on Section 11 .1.
- 2) Let the EUT work in test mode and measure it.
- 3) The EUT are placed on an insulating support 0.1m high above a ground reference plane. CDN (coupling and decoupling network) is placed on the ground plane about 0.3m from EUT. Cables between CDN and EUT are as short as possible, and their height above the ground reference plane shall be between 30 and 50 mm (where possible).
- 4) The disturbance signal described below is injected to EUT through CDN.
- 5) The EUT operates within its operational mode(s) under intended climatic conditions after power on.
- 6) The frequency range is swept from 150KHz to 230MHz using 25.2V signal level, and with the disturbance signal 80% amplitude modulated with a 1KHz sine wave.
- 7) The rate of sweep shall not exceed  $1.5 \times 10^{-3}$  decades/s. Where the frequency is swept incrementally, the step size shall not exceed 1% of the start and thereafter 1% of the preceding frequency value.

Recording the EUT operating situation during compliance testing and decide the EUT immunity criterion.

## 11.6 Test Results

N/A

## 12. VOLTAGE DIPS, SHORT INTERRUPTIONS IMMUNITY TESTS (EN61000-4-11)

### 12.1 Block Diagram of Test Setup

#### 12.1.1. Block Diagram of the EUT

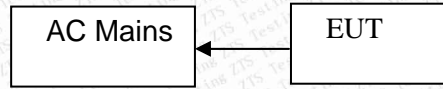

(EUT: Fascia Gun)

#### 12.1.2. Block Diagram of the AC Mains

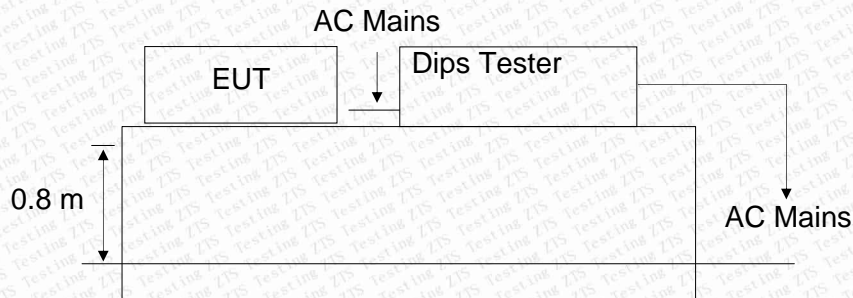

(EUT: Fascia Gun)

### 12.2 Test Standard

EN 55014-2: 2015 (EN61000-4-11: 2004)

### 12.3 Severity Levels and Performance Criterion

Test Level %UT	Voltage dip and short interruptions %UT	Duration (in period)
0	100	0.5 1 5
40	60	10 25
70	30	50 *

Performance criterion: B&C

### 12.4 EUT Configuration

The configuration of EUT is listed in Section 12.4.

### 12.5 Operating Condition of EUT

12.5.1 Turn on the power of all equipments.

12.5.2 Let the EUT work in test mode (Normal) and measure it.

## 12.6 Test Procedure

- 1) Set up the EUT and test generator as shown on Section 12.1.2.
- 2) The interruption is introduced at selected phase angles with specified duration.
- 3) Record any degradation of performance.

## 12.7 Test Result

N/A

## 13. TEST RESULTS

---

The following tests were performed on the SDongyang Xiaoqi Industry and Trade Co., Ltd.'s product; model: 7017; the actual test results are contained within the Test Data section of this report.

### 13.1 EN 61000-4-2 Electrostatic Discharge Immunity Test Configuration

The EUT was subjected to the electrostatic discharge tests required by EN 55014-2 and all lower levels specified in EN 61000-4-2.

*The EUT continued to perform as intended during and after the application of the ESD. Test setup pNormalographs presented in Appendix C.*

### 13.2 EN 61000-4-3 Electrostatic Discharge Immunity Test Configuration

The EUT was subjected to the electrostatic discharge tests required by EN 55014-2 and all lower levels specified in EN 61000-4-3.

*The EUT continued to perform as intended during and after the application of the ESD. Test setup pNormalographs presented in Appendix C.*

### 13.3 EN 61000-4-4 Electrical Fast Transient/Burst Immunity Test Configuration

The EUT was subjected to the electrical fast transient tests required by EN 55014-2 and all lower levels specified in EN 61000-4-4.

*The EUT continued to perform as intended during and after the application of the EFT/B. Test setup pNormalographs presented in Appendix C.*

### 13.4 EN 61000-4-5 Surge Immunity Test Configuration

The EUT was subjected to the Surge Immunity tests required by EN 55014-2 and all lower levels specified in EN 61000-4-5.

*The EUT continued to perform as intended during and after the application of the Surge Immunity Test.*

### 13.5 EN 61000-4-6 Conducted Susceptibility Test Configuration

The EUT was subjected to the Conducted Susceptibility tests required by EN 55014-2 and all lower levels specified in EN 61000-4-6.

*The EUT continued to perform as intended during and after the application of the Conducted Susceptibility Test.*

### 13.6 EN 61000-4-11 Voltage Dips, Short Interruptions Immunity Tests Configuration

The EUT was subjected to the Voltage Dips/Interruptions tests required by EN 55014-2 and all lower levels specified in EN 61000-4-11.

*The EUT continued to perform as intended during and after the application of the Voltage Dips/Interruptions Test.*



## Appendix A - Product Labeling

---

### CE Mark Label Specification

Specification: Text is Black or white in color and is left justified. Labels are printed in indelible ink on permanent adhesive backing and shall be affixed at a conspicuous location on the EUT or Silk-screened onto the EUT.



## Appendix B- EUT PHOTOGRAPHS



Photo 1



Photo 2



Photo 3



Photo 4



Photo 5

\*\*\*\*\*END OF THE REPORT\*\*\*\*\*