



## Quick Start Guide



## SMART HOME ALARM SYSTEM

AS800011

Home is not a place, it's a feeling

EN

## Package Content

1 x Gateway



1 x Voice Siren

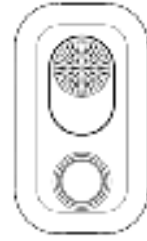

1 x IP Camera\*



1 x PIR Motion Detector

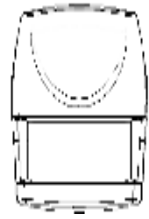

1 x Magnetic Contact Detector



1 x Remote Control



\*Optional item

## Gateway Installation

1. Choose a suitable location for the Gateway, e.g. living room.
2. Connect internet cable from your router to one of the ports on the Gateway, as shown below.
3. Plug the DC adaptor to the Gateway to power it on.

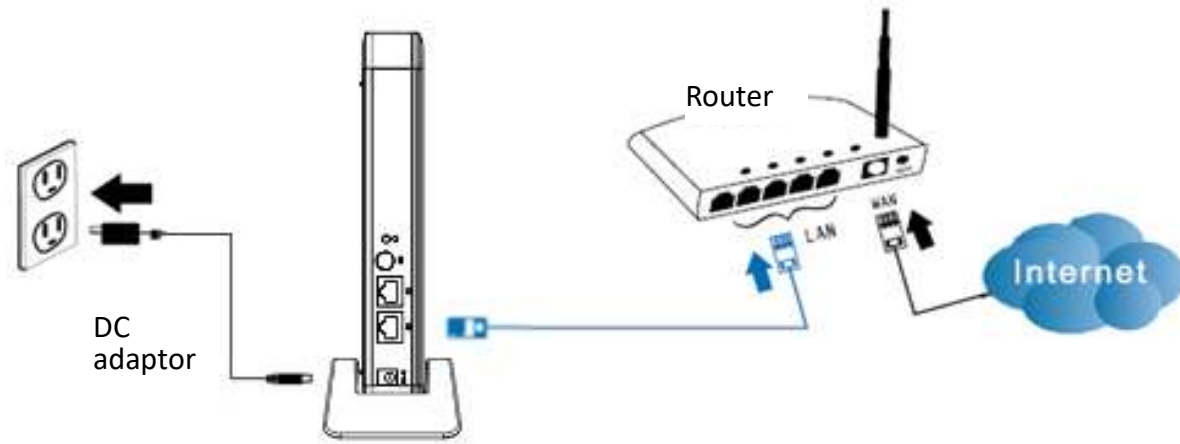

4. Wait until the Internet LED on the gateway turns green (this may take some time).

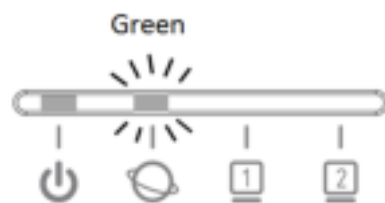

## Register the Gateway via PC

Create a new account at [www.elro-smartalarm.com](http://www.elro-smartalarm.com)

1. Click on "Create a new account"



Create a new account

2. Enter the required information and click "Submit".

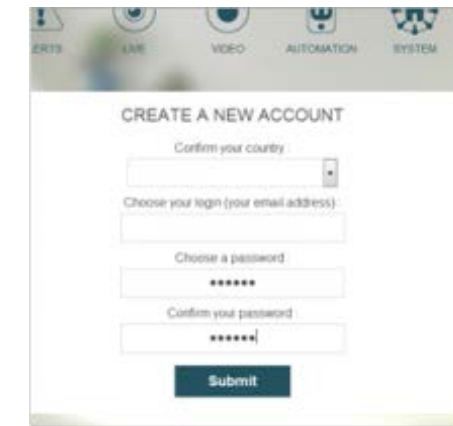

3. Enter the Access code. It is printed on the label at the back of the Gateway. Click "Next step" when finished.



Access code label

5. The system will now test if the gateway is connected to the server.

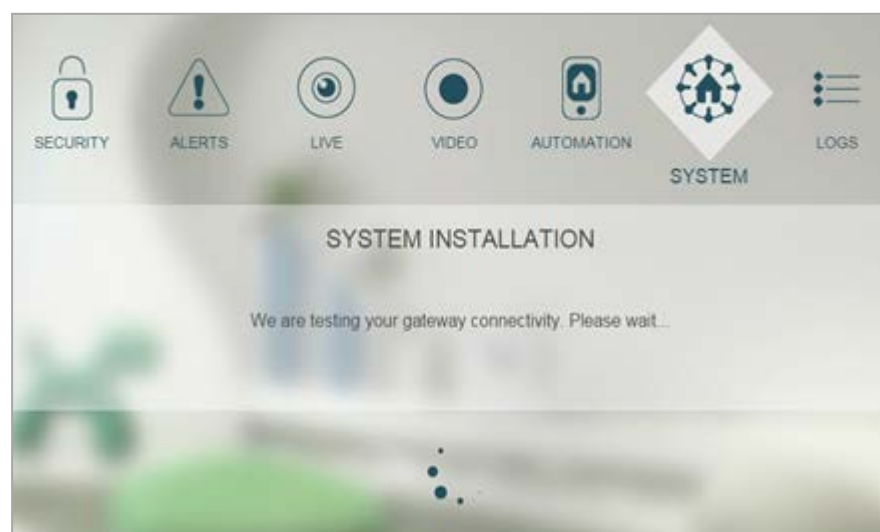

6. The system may upgrade the Gateway software, **do not unplug the power or internet connection** during the upgrade.

7. Click “Terminate” when the test is complete. The Gateway is now ready for use.

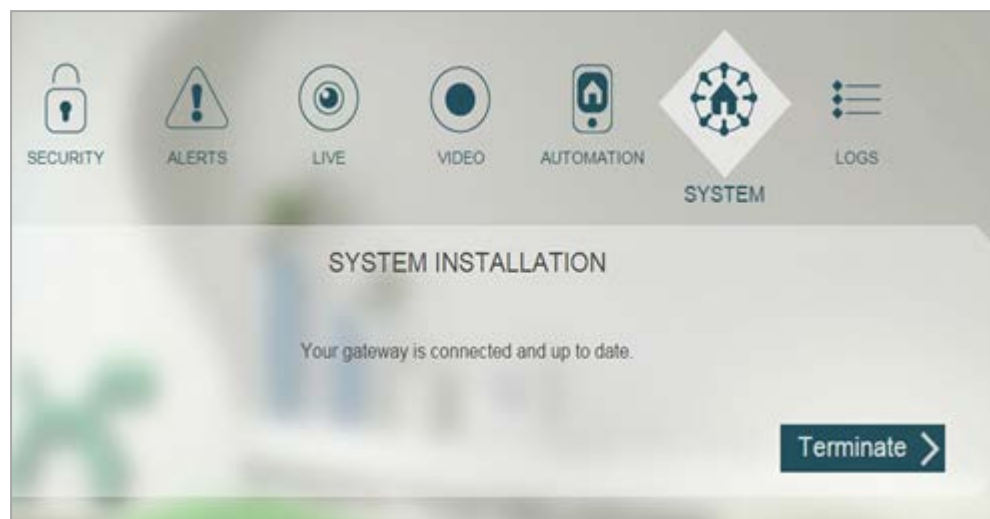

## Download the APP to your smartphone (via Google Play or APP store)

Search for ELRO Smart Home Alarm APP:

For IOS



For Android



1. Install the App into your smartphone.
2. Login into the App using the account you created earlier.

## Device Installation

1. Insert the batteries into the devices.

Note: The devices are already pre-linked (paired) to gateway at factory.

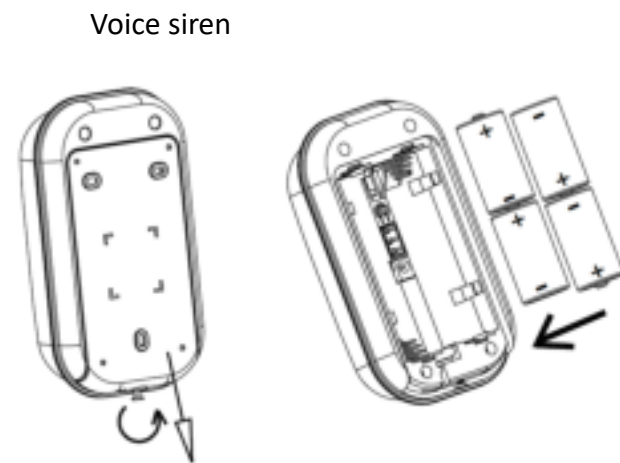
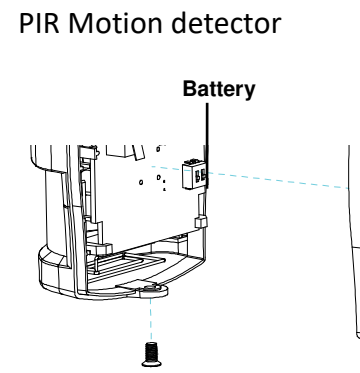
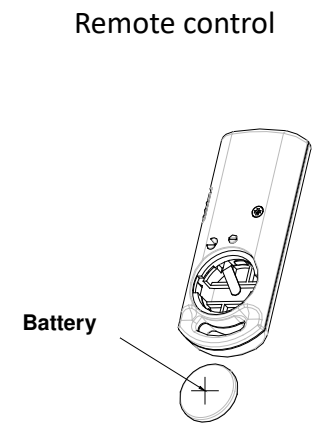

Magnetic contact detector  
(if battery is included)

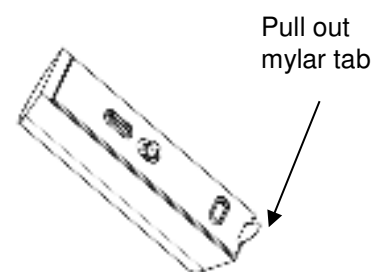

Magnetic contact detector  
(if battery is not included)

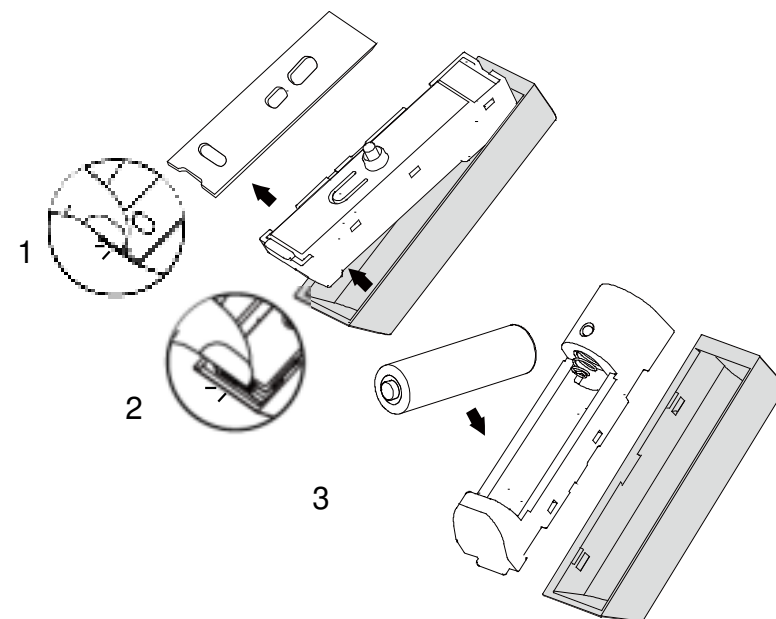

2. Select the location to mount the devices.

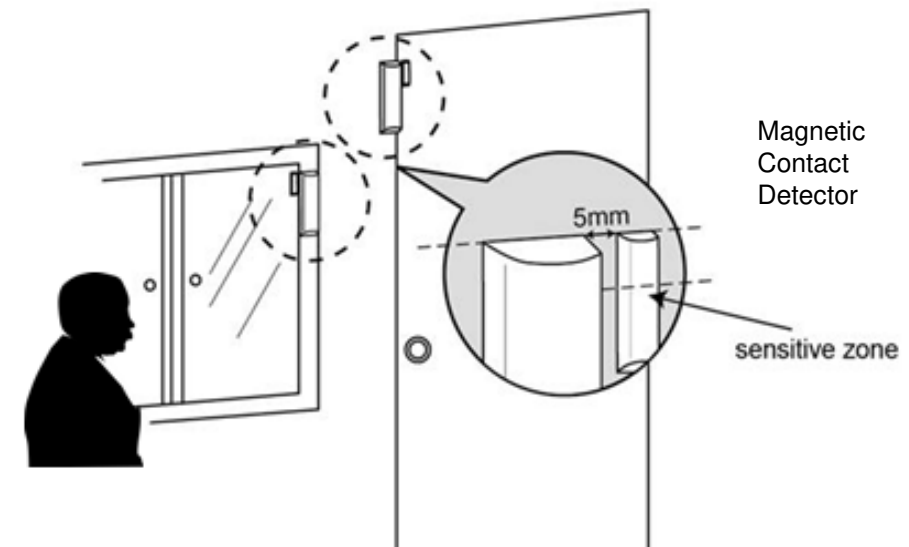
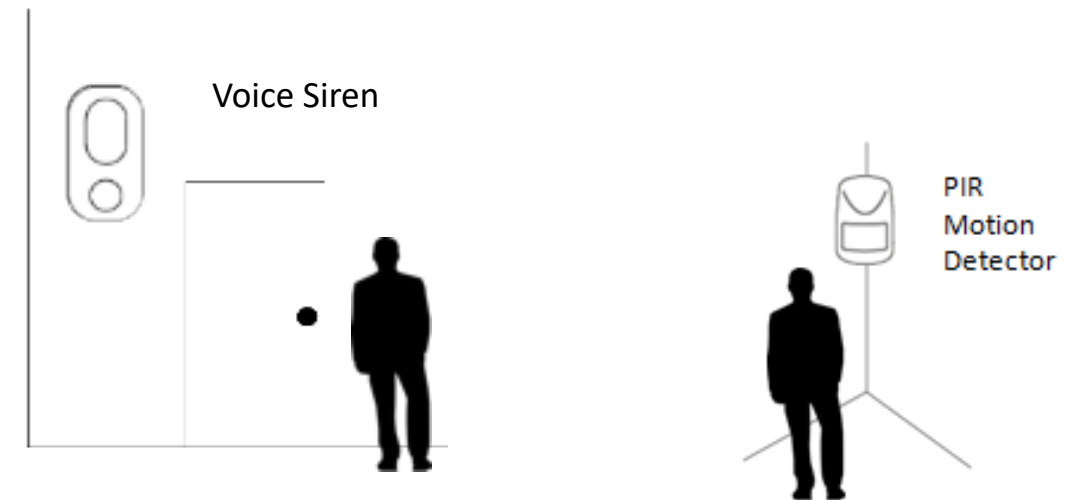

## Install the camera\*

### Connecting camera to home Wi-Fi

1. On the ELRO Smart Home Alarm APP, go to System page and tap the QR code icon on the top bar.



2. Enter your home Wi-Fi network and your Wi-Fi password, if any.
3. The App will then generate a large size QR code image. Leave the App on that page.
4. Power up the camera and wait for a musical tone (about 30 secs).



The musical tone indicates the camera is ready to scan the QR code created earlier by the App.

5. Place the QR code at about 10cm in front of the camera lens.

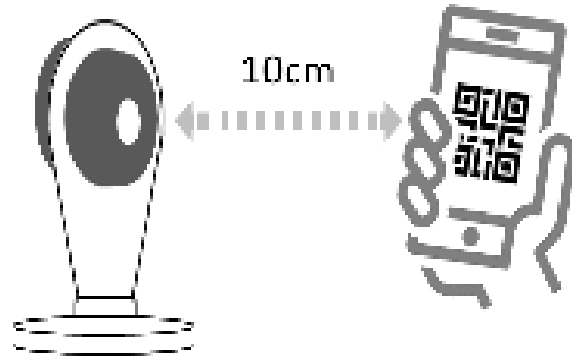

6. If the QR scan is successful, a musical tone will be heard. The camera will then attempt to connect to the home network.

**Note :** If there is no musical tone after 30 seconds, try moving the smartphone further away from the camera in gradual steps.

### Binding with ELRO Smart Home Alarm

1. Log into the [www.elro-smartalarm.com](http://www.elro-smartalarm.com) from a web browser.
2. Under "System", click on "Add a device" and select "Camera".



3. Enter the Access Code on the label behind the camera and click "Next step".

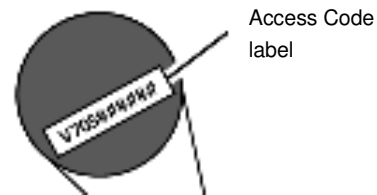

*\*If camera is included in package*

### Testing the devices

1. Firstly, close the window/door fixed with the magnetic contact detector.

### Testing remote control, Voice Siren:

2. Use the remote to arm the system. You should hear the voice siren talking.

### Testing Magnetic Door contact, Solar Siren, App notification message

3. Wait for 30 secs then open the window.
4. The installation is successful if the voice siren issues a warning and then starts to sound within 30 secs.
5. Use the remote control to quickly disarm the system. The siren should stop immediately.
6. Check your smart phone or tablet. It should receive notifications from the ELRO Smart Home Alarm APP.

### Testing PIR Motion detector

7. Use the remote to arm the system again.
8. Walk past the PIR.
9. The installation is successful if the siren issues a warning and then starts to sound within 30 secs. Use your mobile to disarm the system.

### Testing Camera\*

10. Use the ELRO Smart Home Alarm APP and choose "Live", select the camera, and the image can be seen.  
*\*If camera is included in package*

### Troubleshooting

1. Minimum distance  
Please keep all accessories at least 30cm away from each other.
2. Metal objects  
Please keep accessories away from nearby metal objects as these may interfere with the radio signals.
3. Environments with high concentration of radio signals  
Environments with high concentration of electricity and wireless signals may interfere and limit the maximum distance of accessories from the gateway.
4. Internet connection problem  
The gateway will periodically check internet connections. Try restarting the gateway if a problem occurs. The gateway uses DHCP to get its IP.
5. Battery status  
Check the battery level of the devices if they are not responding properly. If the LED on the PIR and magnetic contact detector blinks when they are activated, this means battery is low.
6. Pairing  
When the device is triggered but there is no response, a possible reason could be that the pairing during factory setting has failed. Refer to the user manual for each device to perform manual pairing.
7. Camera fail to connect to home network  
If the web page indicates camera is not reachable, it could be the Wi-Fi information in the QR code set up might be incorrect. Reset the camera and try again. To reset, use a sharp object (e.g. pin) to press the reset button behind the camera for more than 10 secs and release. Then repeat the entire steps in the section **Connecting Camera to home Wi-Fi** again.
8. More information about devices  
Refer to the user manual for each device.



**WARNING:**

Do not dispose of electrical appliances as unsorted municipal waste, use separate collection facilities. Contact your local government for information regarding the collection systems available.

If electrical appliances are disposed of in landfills or dumps, hazardous substances can leak into the groundwater and get into the food chain, damaging your health and well-being.

When replacing old appliances with new ones, the retailer is legally obligated to take back your old appliance for disposal free of charge.

**CAUTION:**

RISK OF EXPLOSION IF BATTERY IS REPLACED BY AN INCORRECT TYPE. DISPOSE OF USED BATTERIES ACCORDING TO THE INSTRUCTIONS

**Federal Communication Commission Interference Statement**

This equipment has been tested and found to comply with the limits for a Class B digital device, pursuant to Part 15 of the FCC Rules. These limits are designed to provide reasonable protection against harmful interference in a residential installation. This equipment generates, uses and can radiate radio frequency energy and, if not installed and used in accordance with the instructions, may cause harmful interference to radio communications. However, there is no guarantee that interference will not occur in a particular installation. If this equipment does cause harmful interference to radio or television reception, which can be determined by turning the equipment off and on, the user is encouraged to try to correct the interference by one of the following measures:

- Reorient or relocate the receiving antenna.
- Increase the separation between the equipment and receiver.
- Connect the equipment into an outlet on a circuit different from that to which the receiver is connected.
- Consult the dealer or an experienced radio/TV technician for help.

This device complies with Part 15 of the FCC Rules. Operation is subject to the following two conditions: (1) This device may not cause harmful interference, and (2) this device must accept any interference received, including interference that may cause undesired operation.

FCC Caution: Any changes or modifications not expressly approved by the party responsible for compliance could void the user's authority to operate this equipment.

This transmitter must not be co-located or operating in conjunction with any other antenna or transmitter.



ELRO Europe Postbus 9607 - Box E80D 1006 GC Amsterdam The Netherlands	 GUARANTEE www.elro.eu	V1 Symbols: Recycling and disposal: The WEEE symbol means that this product and batteries must be disposed separately from other household waste. When it reaches its end of life, take it to a designated waste collection point in your area to guarantee a safe disposal or recycling. Protect the environment, human health and natural resources!
--	---	---