

Magic

Set Up:

Remove the tricks and open the magic box as in figure 1, with the openings facing you. The box that the tricks are stored in doubles as your magicians stage and table to conceal the set-up of tricks.

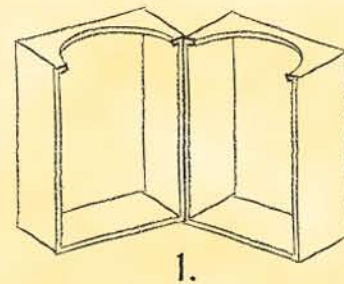

The Great Escape

Trick: Make a box magically disappear after it is put inside another in plain view.

How it's Done: Remove the flat piece with the hole cut in it and remove the inner cube which is actually two pieces (1). Be sure to hold it tightly so you don't reveal that it is two pieces. Show the audience the cube to give the impression it is one piece. Hold the cube and apply pressure to the corners indicated (2). This will keep the pieces together and set you up for the next step. Place the cube BEHIND the magic box to hide it from the audience, and release the pressure on the corners (3). The inner cube will slide out. Show the audience the outer cube still in your hand making sure that the observers cannot see the two open sides, place it in the box with the cut-outs in the orientation shown, and replace the top (4). Now turn the side of the box with the cut-outs toward the observers, and it will look as if the cube has disappeared before their eyes!

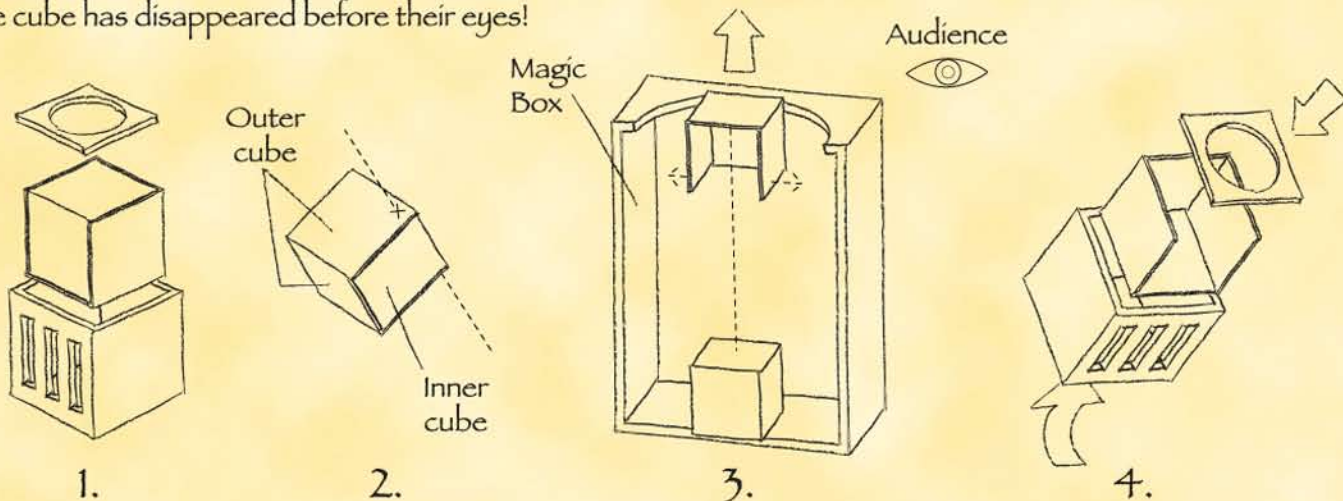
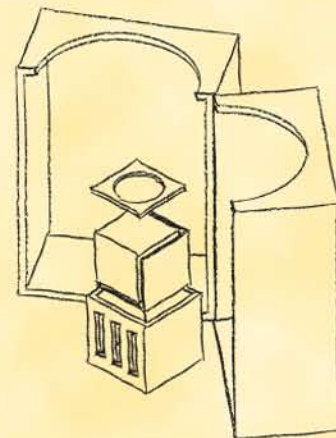

Magic Number Prediction

Trick: Mysteriously pick the number chosen by an audience member.

How it's Done: Ask someone to choose a number from one of the six cards and have them tell you which card or cards that number is on. Add the numbers in the top left corners of the cards selected to get the answer.

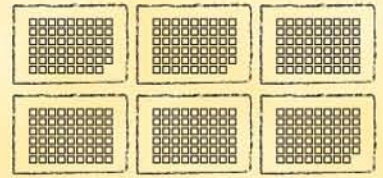

Disappearing Ball

Trick: Make a ball vanish with a wave of your hand.

How It's Done: This trick relies on a secret panel in the box, which is connected to the lid. When your hand slides the lid across the box, the panel also slides and hides the ball against the side of the box. Begin the trick with the box in one hand. Place the ball into the box with the other hand. Make sure the audience sees that the ball is in the box. Place your free hand on the lid, and slide the lid until the box is closed. Remove your hand from the lid, but keep the box closed by gently holding the edges of the lid with the fingers of your other hand. Announce that the ball in the box will magically disappear. Wave your free hand clockwise, above the box, then smoothly open the box by sliding the lid clockwise. (Don't push the lid too far!) The box will open and the ball will be gone!

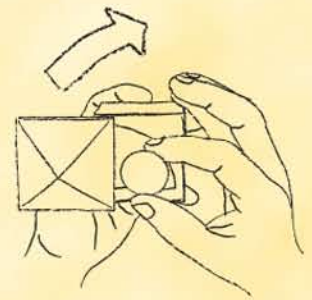

Vanishing Coin

Trick: Make a coin move and disappear.

How it's Done: Borrow a coin from an audience member. Place the coin in the box on top of the raised shelf and then close the door. Tell them you will now make the coin disappear. Tilt the box so the coin slides to the opposite side under the other door. The audience member will see the coin move through the gap in the middle. Open up the door on the side you started on and say "see, the coin is gone". Since the observer saw the coin move they will insist it is just on the other side. Give in and open the other door and show them they are right. Now say you will try again. Close both doors and tilt the box back the other way. To the observer, it will just look like the coin slid back same as before. Insist that now the coin has disappeared. Open up the door and show that the coin is gone. Since they saw the coin move through the gap same as before, they will insist that it is just back on the other side again. Open up both sides and show them that the coin is really gone!

*Note: Keep the side with the raised shelf (the side you start on) always angled out slightly toward the observer. This helps hide the shelf that the coin slides under.

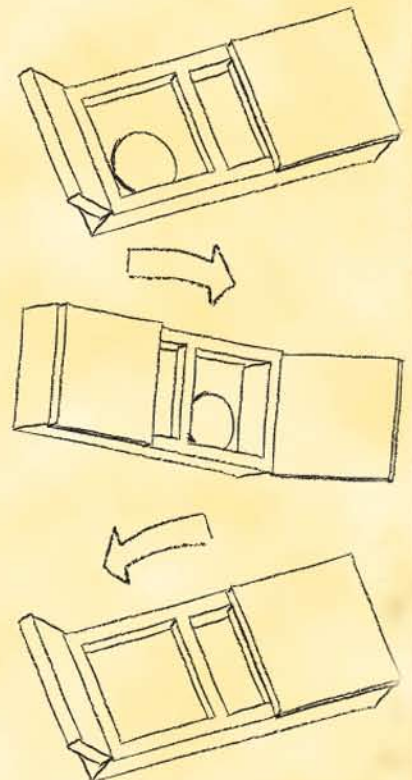

Cylinder Squeeze

Trick: Mysteriously push a red cylinder through blue and green ones.

How it's Done: The secret here is that there are two red cylinders which are slightly larger than the blue and green ones. They will not pass all the way through the box. Begin the trick by already having a red cylinder in one end. Put your finger over the hole so it doesn't fall out. (Be sure to hold the trick carefully so you cannot hear or see the red cylinder that is already inside.) The remaining cylinders are in plain view for the audience. With your finger still keeping the red cylinder in, show the audience quickly that the box is empty. (The red cylinder inside will look like your finger.) Now hold the box diagonally and gently add the blue and green cylinders. Make sure the audience pays attention to the order you add them. Add the remaining red cylinder. Put a finger on the top, give a quick shake and carefully remove the bottom finger and let the cylinders slide out in order on a flat surface. Be sure to let the cylinders slide out slowly, and close to the table surface for the best effect. The red cylinder that the audience saw you put in last, magically comes out first!

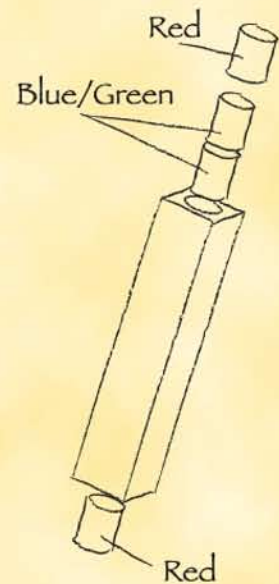

Magic Coin Box

Trick: The magician takes a uniquely marked coin from an audience member and in an instant produces a sealed box that the spectator opens to find another sealed box, and inside that finds a sealed bag, and inside that, to his or her amazement, finds the uniquely marked coin.

How It's Done: A special plastic slide is used to insert the coin. Begin setting up by following the steps below. The set-up is done out of view and before the trick. After the trick is set up and hidden, ask an audience member to mark a coin any way they want to make it unique. Take the coin and in a quick, smooth motion, (out of view) insert it into the exposed end of the plastic slide, remove the slide from the assembly and give the box to the observer to open. They will be amazed!

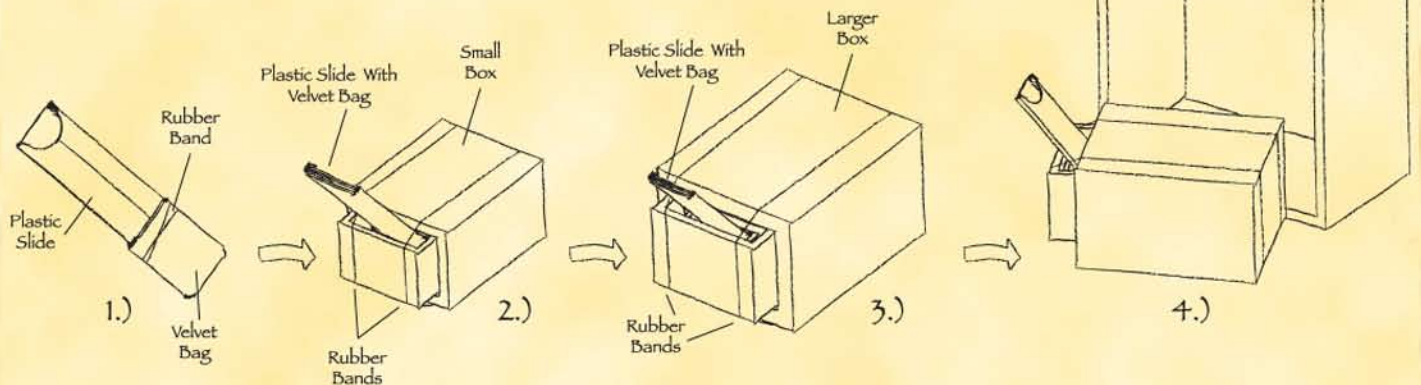

Secret Silks

Trick: Make silks placed in a velvet bag disappear.

How it's Done: The secret here is that the inside of the velvet bag has a double lining that can be moved with a lever that is hidden under the handle. Begin the trick by holding the handle in your right hand, and with your pointer finger wrapped under the handle making sure that the lever is pushed towards you. When the lever is in this position, the bag can be passed straight through when the zipper is opened on the bottom of the velvet bag. Show your audience that they can see straight through the bag and there is nothing in it. Zip the bottom of the bag and then discretely move the lever to the opposite position. Now take one or two of the included silks and show the audience you are putting them into the bag. As you are stuffing the last one with one hand, use that as a distraction and move the lever back into the original position. Magically wave your hand over the top of the bag, unzip the bottom and show the audience the silks are gone!



Vanishing Zone

Trick: Make anything that passes through this box vanish.

How it's Done: This is a trick that should be done at eye-level to the observer for best results. Simply pass the magic wand through the holes on the sides and when viewed from the front, it will appear as though whatever portion of the wand is in the box vanishes!

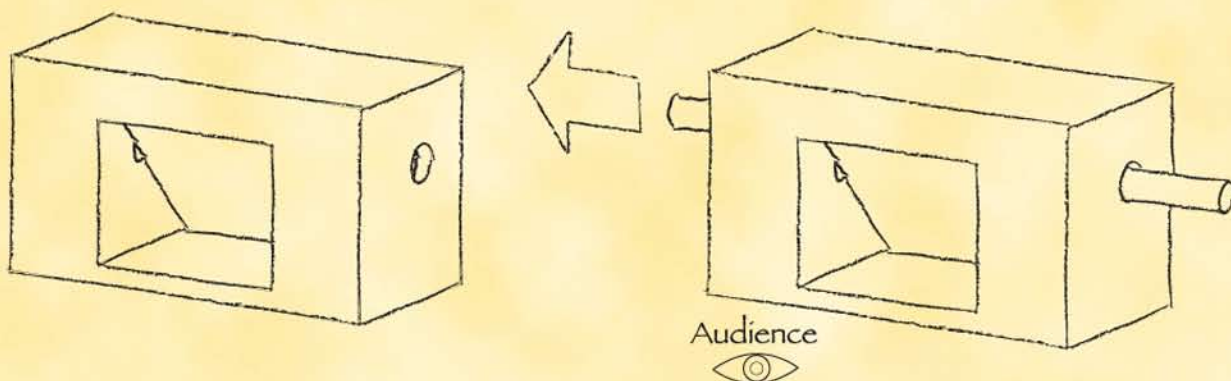

Money Maker

Trick: Coins magically multiply.

How it's Done: First, out of view from any observers, put two or three quarters in the slot that is hidden in the base of the bowl (1). Keep this slot out of view by keeping it facing you. Now place one quarter in the bowl and demonstrate to onlookers that the bowl contains only one quarter and your hands are empty. Now pivot the slotted side of the bowl toward you to pour its contents into your hand (2). The quarters that were hidden inside will magically appear in your hand along with the one that was seen by the audience.

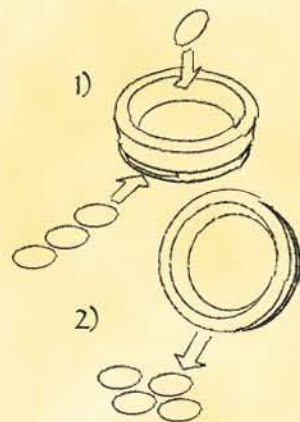

Egyptian Prediction (The One Before Trick)

Trick: Predict the order in which five discs will be placed by an observer.

How It's Done: This trick may be the hardest in the set and will take practice to master. The secret here is that you have one extra disc that is blank and rubber. There are two of each of the discs with pictures on them. Divide the discs into two piles with the same pictures in each. The pile the audience member uses has all five images facing up, and the pile the magician uses has the discs with the pictures facing down. Keep the magician's pile semi-hidden from view in your hand. Keep the blank rubber disc palmed in your hand as you take your pile of discs (the audience must not see the rubber disc palmed in your hand). Ask an audience member to come up and tell them you will predict the order they will put their discs in the chamber. The magician is the first one to place a disc, but it is the blank one. Place the discs in a way that hides them from view (such as from the palm of your hand) so it is not clear how many you have in your hand. The audience member now places any one of their discs face up in the other hole in the chamber. After they place their disc face up you can see which one they used. Put this one in next on top of the blank disc, face down. (Feel free to shuffle through your discs like you are really deciding which one to use). Alternate in this fashion until the audience member has only one disc left. At this point you have two discs in your hand. Keep them hidden from view so it appears you only have one. You now must place the two discs at the same time but make it appear you are only placing one. Be sure they are placed in the correct order. After the audience member places their last disc, carefully turn the chamber over so as not to jar the blank rubber disc loose, and show that the piles are in the same order!

