

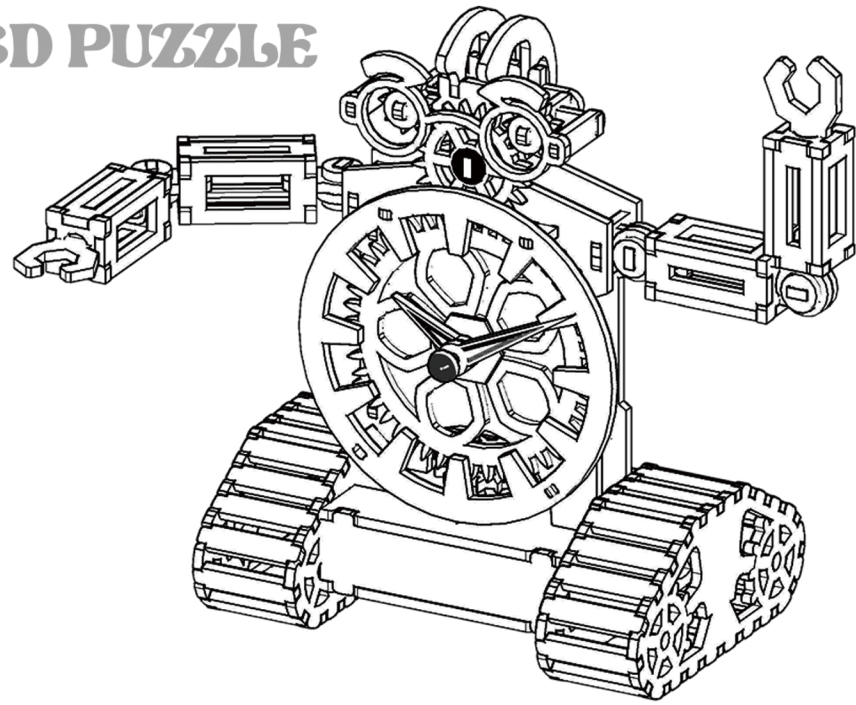

# 3D PUZZLE



1.

Insert according to the card position indicated by the arrow.

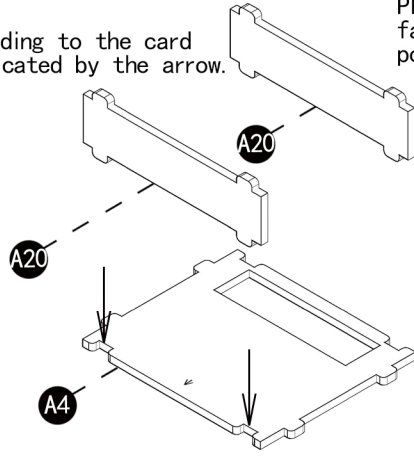

Place B2 on top of A4, and fasten A3 in the matching position.

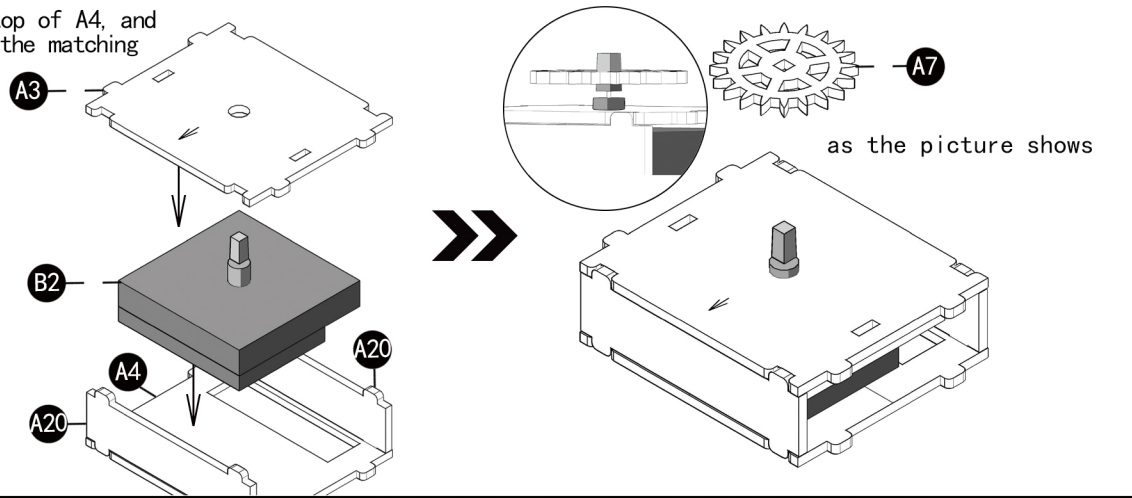

2.

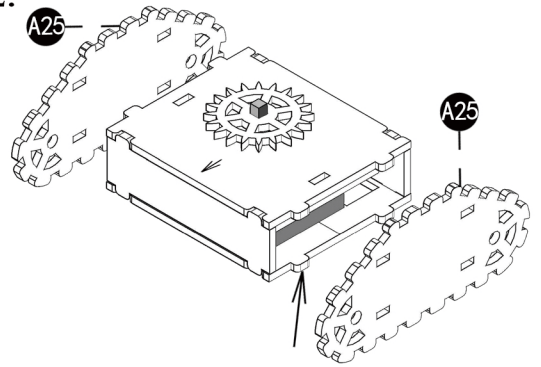

According to the card position indicated by the arrow, the left and right sides of the A25 can be pressed in sequence.

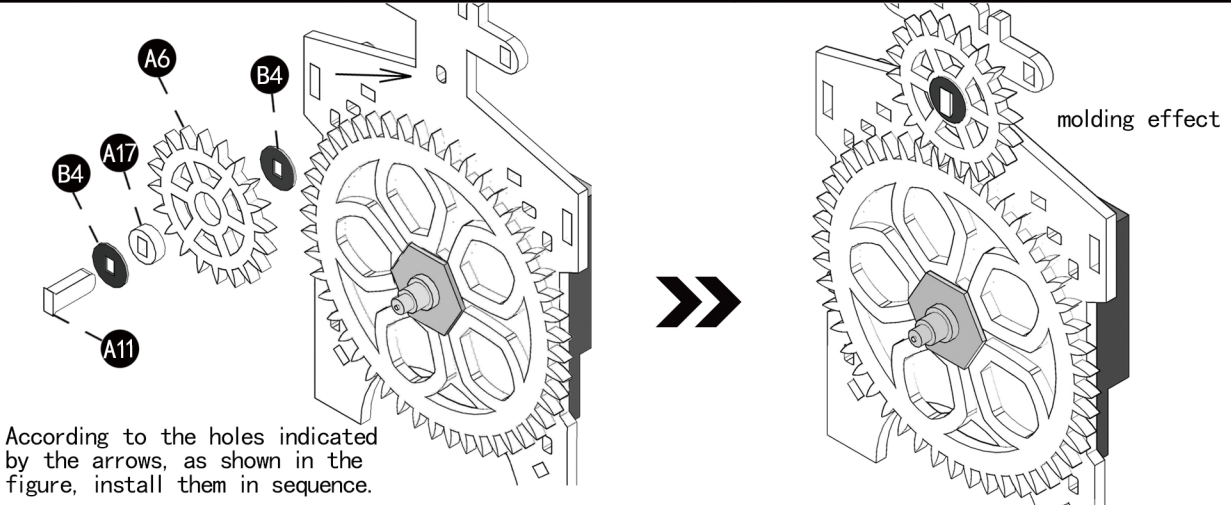
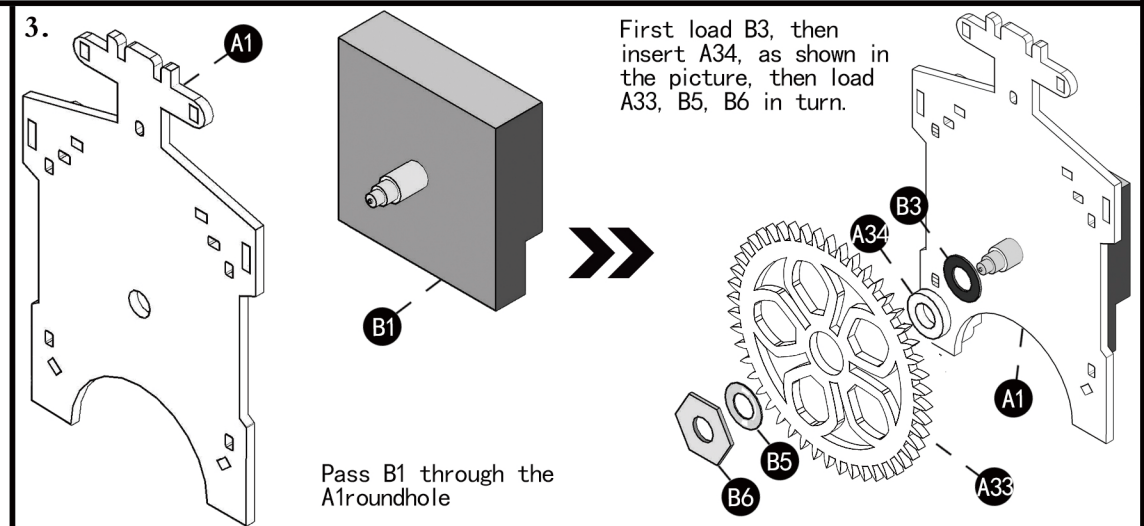
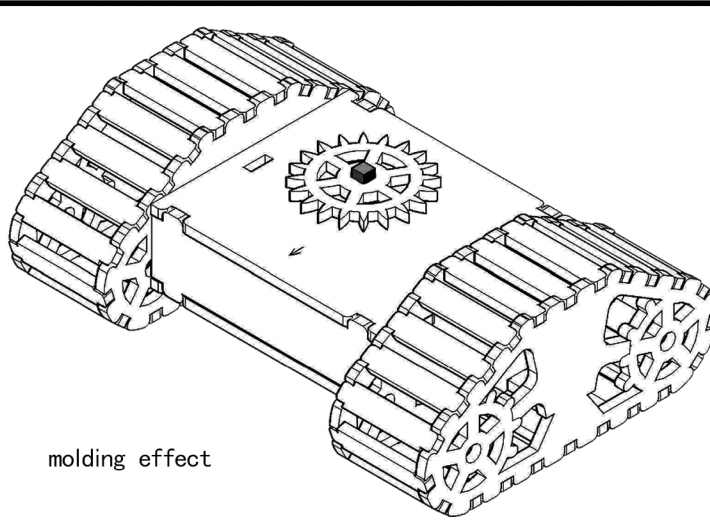
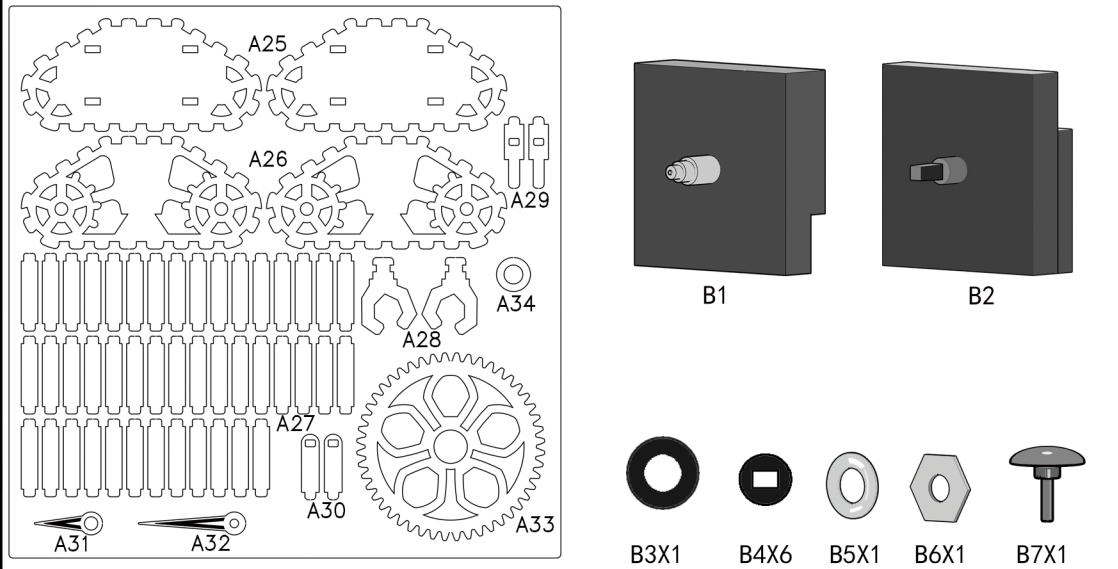
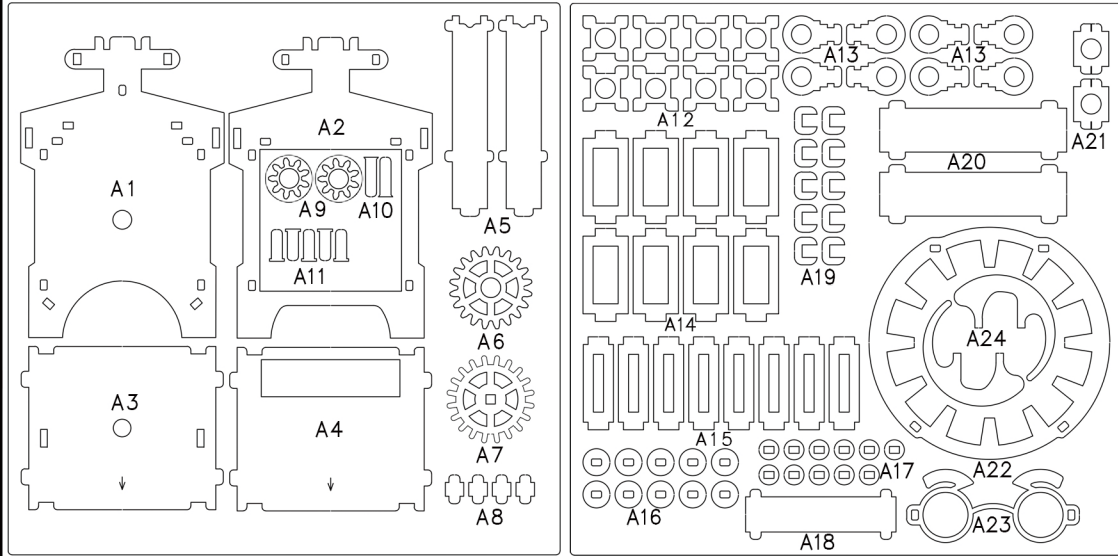
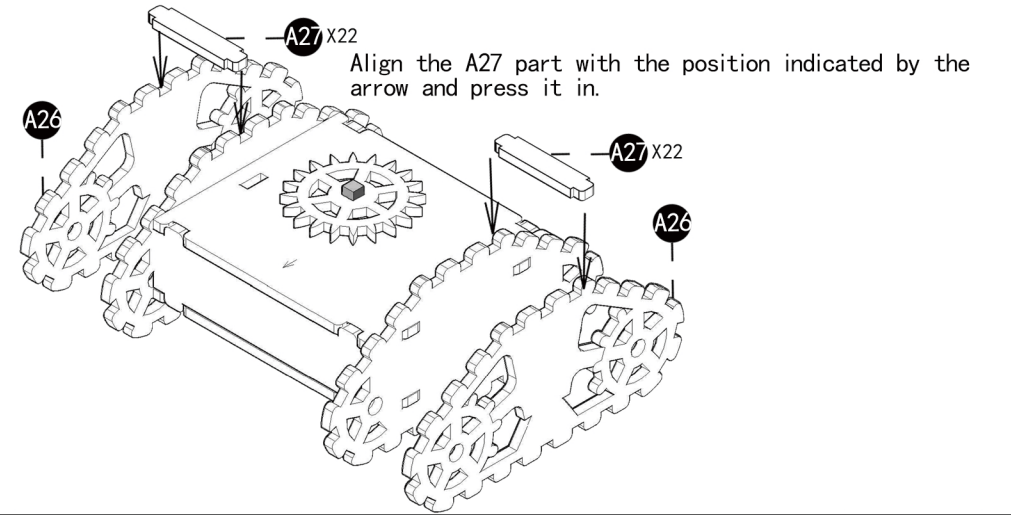

According to the holes indicated by the arrows, as shown in the figure, install them in sequence.

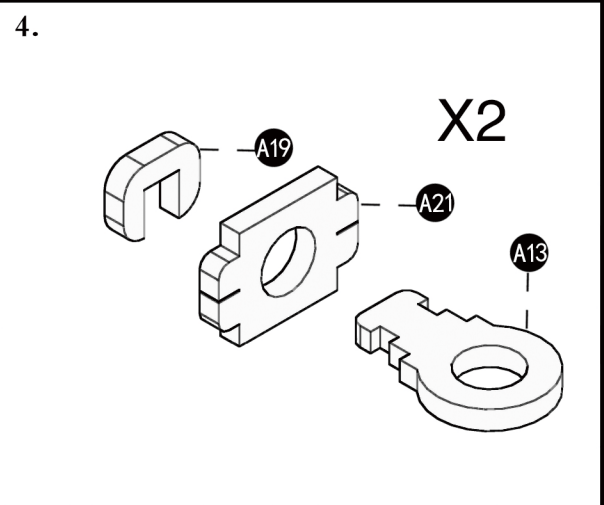

- ① Remove the model and polish off the remaining burrs
- ② Gear and gear center hole must be polished with sandpaper.

