

PROJECT REF:	Fix-it Foot
UNIT REF:	N/A
FOOT PRESSURE:	N/A
UDL:	N/A

Material grade: BS EN 10219-1:2006 (S235JR). Welding standard: BS EN ISO 15614-1. Galvanizing standard: BS EN ISO 1461:2009
 Reference specification document "Custom Fabrication Specification" (BF-SPEC-050411) for further information
 Reference specification document "Big Foot Systems Cross Bar Specification (BF-SPEC-230610) for further information

Fix-it Foot											
Part No.		B6735	B6736	B6737	B9096	B9043	B9045	B9368	B6974	B6973	
Description		Fix-it Foot 250	Fix-it Foot 400	Fix-it Foot 600	Fix-it Foot 1000	Fix-it Foot Low 250	Fix-it Foot Low 400	Fix-it Foot Low 500	High Bloc 600	High Bloc 1000	
X	Overall Length	mm	250	400	600	1000	250	400	500	600	1000
		inches	9 13/16	15 3/4	23 5/8	39 3/8	9 13/16	15 3/4	19 11/16	23 5/8	39 3/8
Y	Overall Width	mm	180	180	180	180	130	130	130	180	180
		inches	7 1/16	7 1/16	7 1/16	7 1/16	5 1/8	5 1/8	5 1/8	7 1/16	7 1/16
Z	Height	mm	95	95	95	95	50	50	50	120	120
		inches	3 3/4	3 3/4	3 3/4	3 3/4	1 15/16	1 15/16	1 15/16	4 3/4	4 3/4
Weight		kg	2.4	3.5	5.8	9.9	1.3	2.1	2.5	10.2	17.7
		lbs	5.3	7.8	12.7	21.9	2.9	4.5	5.4	22.4	38.9
Design Load		kg	82	128	224	295	82	128	134	224	295
		lbs	181	282	494	650	181	282	295	494	650

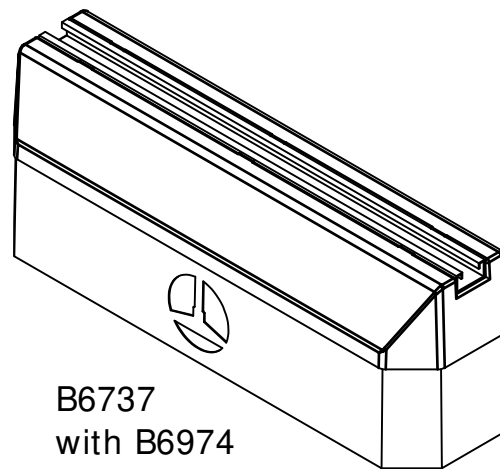
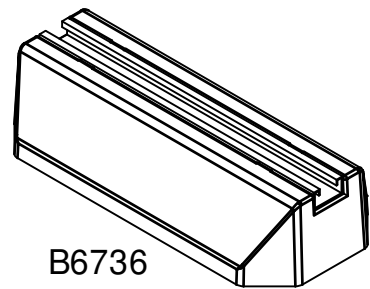
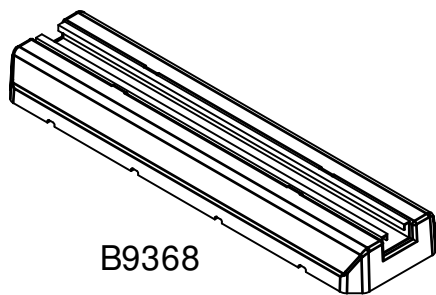
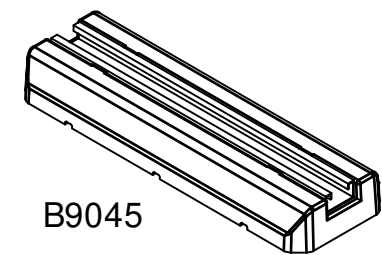
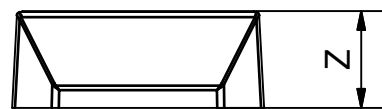
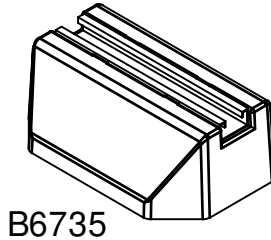
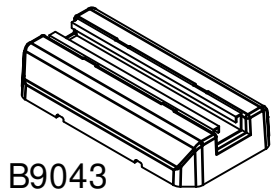
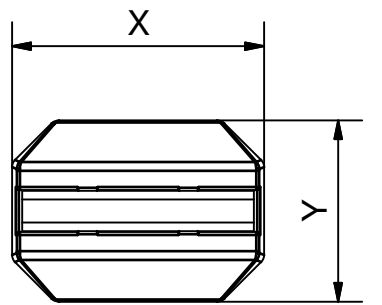

Mini Split Kit (Includes 2 Fix-it Feet & Fast Fix Bolts)		
Part No.	B9284	B9530
Size	600	1000

Working conditions: Suitable for internal or external applications in temperatures between -40°C to +80°C



B9171
Fast Fix Fixing Bolt (M10)

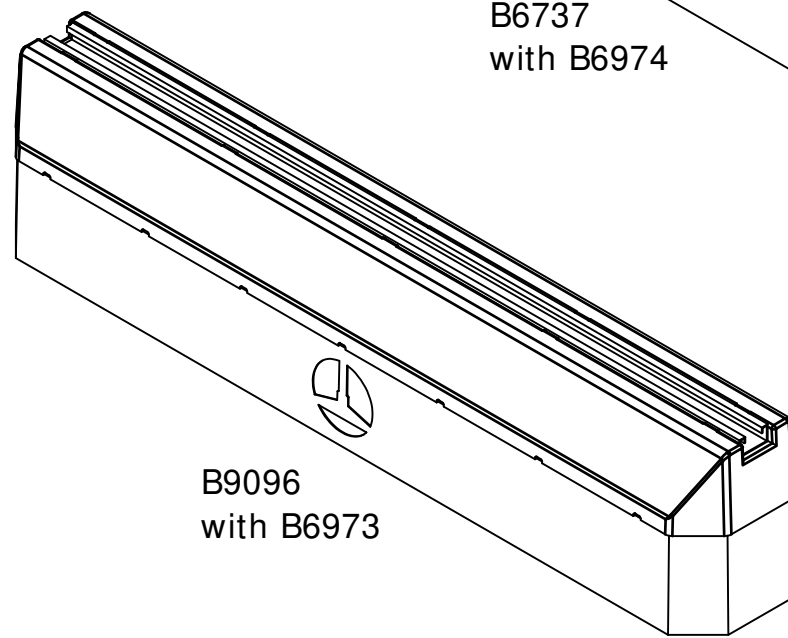

Material Specification				
Part/Description	Material	Regulation Conformance	Density	
			kg/m3	lbs/ft3
Fix-it Foot	Rubber	BS7188:1989	650-1020	41-64
	Aluminium	-	2700	169

Installation and application considerations should include health, safety and environmental needs, regulations and standards, codes of practice, climate conditions, installation location, product orientation, evaluation of the roof structure, composition, surface and condition, ancillary and complimentary products and materials. Big Foot Systems recommend that all rooftop products are handled and installed by suitably qualified persons. All scheme designs are based on the use of Big Foot Systems' products and materials only. Terms and conditions available on request

REV B	DATE:	20/10/2016	SCALE: 1:20	A3
	DRAWN:	A SIMMANS		
	CHECKED:	S BIRCH		
			DIMENSIONS IN mm U.O.S	
			TOLERANCES: 0.0 ± 0.5mm U.O.S	
			SHEET 1 OF 1	

TITLE:	Fix-it Foot Product Information Sheet
DWG No.	BFP-FIF.dwg
THIS DRAWING IS COPYRIGHT AND THE PROPERTY OF BIG FOOT SYSTEMS LIMITED	

