

# CHiQ

## Refrigerator

MODEL:FBM351NEI42

|  |                |
|--|----------------|
| CLIMATE CLASS                              | SN/N/ST/T      |
| RATED VOLTAGE                              | 220-240V~      |
| RATED CURRENT                              | 1.0A           |
| RATED FREQUENCY                            | 50HZ           |
| Defrosting Power                           | 170W           |
| ENERGY CONSUMPTION OF E <sub>16</sub>      | 0.412kWh/24h   |
| ENERGY CONSUMPTION OF E <sub>32</sub>      | 0.920kWh/24h   |
| LAMP POWER                                 | MAX 5W         |
| REFRIGERATOR STORAGE VOLUME                | 257L           |
| FREEZER STORAGE VOLUME                     | 94L            |
| INSULATION BLOWING GAS                     | Cyclopentane   |
| CLASS OF PROTECTION AGAINST ELECTRIC SHOCK | Class I        |
| REFRIGERANT/AMOUNT                         | R600a/42g      |
| FREEZING CAPACITY                          | 4.3kg/24h      |
| TEMPERATURE RISE TIME                      | 7h             |
| NET WEIGHT                                 | 67Kg           |
| PRODUCT DIMENSIONS(W*D*H)                  | 595x635x2000mm |

### Diagram of Circuit Principles

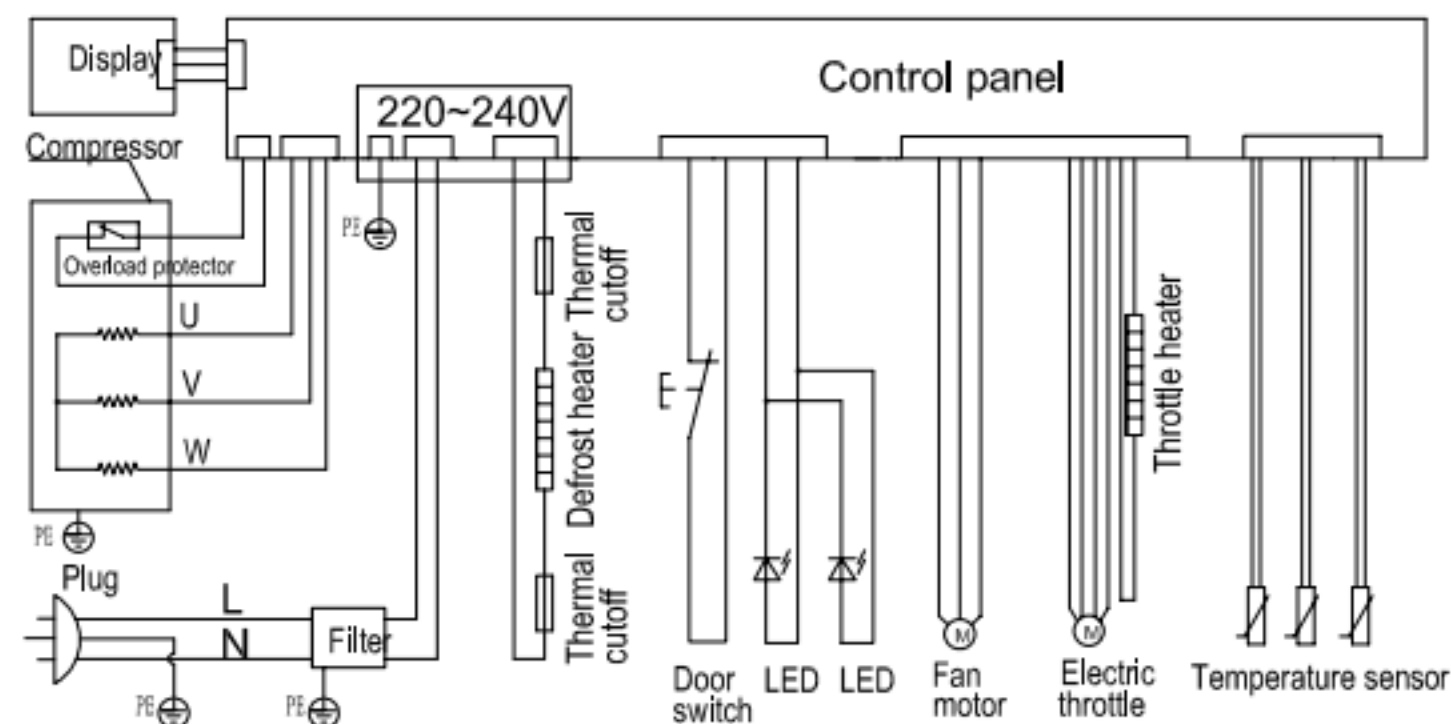

Made in PRC

Serial Number:

