

Wisoppervlakken
Wiping surfaces
Wischoberflächen
Surfaces d'essuyage
Superficies de barrido
Superficie di pulitura

80°

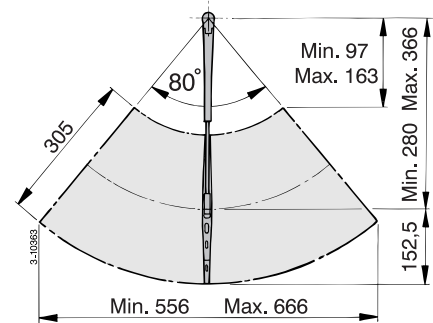

110°

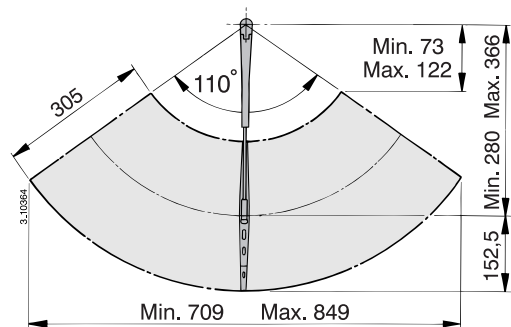

1

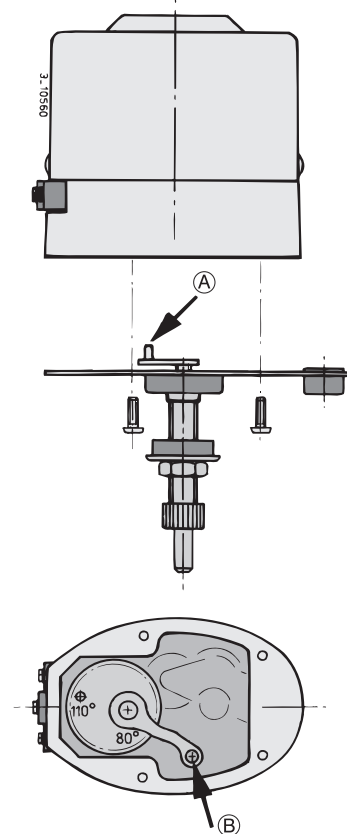

Aansluitschema
Wiring diagram
Anschlußschema
Schéma de raccordement
Esquema de conexión
Schema di collegamento

2

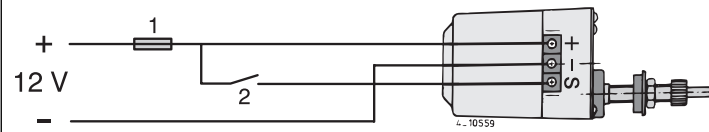

3

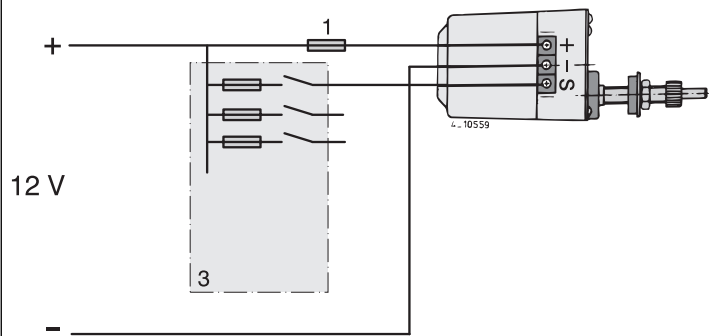

1 Zekering
2 Schakelaar
3 Schakelpaneel

1 Fusible
2 Interrupteur
3 Tableau de commande

1 Sicherung
2 Schalter
3 Schaltkasten

Wetust Windscreen wiper motor ORW, Wiper arm AS, Wiper blade BS

Hoofdafmetingen
Overall dimensions
Hauptabmessungen
Dimensions principales
Dimensiones principales
Dimensioni principali

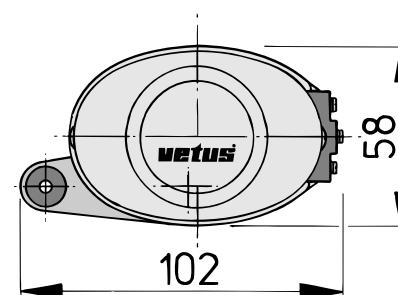
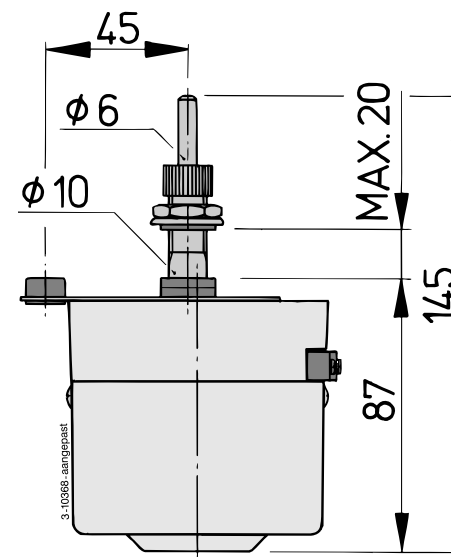

vetus den ouden n.v.

FOKKERSTRAAT 571 - 3125 BD SCHIEDAM - HOLLAND - TEL.: +31 10 4377700 - TELEX: 23470
TELEFAX: +31 10 4372673 - 4621286 - E-MAIL: sales@vetus.nl - INTERNET: http://www.vetus.com

Printed in the Netherlands
110210.07 02-05

Installatie instructies
Installation instructions
Installationsanleitung
Instructions d'installation
Instrucciones de instalación
Istruzioni per l'installazione

vetus

Ruitenwissers

Windscreen wipers

Scheibenwischer

Essuie-glaces

Limpiaparabrisas

Tergicristalli

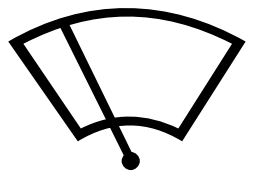

ORW
(12 V)

Copyright © 2005 Vetus den Ouden n.v. Schiedam Holland

