



- GB Suitable for outdoor installation.
- NL Geschikt voor montage buiten.
- F Conçu pour montage à l'extérieur.
- D Geeignet für die Außenmontage.
- S Lämpad för montering utomhus.
- DK Eignet til montage udendørs.
- FIN Soveltuu asennettavaksi ulos.
- PL Urządzenie przeznaczone do instalacji zewnętrznej.
- RUS Для использования вне помещений.
- BG Подходящо за външно монтиране.
- H Külszo telepítésre alkalmas.
- RO Adecvat montării în spații exterioare.
- SK Vhodné pre vonkajšiu inštaláciu.
- HR Prigodno za instalaciju u eksterijerima.
- CZ Vhodné pro venkovní instalaci.
- SLO Primerno za zunanjo montažo.
- I Adatto per montaggio all'esterno.
- P Adequado para instalações externas.
- E Apto para la instalación al aire libre.
- GR Κατάλληλο για εξωτερική εγκατάσταση.
- TR Açık hava tesisatına uygundur.

- GB The fitting is splash-proof.
- NL Het armatuur is spatwaterdicht.
- F L'armature est étanche aux projections d'eau.
- D Die Armatur ist spritzwasserdicht.
- S Armaturen är tät mot stänkvatten.
- DK Armaturet er stænktæt.
- FIN Valaisin on roiskevedenpitävä.
- PL Urządzenie jest bryzgoszczelne.
- RUS Осветительная арматура является брызгозащищенной.
- BG Осветителното тяло е устойчиво на намокряне.
- H A szerezvény fröccsenésálló.
- RO Corpul de iluminat este rezistent la stropiere.
- SK Zariadenie je chránené proti postriekaniu.
- HR Svjetiljka je zaštićena protiv štrcanja vode.
- CZ Zařízení je chráněno proti postřiku.
- SLO Nosilec je odporen proti curkom.
- I La lampada è protetta contro gli spruzzi d'acqua.
- P A ferragem de conexão é a prova de salpicos.
- E El montaje está protegido contra salpicaduras.
- GR Η εφαρμογή είναι αδιάβροχη στα πισισλιόματα.
- TR Tertibat sıçramalara karbı dayanıklıdır.



- GB Strip the wire to the indicated length.
- NL Strip de draad op lengte zoals aangegeven.
- F Dégagez le fil sur la longueur, comme indiqué.
- D Isolieren Sie den Draht auf der angegebenen Länge ab.
- S Skala ledaren över den angivna längden.
- DK Strip ledningen i længden som vist.
- FIN Kuori johto kuvassa ilmoitetulla pituudella.
- PL Rozciągnąć przewód do wymaganej długości.
- RUS Зачистите провод до требуемой длины.
- BG Ogolete kabela do posочената дължина.
- H Csupaszolja le a vezetékét a jelzett hosszig.
- RO Dezizolabi firul la lungimea indicată.
- SK Skráťte vodič na určenú dĺžku.
- HR Ogulite kabel do tražene duljine.
- CZ Zkraťte vodič na určenou délku.
- SLO Ogulite izolacijo žice do navedene dolžine.
- I Spellare il filo sulla lunghezza indicata.
- P Desencape o fio no comprimento indicado.
- E Pelar el cable a la longitud indicada.
- GR Αποσυναρμολογήστε το καλώδιο στο αναγραφόμενο μήκος.
- TR Belirtilen uzunluğa kadar telin kaplamasını soyunuz.

- GB Connect using the specified cable.
- NL Aansluiten met de voorgeschreven kabel.
- F Raccorder avec le câble requis.
- D Anschließen mit dem vorgeschriebenen Kabel.
- S Anslut med den föreskrivna kabeln.
- DK Skal tilsluttes med den foreskrevne kabel.
- FIN Liitettävä kuvassa ilmoitetulla kaapelilla.
- PL Podłączenie należy wykonać za pomocą zalecanego przewodu.
- RUS Выполняйте подключение с использованием указанного кабеля.
- BG Свържете като използвате посочения кабел.
- H Csupaszolja le a vezetékét a jelzett hosszig.
- RO Conectabilă utilizând cablul specificat.
- SK Zapojte pomocou určeného kábla.
- HR Za priključak koristite specijalne kablove.
- CZ Zapojte pomocí určeného kabelu.
- SLO Priključite z uporabo navedenega kabla.
- I Collegare con il cavo previsto.
- P Efectue a conexão, usando o cabo especificado.
- E Conectar mediante el cable especificado.
- GR Συνδέστε χρησιμοποιώντας το συγκεκριμένο καλώδιο.
- TR Belirtilen özellikteki kabloyu kullanınız.

TEVEA BV, Lage Zijde 10,
5626 DL Eindhoven - the Netherlands
WWW.TEVEA.NL
Ranex GmbH, Arnsberg - Germany
WWW.RANEX-GMBH.DE

RX1010.20090608

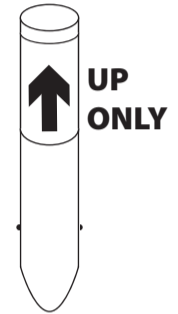

Use Safety Instructions

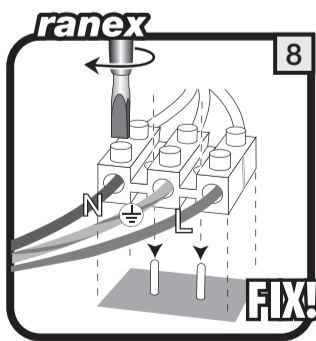
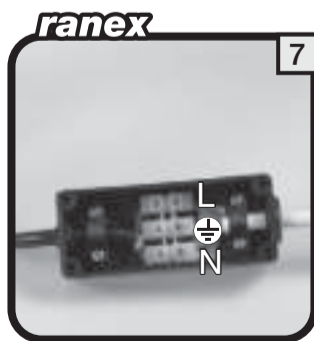
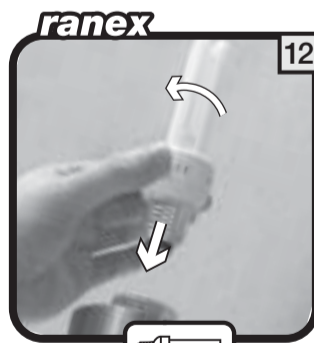
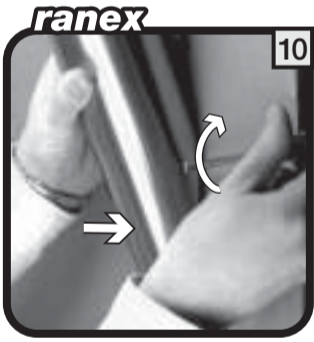
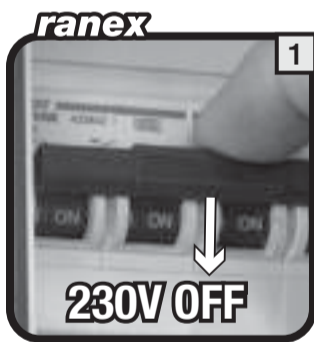

- GB Protection class 1: the fitting must be earthed.
- NL Beschermklasse 1, het armatuur moet geaard worden.
- F Classe de sécurité 1, l'armature doit être mise à la terre.
- D Schutzklasse 1, die Armatur muss geerdet werden.
- S Skyddsklass 1, armaturen måste jordas.
- DK Beskyttelsesklasse 1, armaturet skal have jordforbindelse.
- FIN Suojausluokka 1, valaisin pitää maadoittaa.
- PL Klasa zabezpieczenia 1: urządzenie musi być uziemione.
- RUS Класс защиты 1: арматура должна быть заземлена.
- BG Защита от клас 1: осветителното тяло трябва да е заземено.
- H 1. védelmi osztály: a szerelvény földelhető.
- RO Clasă 1 de protecție: corpul de iluminat trebuie împământat.
- SK Trieda ochrany 1: zariadenie musí byť uzemnené.
- HR Klasa zaštite 1: svjetiljka mora biti uzemljena.
- CZ Třída ochrany 1: zařízení musí být uzemněno.
- SLO Zaščitni razred 1: nosilec senzorja je potrebno ozemljiti.
- I Classe di protezione 1, la lampada deve avere la messa a terra.
- P Classe 1 de protecção: a ferragem de conexão deve ser ligada à terra.
- E Protección de Clase 1: el montaje debe estar conectado a tierra.
- GR Προστατευτικό γυαλί 1: η εφαρμογή πρέπει να γειωθεί.
- TR Emniyet türü 1: Tertibat topraklanmalıdır.