

PARTS & FUNCTIONS

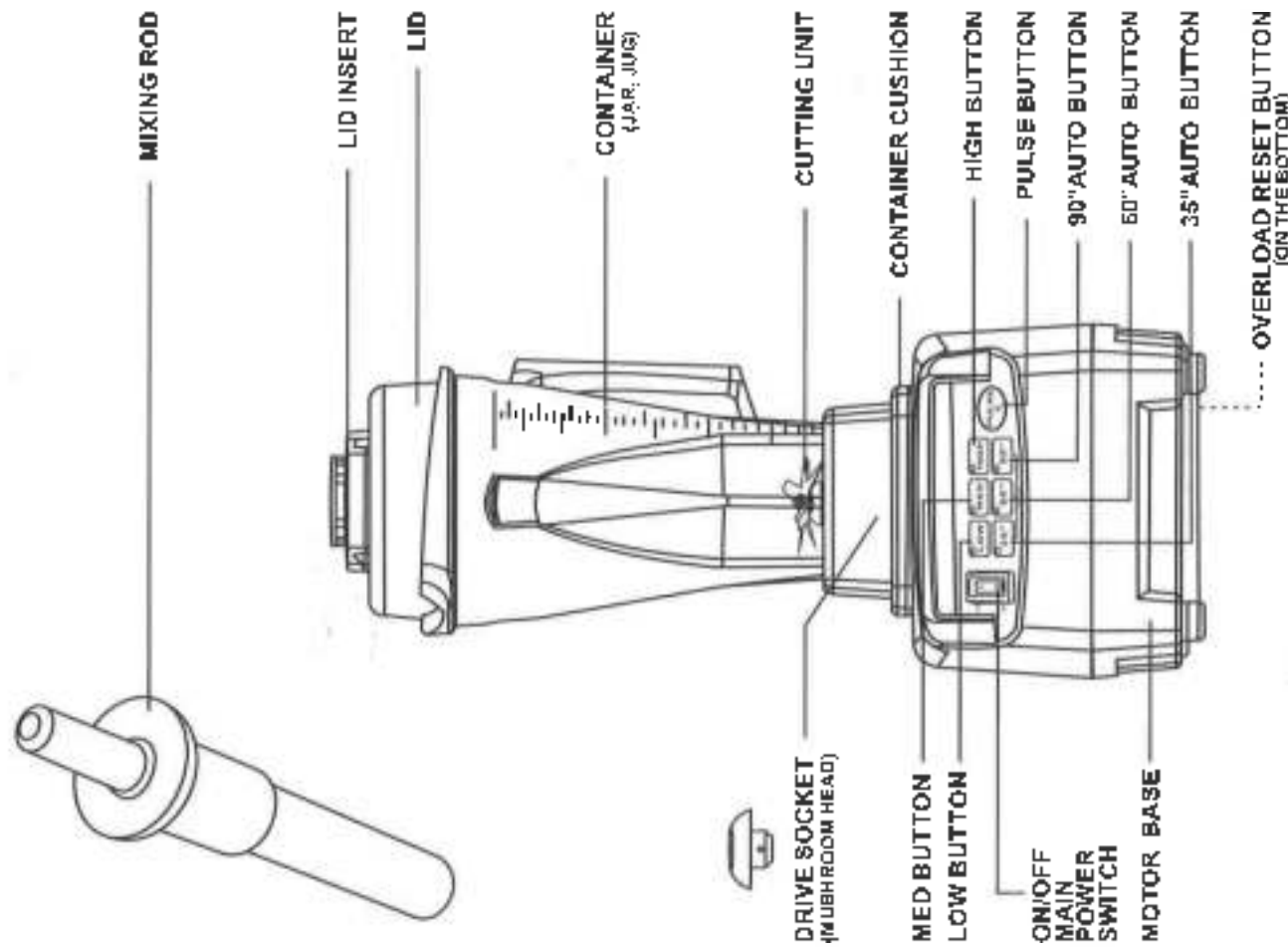

QUICK GUIDE

1. Insert the power plug into an electrical outlet.
2. Turn on the main power switch.
3. Properly fill and place the blender jug on the base, making sure the jug fits securely and the lid is tightly attached.
4. Manual operation: select HIGH, MED, LOW, (these selections will cause the blender to blend continuously at the predetermined speed) or PULSE (PULSE is the fastest speed when pressing the switch and holding down as needed).
5. Automatic cycle operation: press 35", 60", or 90" for automatic blend and shut off. Automatic blending cycles will blend at various speeds for a predetermined period of time, perfect for a quick smoothie or iced drinks, predominantly in a busy commercial environment.
6. There is a red LED display during the cycle, and a long beep signals the end of the automatic cycle.

NOTE: To stop the operation at any time, press any button.

OPERATING INSTRUCTIONS

1. Operate blender on a flat, clean, and dry surface.
2. Never operate the blender when the jug is empty.
3. Do not attempt to remove or replace the jug while the motor is running.
4. Never run motor while jug is not in place.
5. Wipe water off of the cushion before operation. Any water present could be pulled in and will cause damage to the motor.
6. Make sure the drive shaft on the jug is fully engaged into the drive socket and that the blade is firmly affixed to the drive shaft.
7. This blender is a high-speed unit. Blending times are much faster than those of other blenders, but extended use will heat up the contents of the blender.
8. If drink has mixed well but not blended completely, press PULSE for extra blending time or choose a longer automatic cycle.
9. Always add some liquid to crush ice cubes.

CLEANING

Warning: Unplug the power cord to ensure safety.

1. Place a little warm water with a small amount of detergent into the jug. Attach lid and switch blender on for approximately 10 seconds. This will remove almost all residue. Empty jug, rinse, and leave upright to dry.
2. Do not clean inside of jug by hand unless cutting unit has been removed. To remove or replace blade assembly, simply turn the retaining ring at the bottom of the jug counter-clockwise.
3. To clean motor base, use a slightly damp cloth only. Never immerse motor base in water.
4. To extend the lifespan of the cutting unit, please do not immerse the jug in water or leave water in the jug for a long period of time. Following this precaution will help prevent rusting of the ball bearing by reducing its potential contact with water to a minimum.

PARTS & FUNCTIONS

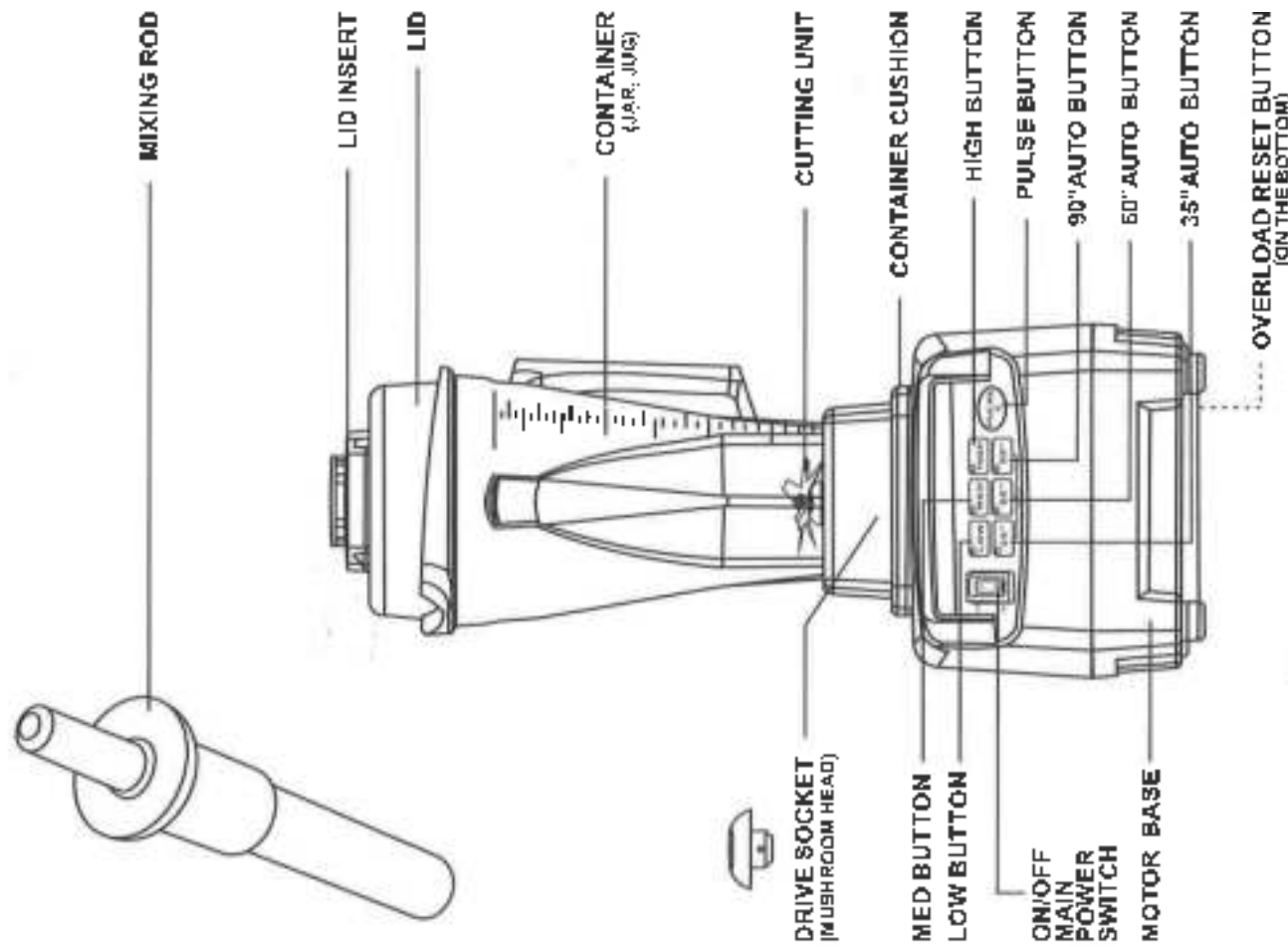

QUICK GUIDE

1. Insert the power plug into an electrical outlet.
2. Turn on the main power switch.
3. Properly fill and place the blender jug on the base, making sure the jug fits securely and the lid is tightly attached.
4. Manual operation: select HIGH, MED, LOW, (these selections will cause the blender to blend continuously at the predetermined speed) or PULSE (PULSE is the fastest speed when pressing the switch and holding down as needed).
5. Automatic cycle operation: press 35", 60", or 90" for automatic blend and shut off. Automatic blending cycles will blend at various speeds for a predetermined period of time, perfect for a quick smoothie or iced drinks, predominantly in a busy commercial environment.
6. There is a red LED display during the cycle, and a long beep signals the end of the automatic cycle.

NOTE: To stop the operation at any time, press any button.

OPERATING INSTRUCTIONS

1. Operate blender on a flat, clean, and dry surface.
2. Never operate the blender when the jug is empty.
3. Do not attempt to remove or replace the jug while the motor is running.
4. Never run motor while jug is not in place.
5. Wipe water off of the cushion before operation. Any water present could be pulled in and will cause damage to the motor.
6. Make sure the drive shaft on the jug is fully engaged into the drive socket and that the blade is firmly affixed to the drive shaft.
7. This blender is a high-speed unit. Blending times are much faster than those of other blenders, but extended use will heat up the contents of the blender.
8. If drinks has mixed well but not blended completely, press PULSE for extra blending time or choose a longer automatic cycle.
9. Always add some liquid to crush ice cubes.

CLEANING

Warning: Unplug the power cord to ensure safety.

1. Place a little warm water with a small amount of detergent into the jug. Attach lid and switch blender on for approximately 10 seconds. This will remove almost all residue.
2. Empty jug, rinse, and leave upturned to dry. Do not clean inside of jug by hand unless cutting unit has been removed.
3. To remove or replace blade assembly, simply turn the retaining ring at the bottom of the jug counter-clockwise.
4. To clean motor base, use a slightly damp cloth only. Never immerse motor base in water.
5. To extend the lifespan of the cutting unit, please do not immerse the jug in water or leave water in the jug for a long period of time. Following this precaution will help prevent rusting of the ball bearing by reducing its contact with water to a minimum.