

## 1. Propeller installation

Please make sure that all propellers are installed in the correct orientation as shown in the figure below. If the installation is incorrect, the aircraft will not fly normally.

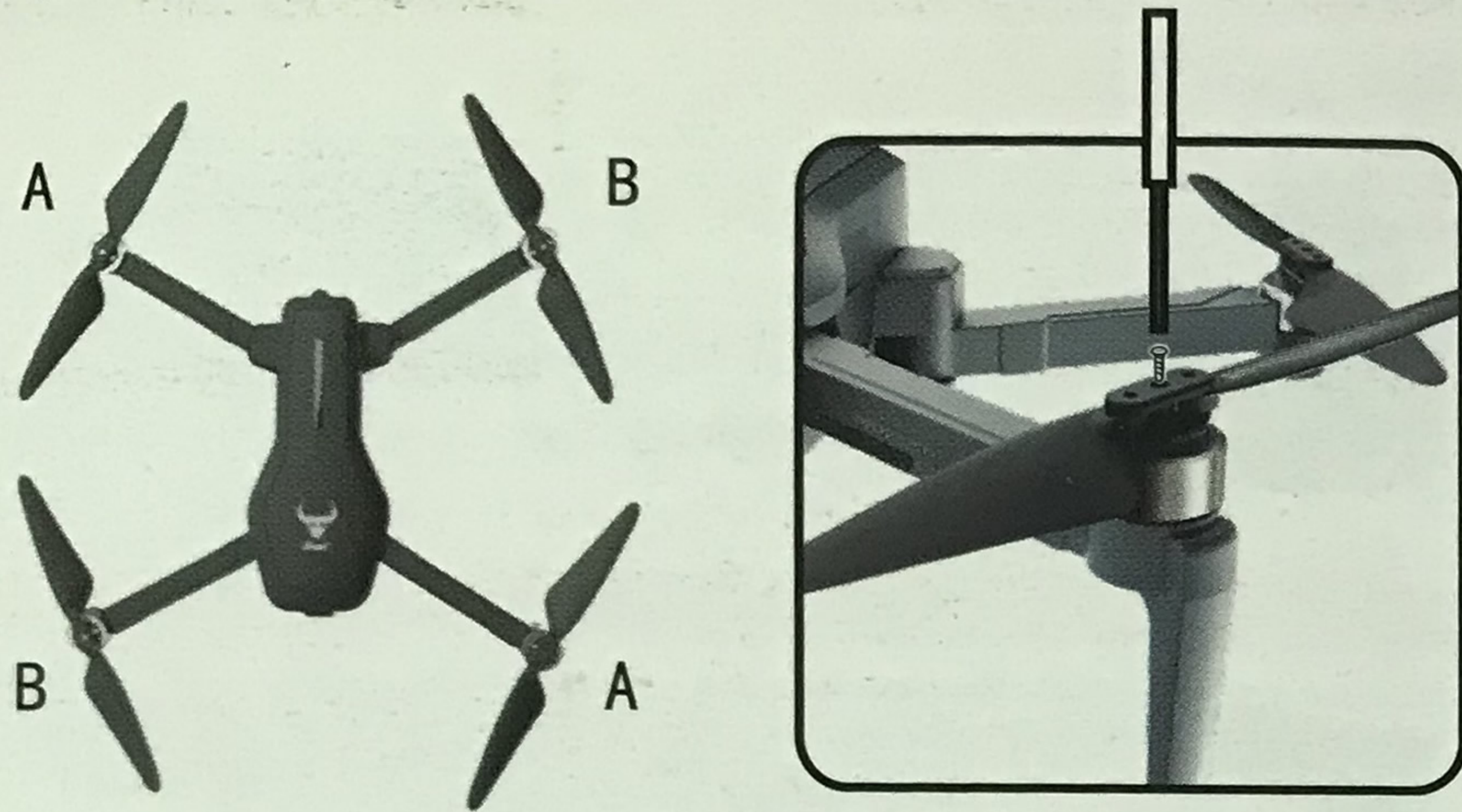

## 2. Aircraft lithium battery

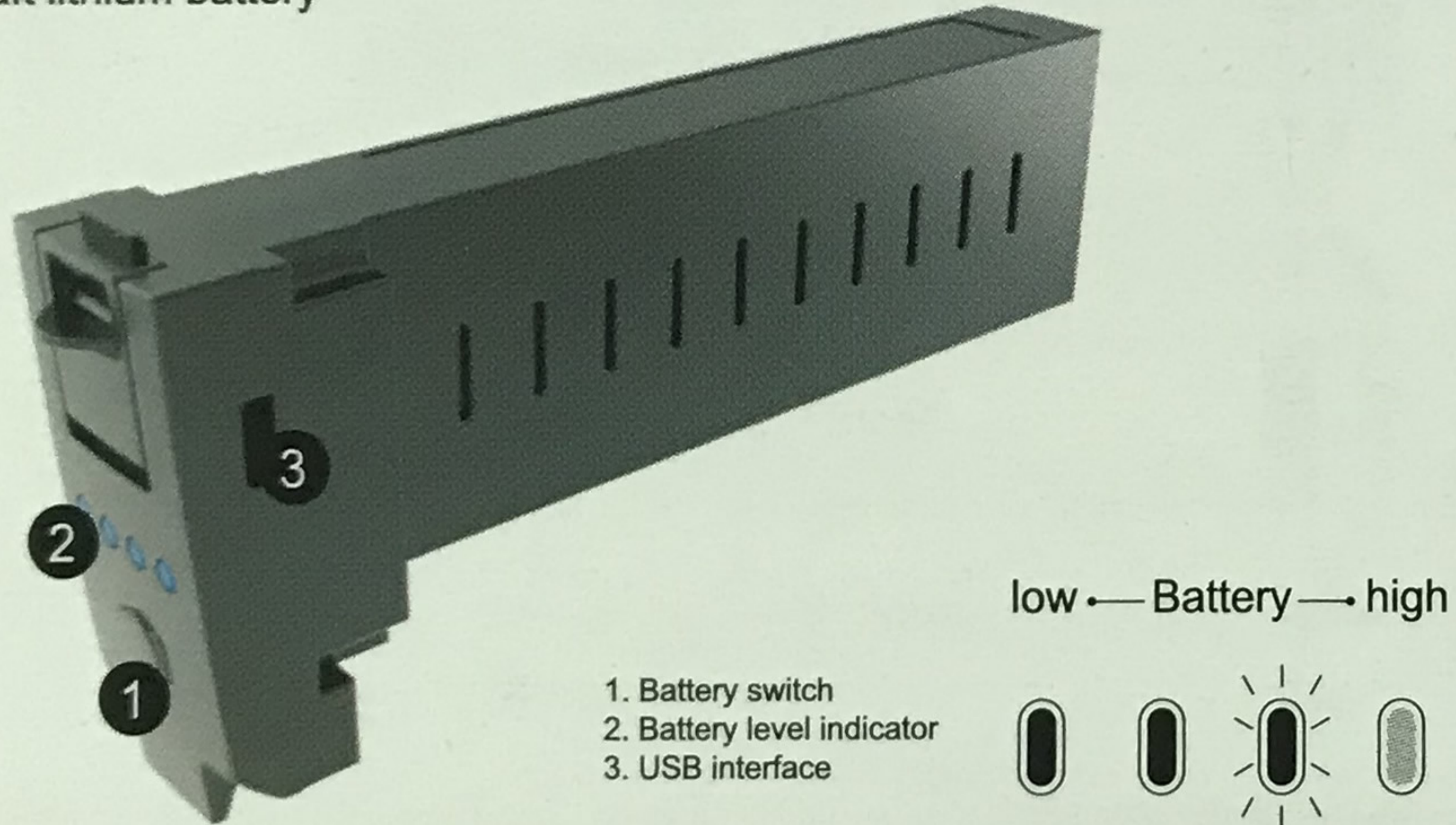

1. Battery switch
2. Battery level indicator
3. USB interface

-Press and hold the power button for 3 seconds to turn on, and then press and hold the power button for 3 seconds to turn off.

-Once the battery is in a low power state, and there is 1 light left in the battery indicator, please charge the battery immediately to avoid unnecessary losses.

## Battery installation

Press the battery button down, and then push the battery into the drone battery holder. After the installation is complete, the battery clip will pop up and check to ensure that the battery is in place.

**⚠ Tips:** If the battery is not installed properly, it is likely to cause a drone to interrupt the power supply and fall accident.

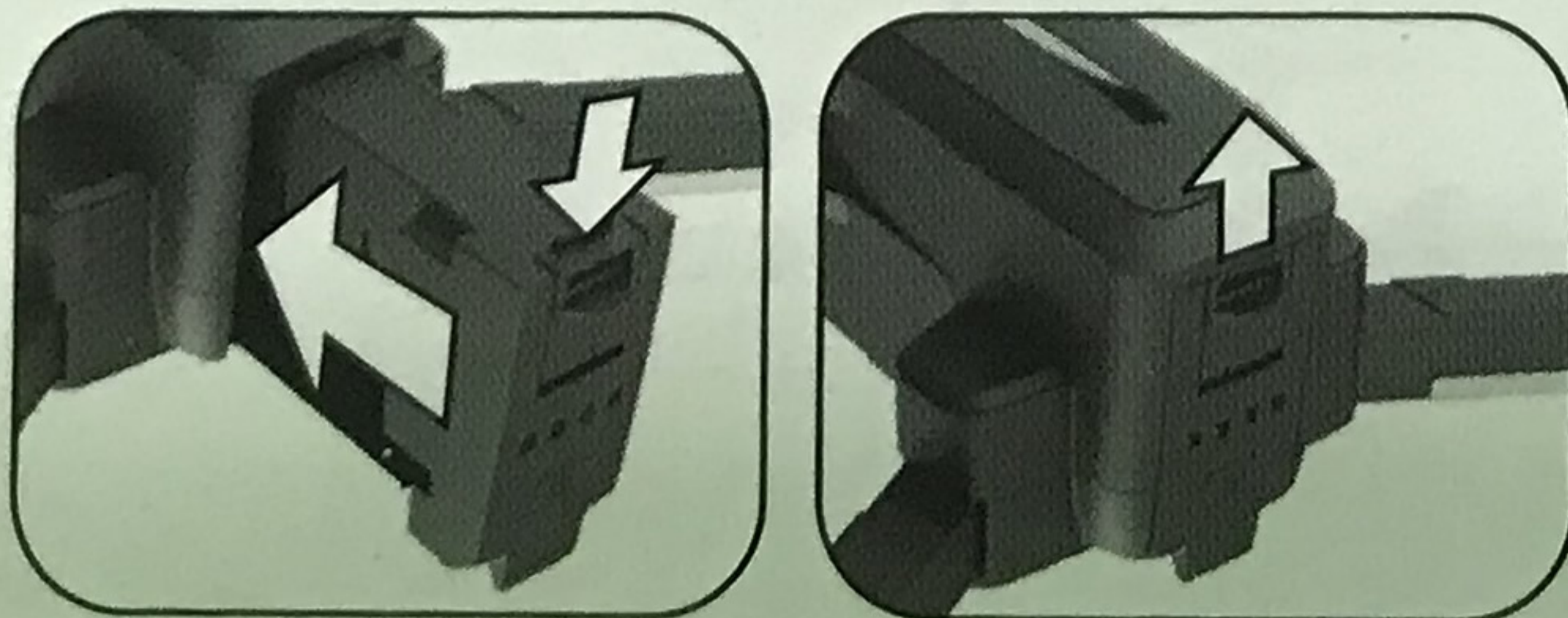

## Battery removal

Press the battery latch and remove the battery backwards. Keep fingers and machine clean and dry before operation, otherwise the battery may not be slipped out.

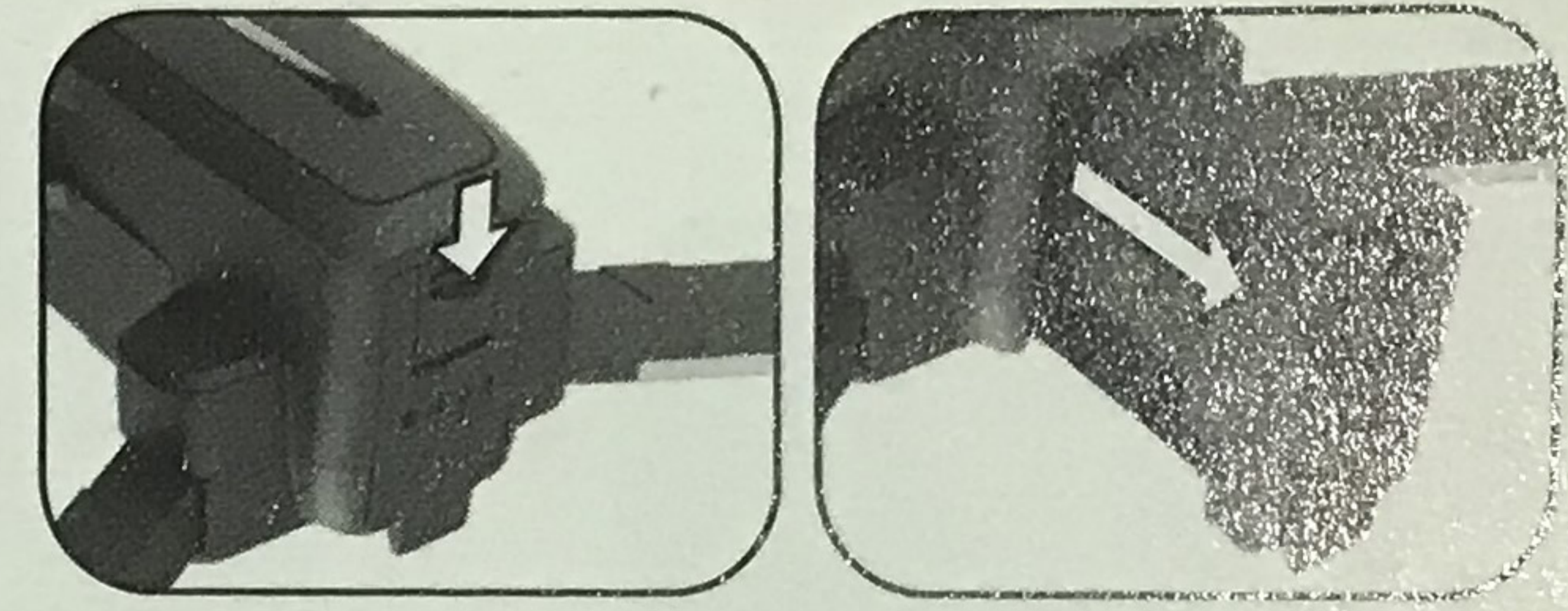

## Drone battery charging

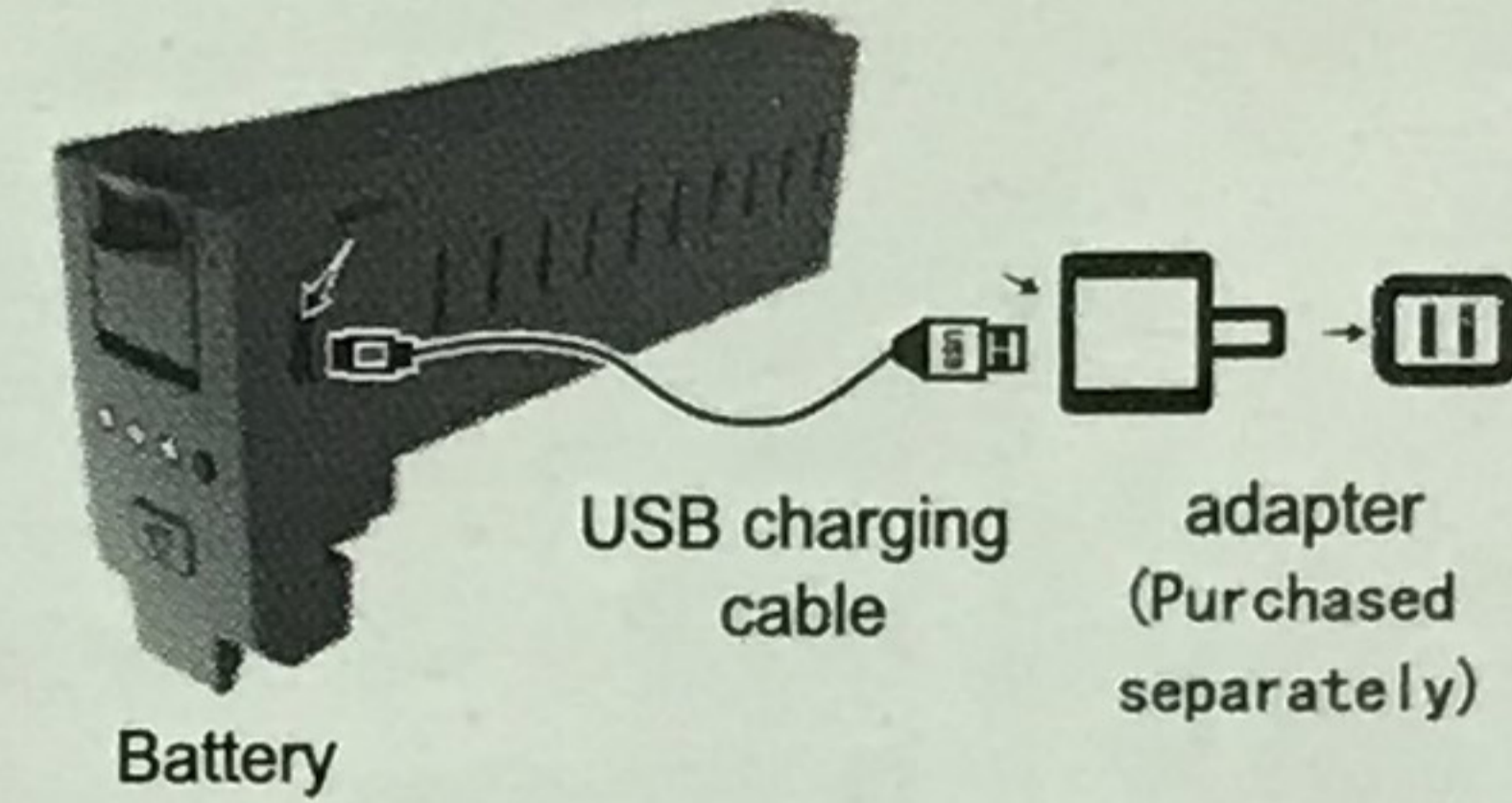

- ⚠ Tips:**
- Insert the plug in the correct way.
  - It is recommended to use 5V 1-2A adapter for charging.

- ⚠**
- When charging the rechargeable battery, do not use it for children alone. It must be carried out under the supervision of an adult. It must be kept away from flammable materials during charging. The guardian should not leave the aircraft outside the surveillance range during charging.
  - Do not short circuit or squeeze the battery to avoid explosion.
  - The power supply terminals should not be taken out of the model, and the terminals should not be short-circuited; do not short-circuit, disassemble or throw the battery into fire; do not place the battery in high temperature and heat places (such as in a fire or near an electric heating device).
  - The model can only use the recommended charger. Regularly check the charger's wires, plugs, shells and other parts for damage. If you find any damage, stop using it until the repair is complete.
  - The charger is not a toy; the charger can only be used indoors.
  - The battery must be charged and stored after the flight. If not in use, it is recommended to charge the battery at least once every 3 months to avoid over-discharging the battery and permanently damaging the battery.

**⚠** Reminder: The camera needs to be used with the real-time transmission APP. For the download process, please refer to the APP manual, and for the camera function description, please refer to the APP.

## 3. PTZ camera control

By turning the PTZ button on the remote control, you can adjust the shooting angle of the PTZ camera to 110° to experience a better aerial photography process.

When the left button is pressed, the camera is adjusted in the direction of A; when the right button is pressed, the camera is adjusted in the direction of B.

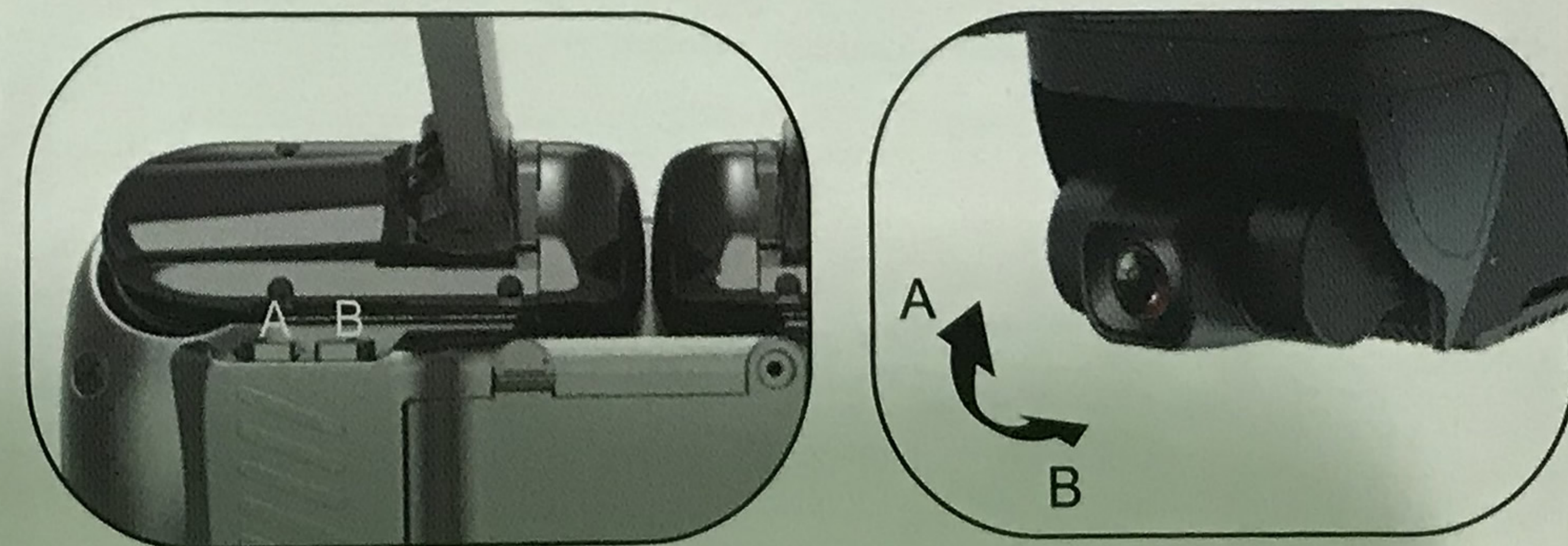

## Remote control part names

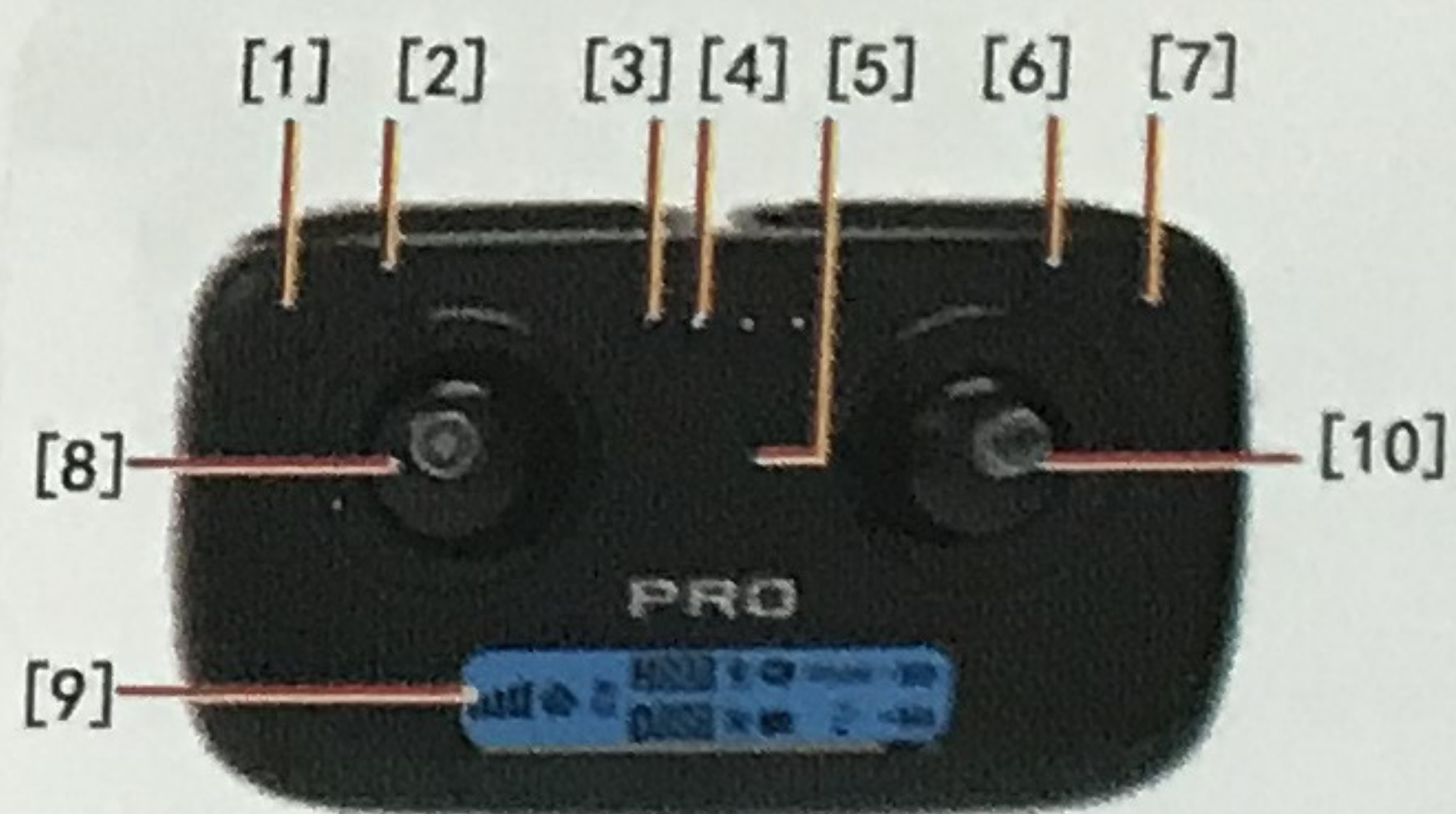

- [1] Speed switch  
(Press and hold 5 seconds for gyroscope and gimbal level correction)
- [2] One touch return
- [3] Red signal light (always on when connected)
- [4] battery level indicator (remote control)
- [5] power switch
- [6] Recording button (long press for 5 seconds to turn off mode 2 [GPS mode])
- [7] Photo button (long press for 5 seconds to correct geomagnetism)
- [8] Ascend, descend, turn left, turn right
- [9] LCD display
- [10] Fly Left and Right



- [11] PTZ up
- [12] PTZ down
- [13] Headless Mode
- [14] Take off and land with one click

## LCD display

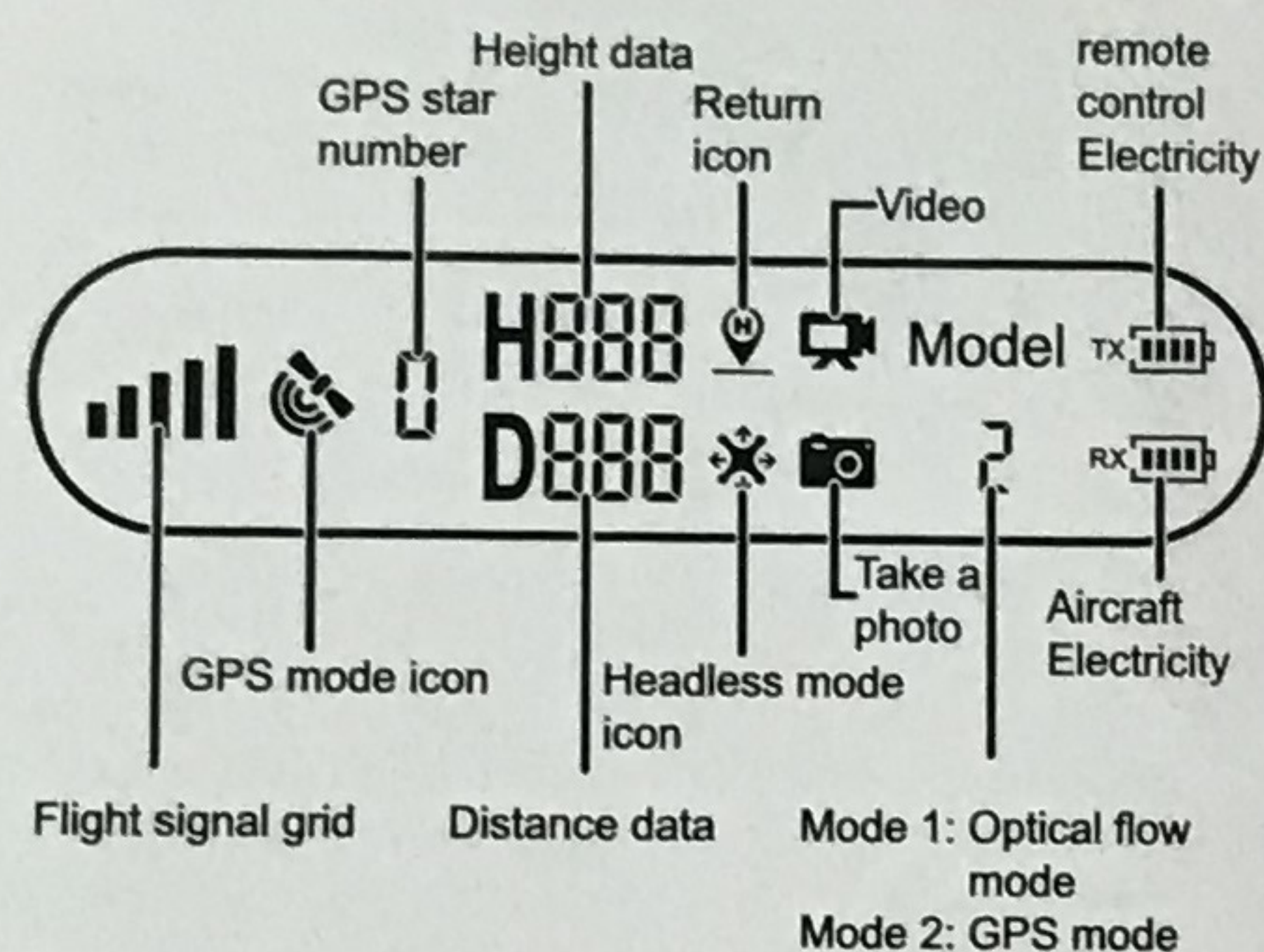

## Remote control battery installation

Open the remote control battery cover, insert the 4 AA batteries correctly according to the positive and negative poles indicated by the remote control, and then replace the battery cover.

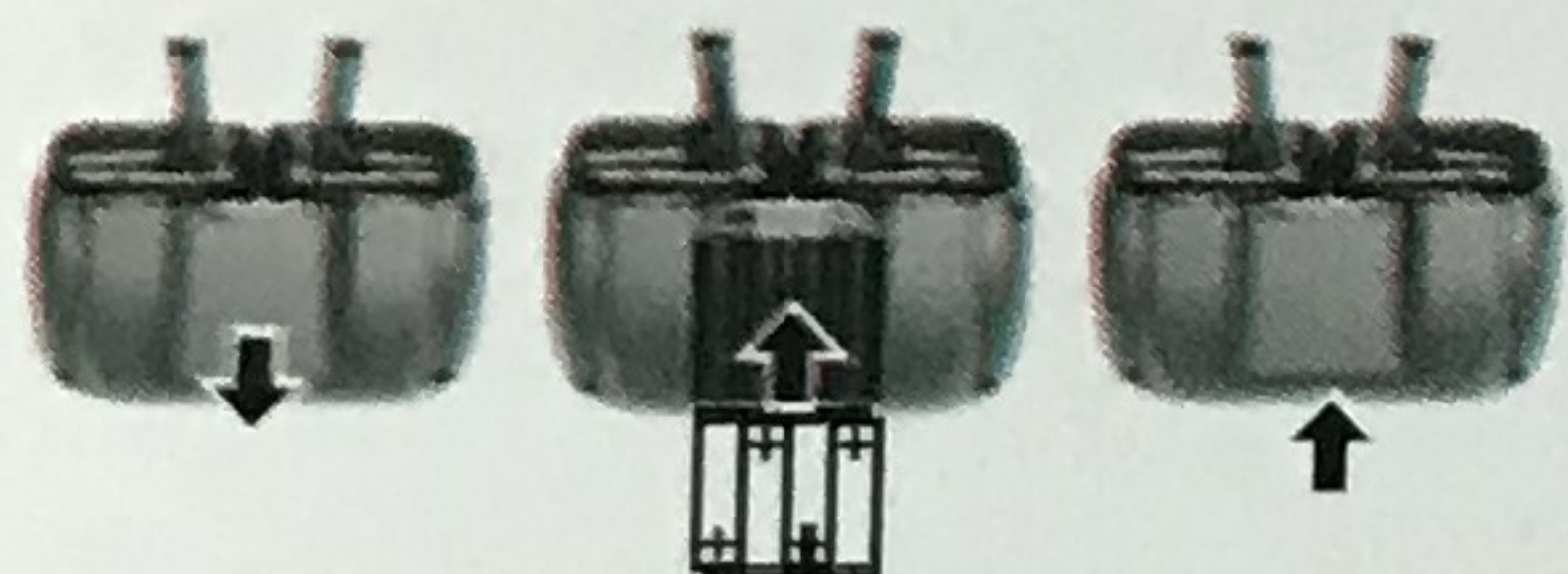

- ⚠ The remote control uses 4 "AA" non-rechargeable batteries or "AA" rechargeable batteries. (Sold separately)
- Pay attention to battery polarity when installing or replacing batteries.
- Non-rechargeable batteries are not rechargeable. Use only batteries that are the same or the same as the recommended batteries.
- Do not mix old and new or different types of batteries.
- Remove the exhausted batteries in time, and do not throw away used batteries.
- Take out the battery for a long time if not in use to avoid damage to the product caused by battery leakage.

## Pre-flight inspection

1. Are the batteries of the remote control and drone sufficient?
2. Whether the blades are installed correctly.
3. Whether the motor starts normally after booting.

## Drone pairing

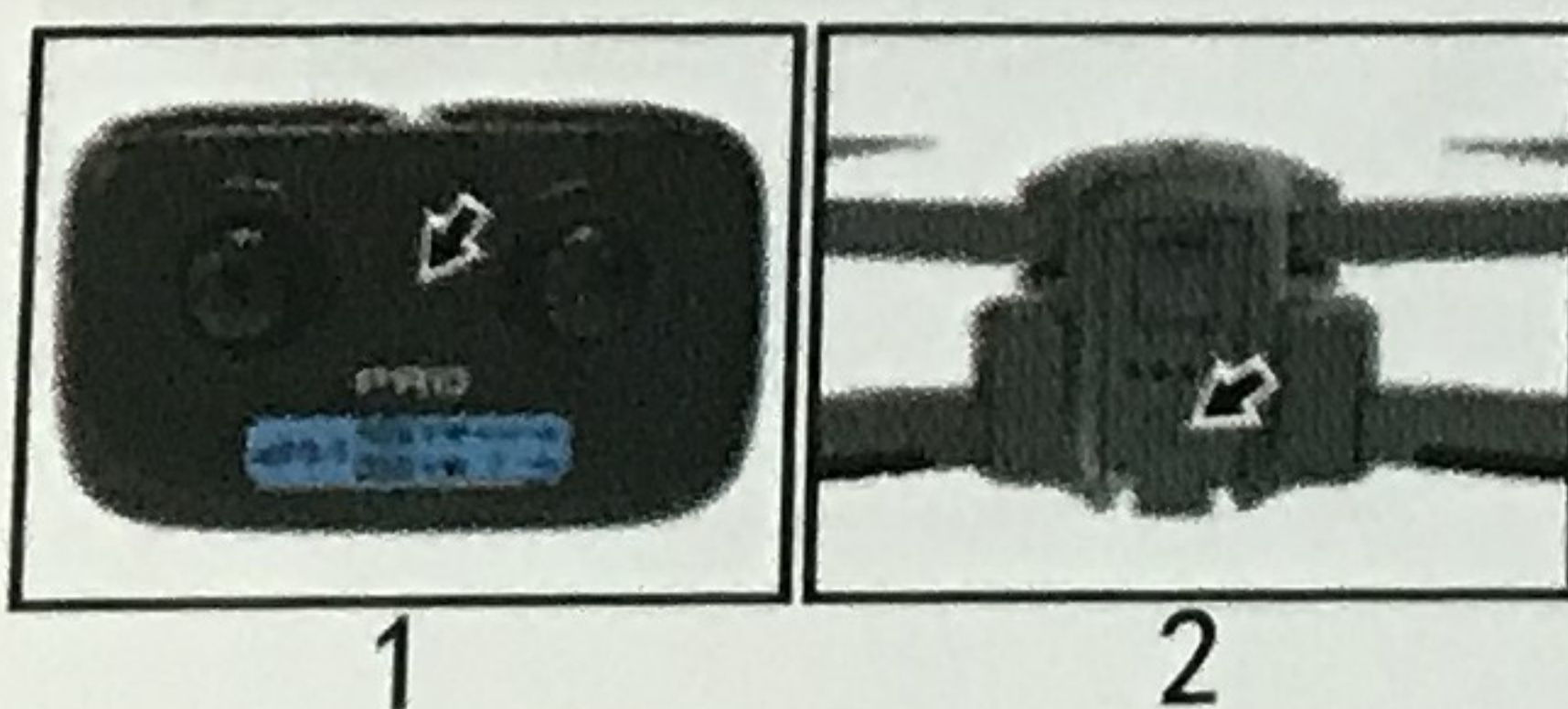

The remote control is turned on and the indicator light flashes. Press and hold the drone battery switch, the battery indicator lights up from left to right, the drone light flashes, the remote control indicator light changes from flashing to long light, and the code is successfully matched.

## Remote control dual mode

The default Mode2: GPS / optical flow dual mode when booting. When the Mode2 mode is enabled, it needs to be used outdoors in an open place without signal interference such as high-rise buildings and high-voltage wires.  
Mode1: Optical flow mode. When using this mode, you need to turn off the GPS function before taking off.  
[Cannot turn off Mode 2 (GPS mode) after GPS positioning]

## Geomagnetic correction function

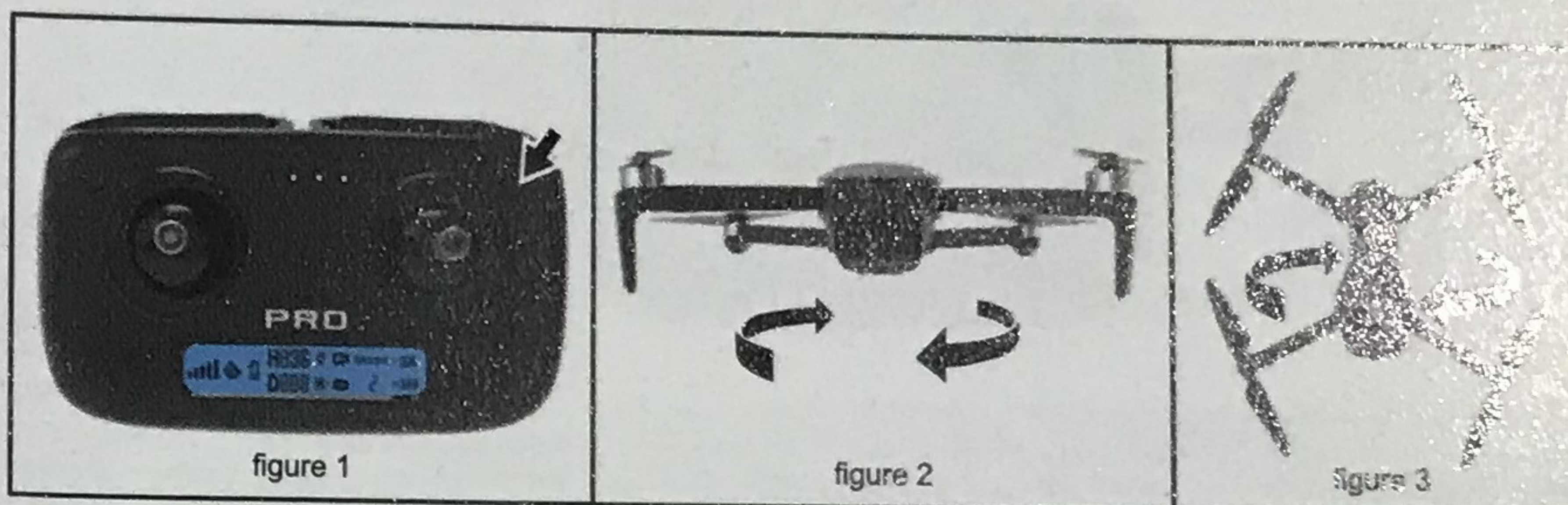

After the drone is successfully linked, press and hold the remote control camera button for about 5 seconds (Figure 1), the remote control will beep once, the drone light will flash quickly, pick up the drone 1 meter from the ground and turn it clockwise 3 (Figure 2), at this time, the remote control drops a beep and the drone is erected, the camera is facing downward (Figure 3), and the clockwise turn of the remote control drops the drone light once every 1 second. can.

Tips: Please make sure that the take-off environment is open, and the satellite signal is greater than 7 stars before take-off.

- Do not perform calibration in areas with strong magnetic fields, such as magnetic deposits, parking lots, construction areas with underground steel bars, etc.
- Do not carry ferromagnetic materials with you during calibration, such as keys and mobile phones.
- Do not calibrate near large pieces of metal.

## Drone gyroscope and gimbal level correction



Place the drone still on a horizontal surface, and press and hold the remote control for 5 seconds to make a beep. As shown in the figure, the drone light changes from fast flashing to slow flashing.

## Connect with APP (mobile phone needs to support 5G-WiFi signal function)

Turn on the mobile device to scan the QR code on the APP instruction manual and download the APP, then turn on the WIFI function of the mobile device, select "XL-PRO-4K-5G-\*\*\*" (serial number) in the WIFI list, and exit the interface. To open the app.

Note: At this time, the remote control is turned off, and the mobile phone app will connect to the drone in about 5 seconds to control the drone. If the drone is not coded with the remote control after it is turned on, after the drone is directly controlled by the mobile phone, the remote control cannot be coded with the drone.

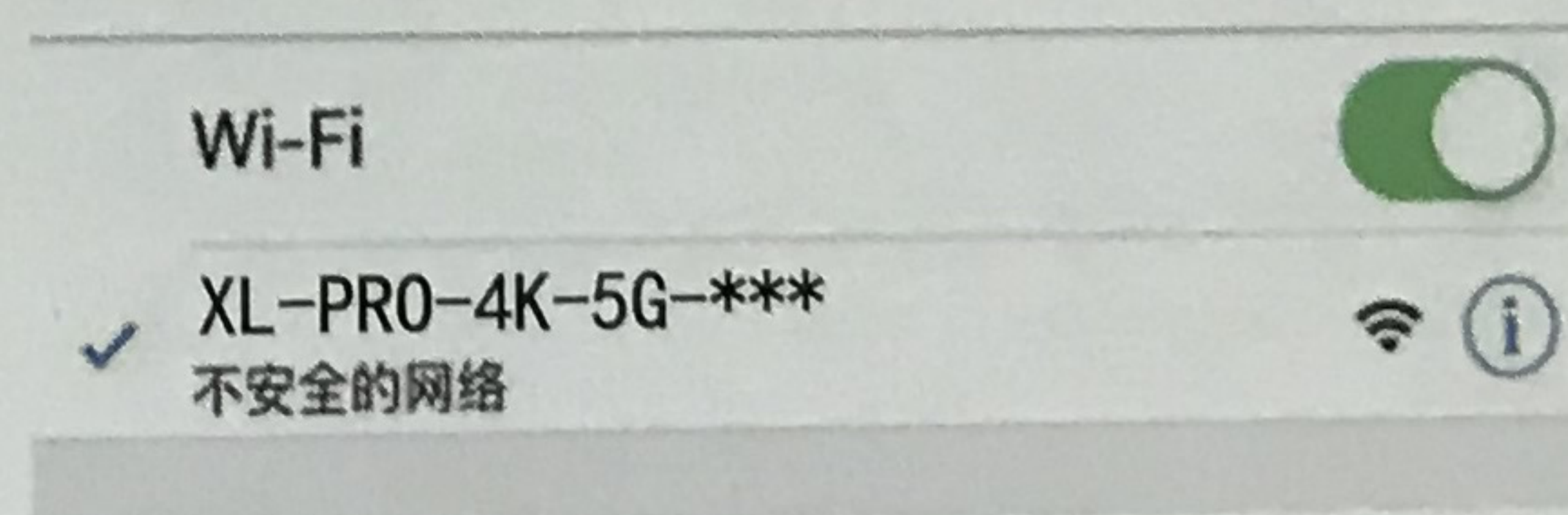

## Mode switch

1. Mode 1: [Optical flow mode] It is suitable for indoor open areas. After the drone and remote control are linked, the geomagnetism and gyroscope are corrected, the display on the remote control changes from Mode0 to Mode1, and the drone will automatically perform GPS search satellite positioning, automatic protection program will not be able to take off, you need to press and hold the video button for 5 seconds, the remote control emits a "dip", which means that the GPS can be unlocked after taking off. (Note: Mode1 optical flow mode does not have a series of GPS functions such as low-power return, one-click return, etc. Please pay attention to the flight distance and altitude when using)



2. Mode 2: [GPS / optical flow dual mode] It is suitable for outdoor open areas without signal interference. After the drone and remote control are linked, the geomagnetism and the gyroscope are corrected, the display on the remote control changes from Mode0 to Mode1. UAV automatically performs GPS satellite search and positioning (Drone search is placed in an open area, and there are no high-rise buildings or cars, high-voltage wires and other obstructions around it, otherwise the drone may not be able to complete the GPS satellite search and positioning), When the number of satellites reaches about 10, the positioning is completed, the remote control emits a "drop", the remote control display changes from Mode1 to Mode2 to indicate that the positioning is successful, and you can unlock the takeoff. (Note: Before GPS mode is completed, the drone will automatically take off the protection program and it will not take off)

## Drone unlock

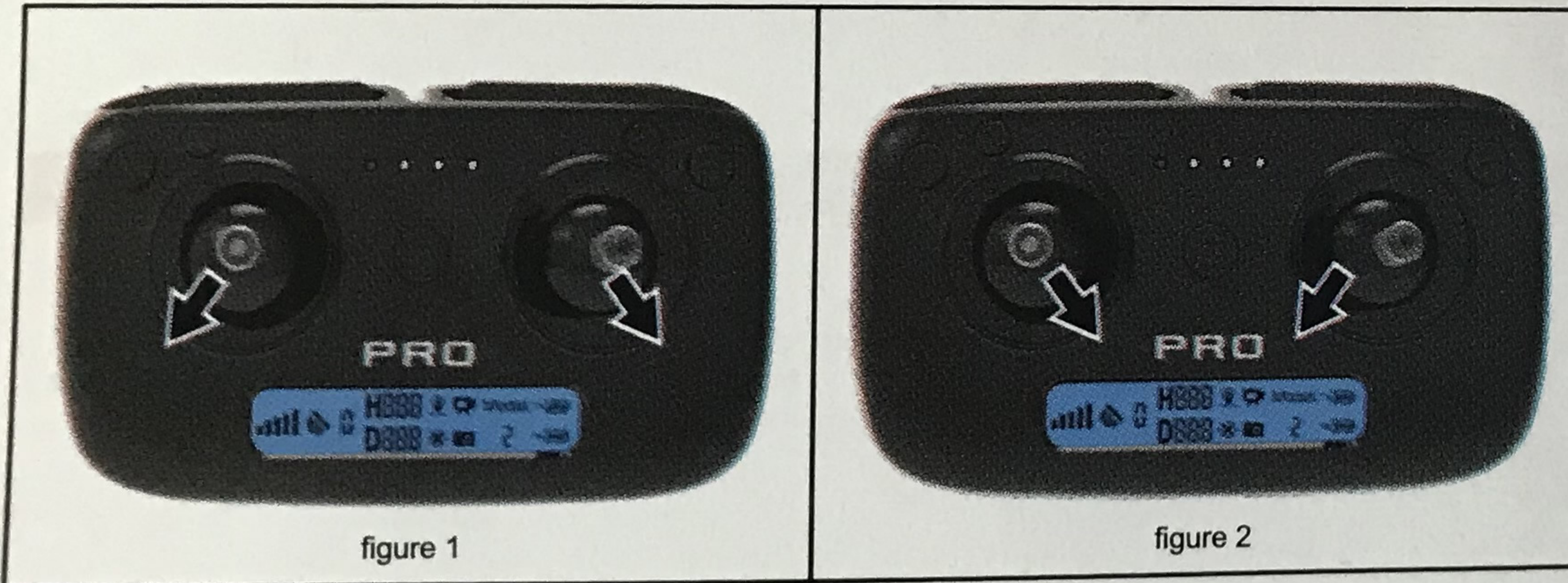

figure 1

figure 2

At this time, the throttle stick and the directional stick are pushed to the lower left corner and the lower right corner at the same time (Figure 1), or pushed to the lower right corner and the lower left corner (Figure 2) at the same time, the unlocking can be completed and the motor can fly after starting.

## Basic flight

### Basic flight steps

1. Code the remote control with the drone, and the drone completes the initialization.
2. Geomagnetic calibration. (Do not need to calibrate each time at the same location)
3. After the drone gyroscope is detected, unlock the drone.
4. Push the throttle stick up, the drone will take off, and the left / right joystick will control the attitude of the drone.
5. Turn off the power of the drone first, and then turn off the power switch of the remote control.

## Flight control method

Remote Control	Drone

### One-click takeoff / landing

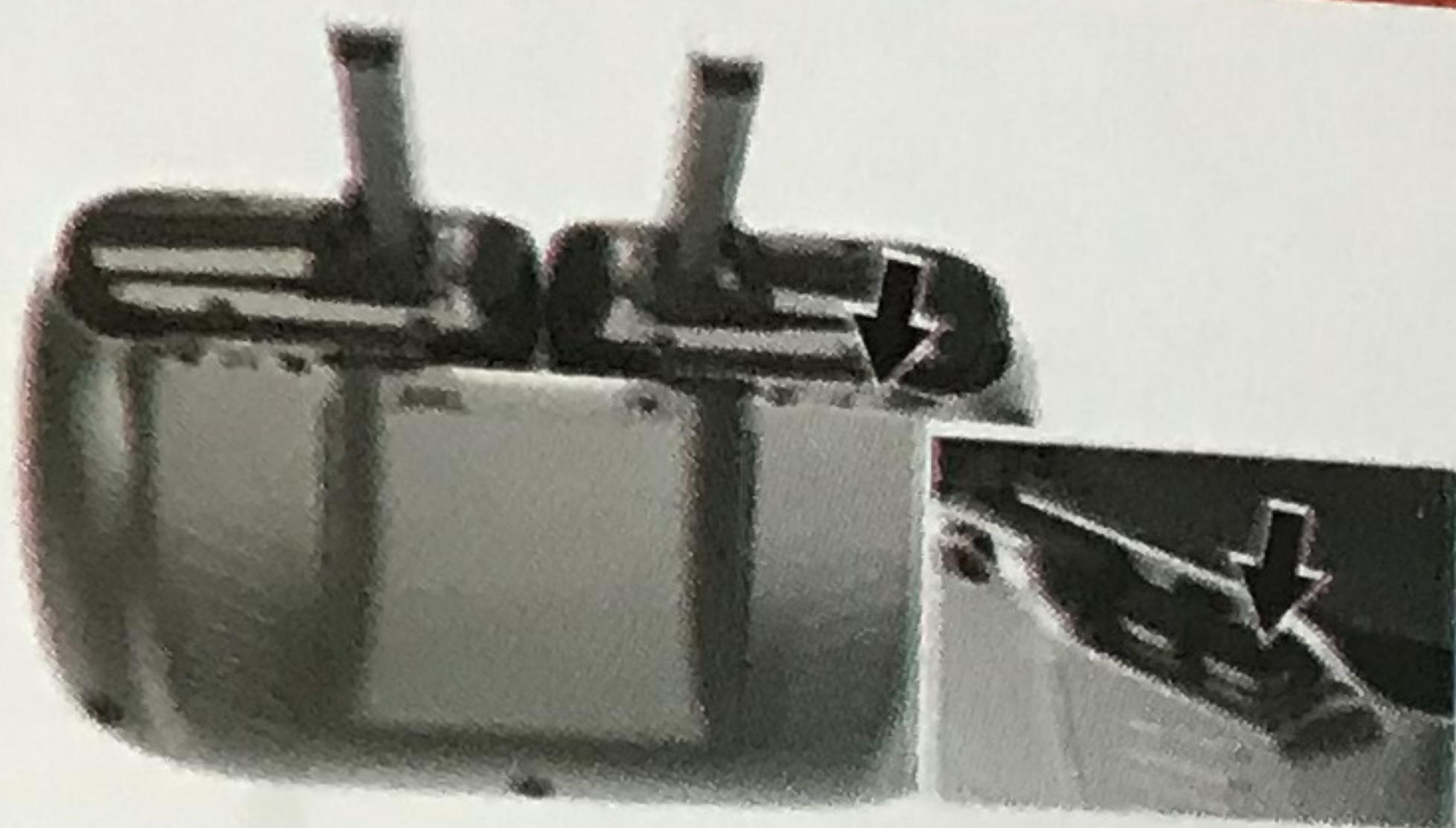

- After the drone is unlocked, press the one-button take-off button briefly, and the drone will automatically take off to hover at a height of about 1.5 meters.
- When the drone is in flight, press the one-button take-off button briefly, and the drone will automatically land on the ground.

### Headless mode

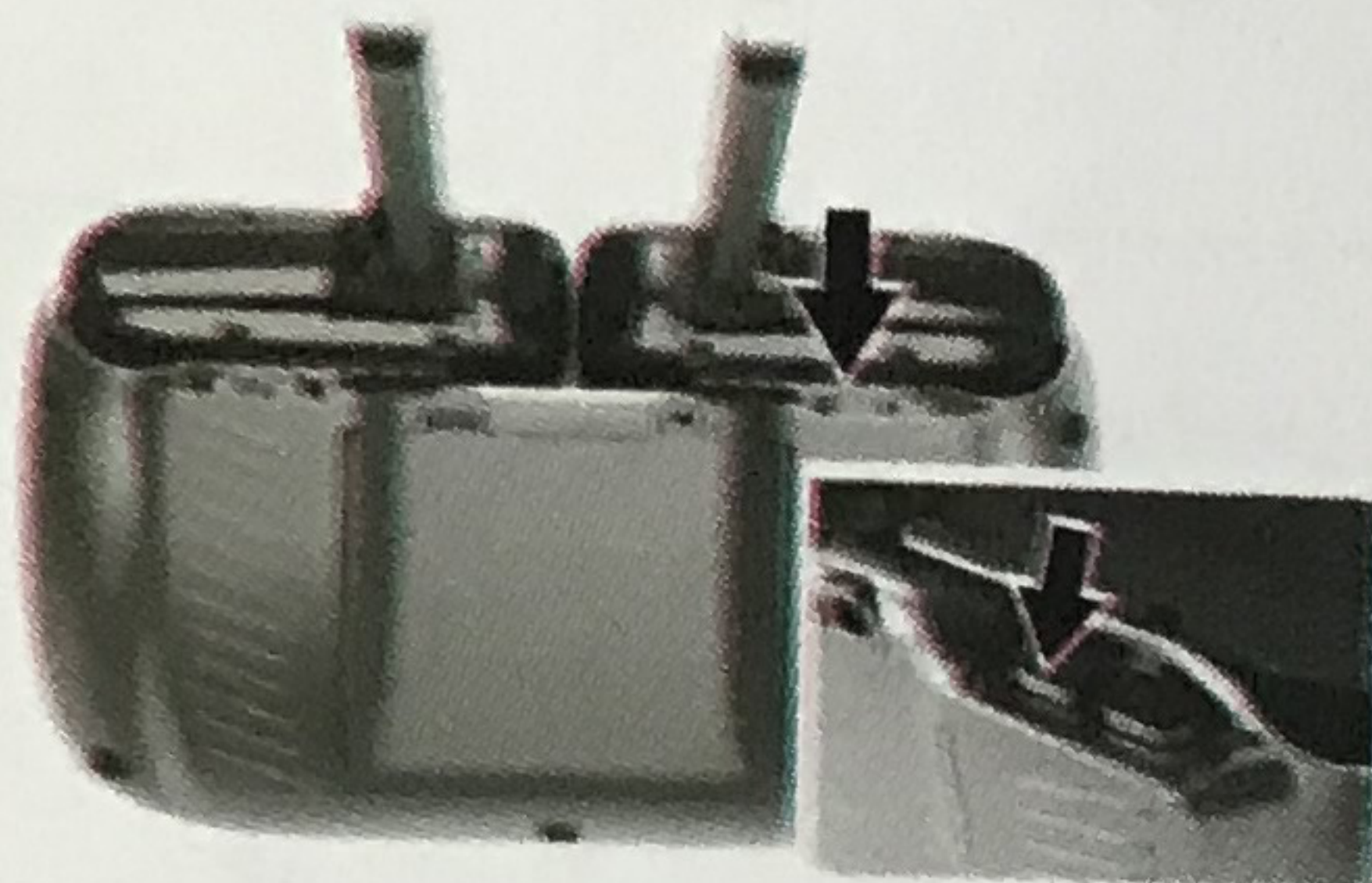

Press the headless mode button, the remote controller will make a "dipping" sound. When the drone is unlocked, the direction of the nose is directly in front of the flight. During the flight, rotate the remote in the direction to direct the flight. When the drone is unlocked, the direction the nose points.

#### Home Return (Not available in Mode 1 optical flow mode)

The drone has a home function. If the home point is successfully recorded before takeoff, the communication signal between the remote control and the drone is lost or the home key is pressed, the drone will automatically return to the home point and land to prevent accidents.

- There are three different ways for drones to return home:
1. One-click return
  2. Uncontrolled return
  3. Low battery return.

**⚠ Note for return flight:**

- During auto return, the drone cannot avoid obstacles.
- When GPS signal is not good or GPS is not working, you cannot return to home.

Home Point: When taking off or during flight, when GPS receives 7 or more stars for the first time, it will record the current position of the drone as the home point.

### One-click return



When the GPS signal is good (the number of satellites is greater than 7), you can start the drone home by pressing the one-way home button on the remote control. The home process is the same as the uncontrolled home. Use the stick to control the drone to avoid obstacles. Press the home button again to exit home, and the user can regain control.

### Runaway Return

The GPS signal is good (the number of GPS satellites is greater than 7), the compass is working normally, and after the drone successfully records the home point, if the remote control signal is continuously interrupted for more than 6 seconds, the flight control system will take over the drone control and control the drone fly back to where there was a signal and stop.

### Low battery return

After the drone is low-voltage, the indicator light will flash slowly. At this time, the drone will automatically return to the vicinity of the takeoff point 20 meters. (After the low-power drone returns to the vicinity of the take-off point, the height and distance of the drone will be limited to 20 meters)

**⚠ Reminder:** The drone is in the low-power return mode, and the remote control cannot cancel the return mode.

### Photo / Video

Press the remote control "📷" button to take a picture, the remote control LED screen display icon "📷" flashes, press the remote control "📹" button to record, the remote control LED screen display icon "📹" has been slow flashing, then press the "📹" button to exit the recording.

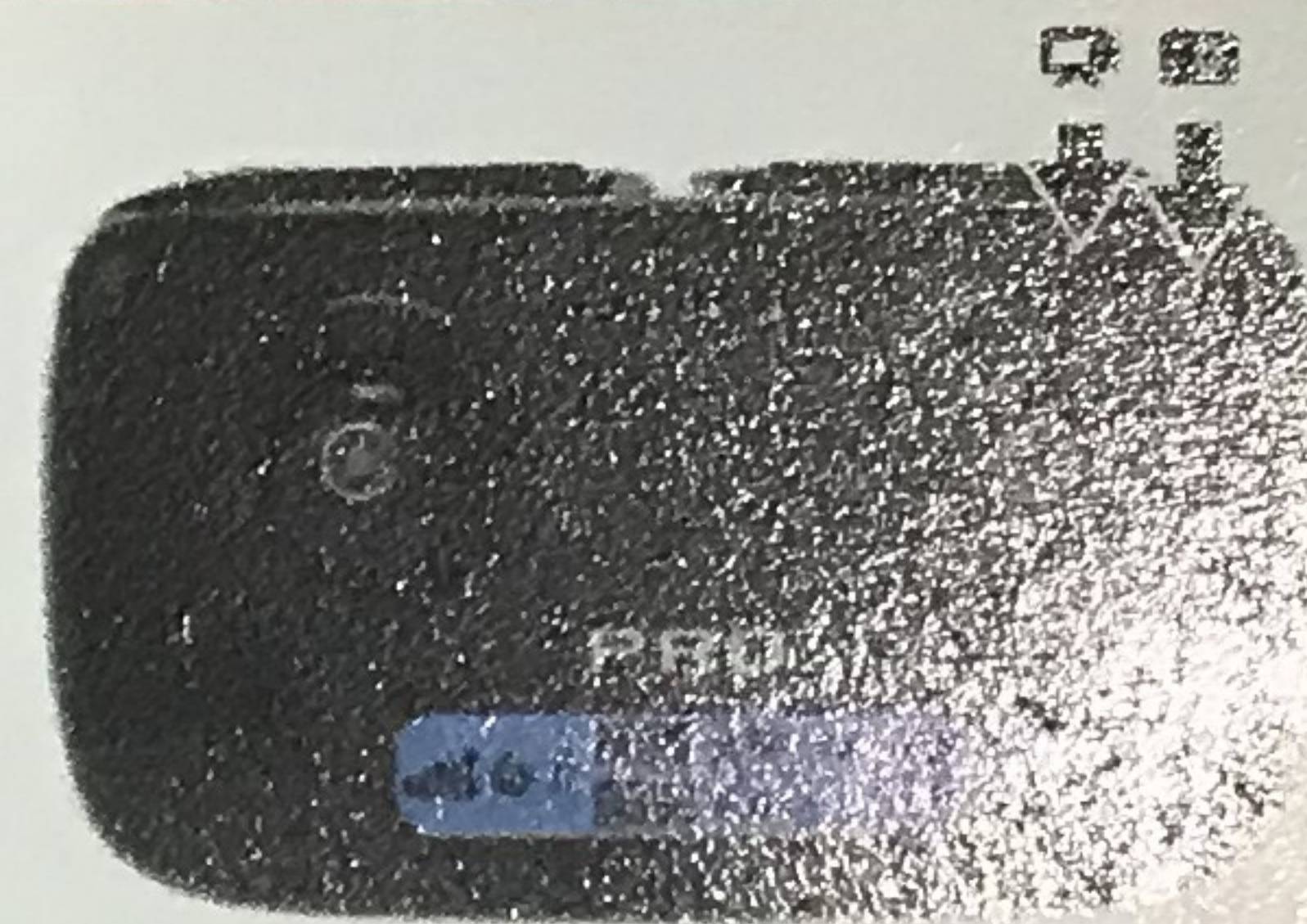

### Received signal strength indication

The icon "📶" is the received signal strength indication. The more the number of segments is displayed, the stronger the signal is, and the weaker the signal is.

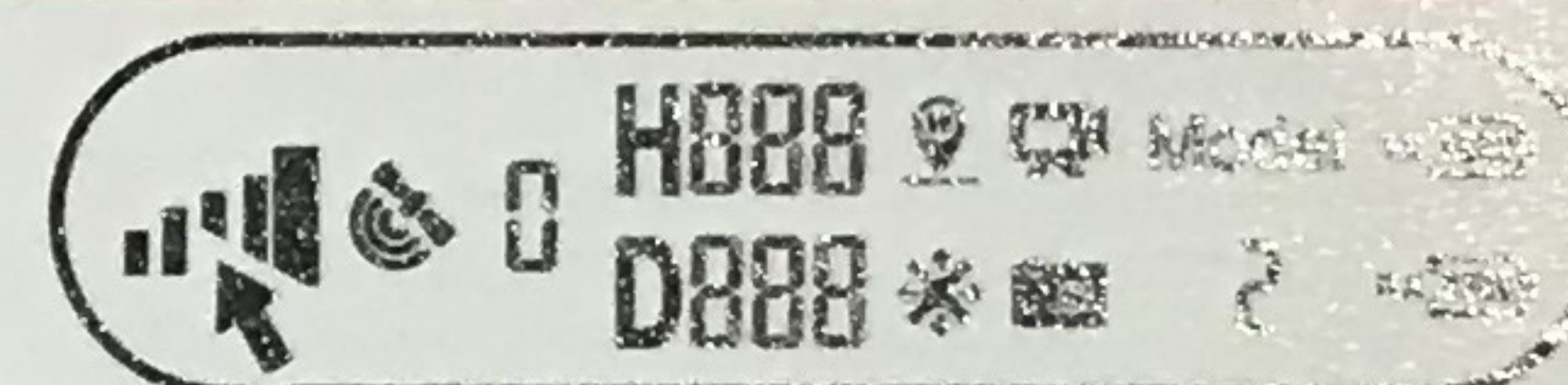

### 5G WIFI Channel Switching Guide

This product uses WIFI with 5G frequency, works on 36 or 149 channels, and the factory defaults to 36 channels. The list of available channels in the corresponding countries is as follows:

channel	frequency (MHZ)	USA	Europe	Japan	Singapore	China	Taiwan	Korea
36	5180	Available	Available	Available	Available	Available	Available	Available
149	5745	Available	Disable	Disable	Available	Available	Available	Available

### Product parts

#### Basic parts

Front rocker A	Front rocker B	Rear swing arm A	Rear swing arm B	camera

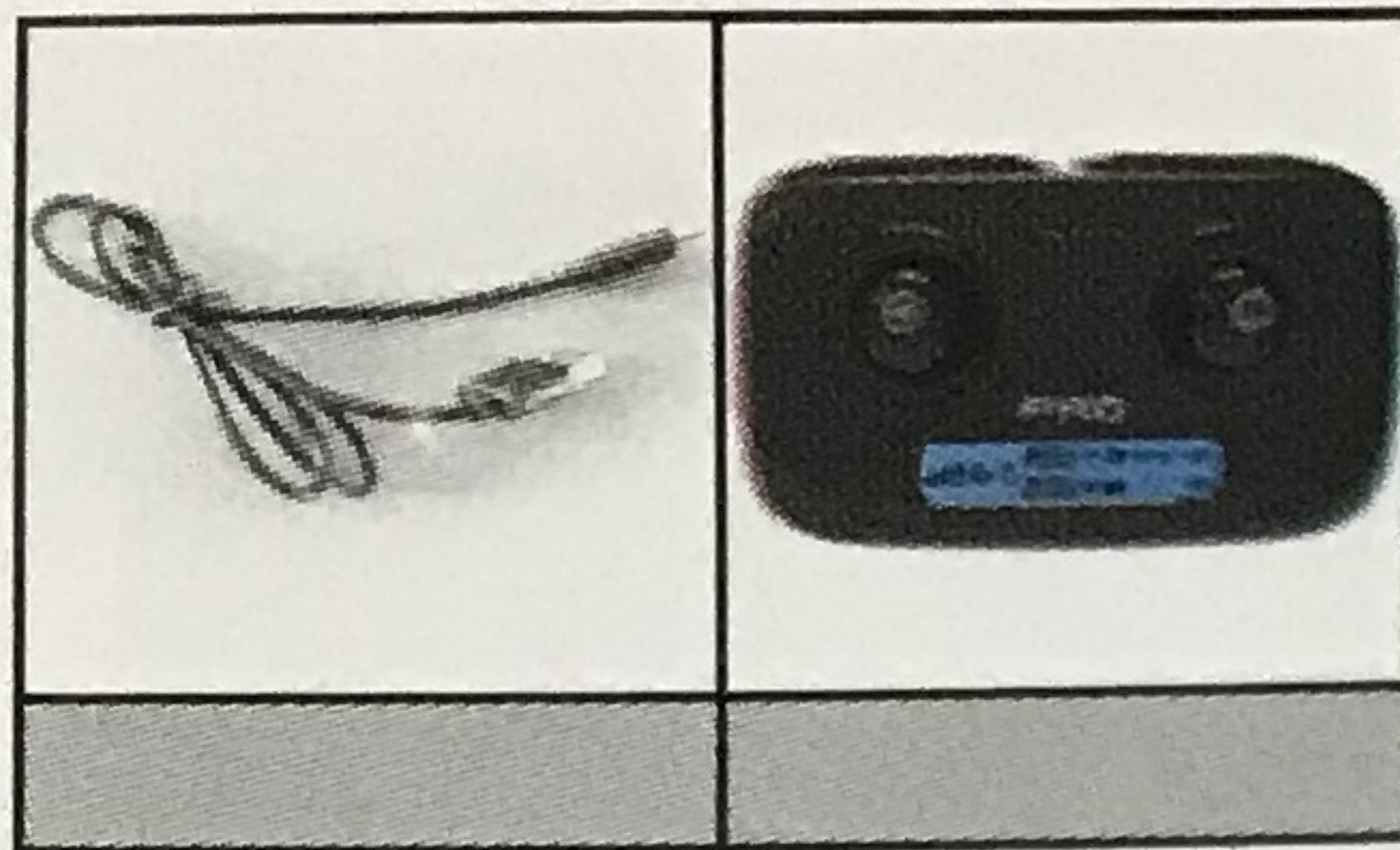

### Don't panic if you encounter problems

No.	problem	Solution
1	Mode 1 The drone motor can rotate, the aircraft cannot take off, the lights flash quickly and slowly	Without turning off GPS, drone enables protection
2	After the GPS function is turned off in Mode 1, the drone motor can rotate and the drone cannot take off. The lights flash quickly and slowly	Recalibrate the geomagnetism after restart
3	After take-off in Mode 1, the drone keeps blinking and cannot hover.	The ground is too smooth and the environment is too dark, which will cause the optical flow lens to be unstable. Please get a good light and fly in a place where there is no reflection on the ground.
4	After taking off in Mode 2, the drone keeps blinking and cannot hover. It floats around. The remote control always switches between Mode 1 and Mode 2.	GPS positioning is not good, interference is too big, please get open, unobstructed, no high voltage wires
5	Mode 2 The drone motor can rotate, the aircraft cannot take off, the lights flash quickly and slowly	Recalibrate the geomagnetism after restart
6	Drone shakes a lot	The blade is deformed or damaged, it needs to be replaced
7	When the picture is tilted during aerial photography	Land the drone to a flat ground and perform the gimbal level correction again.

## Software instruction manual

### Software installation instructions

#### 1. Install the mobile client

Please scan the QR code below to download the mobile app to the corresponding website.



IOS



Android (CHN)



Android (google)

#### 2. Connect Drone WiFi

1. Power on the drone;
2. Find the drone hotspot in the phone "Settings-WLAN";
3. Click the hotspot network (no password), and the phone will connect automatically.

A. For users using SG906 PRO, please click WLAN in the settings of the mobile phone, as shown in the figure below, select the "XL-PRO-4K-5G-\*\*\* (serial number)" network and connect, then open the mobile phone APP to use.



Wi-Fi

✓ XL-PRO-4K-5G-\*\*\*



B. Users using SG906 MAX, in the mobile phone settings, click on the wireless LAN, as shown below, the mobile phone will be able to search the WIFI signal "XL-MAX-5G-\*\*\* (serial number)" sent by the remote control to increase the distance map And the WIFI signal "XL-PRO-5G-\*\*\* (serial number)" is transmitted from the camera 's camera to show the normal distance image. When using the remote control, it is recommended to select "XL-MAX-5G-\*\*\* (serial number)" Network and connection, and then open the mobile APP to use. (Optional)



Wi-Fi

✓ XL-MAX-4K-5G-\*\*\*

XL-PRO-4K-5G-\*\*\*

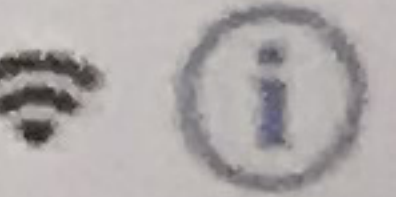

#### 3. Recommended model configuration

	Configuration	Recommended	Optimal (Support 2 k)
(1) ios	Product model	iPhone 6 and above	iPhone 6 and above
	System version	iOS 8.0 and above	iOS 9.0 and above

#### (2) Android

	Configuration	Recommended	Optimal(Support 2 k)
	The CPU model	Snapdragon 630 and above Samsung Exynos 7420 and above Hair division Helio X25 and above Kirin 950 and above	Snapdragon 835 and above Samsung Exynos 8895 and above Hair division Helio X30 and above Kirin 970 and above
	System version	Android 5.0 and above	Android 8.0 and above
	Memory size	3Gand above	6Gand above
	CPU usage	Occupancy rate of 25% and below	Occupancy rate of 10% and below

Clean up the background program, which can effectively reduce the CPU usage.

**APP function introduction:** When the drone is in the following environment, the fixed hover effect is not good.

Note: A drone, at the same time, only one mobile app is allowed to connect!

Note: When the drone is in the following environment, the fixed flow hovering effect of the lower lens is not good, which will make it difficult for the drone to fly smoothly and the camera will shake.

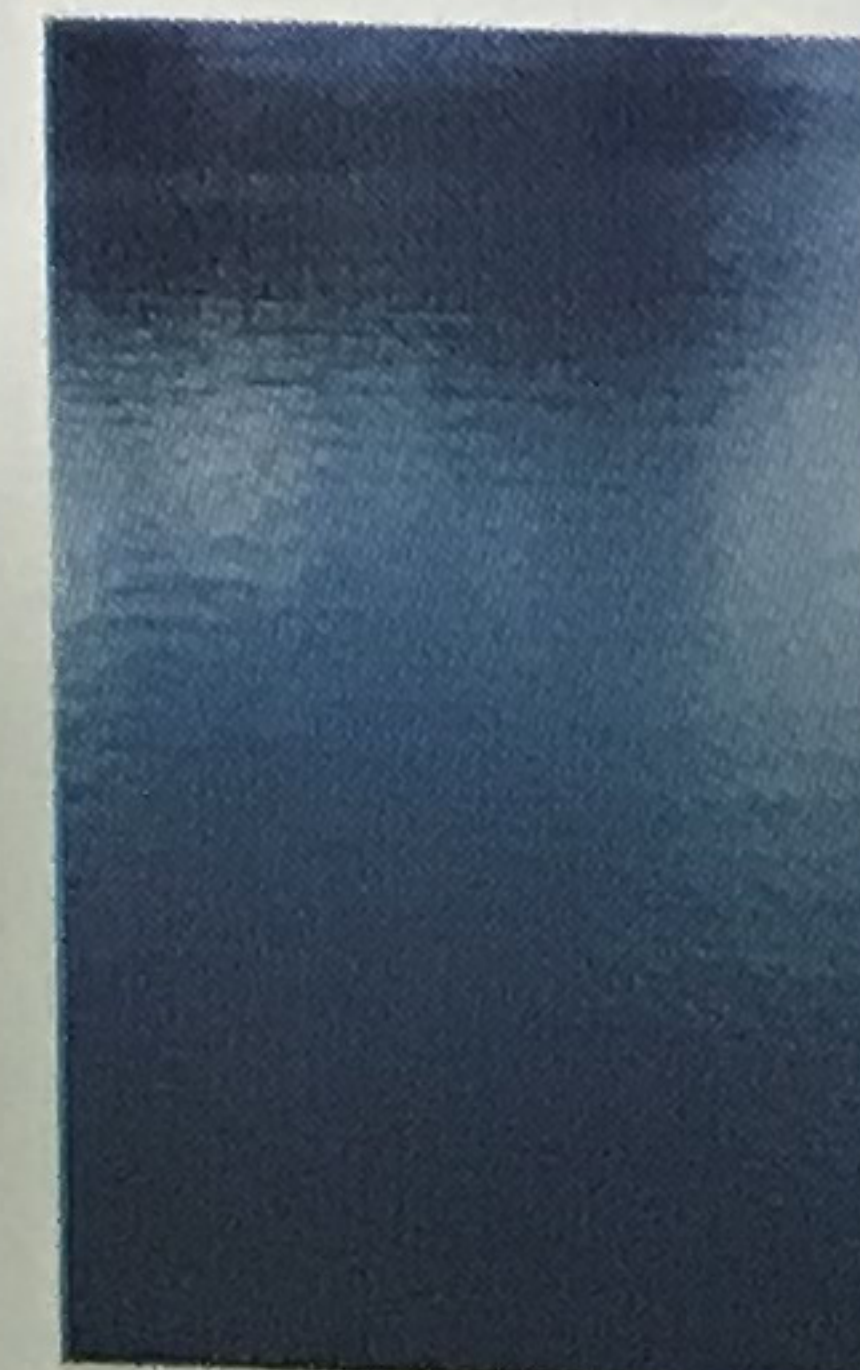

The surface of

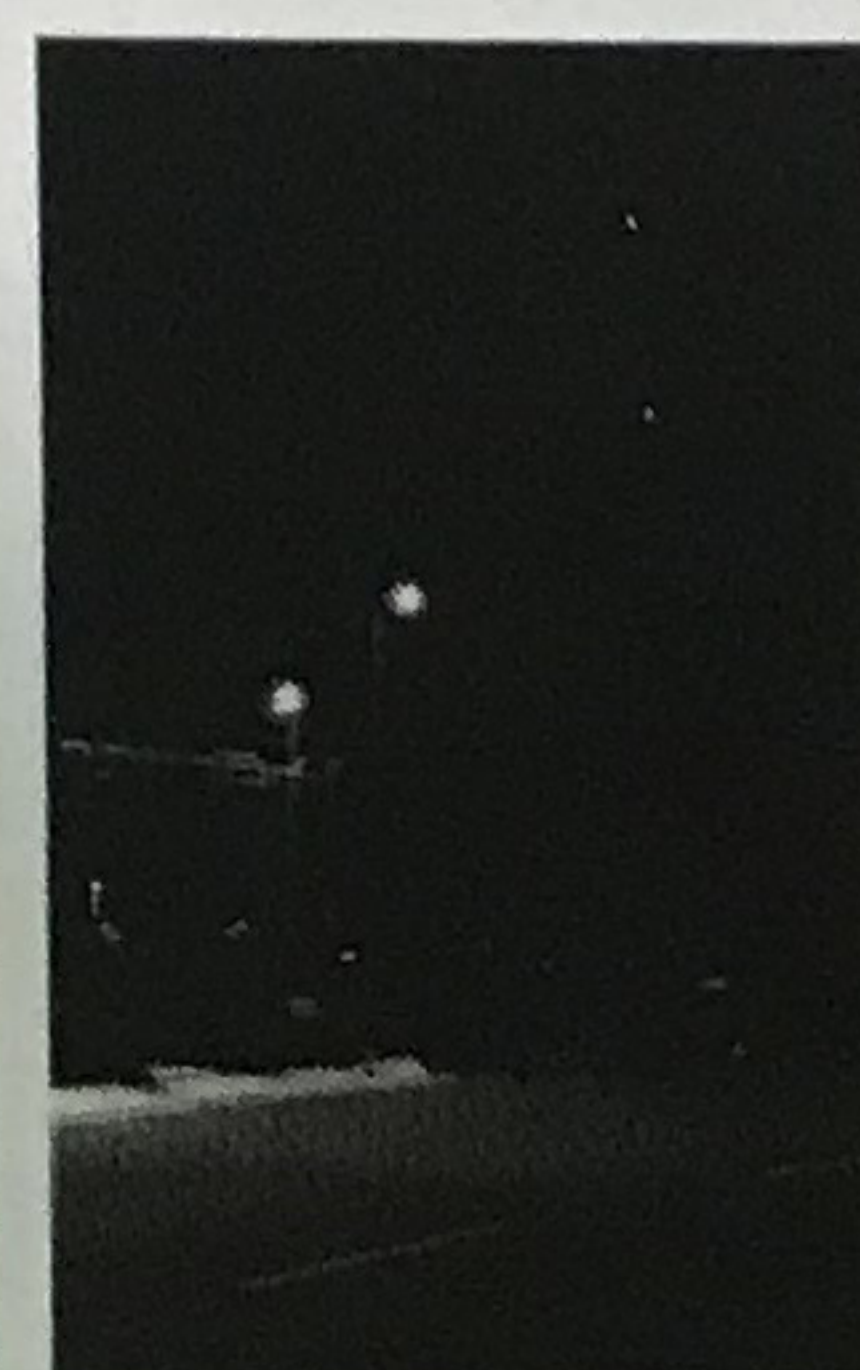

Dimly lit



Large vertical



Smooth reflective

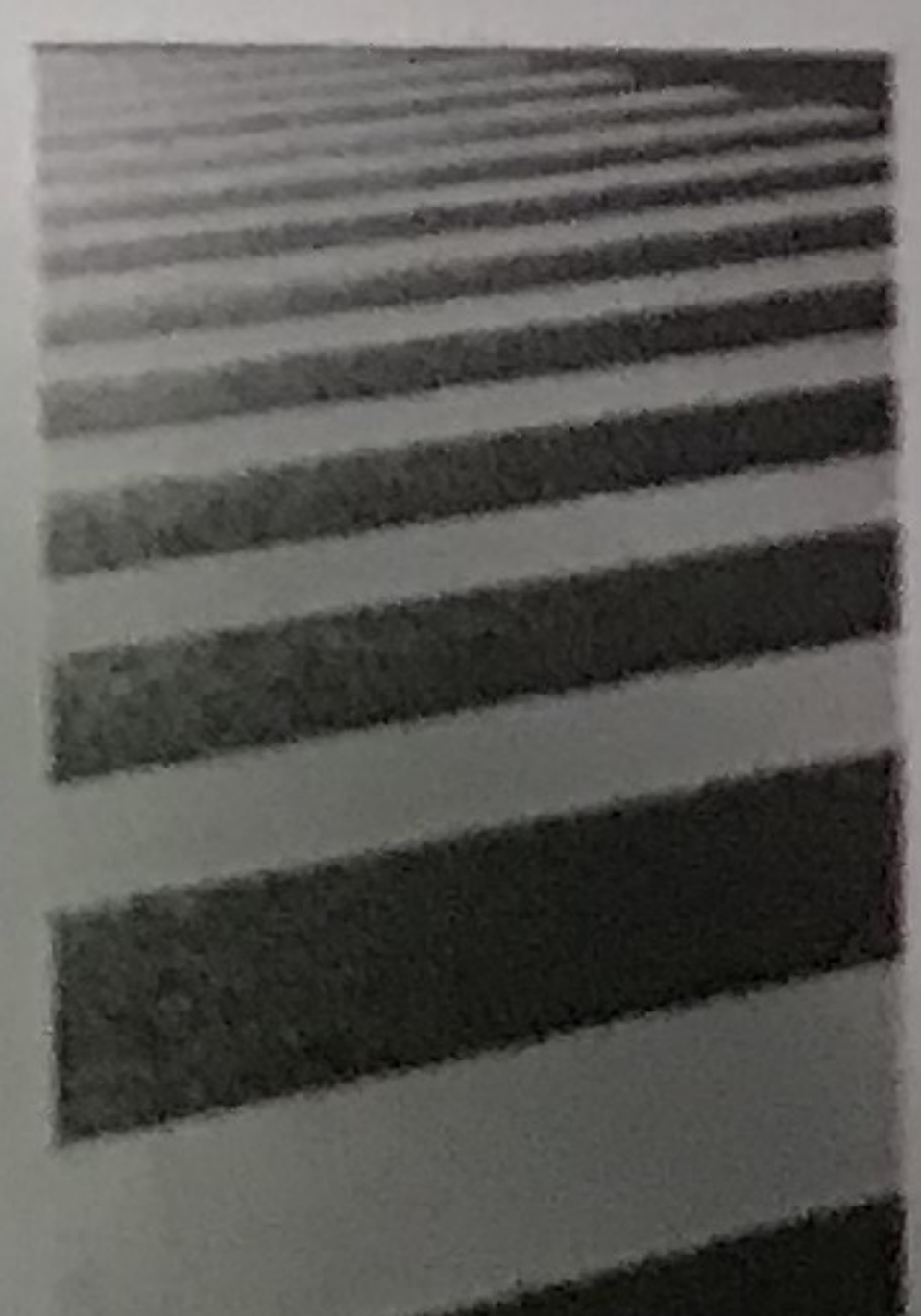

Two color stripes

## 1.1 Introduction to the Operation Interface

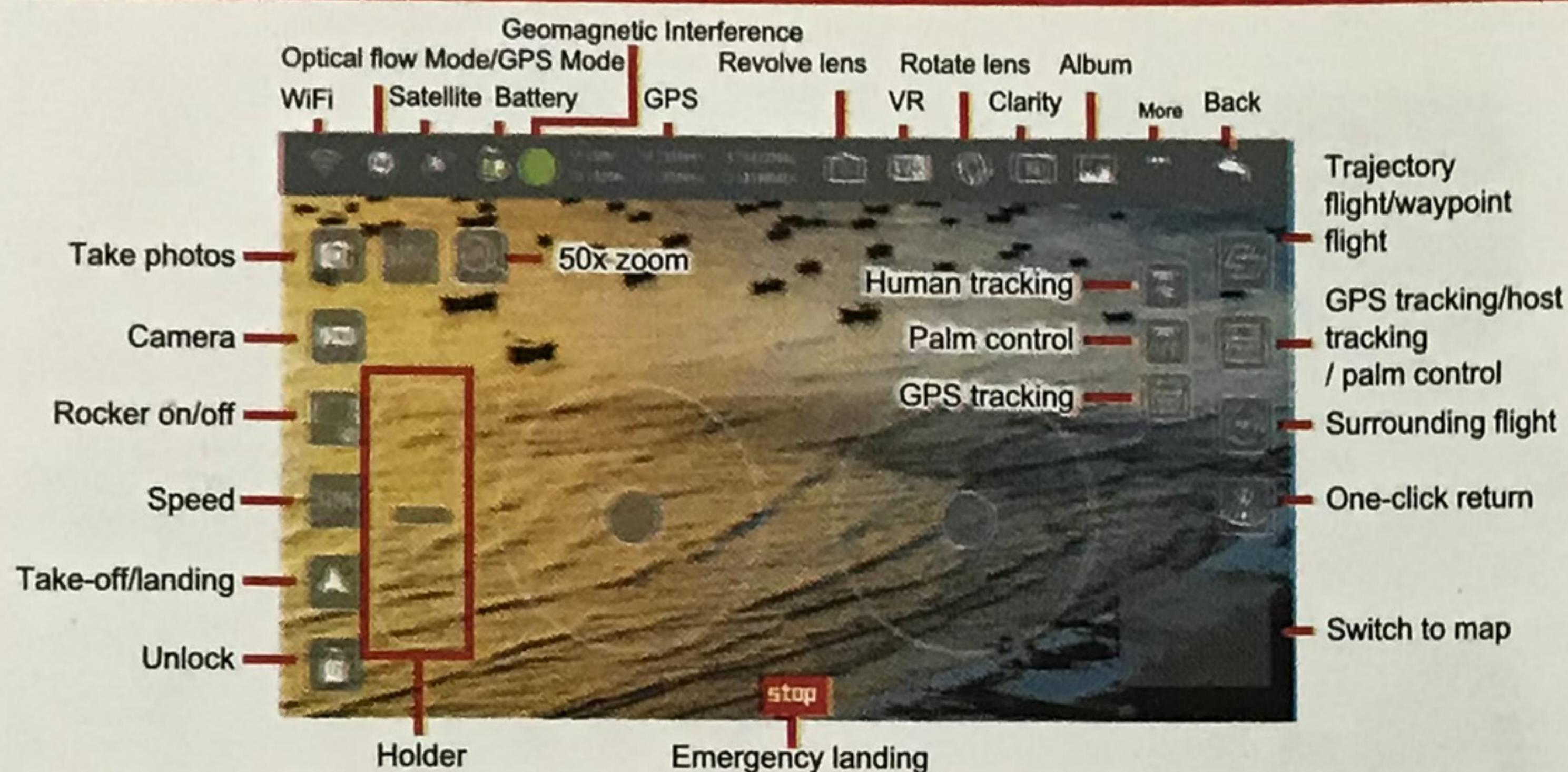

### 1.2.1 Function Description

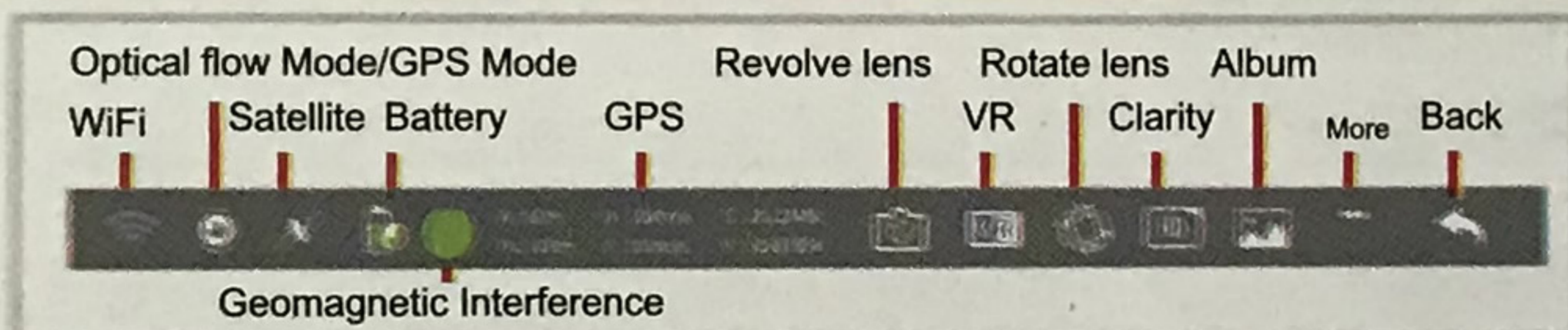

- WiFi:** Display chart signal strength;
- Satellite signals:** Represents current flight mode and number of satellites; Scintillation means that the current mode is the optical flow point, without the function of returning, following, circling and pointing. Constant light indicates current GPS mode.
- Battery:** The battery status of the aircraft.
- (1) 2-4 grid indicates the normal power, which can operate the returning, following, circling and pointing flight functions normally in the GPS mode.
- (2) 1 grid (flicker state) represents the current low power state, and the aircraft will perform the automatic course reversal function. There is no following, circling and pointing flight function in low power state.
- GPS information:** Displays the height, distance and corresponding longitude and latitude of the current aircraft from the reentry point.
- Geomagnetic interference:** Green indicates normal; yellow indicates geomagnetic interference; orange indicates strong geomagnetic interference; red indicates strong geomagnetic interference. When the orange or red icon is displayed, leave the current interference position and recalibrate.
- Revolve lens:** Can switch between front lens and down lens.
- VR model:** Click into VR mode.
- Rotate lens:** Record the relevant parameters of each flight.
- Clarity:** Click to switch the video definition.
- Album:** Photos and videos can be viewed.

### 1.2.2 Function Description

- Take photos:** Click the button to take photos according to the current lens (front lens or down lens).
- Camera:** Click the button to shoot videos according to the current lens (front lens or down lens).
- Rocker on/off:** Click to switch to mobile phone control or remote control.
- Speed:** Displays the current state of fast and slow. Click to switch to fast and slow in mobile control mode.
- Take-off/landing:** After unlocking, one key can be used to take off or drop.
- Unlock:** After the calibration is completed, place the aircraft horizontally and click the unlock button to start the flight operation.

## 1.2.3 Function Description

- Trajectory flight/waypoint flight:** Waypoint flight: In GPS mode, the aircraft will fly according to the location selected on the map. Trajectory flight: In optical flow mode, the aircraft will fly according to the selected position.
- Human tracking:** Click the button in the optical flow mode, the aircraft will follow the target person flight. (See the next page for details)
- Palm control:** Click the button in the optical flow mode, the aircraft will follow the palm up and down. (See the next page for details)
- GPS tracking:** In GPS mode, click this button and the aircraft will follow the flight.
- Surrounding flight:** In GPS mode, the aircraft nose will fly around clockwise or counterclockwise with the current position of the aircraft as the center. During the surround process, you can control the rise, fall, forward, and reverse to adjust.
- One-click return:** In GPS mode, click to achieve one-click return.

### \* Other Instructions

- #### Human Tracking

  - Blue candidate boxes for the target person appears on the screen.
  - On the screen, tap your finger to select the target character.
  - After the target person is locked, the blue box will turn red. Make sure the red box target character is in the middle of the screen.
  - The tracking flight starts when the aircraft is about 2m away from the target figure. If the target character is lost, you need to click the target character again.

When the red frame is more than 80% of the human area, the best effect can be achieved.

#### Palm Control

  - facing the camera of the aircraft, lift it horizontally with one hand;
  - when the palm is framed by the red square on the App, gently move the palm;
  - at this point, the aircraft will follow the palm upward and downward flight;

When the distance between the palm and the camera is about 1m, can obtain the best experience.

### 1.2.4 Function Description

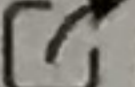
- Holder:** After the aircraft takes off, the holder will be displayed on the left side of the screen. At this time, if you move the slider upward, the front lens of the aircraft will move upward by a certain angle; if you move the slider down, the front lens of the aircraft will move downward by a certain angle.
- Rocker:** The left rocker can control the upward, downward movement, left and right turn of the aircraft, and the right rocker can control the forward, backward movement of the aircraft, and it can also move the aircraft towards the left and right.
- share:** After clicking  in the upper left corner of the screen on the control page, enter the album interface. When you click to view a photo or video, users can share photos or videos to major social platforms through  in the top right corner.

### 1.3 Gesture Recognition

Facing the front lens of the camera, the following gestures can be triggered to trigger the automatic camera or camera function of the aircraft:

 **Take Photos by Yeah Gestures** About 2m in front of the camera of the aircraft, hold the Yeah gesture with one hand flat. After the aircraft successfully recognized the gesture, the countdown of 3 seconds began to take photos;

 **Shoot Videos by Box Gestures** About 2 meters in front of the camera of the aircraft, put your hands on the position of the face jaw to make a square video gesture. After the aircraft has successfully recognized the gesture, the video will start. When the gesture is recognized again, end the recording (the time difference between two recognition should be more than 3 seconds);

 **Shoot Videos by Palm Gestures** About 2 meters in front of the aircraft lens, with five fingers and one hand flat; After the aircraft has successfully recognized the gesture, the video will start. When the gesture is recognized again, end the recording (the time difference between two recognition should be more than 3 seconds);

#### \* Special Instructions

To ensure that the lens gets a higher recognition rate :

1. Please aim the lens face to face;
2. Please fly in a good light environment;
3. Please conduct gesture recognition operation at a distance of about 2m from the lens.

In the following cases, it will result in a low lens recognition rate :

1. Weak light or backlight;
2. The WiFi signal is weak or the signal is disturbed.

### 2 MV Interface

After clicking the  button in the upper left corner of the screen on the control page, enter the MV interface. In the MV interface, you can shoot music videos.

#### Rotating picture

Click this button to enable the Rotate Screen feature. At this point, the finger swipes on the screen to rotate the image; if the finger double-clicks anywhere on the screen, the image can be magnified in an instant (this feature also applies when recording video).

Filter    Operating lever

Photo album

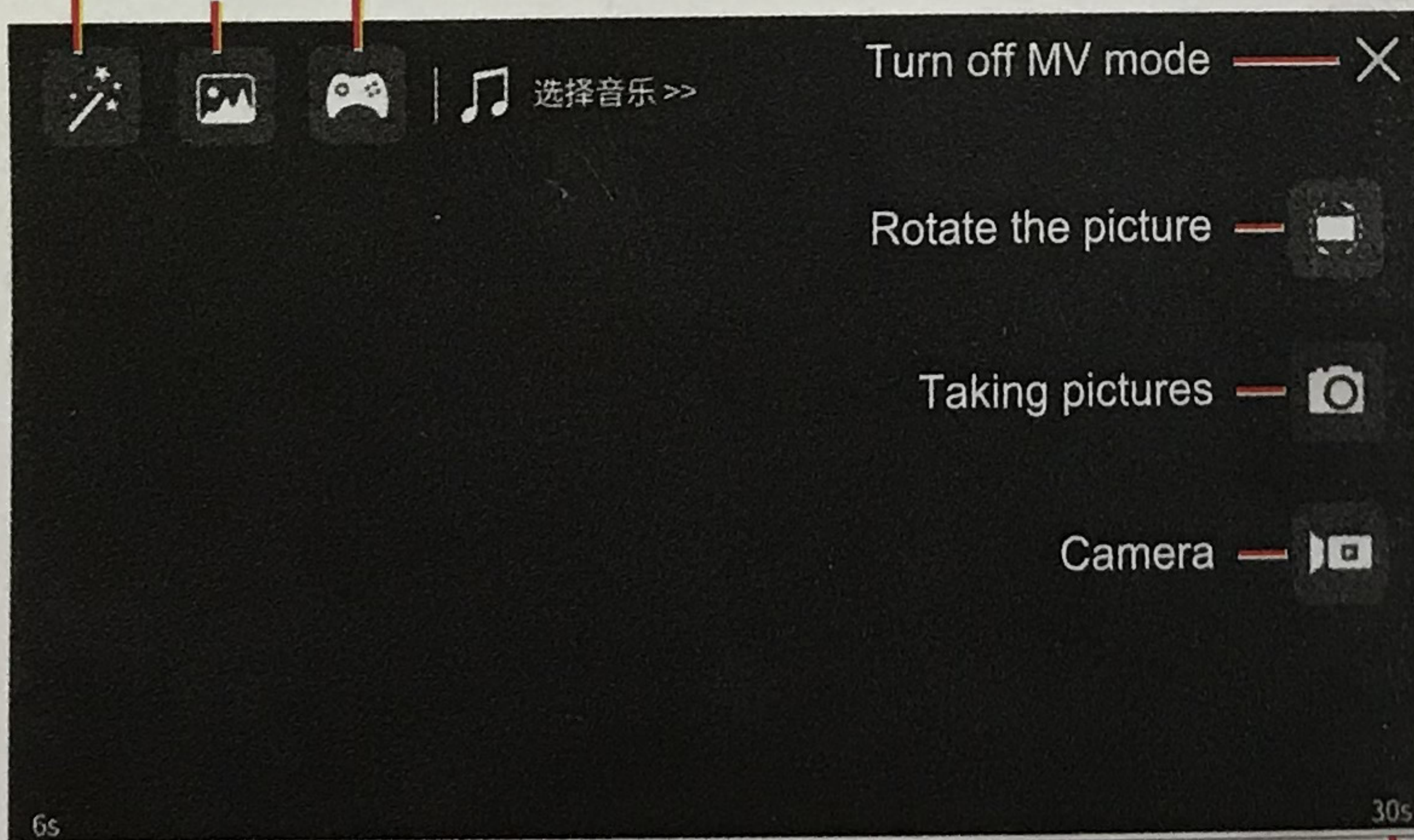

Length of recorded time

Recording progress bar

Length of music time



Zhongli Technology

